

Herring Cove Development  
Herring Cove Road  
Excavation & Construction

Prepared by Geoff MacLean, P.Eng.

Job No. 37051

CONSTRUCTION MANAGEMENT PLAN

REVISION #	DATE	DESCRIPTION
1	OCT 2023	REVISED AS PER COMMENTS
0	JUL 2023	ISSUED FOR REVIEW



36 Oland Crescent  
Bayers Lake Business Park  
Halifax, Nova Scotia B3S 1C6  
www.sdmm.ca

t: 902-455-1537  
f: 902-455-8479  
c: 902-789-6374  
e: gmaclea@sdmm.ca

## Revisions Summary

Revision 1 – Sections 1.1, 2.1, 2.2, & 7.2, Appendixes A, B, C, D, G & P

## Table of Contents

---

Section 1: Introduction .....	1
1.1: Project Description and Objectives .....	1
1.2: Project Contact Information .....	2
Section 2: Project Schedule and Logistics .....	2
2.1: Schedule .....	2
2.2: Key Dates .....	2
2.3: Hours of Work.....	2
Section 3 – Relevant Regulations & Guidelines .....	3
3.1: Occupational Health & Safety Regulations.....	3
3.2: Municipal Regulations & Guidelines.....	3
Section 4: Vehicle Management .....	3
4.1: Vehicular Traffic Control.....	4
4.2: Haul Route and Staging Areas .....	4
4.3: Vehicular Traffic Notifications .....	4
4.4: Emergency Vehicles .....	4
4.5: Parking .....	4
4.6: Bus Stops.....	4
4.7: Hazard Assessment.....	4
Section 5: Pedestrian Management .....	4
5.1: Pedestrian Protection .....	5
5.2: Pedestrian Safety .....	5
5.3: Pedestrian Traffic Notifications .....	5
5.4: Visually Impaired Persons.....	5
5.5: Accessibility .....	5
5.6: Hazard Assessment.....	5
5.7: Pedestrian Management Plans Rendering (PMPR) Signage .....	5
5.8: Pedestrian Detour Wayfinding Signage .....	5
Section 6: Encroachments & Disruptions .....	6

6.1: Demolition .....	6
6.2: Site Excavation .....	6
6.3: Site Services Connection.....	6
6.4: Construction Management Plan Element Inspection and Maintenance.....	6
6.5: Changes to the Construction Management Plan.....	7
Section 7: Environmental Factors.....	7
7.1: Damage to HRM Infrastructure .....	7
7.2: Protection of Trees .....	7
7.3: Line Painting and Temporary Crosswalks .....	7
7.4: Street and Right-of-Way Cleaning .....	7
7.5: Protection from Inclement Weather .....	7
7.6: Storm Water Management.....	8
7.7: Noise, Dust and Emission Control.....	8
7.8: Rodent Control .....	8
Section 8: Site Protection & Hoarding .....	8
8.1: Barriers & Fences.....	8
8.2: Snow removal .....	9
8.3: Gate Access and Egress.....	9
8.4: Hoarding Aesthetics.....	10
8.5: Sight Lines .....	10
8.6: Project Information and Contacts .....	10
Section 9: Lifting, Hoisting, and Crane Operations.....	10
9.1: Crane Use Overview .....	10
9.2: Transport Canada and Nav Canada Regulations.....	10
9.3: Aerodromes .....	10
Section 10: On-Site Safety and Security .....	10
10.1: Site Safety and Security Overview .....	10
10.2: Material Handling: Loading, Unloading, Delivery and Storage.....	11
10.3: Emergency Access & Egress.....	11
10.4: Security Site Lighting .....	11
10.5: Smoking Areas .....	11
10.6: Fire Suppression Systems .....	11

Section 11: Pre-Construction Consultation & Meeting ..... 11

    11.1: Pre-CMP Community Consultation..... 11

    11.2: Project Information and Contacts ..... 11

    11.3: Preconstruction Meeting..... 12

    11.4: Construction Notification ..... 12

Section 12: Summary..... 12

Appendix A – Encroachment Plan..... A

Appendix B – Traffic Control Plans TCP ..... B

Appendix C – Haul Route Plan ..... C

Appendix D – Pedestrian Management Plan (PMP) ..... D

Appendix E – Barrier, Fence & Gates Information..... E

Appendix F – Hoarding Information ..... F

Appendix G – Project Information Board ..... G

Appendix H – Project Safety Signage ..... H

Appendix I – Project Signage Specifications ..... I

Appendix J – Sample Traffic Notification Letter ..... J

Appendix K – Vehicular and Pedestrian Hazard Assessment ..... K

Appendix L – Community Consultation Records ..... L

Appendix M – HRM Tree Detail ..... M

Appendix N – Rodent Control Plan ..... N

Appendix O – CMP’s TCP & PMP Inspection Records..... O

Appendix P – Concrete Delivery Schematic..... P



Prepared by

G.K. MacLean, P. Eng.

In consultation with the landowner, contractor, traffic control company and HRM

## Section 1: Introduction

---

### 1.1: Project Description and Objectives

The landowner is planning to construct an apartment building on their consolidated land located on Herring Cove Road in Halifax. The consolidated lot formerly housed three buildings, that were previously demolished (civic 507, 509 and 513 Herring Cove Road). The new building will include 62 residential units within a 4-storey building with main level interior parking accessed from Herring Cove Road and exterior surface parking accessed Roy Street. This CMP has been prepared to address excavation, services and building construction.

Where the development is planned to have main level interior parking set at street level avoiding deep excavations fronting the HRM Right of Way (ROW) and given the building set back +/- 3.0m (+/-10ft) from the street line, no encroachments are planned within the HRM Right-of-Way (ROW). This will keep the public sidewalk open in front of the project throughout construction activities. Prior to excavation a row of interlocking F-type concrete barriers with chain link fencing mounted on top will be installed along the street line. All concrete operations and material deliveries will be staged within private property during construction with access gates stationed off Roy Street (private street). Two-way vehicular traffic and pedestrian traffic will be maintained along the Herring Cove Road.

Only during service work and driveway installations do we anticipate short term temporary lane drops or sidewalk closures on Herring Cove Road.

The project borders residential properties along its western and southern property lines, and residential properties to the north and east across Herring Cove Road and Roy Street. All neighbouring properties will remain undisturbed throughout the project.

This CMP document is intended to be an evolving document to help guide the project team to mitigate impacts to the adjacent community before they arise and to address unforeseen issues. SDMM, together with the Developer, contractor, and traffic control company, have prepared this Construction Management Plan (CMP) following HRM's CMP (2020) guidelines and administrative order (2018-005-ADM) in an effort to reduce potential negative impacts on the surrounding community, due to construction activities for this project.

The most up-to-date version of this document will be kept on-site at all times during construction. Should ownership or contracting services change throughout the course of this project, HRM will be notified immediately, and new parties will be required to comply with the approved CMP in writing.

## 1.2: Project Contact Information

The project team for the proposed development consists of:

Role	Name	Contact	Address	Phone
Landowner	AMK Barrett Investments Inc.	Adam Barrett	P.O. Box 27055, Halifax, NS, B3H 4M8	(902) 877-5560
Construction Manager	Sustainable Design and Construction Management	Logan McIntyre		(506) 899-2599 <b>24 Hour Emergency Contact</b>
Site Contractor	Atlantic Road Construction and Paving	Greg MacDonald	6 Belmont Avenue, P.O. Box 89 Eastern Passage, NS B3G 1M7	(902) 830-6411
Traffic Control Company	Frontline Traffic Services	Phil Pruneau	6 Belmont Avenue, P.O. Box 89 Eastern Passage, NS B3G 1M7	(902) 818-5548
Rodent Control Company	Rentokil Pest Control		51 Duke Street, Bedford, NS B4A2Z2	(902) 835-2304

## Section 2: Project Schedule and Logistics

The following is a brief summary of anticipated major project milestones broken down by phase:

### 2.1: Schedule

Project Phase	Start Date		End Date	Time Period
Rodent Control Program	Aug 28, 2023	-	Dec 11, 2023	4 Months
Site Excavation	Sep 11, 2023	-	Oct 11, 2023	1 Month
Substructure	Oct 9, 2023	-	Dec 23, 2023	2 Months
Superstructure	Dec 23, 2023	-	Feb 23, 2025	14 Months
Service Abandonments	Dec 1, 2024	-	Dec 14, 2024	2 weekends
Service installs	Dec 15, 2024	-	Dec 29, 2024	2 weekends
HRM Right of Way Flat Works	Aug 5, 2025	-	Aug 19, 2025	2 Weeks
Site Flat Works	Aug 5, 2025	-	Sep 5, 2025	1 Month

### 2.2: Key Dates

- Setup Barriers and safety fencing along property lines September 11, 2023
- Temporary sidewalk encroachments and/or temporary travel lane closures:
  - Herring Cove Road service abandonments December 1 – December 14, 2023
  - Herring Cove Road water service installs December 15 – December 29, 2023
  - Herring Cove Road sewer service install January 8 – January 29, 2024

The encroachment areas are shown in the appendix for reference.

### 2.3: Hours of Work

Work will generally take place during normal working hours as outlined in HRM's Noise By-Law and Traffic Control Manual Supplement; these are noted below.

- Monday to Friday: 7:00 a.m. – 9:30 p.m.
- Saturdays: 8:00 a.m. – 7:00 p.m.
- Sundays & Statutory Holidays: 9:00 a.m. – 7:00 p.m.
- Servicing Work: Noted Above

Although work is not expected to be required outside of the times listed above, if, for any reason, work is anticipated to be required outside of these hours, the contractor will apply to HRM for approval 5 business days (minimum) in advance of such work and obtain approval prior to proceeding. It is noted that HRM's Noise By-Law cannot be altered without HRM council approval; work must adhere to the Noise By-Law. Note that construction noise exemptions may be granted where construction noise is planned to take place during prohibited hours of the N-200 By-law. The developer to apply for this separately under the Construction Noise Exemption process.

## Section 3 – Relevant Regulations & Guidelines

---

### 3.1: Occupational Health & Safety Regulations

This CMP shall be utilized in agreement with all applicable Provincial and Federal Occupational Health and Safety Regulations. At a minimum, construction activities must at all times meet the standards of:

- a) National Building Code of Canada, as adopted and modified under the Building Code Act and the Nova Scotia Building Code Regulations made under that Act;
- b) Nova Scotia Occupational Health and Safety Act, and the Nova Scotia Occupational Safety General Regulations made under that Act;
- c) The Transportation Association of Canada (TAC)'s Manual of Uniform Traffic Control Devices for Canada (MUTCDC); and
- d) Nova Scotia Temporary Workplace Traffic Control Manual (NSTCM).

### 3.2: Municipal Regulations & Guidelines

In addition to the Provincial and Federal standards referenced in Section 3.1, this CMP shall be utilized in agreement with and meet, at a minimum, the standards of all relevant municipal by-laws including, but not limited to, the following:

- a) HRM Design Guidelines;
- b) HRM Standard Details;
- c) S-300 Streets;
- d) E-200 Encroachments;
- e) B-201 Building;
- f) N-200 Noise;
- g) T-600 Trees;
- h) S-900 Controlled Access Streets;
- i) T-400 Truck Routes;
- j) W-101 Discharge into Public Sewers;
- k) B-600 Blasting;
- l) HRM TCM Supplement;
- m) G-200 Grade Alteration and Stormwater management;
- n) Admin Order 2018-005-ADM regarding encroachments; and
- o) Admin Order 2020-010-OP regarding stormwater management standards for development activities.

## Section 4: Vehicle Management

---

Prior to any construction activity, all temporary workplace traffic control devices and signage will be in place as per the Nova Scotia Temporary Workplace Traffic Control Manual (latest edition). The traffic control company will install the signage and ensure that they are maintained throughout the project. This project's Traffic Control Plans (TCPs) are listed in the Appendix.



#### 4.1: Vehicular Traffic Control

A series of Traffic Control Plans (TCP) has been prepared by the traffic control company and is provided in the Appendix.

Throughout all phases of construction two-way vehicular traffic will be maintained along the Herring Cove Road. Only during service work do we anticipate short term temporary lane closures being required. Please refer to the appendices for required encroachment plan and traffic control plans.

#### 4.2: Haul Route and Staging Areas

The truck Haul Route Plan has been prepared by the traffic control company and is provided in the appendix.

The selected route is intended to minimize traffic congestion and maximize pedestrian safety. During all construction phases vehicles will enter and exit the site at the gate location(s) which will be clearly marked. Throughout all phases of construction, concrete and material deliveries shall be contained within private property.

#### 4.3: Vehicular Traffic Notifications

Should any traffic disruptions be required, notifications will be distributed to properties in the impacted area a minimum of five (5) days in advance of vehicular traffic closures. Refer to sample notification letter in the appendix.

#### 4.4: Emergency Vehicles

In the event of unforeseen emergency situations, the site will remain accessible to emergency vehicles at all times.

#### 4.5: Parking

Un-metered on street parking is not permitted along the Herring Cove Road in front of the project site. On street parking will not be affected by this project. It is noted that passenger vehicles are not permitted to park within any encroachment areas. To minimize parking requirements in adjacent neighbourhoods, site workers will utilize private property and workers will be encouraged to carpool or rely on public transit.

#### 4.6: Bus Stops

There is a bus stop directly across Herring Cove Road from the project site and one within the vicinity of the project site fronting civic 519. Bus service should not be affected by this project.

#### 4.7: Hazard Assessment

A vehicular and pedestrian hazard assessment is provided in the appendix. Any additional site hazards identified or encountered after work has commenced will be added to this list. All personnel on-site will be required to review this list and encouraged to identify additional potential hazards and hazard mitigation methods.

## Section 5: Pedestrian Management

---

A Pedestrian Management Plan (PMP) has been prepared by the traffic control company and is provided in the appendix.

Throughout all phases of construction, the public sidewalk will remain open in front of the project on the Herring Cove Road with the exception during service and driveway installations, where the sidewalk will be temporarily closed.

### 5.1: Pedestrian Protection

Pedestrians will be protected by physically distancing them from the project. A combination of F-type concrete jersey barriers with chain link fencing mounted above will delineate the project. Chain Link fencing will be covered with opaque covering to block view of the site. Refer to the appendix for examples of the barriers and fencing.

### 5.2: Pedestrian Safety

Pedestrian safety will be maintained by implementing appropriate signage as shown on the PMP. All navigation and safety signage indicating alternative sidewalks and potential hazards will be inspected and maintained regularly.

### 5.3: Pedestrian Traffic Notifications

Notifications will be distributed to properties in the impacted area a minimum of five (5) days in advance of pedestrian traffic impacts. A sample traffic notification letter can be found in the appendix. HRM must be notified prior to issuing the notification to neighbours.

### 5.4: Visually Impaired Persons

In keeping with CNIB requirements and as outlined on their 'Clearing Our Path' website; various items will be incorporated into the pedestrian management signage and barriers. Such as, high visibility contrasting colours with appropriate font types (mix of upper and lower-case lettering), font sizes (between 16mm to 51mm) and sign colours (orange background with black lettering or white background with black lettering).

The contractor will use bright orange sawhorse barricades complete with bold-font signage to identify sidewalk termination points. Sawhorse barriers will incorporate lower cross members, painted and marked consistent with the rest of the sawhorse, these added cross members will be placed near the ground to aid visually impaired persons using a cane. Reflective tape will also be placed on the ends of fencing, hoarding, sawhorse barricades, and concrete barriers to help delineate pedestrian routes and disruptions. Signage and tape colours will vary but will comply with the colour/brightness contrast as outlined by the CNIB website; examples are black/white, orange/black or dark red/white combinations.

### 5.5: Accessibility

High visibility signage will be used to assist pedestrians to easily navigate around all project related blocked sidewalks.

### 5.6: Hazard Assessment

A vehicular and pedestrian hazard assessment is provided in the appendix. Any additional site hazards identified or encountered after work has commenced will be added to this list. All personnel on-site will be required to review this list and encouraged to identify additional potential hazards and hazard mitigation methods.

### 5.7: Pedestrian Management Plans Rendering (PMPR) Signage

The need for a rendered map displayed for pedestrians showing the detoured pedestrian routes are not anticipated for this project.

### 5.8: Pedestrian Detour Wayfinding Signage

The need for pedestrian wayfinding signage directing pedestrians to adjacent businesses is not anticipated for this project.

## Section 6: Encroachments & Disruptions

---

During all construction activities, we are proposing that the project compound be limited to the property limits. Public sidewalks on the Herring Cove Road will only be utilized as described in section 1. No HRM ROW encroachments are anticipated for this project. To keep the public away from potential hazards a row of interlocking F-type concrete barriers complete with chain link fencing with opaque coverings will delineate the project site.

Throughout the project, fencing will be positioned to not obstruct vehicle sight lines. In areas adjacent to the site gates open mesh chain link or rigid fence on top of the site barriers to not obstruct sight lines.

Should any utility or traffic disruptions be required, the contractor will first apply to HRM for approval, a minimum of five (5) business days in advance of such work and will then notify neighbours of these disruptions in a timely fashion.

### 6.1: Demolition

Demolition is not required for this project.

### 6.2: Site Excavation

This includes deep excavation and removal of common site material. The development is planned only to have main level interior parking set at street level avoiding deep excavations fronting the Right of Way Herring Cove Road. If bedrock is found, the contractor will need to apply for a blasting permit and adhere to the HRM blasting by-law and conditions of the blasting permit. Alternatively, if a blasting permit can not be obtained the site's bedrock will be broken by a series of rock breakers to reach footing elevation.

### 6.3: Site Services Connection

This includes installation of new water and sewer laterals to their respective mains. The service installs will require modifications to the encroachment with temporary workplace signage incorporated (refer to the Service Installation Traffic Control Plans (TCP) in the appendix). HRM requires that this service work be limited to weekends only to minimize traffic disruptions. The target dates for this work are provided in the "Key Dates" section above with time of installations adhering to the Noise By-Laws noted above. The intent will be to complete this servicing work and reinstate the street as quickly as possible in order to minimize disruptions to the public.

Before scheduling site services connections, the contractor will notify all neighbouring properties, of the intended timeline for this work. A sample notification letter is included in the appendix.

The contractor intends to reinstate the street cut during the season of work. It is noted that street cuts cannot be left gravel or open. HRM reinstatement specifications must be met, and the travel way must be hard surfaced prior to reopening to the public. Asphalt, concrete curb and sidewalk reinstatement must be completed within 72 hours of disturbance and will be considered temporary if reinstated after October 31<sup>st</sup> or prior to May 1 in which case permanent reinstatement will be completed by June 15.

### 6.4: Construction Management Plan Element Inspection and Maintenance

Construction management plan elements will be inspected daily to ensure continued adherence to this CMP. Any deficiencies identified will be reinstated immediately. A CMP's TCP & PMP inspection report summary will be completed for the project, including information on what maintenance activities were conducted. This report must be kept on site at all times and be available to HRM upon request.

## 6.5: Changes to the Construction Management Plan

All departures from the CMP regardless of the significance must be submitted to the Municipality 10 days in advance for review and approval. Any required changes or modifications to the approved CMP will be submitted to HRM for review and approval prior to implementation.

## Section 7: Environmental Factors

---

### 7.1: Damage to HRM Infrastructure

Existing HRM infrastructure damaged during construction adjacent to the project will be reinstated and be completely replaced. This includes reinstatement of the HRM lawn, sidewalk, and curb and gutter post construction. It is anticipated that the sidewalks across the street will not be impacted by excavation or other construction activities. However, while efforts will be made to avoid damage, it is anticipated that some portions of existing curbs, gutters, and sidewalks may become damaged during the construction process which would require repairs or replacement. Pending HRM's review prior to and after construction and subject to damage due to construction activities, the landowner acknowledges that items may require to be fully replaced rather than repaired. The landowner also acknowledges that any costs incurred to repair or replace this public infrastructure are the responsibility of the owner.

For reinstatement timeline requirements, it is noted that asphalt, concrete curb and sidewalk reinstatement must be completed within 72 hours of disturbance and will be considered temporary if reinstated after October 31<sup>st</sup> or prior to May 1 in which case permanent reinstatement will be completed by June 15 of the following construction season.

### 7.2: Protection of Trees

There are nine (9) HRM street trees within the public right-of-way directly adjacent to the project site on Herring Cove Road. It is noted that HRM street trees shall not be touched prior to approval and/or compensation agreements between the landowner and HRM Urban Forestry are in place. Adjacent street trees are to be protected during construction in accordance with the HRM Tree Bylaw (T-600). Refer to HRM tree protection detail in the appendix.

Due to the planned driveway locations and new electrical duct bank, we are proposing to remove three (3) HRM street trees within the public right-of-way directly in front of the project on Herring Cove Road prior to project completion – a companion agreement will be required.

### 7.3: Line Painting and Temporary Crosswalks

Temporary line painting such as altered centreline or temporary crosswalk are not anticipated for this project.

### 7.4: Street and Right-of-Way Cleaning

The portion of public street adjacent to the project will be cleaned daily of any debris from trucks and silt, dirt, or rock that migrates beyond the encroachments. A sweeper truck will be utilized as required. Rock pads will be installed and maintained at all site entrances behind the curb line to knock dirt free from truck tires with aim to reduce off tracking of site soils.

### 7.5: Protection from Inclement Weather

To protect the public from construction debris during inclement weather, the project site will be enclosed by fencing complete with dust control covering, the site will be regularly reviewed and cleaned, with loose items secured when not in use.

## 7.6: Storm Water Management

During construction, nearby catch basins may be fitted with filter fabric to prevent debris from entering the storm system. Stormwater collected inside the project site will be directed to temporary stormwater settling ponds situated within the building footprint to allow clean water to be pumped into the existing public sewer systems in accordance with HW regulations and HRM By-law W-101 complete with appropriate fees to Halifax Water (HW). Sediment ponds may be shifted and positioned as desired by the site contractor during mass excavation however will generally be placed in localized low points within the building excavation.

## 7.7: Noise, Dust and Emission Control

The contractor will at all times adhere to the HRM Noise Bylaw (N-200) unless approved under HRM exemption process. No work will take place on the project site outside those hours identified in section 2 of this report, unless HRM grants an exception.

Dust mitigation for this project will be achieved using rock pads for trucks exiting the site. A water truck and sweeper truck will also be utilized to help prevent dust from becoming airborne and, when required, calcium may need to be used to mitigate dust migration. Additionally, mesh on the inside of the fencing will help to contain any airborne dust inside the site.

Breaking of rock may occur and rock faces cleared to form a wall. Mesh will be used on the inside of all construction fencing to mitigate dust control.

All construction vehicles will be required to use the loading area for parking and idling to keep exhaust emissions within the construction zone. Vehicles will be staged so that idling will not occur for more than 3 minutes at a time.

As indicated above, all work shall be completed in accordance with the HRM Noise By-Law.

## 7.8: Rodent Control

Rodent movement increases during construction activities. The owner has engaged a rodent control company, to utilize the established Rodent Control Plan (RCP) to help mitigate rodent movement prior to and during site excavation and building construction. The RCP applies to all project phases with the goal of preventing movement of rodents off-site. The RCP will consist of a baiting and monitoring program. Bait stations (traps) will be placed as outlined in the NPMA Pest Management Standards for Food Processing & Handling Facilities.

The RCP was engaged two weeks prior to the commencement of site excavation to help to lower the number of active rodents in the project area. Bait stations positioned along existing buildings and fence lines prior to excavation. Bait stations positioned along the edges of the project and secured in place using wooden stakes (for open sodded and dirt locations), weighted patio stones (behind walls and on paved areas), and zip-ties (fixed to fences) as per typical industry standards.

Refer to the appendix for a copy of the Rodent Control Plan.

# Section 8: Site Protection & Hoarding

---

## 8.1: Barriers & Fences

Throughout construction the project site will be delineated using interlocking F-type concrete jersey barriers complete with chain link depending on the proximity to street trees, with a total height (concrete barrier and fencing structure) being 1.8m or 6ft as per the noted administrative order. This fencing will be covered with an opaque dust

control mesh of high quality which will extend a minimum 3m from the public right-of-way. This screening is described in the appendix and will block passersby or tourists view of the construction site. Throughout the project, fencing will be situated to not obstruct vehicle sight lines. In addition, the adjacent street trees fronting Herring Cove Road will be protected as per HRM's tree protection details with orange snow fencing delineating the existing tree lawn between the sidewalk and street curb.

Along the private sidelines where traffic is present, the hoarding will be delineated by weighted modular 1.5m (5ft) high fencing or existing fencing where it is at least 1.5m tall. All fencing will have opaque dust control mesh and must be anchored down to prevent unintentional movement or overturning due to snow or wind loads.

The F-type barriers, fencing and tree protection defining the project site will adhere to the Encroachment Plan which is to scale includes dimensions and can be found in the appendix. These areas can be measured for the administering of applicable fees. Encroachment areas and fees will be based on the areas within the public right-of-way enclosed by the barriers and fencing.

Installation of F-Type concrete barriers, fencing and covering will take place during regular working hours as noted above. This work will be scheduled by the contractor after the HRM's pre-construction meeting has been held. HRM will coordinate this pre-construction meeting; the landowner, contractor and traffic control company will attend this site meeting. During the process of erecting and tearing down the traffic barriers, fencing and opaque covering defining the encroachment, traffic control elements will be implemented as per the Traffic Control Plan(s) in the appendix. All work and any traffic interruptions will be coordinated by the contractor who will notify HRM a minimum of 5 business days before work is scheduled to begin.

It is noted that surplus fencing must be stored and installed from private property when relocated for deliveries and be routinely re-established to keep the site secure. Surplus fencing cannot be stored within HRM's right-of-way.

## **8.2: Snow removal**

The landowner will be responsible to remove snow and ice as required to ensure that emergency access is maintain to the project site, this includes fire hydrants. The contractor will not dump snow or ice onto adjacent property and will truck snow off site as required to prevent the unsafe build-up of snow piles.

## **8.3: Gate Access and Egress**

The site will be accessible through gates. These gates are the only locations that will receive equipment/materials during construction, gates will remain closed and will be locked at all times after work hours. In cases of emergencies, on-site workers will exit the project site through these gates. These gates will remain unlocked at all times when workers are on site in case of emergency allowing unrestricted emergency response units access to the site.

Construction access gates are planned to be stationed along the property line at the existing driveway and the proposed rear parking lot driveway off Roy Street to facilitate deliveries. Gates are to swing into site, remain closed when not in use and locked after hours.

Any existing fire hydrants located adjacent to the site will remain protected from construction activities. These fire hydrants, along with the existing department connections will be accessible to firefighters throughout all phases of the project. Adjacent existing hydrants and fire department connections are not anticipated to be affected by construction.

#### 8.4: Hoarding Aesthetics

The site hoarding will resemble that shown in the appendix; encroachment fee reductions are not anticipated.

#### 8.5: Sight Lines

Rigid fencing and signage will be installed as per the CMP drawings such that vehicle sight lines are maintained around corners, particularly at driveway access points and existing intersections.

#### 8.6: Project Information and Contacts

To encourage communication between the project team and the public, contact information will be provided on Project Information Boards; these will be posted prominently around the project site on the fencing; refer to the appendix for a copy of the Project Information Board and the Encroachment Plan for the planned locations. Refer to the signage specification within the appendix describing the required size, materials, mounting hardware, etc. of these signs.

## Section 9: Lifting, Hoisting, and Crane Operations

---

### 9.1: Crane Use Overview

A tower crane is not anticipated for this project. Zoom boom, telehandlers, boom trucks and/or small mobile crane trucks will be brought to site to accommodate lifting and hosting materials to upper levels. Concrete placement will be facilitated by a concrete pump trailer and delivery trucks stationed within owner's private property (see concrete delivery schematic within the appendix). Material delivery trucks will be stationed within owners' private property and will be operated under the direct supervision of a licensed crane operator.

If lifting operations are required over the public realm, this area will be closed to access. In all cases of lifting, extreme care will be used to ensure public and worker safety.

### 9.2: Transport Canada and Nav Canada Regulations

We do not anticipate the use of a tower crane for this project.

### 9.3: Aerodromes

We do not anticipate the use of a tower crane for this project.

## Section 10: On-Site Safety and Security

---

### 10.1: Site Safety and Security Overview

The contractor will adhere to all Occupational Health & Safety requirements throughout the completion of this project. At a minimum, the following safety protocols will be utilized to further enhance site safety and security:

- a) All workers will be required to have proof of up-to-date safety training;
- a) Personal protective equipment (PPE) will be required for all personnel on site;
- b) Adequate signage will be placed outside the hoarding, which will warn of hazards that may exist;
- c) Gates will be locked and the perimeter fencing secured to provide security against public access during off work hours and will be monitored during operation;
- d) Hoarding will clearly state "No Trespassing – Construction Personnel Only" & PPE requirements will be clearly identified (e.g., "Hard Hats and Safety Footwear Must Be Worn Beyond This Point");
- e) Regular safety inspections will be conducted to ensure suitability of hoarding and other safety devices;

- f) Emergency contact information to be prominently posted as per the Project Information Board.

### **10.2: Material Handling: Loading, Unloading, Delivery and Storage**

The contractor will adhere to the procedures stipulated in the Haul Route Plan for delivery of materials. Delivery vehicles will use the designated gates for entry and exit. Timing of deliveries will be coordinated to have the least possible negative impact on regular traffic. The staging and delivery area will be coordinated by the delivery companies and site personnel, trucks will be housed within private property accessed from Roy Street.

### **10.3: Emergency Access & Egress**

The site will be accessible through gates to facilitate construction vehicle access. In cases of emergencies, on-site workers will exit the project site through these gates. These gates will remain closed but unlocked at all times when workers are on site in case of emergency allowing unrestricted emergency response units access to the site. Gates will be locked and secured afterhours to provide security against public access during off work hour. Emergency contact information will be posted on project information boards surrounding the site, refer to the CMP plan for details.

Gates are to remain closed at all times unless being used for deliveries to maintain a controlled access site preventing access by the general public to the construction site.

### **10.4: Security Site Lighting**

Security site lighting is not anticipated for this project.

### **10.5: Smoking Areas**

On site smoking areas will not be provided as this will be a smoke-free site.

### **10.6: Fire Suppression Systems**

There is one (1) existing fire hydrant along Herring Cove Road directly in front of the project site. Any existing fire department connections (FDC) adjacent to the site will remain outside the project area and distanced from construction activities. Fire hydrants, along with any existing FDCs will be accessible to firefighters throughout all phases of the project.

There are no proposed fire department connections as part of this project.

## **Section 11: Pre-Construction Consultation & Meeting**

---

### **11.1: Pre-CMP Community Consultation**

Due to the current pandemic, the landowner will forego the community consultation meeting. A construction notification letter will be delivered to the properties neighbouring the construction site as well as HRM staff, notifying them of the expected work with contact information for questions and feedback. As part of this notification the surrounding community and businesses will be offered to sign up for a monthly construction project notification from the development. It is understood, HRM requires a confirmation letter from the applicant confirming delivery of notification letters to affected residents. A map indicating these properties has been included in the appendix.

### **11.2: Project Information and Contacts**

To encourage communication between the project team and the public, contact information will be provided on Project Information Boards; these will be posted prominently around the project site on the fencing; refer to the



appendix for a copy of the Project Information Board and the CMP Plan for the planned locations. Information on signage size and materials is outlined in the appendix.

### 11.3: Preconstruction Meeting

Prior to construction the landowner, contractor and traffic control company will attend a pre-construction meeting with HRM staff to review the CMP document on site. HRM's engineering technician will confirm the date and time of this meeting; and may wish to waive the requirement.

### 11.4: Construction Notification

Approximately five (5) business days prior to the encroachment, an additional notification will be circulated to the neighbouring properties, notifying them that work is starting on site.

## Section 12: Summary

---

This construction management plan was prepared with the goal to minimize negative impacts to the community, pedestrians, and traffic throughout the scope of this project. This plan will be used as a minimum standard and any further safety protection required or methods to provide a more positive environment will be used throughout construction work as necessary.

Should you have any questions or comments related to this document, please contact SDMM. For all construction-related inquiries, please contact the landowner, contractor, or traffic control service provider.

Regards,

**Servant, Dunbrack, McKenzie & MacDonald Ltd.**

Geoff MacLean, P.Eng.

Project Engineer

Z:\SDMM\37000-37999\37050\37051\CMP\Rev1\507-513 HCR - CMP (Rev1) - 37051.docx

# APPENDIX

## Appendix A – Encroachment Plan

---

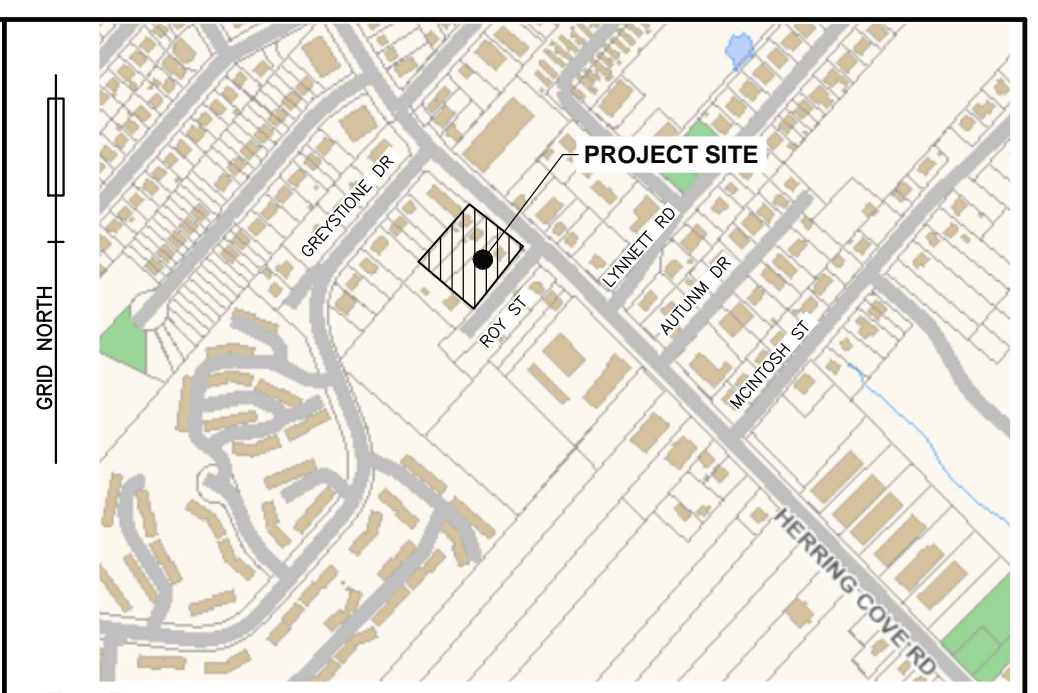
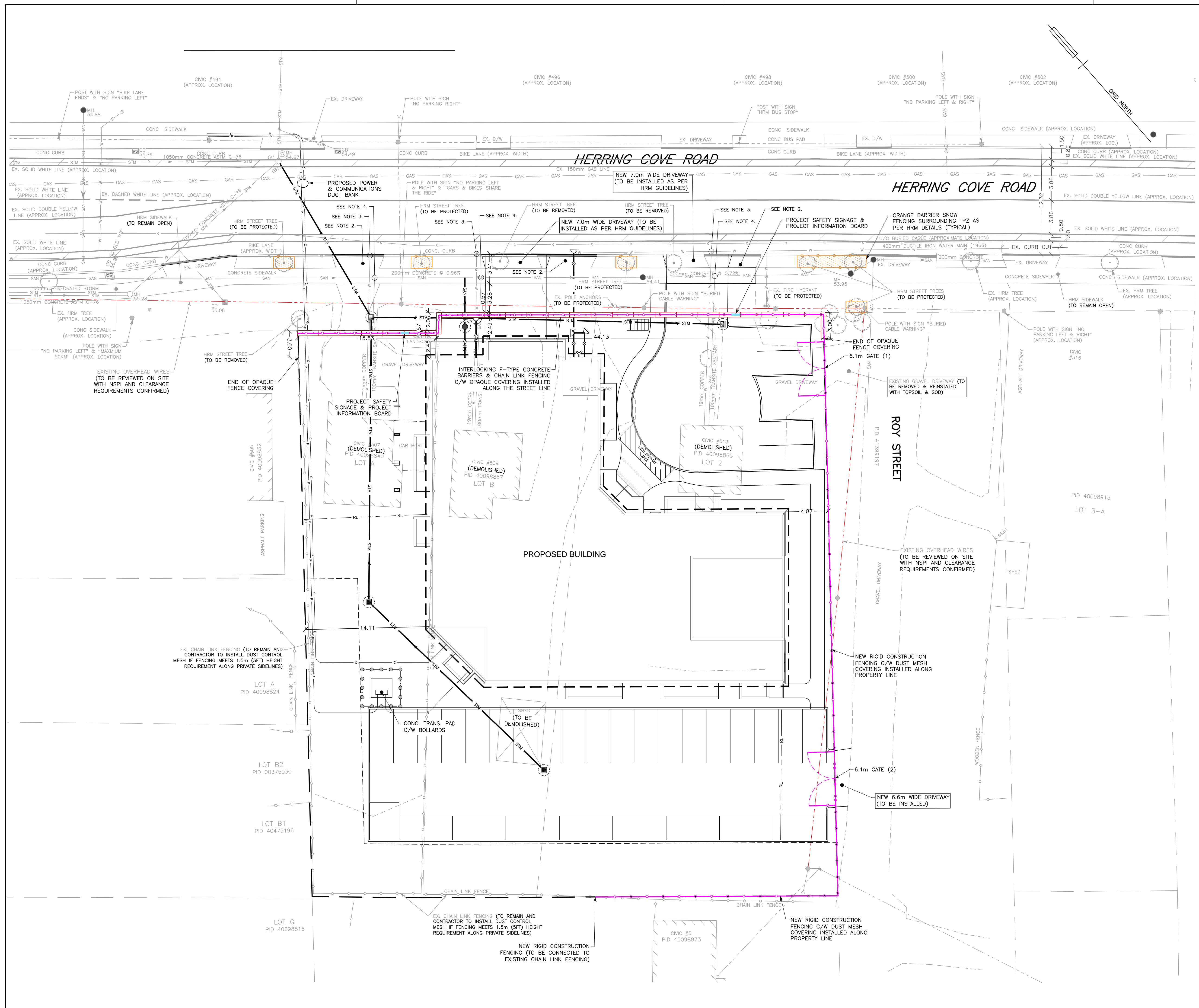

**LEGEND**

EXISTING	PROPOSED
25.0	25.0
25.0 BF	25.0 BF
CONTOUR LINE	CONTOUR LINE
CURB STOP/GATE/BUTTERFLY VALVE	CURB STOP/GATE/BUTTERFLY VALVE
FIRE HYDRANT	FIRE HYDRANT
CONCRETE THRUST BLOCK	CONCRETE THRUST BLOCK
SIAMSE CONNECTION	SIAMSE CONNECTION
CATCH BASIN/PIT	CATCH BASIN/PIT
CULVERT	CULVERT
ROCK LINING/DAM	ROCK LINING/DAM
ROCK WALL/RETAINING WALL	ROCK WALL/RETAINING WALL
POWER POLE & ANCHOR/LIGHT STANDARD	POWER POLE & ANCHOR/LIGHT STANDARD
TREE	TREE
STREET SIGN/PARKING METER	STREET SIGN/PARKING METER
ELEVATION/GRADE	ELEVATION/GRADE
125.00	125.00
TEST PIT	TEST PIT
DRAINAGE/SWALE FLOW DIRECTION	DRAINAGE/SWALE FLOW DIRECTION
WATER MAIN/SERVICE	WATER MAIN/SERVICE
SANITARY MANHOLE & PIPE	SANITARY MANHOLE & PIPE
STORM MANHOLE & PIPE	STORM MANHOLE & PIPE
COMBINED PIPE	COMBINED PIPE
GAS LINE	GAS LINE
100YR. FLOOD LIMIT	100YR. FLOOD LIMIT
GUARD RAIL	GUARD RAIL
UNDERGROUND CONDUIT	UNDERGROUND CONDUIT
OVERHEAD WIRES	OVERHEAD WIRES
PROPERTY LINE/BOUNDARY	PROPERTY LINE/BOUNDARY
FENCE	FENCE
BUILDING	BUILDING
TOP OF SLOPE	TOP OF SLOPE
TOE OF SLOPE	TOE OF SLOPE
TREELINE	TREELINE
LIMITS OF DISTURBANCE	LIMITS OF DISTURBANCE
TACTILE PEDESTRIAN PLATES	TACTILE PEDESTRIAN PLATES
PROJECT SAFETY SIGNAGE	PROJECT SAFETY SIGNAGE
ORANGE SANHORSE BARRICADE	ORANGE SANHORSE BARRICADE

- NOTES**
- THIS PLAN IS IN METRIC.
  - EXISTING DRIVEWAY CURB & RAMP TO BE REMOVED & REINSTATED WITH HIGH BACK CURB AND GUTTER AND TOPSOIL & SOD AS PER HRM SPECIFICATIONS.
  - EXISTING WATER SERVICE LATERAL TO BE ABANDONED.
  - EXISTING SEWER SERVICE LATERAL TO BE ABANDONED.
  - EXISTING CONDITIONS WITH APPROXIMATE LOCATIONS ARE BASED ON GOOGLE AERIAL IMAGERY AS SITE HAS NOT BEEN FIELD SURVEYED; DIMENSIONS MAY VARY AND SHALL BE CONFIRMED BY CONTRACTOR BEFORE PROCEEDING WITH CONSTRUCTION.

No.	YY/MM/DD	Revision	Description	Appr'd
1	23/09/29		REVISED AS PER HRM & HW COMMENTS	
0	23/06/21		ISSUED FOR REVIEW	

G.K. MacLean  
8978

**SDMM**  
Servant, Dunbrack, McKenzie & MacDonald Ltd.  
NOVA SCOTIA LAND SURVEYORS & CONSULTING ENGINEERS

36 QUAIL CRESCENT  
BIRDS LAKE BUSINESS PARK  
HALIFAX, NS B3S 1G6

PHONE: (902) 455-1537  
FAX: (902) 455-9479  
WEB: www.sdmm.co

**PROPOSED APARTMENT BUILDING**  
507, 509 & 513 HERRING COVE ROAD  
SPRYFIELD, NOVA SCOTIA

**ENCROACHMENT PLAN**

Date	Drawn	Project No.
JUNE 21, 2023	D. ANDERSON	FILE NO. 1-2-73 (37051)
Scale	Engineer	Plan No.
1:200	G. MACLEAN	
Reference	Approved	Drawing Name
--	G. MACLEAN	R1
Surveyed	Sheet	
SDMM		

0m 5 10 15 20m

## Appendix B – Traffic Control Plans TCP

---

# Encroachment Signage Plan

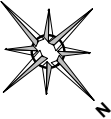

**Date:** 2023-10-11 **Author:** Norman Bussmann, TWS, Frontline Traffic Services, 902-817-3364 **Project:** 507,509,513 Herring Cove Rd  
**Contractor:** SDMM **Contact:** Geoff MacLean, 902-789-6374  
**Comments:**  
 Not to Scale  
 Encroachment Signage Plan  
 Off Shoulder Work Area  
 Sidewalk to remain open except as required by construction activities

Manifest
1 x TC-54L TC-54L
1 x TC-54R TC-54R

Legend
Gate
Site Fencing

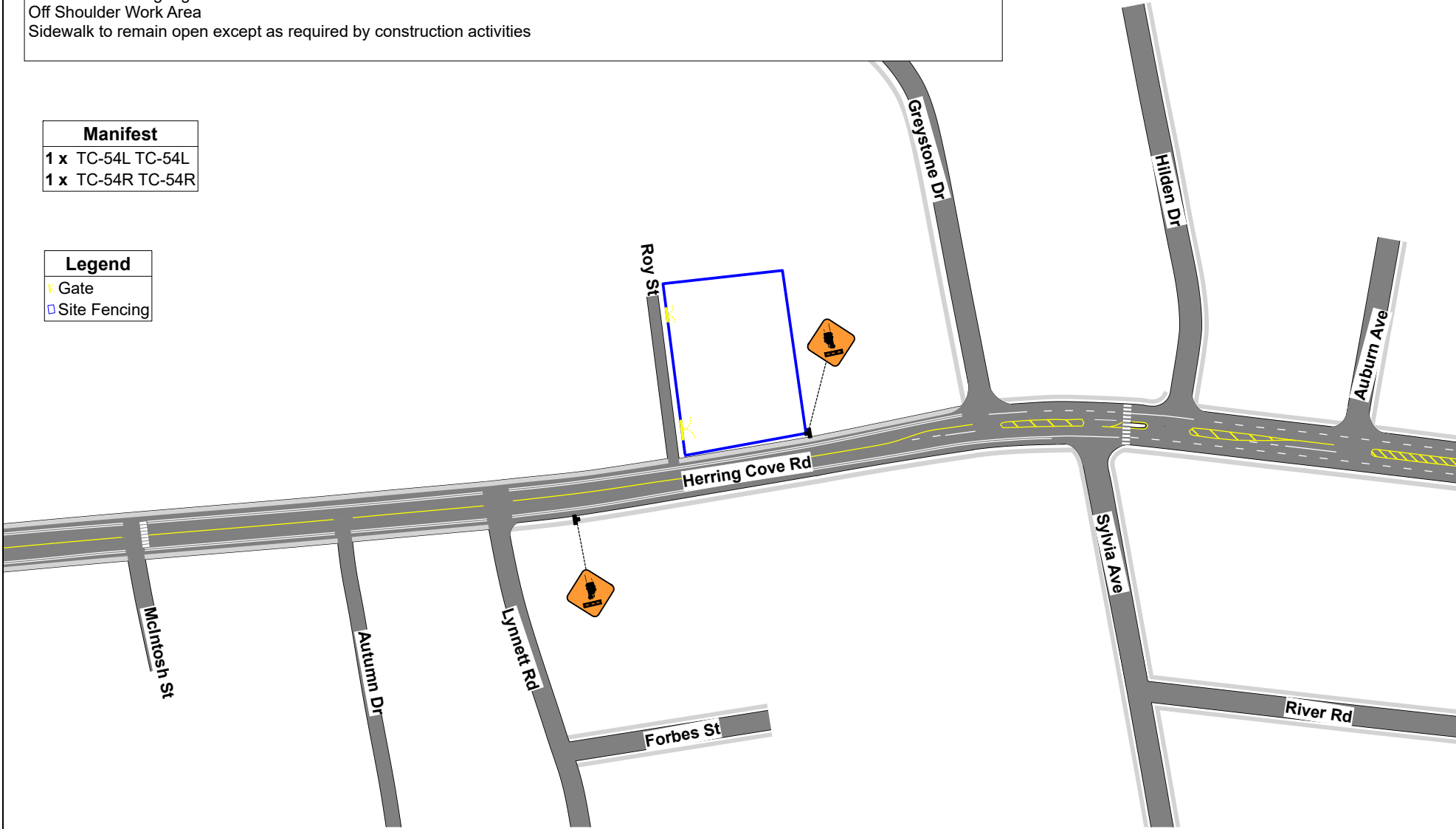

# Barrier Installation and Removal Plan

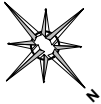

Date: 2023-10-11 Author: Norman Bussmann, TWS, Frontline Traffic Services, 902-817-3364 Project: 507,509,513 Herring Cove Rd  
Contractor: SDMM Contact: Geoff MacLean, 902-789-6374

Comments:  
Not to Scale  
Barrier Installation and Removal Plan  
Application Guide B35

Manifest	
16 x	Cone
9 x	TC-171 TC-171(NS) Speed Fines Double in Work Areas
7 x	Barrel
5 x	TC-2 TC-2
5 x	TC-4 TC-4
3 x	TC-21 TC-21
2 x	TC-1 TC-1
2 x	TC-21A (NS) TC-21A
1 x	TC-68
1 x	TC-72

Legend	
●	Barrel
▲	Cone
⌵	Gate
□	Site Fencing
■	Work Area

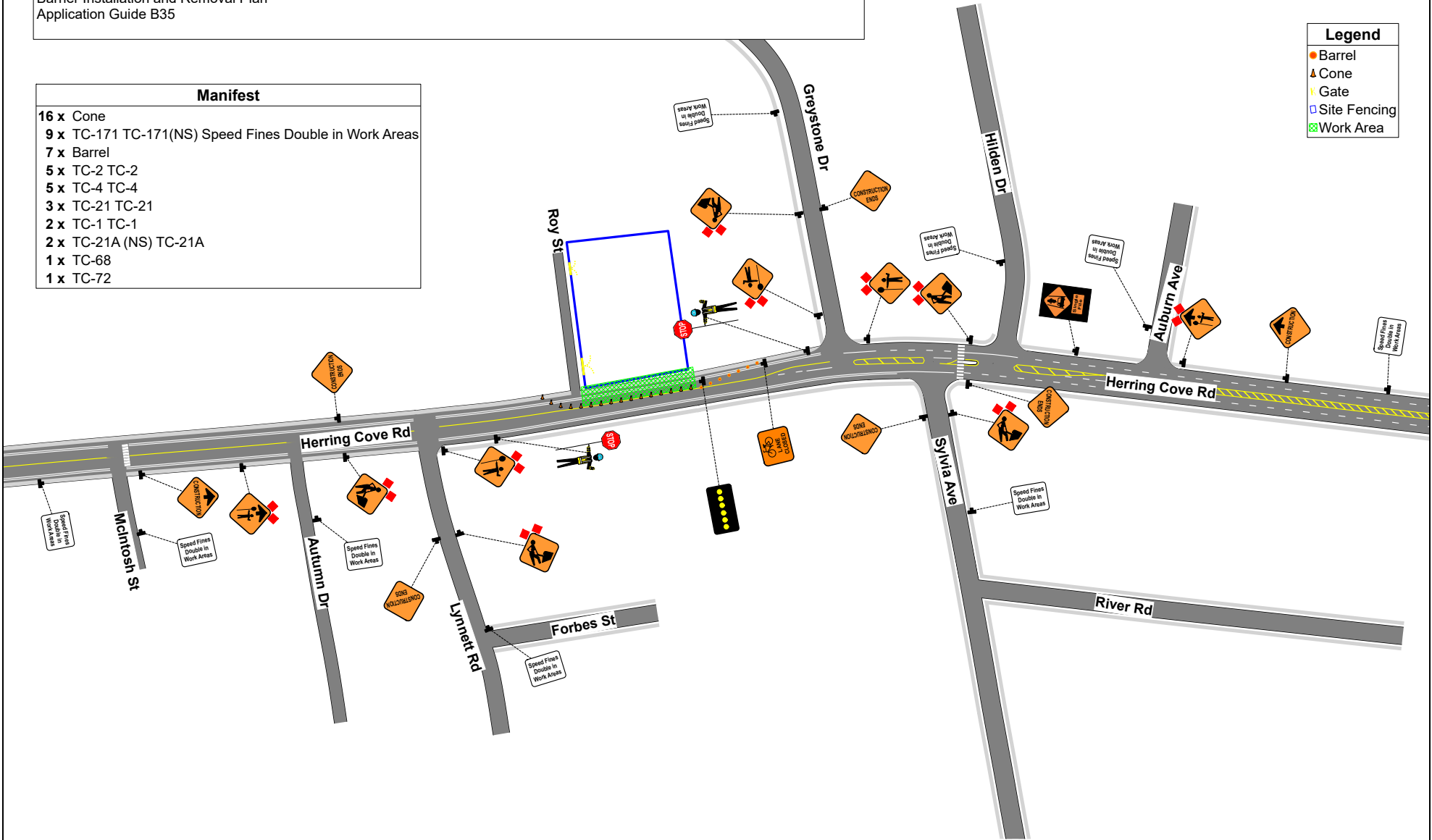





# Service Laterals Installation and Decommissioning Plan 1



**Date:** 2023-10-11 **Author:** Norman Bussmann, TWS, Frontline Traffic Services, 902-817-3364 **Project:** 507,509,513 Herring Cove Rd  
**Contractor:** SDMM **Contact:** Geoff MacLean, 902-789-6374  
**Comments:**  
 Not to Scale  
 Service Laterals Installation and decommissioning Plan  
 Application Guides A63R, B35, C112  
 On-site TWS must ensure compliance with operational rule 1.4 from section 13.3 of the NSTWTCM  
 See Pedestrian Management Plan for Sidewalk details

Legend	
●	Barrel
▲	Cone
⚡	Gate
□	Site Fencing
■	Work Area

I = 4m travel lane

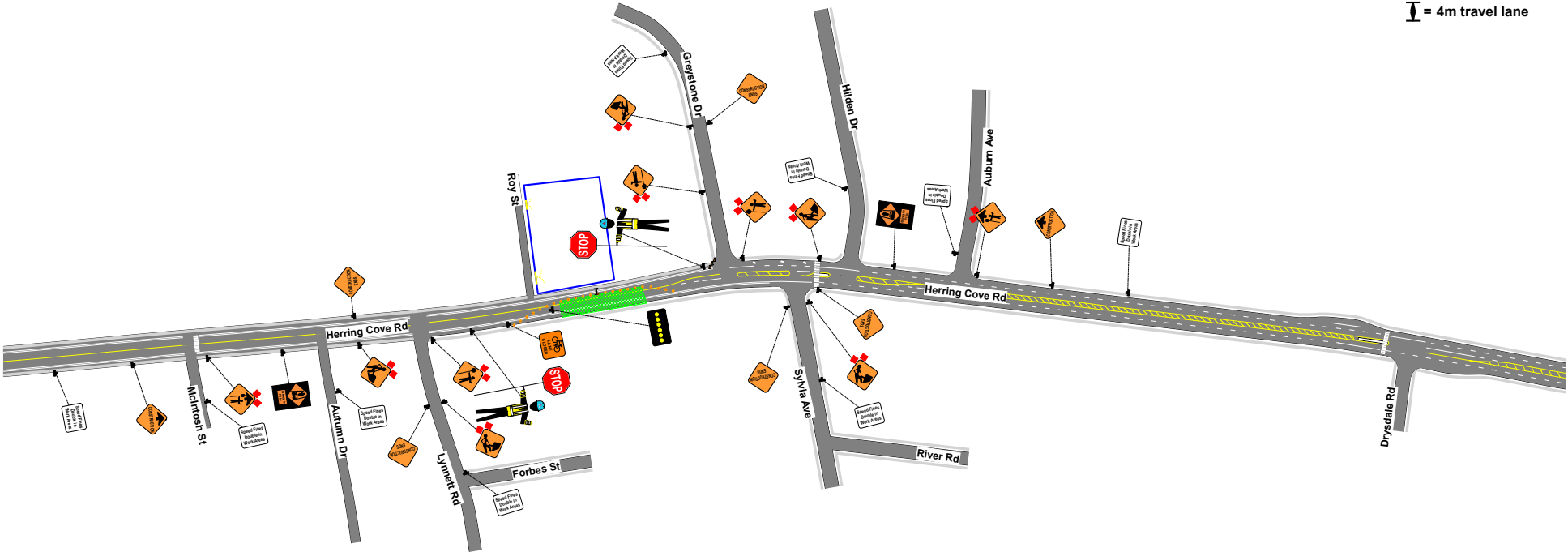

Manifest	
23 x	Barrel
9 x	TC-171 TC-171(NS) Speed Fines Double in Work Areas
5 x	TC-2 TC-2
5 x	TC-4 TC-4
3 x	Cone
3 x	1mRIGHTARROW
3 x	TC-21 TC-21
2 x	TC-1 TC-1
2 x	TC-21A (NS) TC-21A
2 x	TC-72
1 x	TC-68

# Service Laterals Installation and Decommissioning Plan 2



**Date:** 2023-10-11 **Author:** Norman Bussmann, TWS, Frontline Traffic Services, 902-817-3364 **Project:** 507,509,513 Herring Cove Rd  
**Contractor:** SDMM **Contact:** Geoff MacLean, 902-789-6374  
**Comments:**  
 Not to Scale  
 Service Laterals Installation and Decommissioning Plan 2  
 Application Guides A63R, B35, C112  
 On-site TWS must ensure compliance with operational rule 1.4 from section 13.3 of the NSTWTCM  
 See Pedestrian Management Plan for Sidewalk details

Legend	
●	Barrel
▲	Cone
⚡	Gate
▭	Site Fencing
■	Work Area

I = 4m travel lane

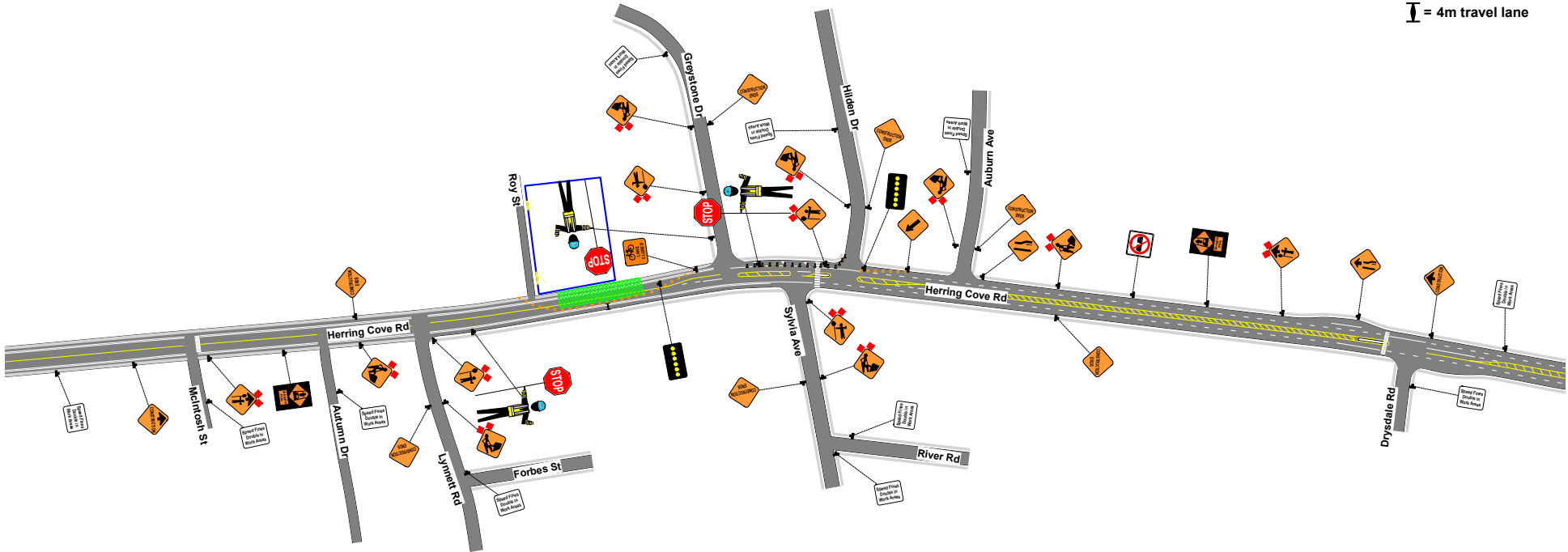

Manifest	
32 x	Barrel
16 x	Cone
11 x	TC-171 TC-171(NS) Speed Fines Double in Work Areas
7 x	TC-2 TC-2
7 x	TC-4 TC-4
4 x	TC-21 TC-21
3 x	lmRIGHTARROW
2 x	TC-1 TC-1
2 x	TC-21A (NS) TC-21A
2 x	TC-72
1 x	RB-31
1 x	TC-5R TC-5R
1 x	TC-5RA (NS) TC-5RA
1 x	TC-6 TC-6
1 x	TC-68

# Curb, Sidewalk and Driveway Plan

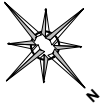

Date: 2023-10-11 Author: Norman Bussmann, TWS, Frontline Traffic Services, 902-817-3364 Project: 507,509,513 Herring Cove Rd  
Contractor: SDMM Contact: Geoff MacLean, 902-789-6374

Comments:  
Not to Scale  
Curb, Sidewalk and Driveway Plan  
Application Guide B35  
On-site TWS must ensure compliance with operational rule 1.4 from section 13.3 of the NSTWTCM  
See Pedestrian Management Plan for sidewalk closure details

Manifest	
16 x	Cone
9 x	TC-171 TC-171(NS) Speed Fines Double in Work Areas
7 x	Barrel
5 x	TC-2 TC-2
5 x	TC-4 TC-4
3 x	TC-21 TC-21
2 x	TC-1 TC-1
2 x	TC-21A (NS) TC-21A
1 x	TC-68
1 x	TC-72

Legend	
●	Barrel
▲	Cone
⚡	Gate
□	Site Fencing
■	Work Area

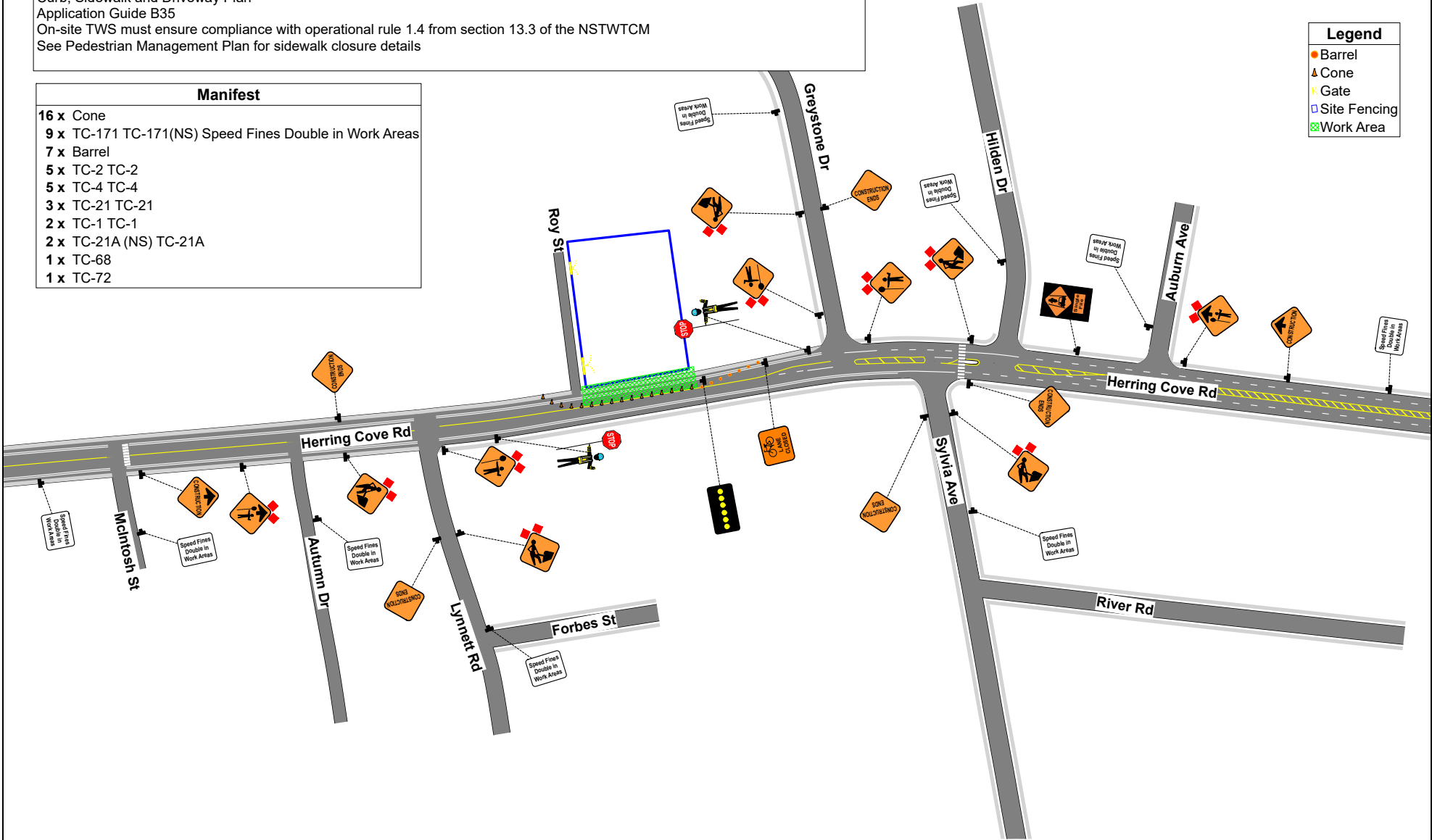

## Appendix C – Haul Route Plan

---

# Haul Route Plan

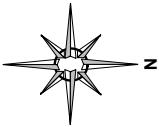

**Date:** 2023-10-11 **Author:** Norman Bussmann, TWS, Frontline Traffic Services, 902-817-3364 **Project:** 507,509,513 Herring Cove Rd  
**Contractor:** SDMM **Contact:** Geoff MacLean, 902-789-6374

**Comments:**

Not to Scale

Haul Route Plan

Inbound via Dunbrack St to Old Sambro Rd to Dentith Rd to Herring Cove Rd to Roy St

Outbound via Roy St to Herring Cove Rd to Dentith Rd to Old Sambro Rd to Dunbrack St

**Legend**

- ▼ Haul Route Inbound
- ▲ Haul Route Outbound

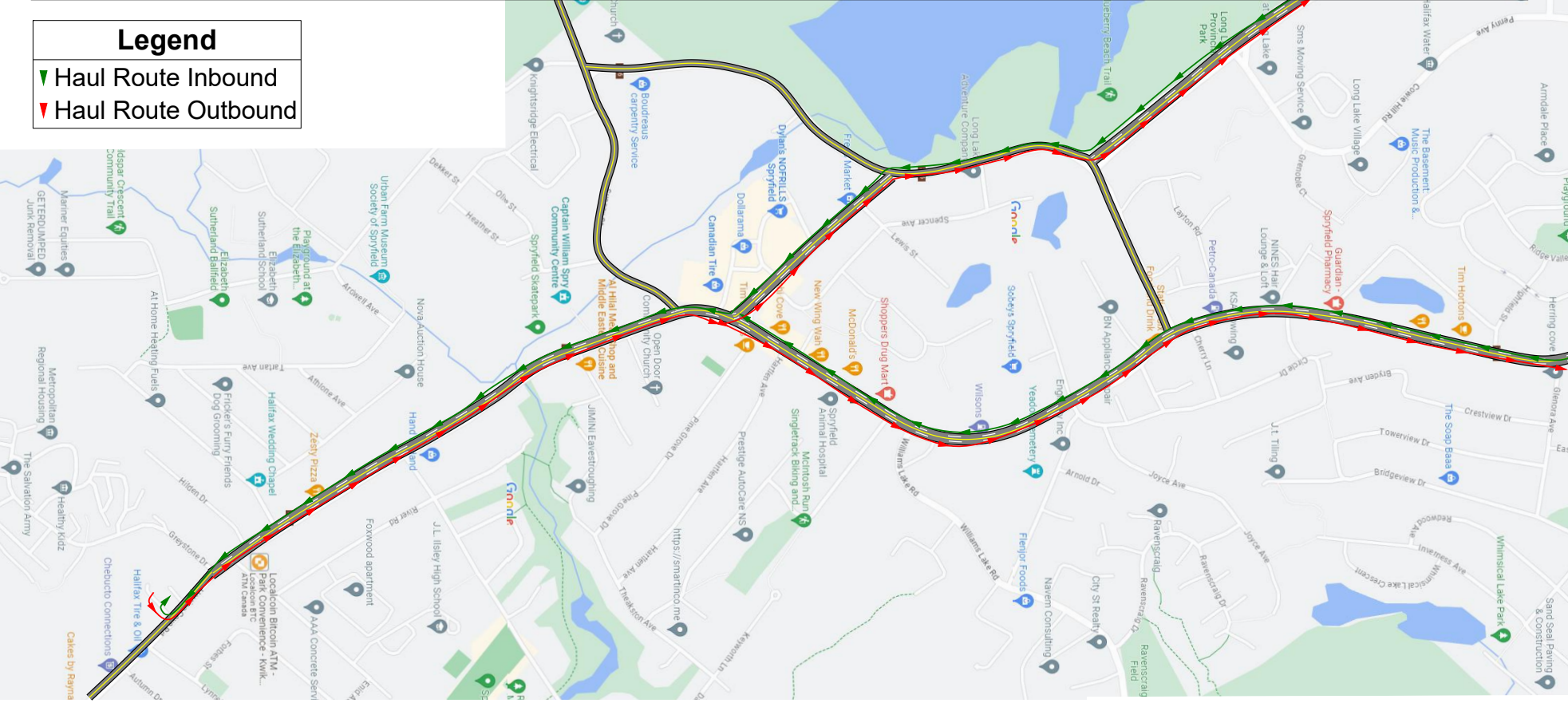

## Appendix D – Pedestrian Management Plan (PMP)



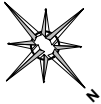

---

# Pedestrian Management Plan



**Date:** 2023-10-11 **Author:** Norman Bussmann, TWS, Frontline Traffic Services, 902-817-3364 **Project:** 507,509,513 Herring Cove Rd  
**Contractor:** SDMM **Contact:** Geoff MacLean, 902-789-6374  
**Comments:**  
 Not to Scale  
 Pedestrian Management Plan  
 Use this Plan as required for construction activities  
 Sidewalk to remain open at all other times

**Legend**

-  Gate
-  Pedestrian Path
-  Site Fencing
-  Work Area

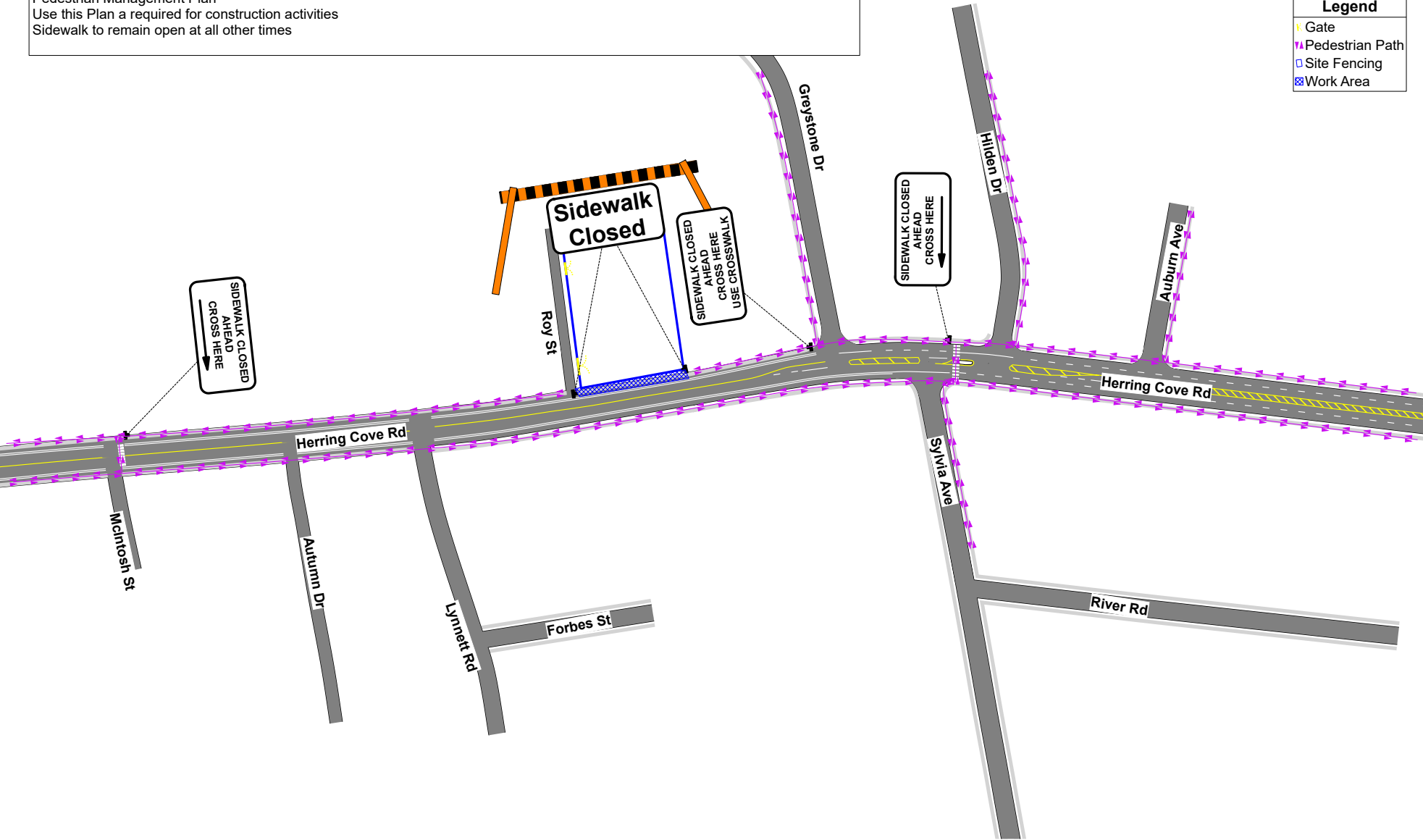

## Appendix E – Barrier, Fence & Gates Information

---



# Sample Barrier & Fence Details

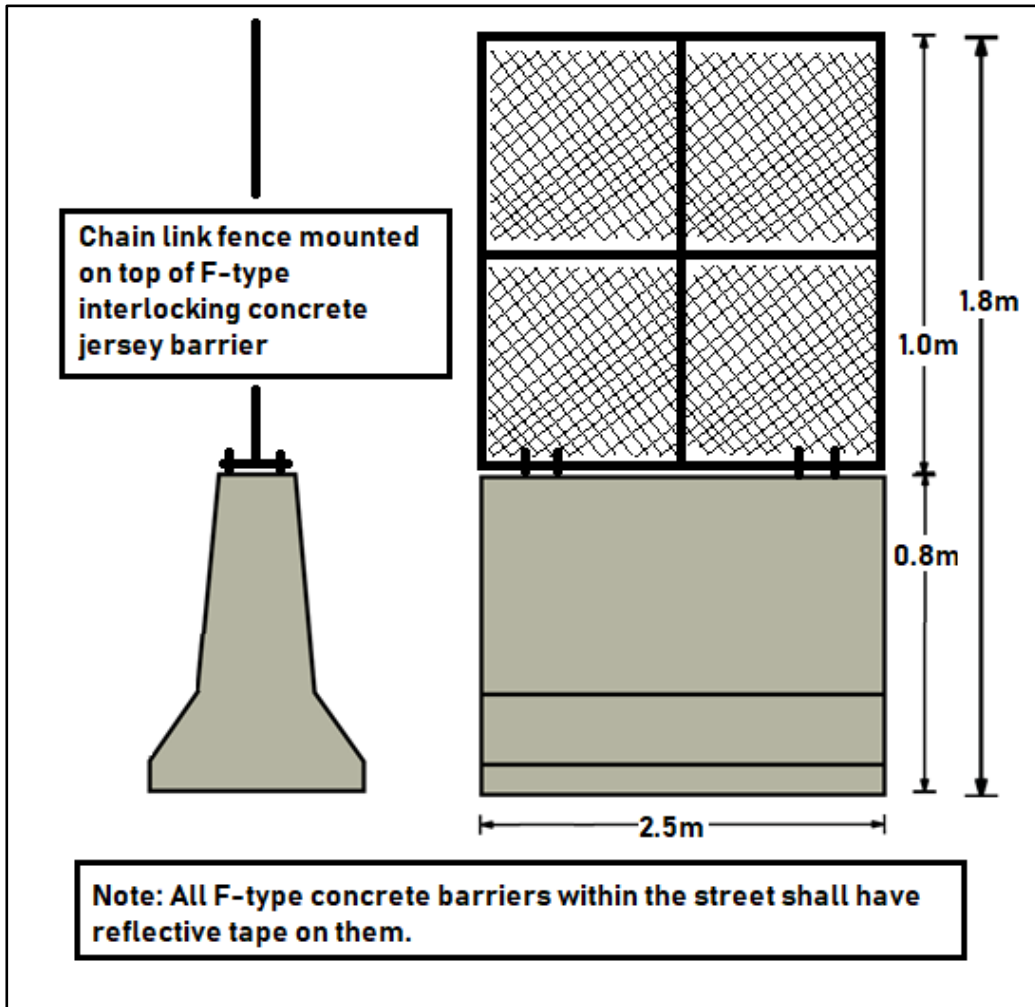
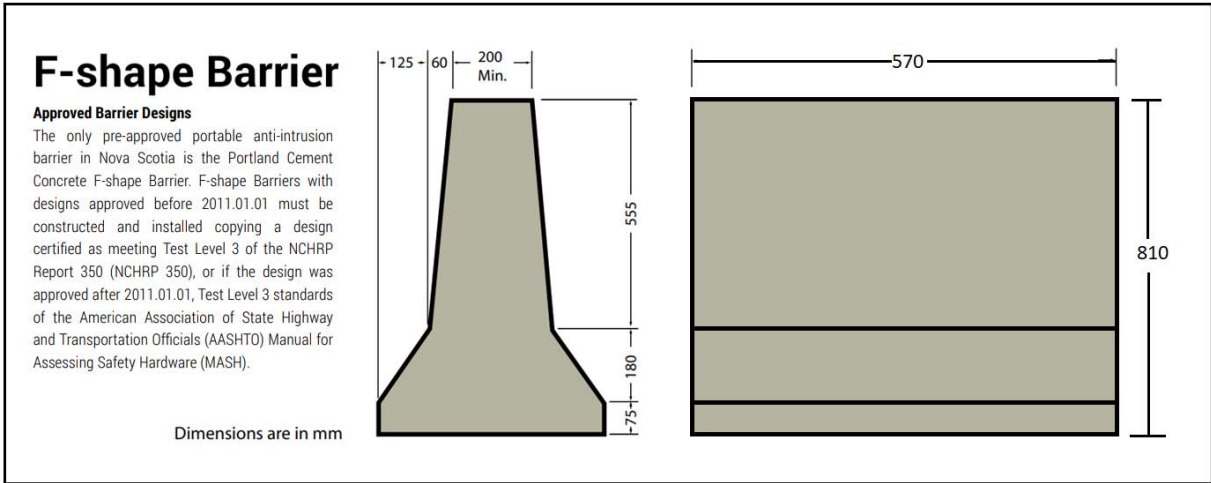

Fence mounted to curb with interlocking F-type concrete jersey barriers set beside

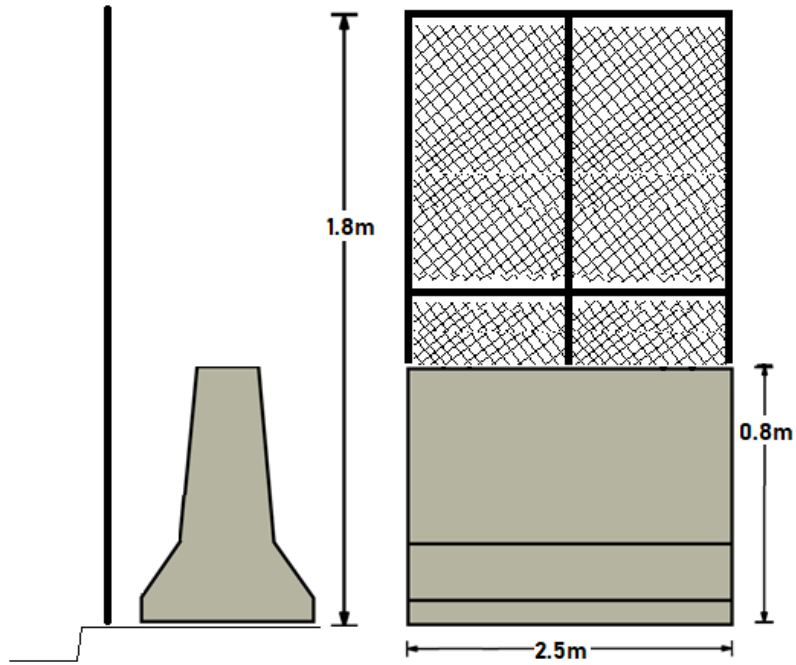

Note: All F-type concrete barriers within the street shall have reflective tape on them.

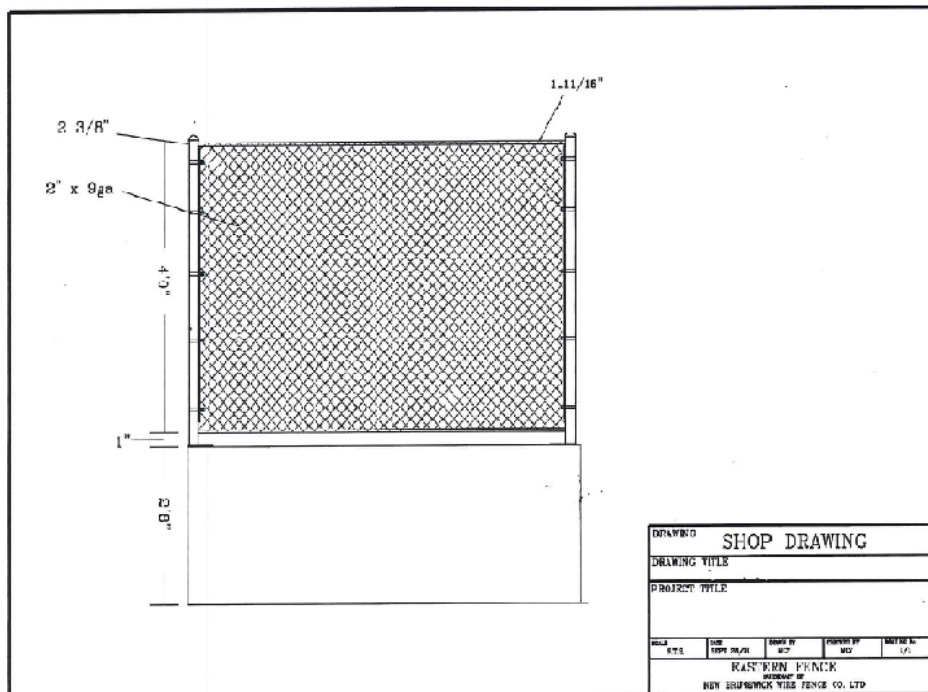

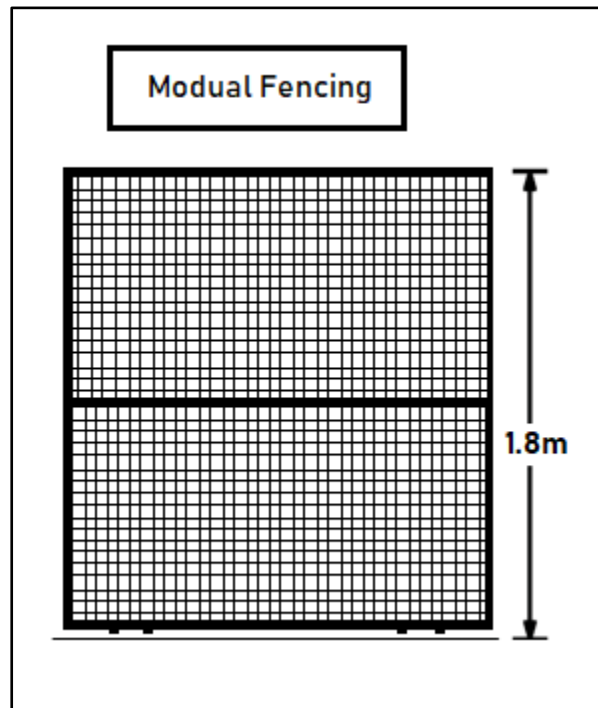
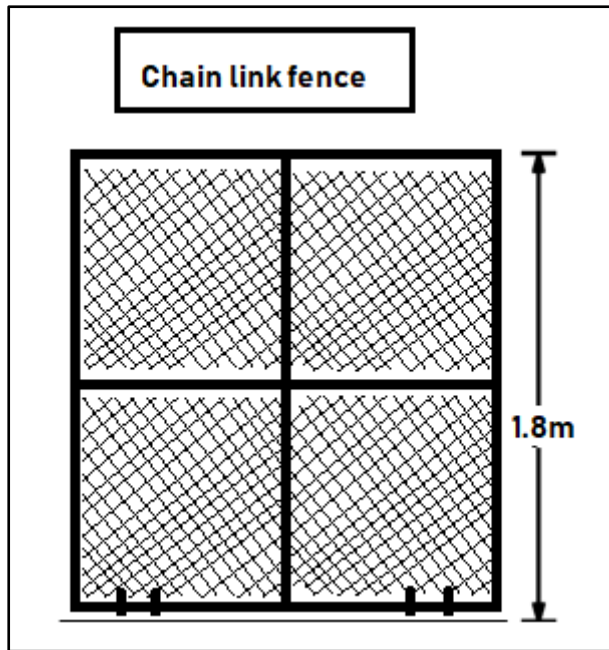

Sample Gate Detail

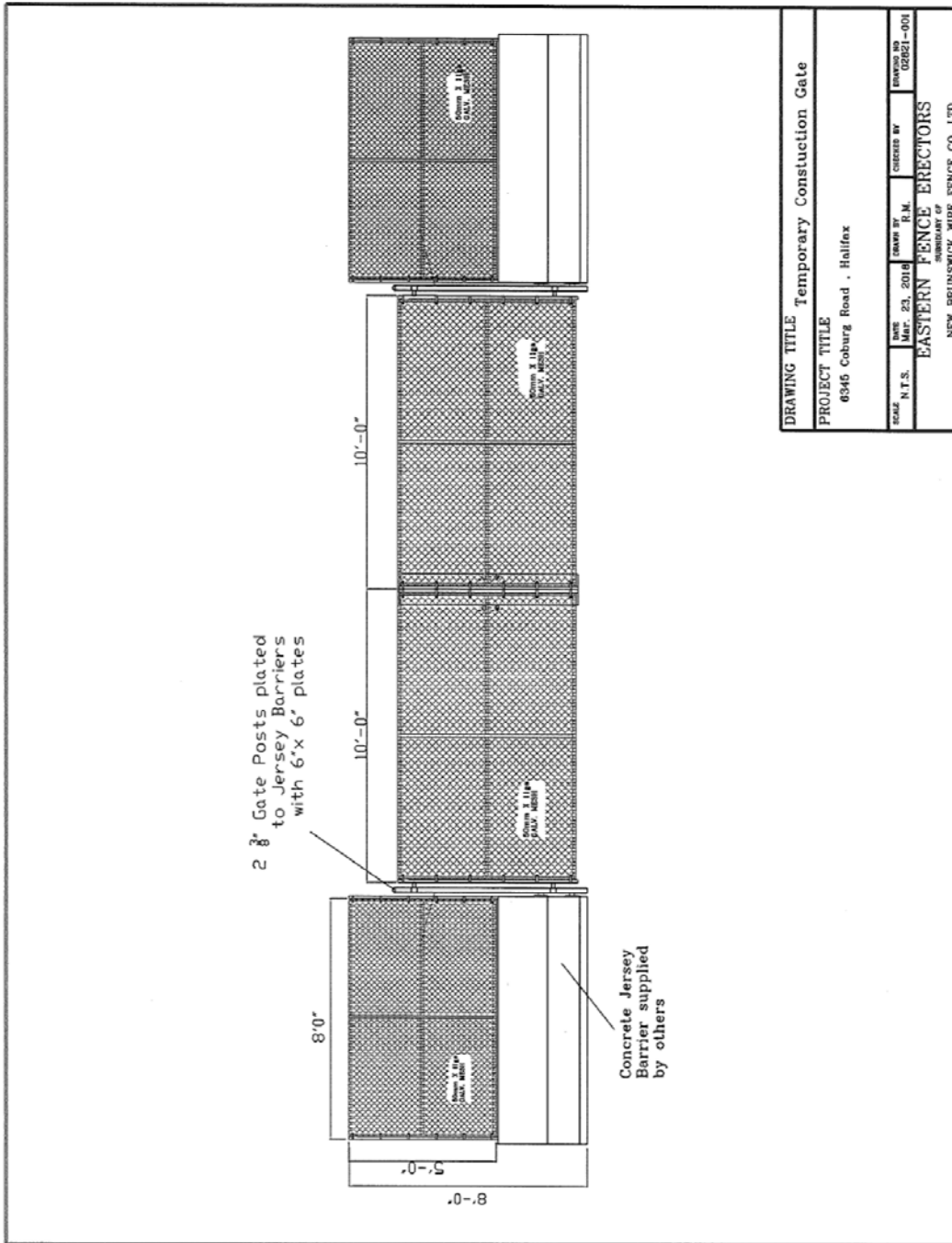

DRAWING TITLE Temporary Construction Gate			
PROJECT TITLE 6345 Coburg Road . Halifax			
SCALE N.T.S.	DATE Mar. 23, 2018	DRAWN BY R.M.	CHECKED BY DDB21-001
EASTERN FENCE ERECTORS NEW BRUNSWICK WIRE FENCE CO. LTD			

## Appendix F – Hoarding Information

---

Opaque construction hoarding material shall covering and be adequately secured to the rigid fencing that outlines the encroachment area. This covering shall be continuous such that it prevents passersby or tourist from seeing through the fencing and gates to the active construction site.

UltraMesh® Eclipse® if a 7.96 oz. which is a polyester, black-backed mesh that is used where complete opacity is required.

UltraMesh Eclipse is UV printable for project renderings and is typically used for building and fence graphic wraps. The product is available in widths of 126" and 196".

Product example is shown below with the technical data sheet on the following page.

Tarp Option



Print Banner Option



UltraMesh Eclipse is a 7.96 oz. polyester, black-backed mesh. The material is ideal for applications where complete opacity is required. UltraMesh Eclipse is UV printable and may be used for building wraps and fence graphics. Available in widths of 126 and 196 .

### Material Details

CHARACTERISTICS	TEST METHOD	METRIC	ENGLISH
Base Fabric	100% PES	1000D×1000D	
Construction			12×12
Total Weight	DIN53352 BS3424 Method5A	270 +/- 20 gsm/m <sup>2</sup>	7.96 oz/yd <sup>2</sup>
Width		Up to 500cm	
Tensile Strength	DIN53352 BS3424	Warp 1250 n/5cm Weft 1100 n/5cm	142.75 x 130.19 lb/in
Tear Strength	DIN53356 BS3424	Warp 235 N Weft 225 N	52.8 x 50.5 lbf
Air Permeability	GB/T 2410-2008		2649 mm/s
Light Transmission	GB/T 5453-1997		37%
Temperature Resistance	DIN53357 BS3425 Method 10		-20°C /70°C

### Applications

	Back-lit	Banner	Billboard	Block-out	Building Wrap	Fence Graphics	Truckside
Applications		■		■	■	■	

### Ink Printability

Solvent	Eco Solvent	UV	Latex	Screen Printing	Dye Transfer	Dye Direct
		■				

### Available Sizes

Metric (m)	English (inches)
3.20, 5.00	126 , 196

The information on physical and chemical characteristics is based upon tests believed to be reliable. The values are intended only as a source of information. A legally binding guarantee of specific properties is not to be inferred from our specifications. They are given without guaranty and do not constitute a warranty. A weight variance of +1/-2 is acceptable. The purchaser should independently determine, prior to use, the suitability of this material for his/her specific purpose. (Data represents averages and is not intended for use as a specification.)



## Appendix G – Project Information Board

---



**PROPOSED MULTI-UNIT BUILDING  
Herring Cove Road**

4 Storey – Residential Building

62 Residential Units on 4 Levels

Mixture of Studio and 2 Bedroom Units

Main Level Interior Parking and Exterior  
Surface Parking

Indoor Bicycle Parking and Storage

**September 2023 – September 2025**

**Developer:**

AMK Barrett Investments Inc.

P.O. Box 27055, Halifax, NS

**24 Hour Contact:**

**Adam Barrett – (902) 877-5560**

**Site Contractor:**

Atlantic Road Construction and Paving

6 Belmont Avenue, P.O. Box 89, Eastern Passage, NS, B3G 1M7

**Contact:**

Greg MacDonald – (902) 830-6411

**Traffic Control:**

Frontline Traffic Services

6 Belmont Avenue, P.O. Box 89, Eastern Passage, NS

**Contact:**

Phil Pruneau – (902) 818-5548

**Rodent Control Company:**

Rentokil Pest Control

51 Duke Street, Bedford, Bedford, NS

**Contact:**

Main Office – 902- 835-2304

## Appendix H – Project Safety Signage

---

**NO  
TRESPASSING**

 **WARNING**

**CONSTRUCTION SITE**

To reduce risk of injury,

- Hard Hat
- Safety Shoes

**MUST** be worn on this site.

**RESTRICTED**  
**— AREA —**

**CONSTRUCTION**  
**WORK IN**  
**PROGRESS**

## Appendix I – Project Signage Specifications

---

Signage Specifications: Project Signage shall;

- Be constructed of weatherproof material (corrugated plastic)
- Have high visibility contrasting colours (dark letters on white background)
- Incorporate appropriate font types (mix of upper and lower-case lettering)
- Incorporate appropriate font sizes (16mm – 51mm) such that the signage is readable from a distance (16-20m)
- Size of signage will be poster size (600mm x 900mm) or larger; to allow community members to see and read the information from a distance
- Signage may incorporate plastic grommets positioned every 300mm around the perimeter of the signage to ensure a secure signage installation
- Signage will be installed/anchored to project fencing using plastic zip-ties
- Signage will be positioned along the project site as per the encroachment plan
- Signage shall not impede traffic of pedestrian sight lines
- **Signage shall be placed on site 10 days prior to the start of the noted construction activity to ensure the passing public has had adequate time to review, adjust their travel patterns, usage of streets and or can be considered 'informed'.**

Samples



## Appendix J – Sample Traffic Notification Letter

---





## Proposed Multi-Unit Residential Building

### DRAFT NOTIFICATION LETTER

### TO WHOM IT MAY CONCERN

### Date

### NOTIFICATION OF TRAFFIC DISRUPTION: STREET NAME, HALIFAX, NOVA SCOTIA

This is to inform you that the to facilitate operations in association with the building construction work, traffic disruptions will occur on or about DATE with an anticipated duration of approximately TIME. The street will be reduced(?) to one lane of vehicular traffic during this time.

Should you have any questions or concerns please feel free to contact the below:

### CONTACT INFORMATION

Site Contractor:

### Atlantic Road Construction and Paving

6 Belmont Avenue, P.O. Box 89

Eastern Passage, NS, B3G 1M7

Phone: (902) 830-6411

Should any questions arise, please feel free to contact the undersigned.

Yours Truly,

Greg MacDonald

Atlantic Road Construction and Paving.

## Appendix K – Vehicular and Pedestrian Hazard Assessment

---

Project

Date:

Location:

VEHICULAR & PEDESTRIAN HAZARD ASSESSMENT

No.	Hazard:	Project Phase:	Vehicular Impacts:	Mitigation Methods:	Pedestrian Impacts:	Mitigation Methods:
1	Excavation	Excavation	Vehicles may enter project site and fall down excavation.	Place concrete barriers along travel ways. Concrete barriers and existing curbs to prevent vehicle entry.	Pedestrians may enter project site and fall down excavation.	Place concrete barriers/rigid fencing around entire project site.
			Vehicle weight may surcharge excavation, causing excavation wall failure.	Close sidewalks & driveways adjacent to project site, moving vehicles farther away from excavation.		
2	Rock Blasting	Excavation	Blasted rock projectiles may strike vehicles.	Close sidewalks & driveways adjacent to site, moving vehicles farther away from blasted rock.	Blasted rock projectiles may strike pedestrians.	Install solid plywood hoarding along rigid fence adjacent to blasting zone.
3	Construction Waste	All Phases	Vehicles may be struck by construction waste.	The contractor shall keep the project site and surrounding areas clean and free of construction debris.	Pedestrians may be struck by construction waste.	The contractor shall keep the project site and surrounding areas clean and free of construction debris.
4	Vehicular & Pedestrian Activities	All Phases	Drivers and pedestrians may become confused or impatient with construction activities. Pedestrians may walk in unmarked crosswalks or in vehicular travel areas. Drivers may fail to obey traffic signage.	Vehicular and pedestrian signage will be posted prominently around the project site to facilitate pedestrian movement. Notification will be sent prior to all traffic interruptions.	Drivers and pedestrians may become confused or impatient with construction activities. Pedestrians may walk in unmarked crosswalks or in vehicular travel areas. Drivers may fail to obey traffic signage.	Vehicular and pedestrian signage will be posted prominently around the project site to facilitate pedestrian movement. Notification will be sent prior to all traffic interruptions.
5	Heavy Machinery Operation	All Phases	Heavy machinery or vehicles may break down or overturn, damaging other vehicles.	The contractor shall maintain safe distances between vehicles and heavy machinery on-site. Concrete barriers will be installed to separate construction vehicles from public traffic.	Heavy machinery or vehicles may break down or overturn, injuring pedestrians.	The contractor shall maintain safe distances between pedestrians, vehicles, and heavy machinery. Rigid fences will be installed to separate construction vehicles from pedestrians.
			Heavy machinery or vehicles may overturn due to uneven terrain, damaging other vehicles.	The contractor shall maintain safe distances between vehicles and heavy machinery on-site and ensure travel routes are kept flat.	Heavy machinery or vehicles may overturn due to uneven terrain, injuring pedestrians. Pedestrians may walk on uneven terrain causing them to twist their ankles or fall.	The contractor shall maintain safe distances between pedestrians, vehicles, and heavy machinery and ensure travel routes are kept flat.
6	Construction Signage	All Phases	Construction signage may strike vehicular traffic.	Construction signage will be securely fixed to existing poles, temporary concrete sign bases, or rigid fences.	Pedestrians may walk into construction signage, including traffic signage, wayfinding signs, etc. may.	Signage will be angled in line with pedestrian routes and/or be placed at heights such that they do not pose a risk to pedestrians.
					Construction signage may strike pedestrians.	Construction signage will be securely fixed to existing poles, temporary concrete sign bases, or rigid fences.
7	Dangerous Materials	All Phases	Flammable, explosive, & hot materials may damage vehicles if not properly maintained & stored.	The contractor will use and store dangerous materials properly as per manufacturers' specifications.	Flammable, explosive, & hot materials may injure pedestrians if not properly maintained & stored.	The contractor will use and store dangerous materials properly as per manufacturers' specifications.
8	Hoisting Operations	Superstructure	Precast concrete panels and other items hoisted may fall from heights and damage vehicles.	Proper hoisting and lifting techniques will be used to ensure that materials do not fall from heights. F-Type concrete barriers will be installed such that loads are never suspended above the public realm.	Precast concrete panels and other items hoisted may fall from heights and injure pedestrians.	Proper hoisting and lifting techniques will be used to ensure that materials do not fall from heights. Pedestrians will be moved to opposite sides of street from the project site or onto temporary sidewalks such that loads are never suspended above the public realm.
9	Reinstatement of Public Infrastructure & Service Installation	Superstructure	Heavy equipment and hot concrete used during public infrastructure reinstatement and service installation may cause damage to vehicles.	The contractor shall maintain safe distances between vehicles and heavy machinery on-site. Concrete barriers will be installed to separate construction vehicles from public traffic during public infrastructure reinstatement and service installation.	Heavy equipment and hot concrete used during public infrastructure reinstatement may injure pedestrians.	The contractor shall maintain safe distances between pedestrians, vehicles, and heavy machinery.
10	Fallen debris	Superstructure	Debris may fall from upper stories of the new building causing damage to vehicles.	F-Type concrete barriers will be installed such that a safe distance is maintained between the building envelope and vehicular traffic.	Debris may fall from upper stories of the new building injuring pedestrians.	Construction of upper building levels will be set back from the property line/rigid fencing, this separating pedestrians from potential fallen debris.

## Appendix L – Community Consultation Records

---

# COMMUNITY CONSULTATION MAP OVERVIEW

## Project – Herring Cove Development

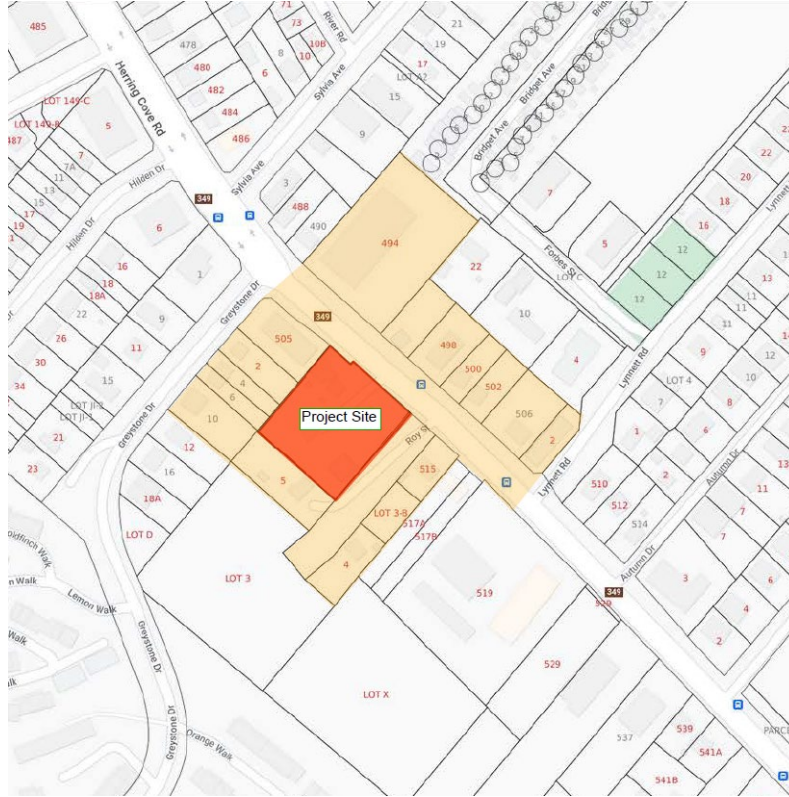

# Notification Letter

Date: \*\*\*\*\*

AMK Barrett Investments Inc. – Building Construction Information Meeting

Dear Neighbour,

As you may be aware, we are planning an apartment building construction project located on Herring Cove Road in Halifax.

If you are interested in receiving more information about our construction plans, practices, schedule and to go over any questions you may have regarding construction of our new project please contact us to discuss. We would be happy to meet with you to discuss.

Thank you.

Adam Barrett

Cell: (902) 877-5560

Email: [adam.barrett@blackbaygroup.ca](mailto:adam.barrett@blackbaygroup.ca)

## Appendix M – HRM Tree Detail

---

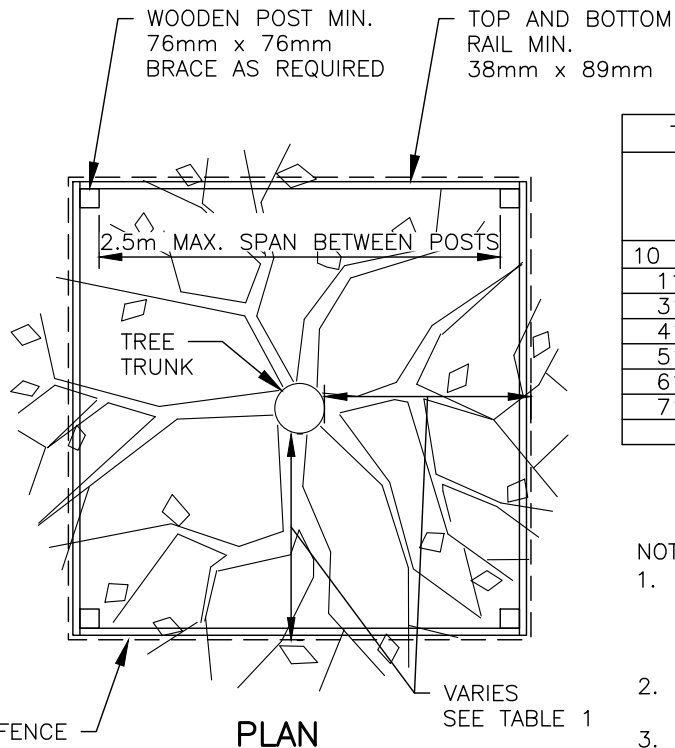

**PLAN**

**TABLE 1**

TREE PROTECTION ZONE CALCULATION TABLE

TRUNK DIAMETER (DBH)	MINIMUM PROTECTION DISTANCE REQUIRED (MEASURE FROM THE OUTSIDE EDGE OF TREE TRUNK)
10 CM & UNDER	1.2 METERS
11 – 30 CM	2.0 METERS
31 – 40 CM	3.4 METERS
41 – 50 CM	4.6 METERS
51 – 60 CM	6.0 METERS
61 – 70 CM	7.0 METERS
71 – 80 CM	8.0 METERS
>80 CM	9.0 METERS

**NOTES:**

1. WOOD POST: (MIN. 76mm WIDTH) INSTALLED TO A DEPTH OF 500mm. TOP AND BOTTOM RAIL: (MIN. 38 x 89mm CONSTRUCTION, MAX. SPAN 2.5m), CROSS BRACING AS REQUIRED.
2. NO GROUND DISTURBANCE WITHIN 1.2 METER OF THE TREE TRUNK (I.E. POST INSTALLATION)
3. POSTS SET BACK FROM SIDEWALK AND CURB: MIN 300mm
4. FENCE MATERIAL: MINIMUM ORANGE BARRIER FENCE OR METAL CHAIN LINK FENCE
5. ATTACH A SIGN ON TWO SIDES OF THE TREE "PROTECTION ZONE DO NOT REMOVE FENCE DURING CONSTRUCTION"

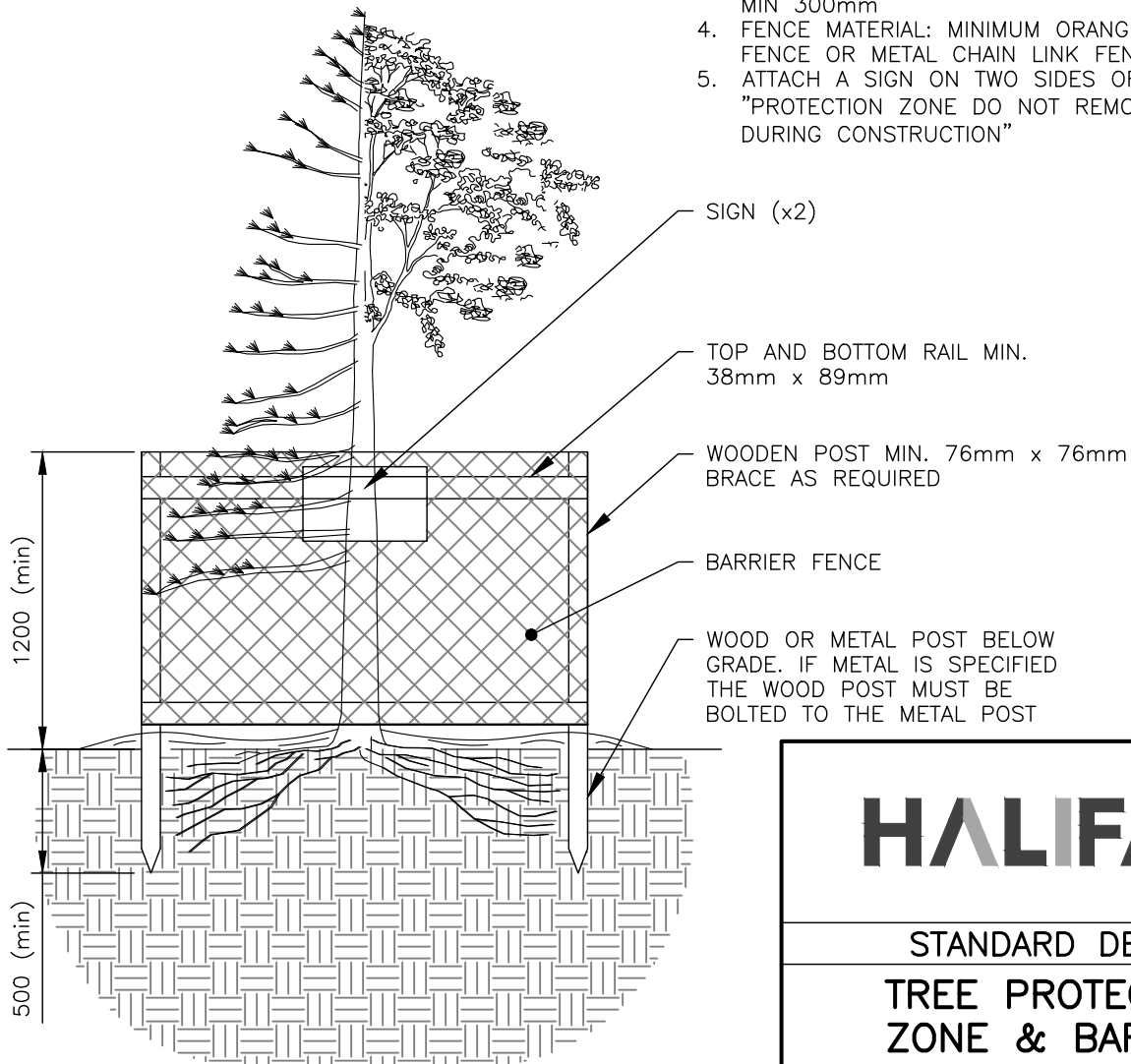

**PROFILE**

# HALIFAX

---

**STANDARD DETAIL**

**TREE PROTECTION ZONE & BARRIER**

DATE:	REFERENCE	APPROVED
2021		
SCALE:		FIG No.:
NTS		HRM 140



## Appendix N – Rodent Control Plan

---

HERRING COVE ROAD  
(WIDTH VARIES)

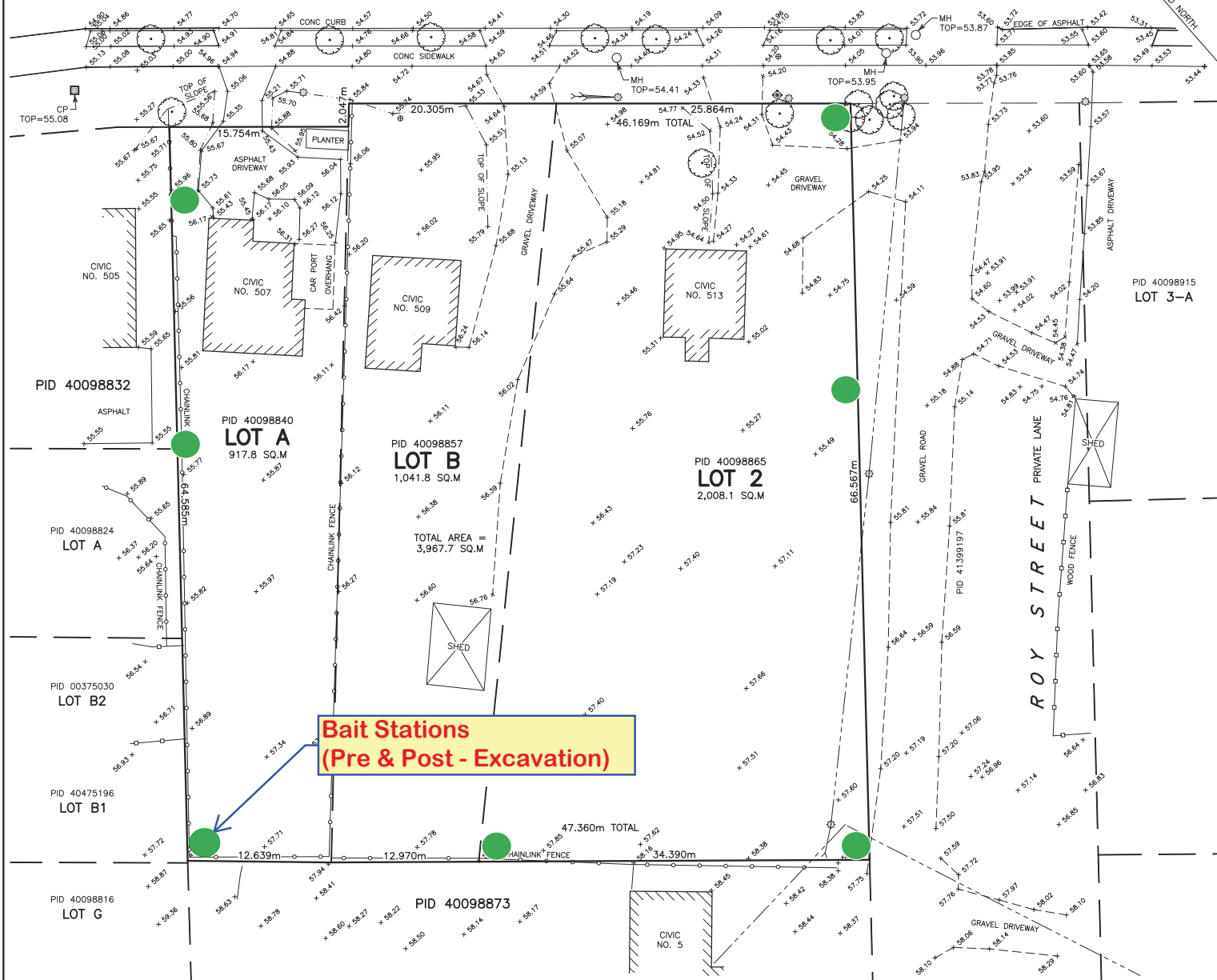

LEGEND

PERIMETER OF LANDS SURVEYED	
x123.4	SPOT ELEVATION
○ MH	MANHOLE
⊠	CATCHBASIN
> CVINV	CULVERT INVERT
⊕ BMF/BMS	BENCHMARK FOUND/SET
⊖	UTILITY POLE & ANCHOR
⊙	LIGHT POLE
⊙	LIGHT STANDARD
⊕	FIRE HYDRANT
⊕	WATER VALVE
⊙	BOLLARD
⊙	SIGN POST
HCLRO	HALIFAX COUNTY LAND REGISTRATION OFFICE
PID	PARCEL IDENTIFICATION NUMBER
CONC	CONCRETE
R/W	RETAINING WALL
O/H	OVERHANG
—○—	CHAINLINK FENCE
—○—	WOOD FENCE
—○—	OVERHEAD WIRES
—○—	TOP OF SLOPE
—○—	TOE OF SLOPE
—○—	CENTRELINE OF DITCH/STREAM
⊙	HARDWOOD TREE
⊙	SOFTWOOD TREE

**Bait Station Legend**  
 Pre & Post Excavation

-  
**Rodent Control Plan**  
 -  
 Prepared for  
**Rentokil Atlantic**  
 -  
**902-835-2304**  
 -  
**51 Duke Street, Bedford, NS**

**Protecta®**  
**EVO®** **AMBUSH™**  
PATENT PENDING



**THE MOST ADVANCED LOW-PROFILE BAIT STATION**

**PRODUCT FEATURES:**

- ▶ Single locking mechanism for quick servicing
- ▶ Removable tray for easy cleaning
- ▶ Locking bait rods won't fall out during cleaning
- ▶ Dog & child tamper-resistant
- ▶ Can hold:
  - 4 - 1 oz. bait BLOX on 4 vertical rods
  - or -
  - T-Rex™ rat trap or Mini-Rex™ mouse trap
- ▶ Compatible with Sidekick® Load-N-Lock™ system



▶ PRODUCT	CODE	DIMENSIONS (in)	CASE QTY
Protecta Evo Ambush	EA2000	8 1/2 x 10 1/4 x 4 1/4	6 Stations



**More Than Meets The Eye**

Madison, Wisconsin 53704 USA | Ph: (608) 241-0202 | Fax: (608) 241-9631

[www.belllabs.com](http://www.belllabs.com)

ALL-WEATHER  
**BLOX™**



**CONTRAC®**  
**ALL-WEATHER BLOX™**

**KILLS RATS, MICE & MEADOW VOLES\***

***Kills Warfarin Resistant Norway Rats***

**KEEP OUT OF REACH OF CHILDREN**

**CAUTION**

See back panels for First Aid and additional precautionary statements.

ACTIVE INGREDIENT:

Bromadiolone (CAS #28772-56-7): . . . . . 0.005%

OTHER INGREDIENTS†: . . . . . 99.995%

†Contains Denatonium Benzoate      TOTAL 100.000%

\*Not permitted for use against the following species in California: Cotton rat, Eastern harvest mouse, Golden mouse, Polynesian rat, Meadow vole, White-throated woodrat, Southern plains woodrat, and Mexican woodrat.

NET WT:  
**18 lbs (8.2 kg)**

#### FIRST AID

##### HAVE LABEL WITH YOU WHEN OBTAINING TREATMENT ADVICE

###### IF SWALLOWED:

- Call a poison control center, doctor, or 1-877-854-2494, or 1-800-858-7378\*\* immediately for treatment advice.
- Have person sip a glass of water if able to swallow.
- Do not induce vomiting unless told to do so by the poison control center or doctor.

###### IF ON SKIN OR CLOTHING:

- Take off contaminated clothing. Rinse skin immediately with plenty of water for 15–20 minutes.
- Call a poison control center or doctor for treatment advice.

###### IF IN EYES:

- Hold eye open and rinse slowly and gently with water for 15–20 minutes.
- Remove contact lenses, if present, after the first 5 minutes, then continue rinsing eye.
- Call a poison control center, doctor, or 1-877-854-2494 immediately for treatment advice.

\*\* Also call this number for information on health concerns and pesticide incidents.

#### NOTE TO PHYSICIAN

If swallowed or absorbed through the skin, this material may reduce the clotting ability of the blood and cause bleeding. If ingested, administer Vitamin K<sub>1</sub> intramuscularly or orally. Repeat as necessary based on monitoring of prothrombin times.

#### TREATMENT FOR PET POISONING

If animal eats bait, call veterinarian at once.

#### NOTE TO VETERINARIAN

**Anticoagulant Bromadiolone:** For animals ingesting bait and/or showing poisoning signs (bleeding or elevated prothrombin times), give Vitamin K<sub>1</sub>. If needed, check prothrombin times every 3 days until values return to normal (up to 30 days). In severe cases, blood transfusions may be needed.

#### DIRECTIONS FOR USE

It is a violation of Federal law to use this product in a manner inconsistent with its labeling.

**READ THIS LABEL:** Read this entire label and follow all use directions and use precautions. Use only for sites, pests, and application methods described on this label.

**IMPORTANT:** Do not expose children, pets, or nontarget animals to rodenticides. To help to prevent exposure:

1. Store unused product out of reach of children and pets.
2. Apply bait in locations out of reach of children, pets, domestic animals and nontarget wildlife, or in tamper-resistant bait stations. These stations must be resistant to destruction by dogs and by children under six years of age, and must be used in a manner that prevents such children from reaching into bait compartments and obtaining bait. If bait can be shaken from bait stations when they are lifted, units must be secured or otherwise immobilized. Stronger bait stations are needed in areas open to hoofed livestock, raccoons, bears, or other potentially destructive animals, or in areas prone to vandalism.
3. Dispose of product container and unused, spoiled, or unconsumed bait as specified on this label.

**Bait stations are mandatory for outdoor, above-ground use. Tamper-resistant bait stations must be used wherever children, pets, non-target mammals, or birds may have access to the bait placement location.**

**USE RESTRICTIONS:** This product may only be used to control the following rodent pests in and around man-made structures: House mouse (*Mus musculus*), Norway rat (*Rattus norvegicus*), Roof rat (*Rattus rattus*), Cotton mouse (*Peromyscus gossypinus*), Cotton rat\* (*Sigmodon hispidus*), Deer mouse (*Peromyscus maniculatus*), Eastern harvest mouse\* (*Reithrodontomys humuli*), Golden mouse\* (*Ochrotomys nuttalli*), Polynesian rat\* (*Rattus exulans*), Meadow vole\* (*Microtus pennsylvanicus*), White-footed mouse (*Peromyscus leucopus*), White-throated woodrat\* (*Neotoma albigula*), Southern plains woodrat\* (*Neotoma micropus*), and Mexican woodrat\* (*Neotoma mexicana*). This product must be used in and within 100 feet of man-made structures constructed in a manner so as to be vulnerable to commensal rodent invasions and/or to harboring or attracting rodent infestations. Examples of such structures include homes and other permanent or temporary residences, food processing facilities, industrial and commercial buildings, trash receptacles, agricultural and public buildings, transport vehicles (ships, trains, aircraft), docks and port or terminal buildings and related structures around and associated with these sites. Fence and perimeter baiting, beyond 100 feet from a structure as defined above, is prohibited. This product must not be applied directly to food or feed crops.

587CB-9

# CONTRAC®

## ALL-WEATHER BLOX™

### KILLS RATS, MICE, AND MEADOW VOLES\*

#### Kills Warfarin Resistant Norway Rats

Norway rats, roof rats, and house mice may consume a lethal dose in one night's feeding with first dead rodents appearing four or five days after feeding begins.

#### ACTIVE INGREDIENT:

Bromadiolone (CAS #28772-56-7): . . . . . 0.005%

OTHER INGREDIENTS: . . . . . 99.995%

†Contains Denatonium Benzoate TOTAL 100.000%

## KEEP OUT OF REACH OF CHILDREN CAUTION

See side panels for First Aid and additional precautionary statements.

#### STORAGE AND DISPOSAL

Do not contaminate water, food or feed by storage or disposal.

**Pesticide Storage:** Store only in original container in a cool, dry place inaccessible to children and pets. Keep containers closed and away from other chemicals.

**Pesticide Disposal:** Wastes resulting from the use of this product may be placed in trash or delivered to an approved waste disposal facility.

**Container Handling:** Nonrefillable container. Do not reuse or refill this container. [Plastic:] Offer for recycling or reconditioning; or puncture and dispose of in a sanitary landfill; or by incineration. In most states, burning is not allowed.

**WARRANTY:** To the extent consistent with applicable law, seller makes no warranty, expressed or implied, concerning the use of this product other than indicated on the label. Buyer assumes all risk of use and/or handling of this material when such use and/or handling is contrary to label instructions.

### NET WEIGHT: 18 lbs (8.2 kg)

EPA REG. NO. 12455-79

EPA EST. NO. 12455-WI-1

Manufactured by:

**Bell**  
LABORATORIES, INC.  
3699 Kinsman Blvd.  
Madison, WI 53704 U.S.A.  
www.bellabs.com  
**MADE IN USA**

#### DIRECTIONS FOR USE (Continued from other panel)

Burrow baiting with Contrac All-Weather Blox is prohibited.

Do not place near or inside ventilation duct openings. Do not contaminate water, food, feedstuffs, food or feed handling equipment, or milk or meat handling equipment or surfaces that come into direct contact with food. When used in USDA inspected facilities, this product must be applied in tamper-resistant bait stations. Do not broadcast bait. Do not use this product in sewers.

Do not sell this product in individual containers holding less than 16 pounds of bait.

**SELECTION OF TREATMENT AREAS:** Determine areas where rats, mice, or meadow voles\* will most likely find and consume the bait. Generally, these areas are along walls, by gnawed openings, in corners and concealed places, between floors and walls, or in locations where rats, mice, or meadow voles\*, or their signs have been seen. Protect bait from rain and snow. Remove as much alternative food as possible.

#### APPLICATION DIRECTIONS:

**RATS:** Place 3 to 16 bait blocks (at intervals of 15 to 30 feet) per placement in infested areas. Maintain an uninterrupted supply of fresh bait for at least 10 days or until signs of rat activity cease.

**MICE AND MEADOW VOLES\*:** Place 1 block per placement. Space placements at 8- to 12-foot intervals in infested areas. Two blocks may be needed at points of very high activity. Maintain an uninterrupted supply of fresh bait for at least 15 days or until signs of mouse or meadow vole\* activity cease.

**FOLLOW-UP:** Replace contaminated or spoiled bait immediately.

Wearing gloves, collect and dispose of all dead, exposed animals and leftover bait. To prevent reinfestation, limit sources of rodent food, water, and harborage as much as possible. If reinfestation does occur, repeat treatment. Where a continuous source of infestation is present, establish permanent bait stations and replenish as needed.

#### PRECAUTIONARY STATEMENTS

##### HAZARDS TO HUMANS AND DOMESTIC ANIMALS

**CAUTION:** Harmful if swallowed or absorbed through the skin. Keep away from children, domestic animals and pets. Do not get in eyes, on skin or on clothing.

All handlers (including applicators) must wear: shoes plus socks, and waterproof gloves. Any person who retrieves carcasses or unused bait following application of this product must wear gloves.

#### User Safety Requirements

Follow manufacturer's instruction for cleaning/maintaining PPE. If no such instructions for washables, use detergent and hot water. Keep and wash PPE separately from other laundry. Remove PPE immediately after handling this product. Wash the outside of gloves before removing. As soon as possible, wash hands thoroughly after applying bait and before eating, drinking, chewing gum, using tobacco or using the toilet and change into clean clothing.

#### ENVIRONMENTAL HAZARDS

This product is extremely toxic to fish, birds and other wildlife. Dogs and predatory and scavenging mammals and birds might be poisoned if they feed upon animals that have eaten this bait. Do not apply this product directly to water or to areas where surface water is present or to intertidal areas below the mean high water mark. Runoff also may be hazardous to aquatic organisms in water adjacent to treated areas. Do not contaminate water when disposing of equipment wash water or rinsate.

\*Not permitted for use against the following species in California: Cotton rat, Eastern harvest mouse, Golden mouse, Polynesian rat, Meadow vole, White-throated woodrat, Southern plains woodrat, and Mexican woodrat.

Product Code: CB4051

090415/09-15





# DETEX<sup>®</sup> BLOX with LUMITRACK

## SAFETY DATA SHEET

ACCORDING TO REGULATION: OSHA  
Hazard Communication Standard 29 CFR 1910.1200

DATE OF ISSUE:  
January 2016

PREPARED BY:  
CAR

### SECTION 1. PRODUCT AND COMPANY IDENTIFICATION

**Product Identifier:** DETEX<sup>®</sup> BLOX with LUMITRACK  
**EPA Registration Number:** NA  
**Relevant identified uses of the substance or mixture and uses advised against**  
**Relevant identified uses:** Activity Monitoring - Ready to use  
**Uses advised against:** Use only for the purpose described above

**MANUFACTURER/SUPPLIER:**

Bell Laboratories, Inc.  
3699 Kinsman Blvd.  
Madison, WI 53704, USA  
Email: sds@belllabs.com  
Phone: 608-241-0202  
Medical or Vet Emergency: 877-854-2494 or 952-852-4636  
Spill or Transportation Emergency: 800-424-9300 (CHEMTREC)

### SECTION 2. HAZARDS IDENTIFICATION

**Classification according to Regulation OSHA 1910.1200(d):** Not classified  
**Signal Word:** None  
See Section 15 for information on FIFRA applicable safety, health, and environmental classifications.

### SECTION 3. COMPOSITION/INFORMATION ON INGREDIENTS

Component	CAS No.	% By weight
<b>Inert and Non-Hazardous Ingredients</b> (Unlisted components are non-hazardous)	Proprietary	100.00%

### SECTION 4. FIRST AID MEASURES

**Description of first aid measures**  
**Ingestion:** Non-Toxic  
**Inhalation:** Not applicable.  
**Eye contact:** Non-Toxic  
**Skin contact:** Non-Toxic  
**Most important symptoms and effects, both acute and delayed**  
Non-Toxic  
**Advice to physician:** Non-Toxic  
**Advice to Veterinarian:** Non-Toxic

### SECTION 5. FIRE-FIGHTING MEASURES

**Extinguishing media**  
Suitable Extinguishing Media: water, foam or inert gas.  
Unsuitable Extinguishing Media: None known.  
**Special hazards arising from the mixture:** High temperature decomposition or burning in air can result in the formation of toxic gases, which may include carbon monoxide.  
**Advice for firefighters:** Wear protective clothing and self-contained breathing apparatus.

### SECTION 6. ACCIDENTAL RELEASE MEASURES

**Personal precautions, protective equipment and emergency procedures:** None. Non-Toxic  
**Environmental precautions:** None. Non-Toxic  
**Methods and materials for containment and cleaning up**  
**For Containment:** None. Non-Toxic  
**For Cleaning Up:** None. Non-Toxic  
**Reference to other sections:** Refer to Sections 7, 8 & 13 for further details of personal precautions, personal protective equipment and disposal considerations.

## SECTION 7. HANDLING AND STORAGE

**Precautions for safe handling:** Do not use near heat sources, open flame, or hot surfaces. Non-Toxic.

**Conditions for safe storage, including any incompatibilities:** None. Non-Toxic

## SECTION 8. EXPOSURE CONTROLS/PERSONAL PROTECTION

### Established Limits

Component	OSHA	ACGIH	Other Limits
None	Not Established	Not Established	Not Established

**Appropriate Engineering Controls:** None. Non-Toxic

**Occupational exposure limits:** None. Non-Toxic

**Personal Protective Equipment:**

**Respiratory protection:** Not required

**Eye protection:** Not required

**Skin protection:** None. Non-Toxic

**Hygiene recommendations:** None. Non-Toxic

## SECTION 9. PHYSICAL AND CHEMICAL PROPERTIES

### Information on basic physical and chemical properties

<b>Appearance/Color:</b>	Tan wax block
<b>Odor:</b>	Sweet grain-like
<b>Odor Threshold:</b>	Not applicable, odor not associated with a hazardous material.
<b>pH:</b>	Not applicable, is not dispersible with water.
<b>Melting point:</b>	Not applicable
<b>Boiling point:</b>	Not applicable
<b>Flash point:</b>	Not applicable, does not contain components classified as flammable.
<b>Evaporation rate:</b>	Not applicable, is a solid.
<b>Flammability:</b>	Not applicable, is a solid.
<b>Upper/lower flammability or explosive limits:</b>	Not applicable, does not contain components classified as flammable or explosive.
<b>Vapor Pressure:</b>	Not applicable
<b>Vapor Density:</b>	Not applicable, is a solid
<b>Relative Density:</b>	1.13 g/mL @ 20°C
<b>Solubility (water):</b>	Not water soluble
<b>Solubility (solvents):</b>	Not applicable
<b>Partition coefficient: n-octanol/water:</b>	Not applicable
<b>Auto-ignition temperature:</b>	Not applicable, does not contain components classified as flammable.
<b>Decomposition temperature:</b>	Not applicable
<b>Viscosity:</b>	Not applicable, is not a liquid.

## SECTION 10. STABILITY AND REACTIVITY

**Reactivity:** Not Applicable

**Chemical stability:** Not Applicable

**Possibility of hazardous reactions:** Refer to Hazardous decomposition products

**Conditions to avoid:** Avoid extreme temperatures (below 0°C or above 40°C).

**Incompatible materials:** Not Applicable

**Hazardous decomposition products:** Not Applicable

## SECTION 11. TOXICOLOGICAL INFORMATION

### Information on toxicological effects

#### Acute Toxicity

**LD50, oral (ingestion):** Not Toxic

**LD50, dermal (skin contact):** Not Toxic

**LC50, inhalation:** Not Toxic

**Skin corrosion/irritation:** Not Toxic

**Serious eye damage/Irritation:** Not Toxic.

**Respiratory or skin sensitization:** Not Toxic

**Germ cell mutagenicity:** Not Toxic

**Carcinogenicity:** Not Toxic

<b>Components</b>	<b>NTP</b>	<b>IARC</b>	<b>OSHA</b>
None	NA	NA	NA

**Reproductive Toxicity:** Not Toxic  
**Aspiration Hazard:** Not Toxic  
**Target Organ Effects:** Not Toxic

## SECTION 12. ECOLOGICAL INFORMATION

**Ecotoxicity Effects:** Not Toxic  
**Persistence and degradability:** Not Toxic  
**Bioaccumulative potential:** Not Toxic  
**Mobility in Soil:** Not Toxic.  
**Other adverse effects:** None.

## SECTION 13. DISPOSAL CONSIDERATIONS

**Disposal:** Wastes resulting from the use of this product may be placed in trash, on-site, or at an approved waste disposal facility. Dispose of all wastes in accordance with all Federal, state and local regulations.

## SECTION 14. TRANSPORT INFORMATION

**UN number:** Not regulated  
**UN proper shipping name:** Not regulated  
**Transport hazard class(es):** Not regulated  
**Packing group :** Not regulated  
**Environmental Hazards**  
**DOT Road/Rail:** Not considered hazardous for transportation via road/rail.  
**DOT Maritime:** Not considered hazardous for transportation by vessel.  
**DOT Air:** Not considered hazardous for transportation by air.  
**Freight Classification:** LTL Class 60  
**Transport in bulk according to Annex II of MARPOL 73/78 and the IBC code:** Not applicable  
**Special precautions for user:** None

## SECTION 15. REGULATORY INFORMATION

**Safety, health and environmental regulations/legislation specific for the substance or mixture:** Not applicable  
**Signal Word:** None  
**Precautionary Statements:** None  
**Potential Health Effects:**  
**Eye Contact:** May cause irritation  
**Skin Contact:** Non-irritating to the skin  
**Ingestion:** Not harmful if swallowed  
  
**TSCA:** All components are listed on the TSCA Inventory or are not subject to TSCA requirements  
**CERCLA/SARA 313:** Not Toxic  
**CERCLA/SARA 302:** Not Toxic

## SECTION 16. OTHER INFORMATION

For additional information, please contact the manufacturer noted in Section 1.

<b>NFPA</b>	Health: 0 (Not Toxic)	Flammability: 1 (slight)	Reactivity: 0 (stable)	Specific Hazard: None
<b>HMIS</b>	Health: 0 (Not Toxic)	Flammability: 1 (slight)	Reactivity: 0 (minimal)	Protective Equipment: None

**Disclaimer:** The information provided in this Safety Data Sheet has been obtained from sources believed to be reliable. Bell Laboratories, Inc. provides no warranties; either expressed or implied, and assumes no responsibility for the accuracy or completeness of the data contained herein. This information is offered for your consideration and investigation. The user is responsible to ensure that they have all current data, including the approved product label, relevant to their particular use.



## Appendix O – CMP’s TCP & PMP Inspection Records

---



## Appendix P – Concrete Delivery Schematic

---

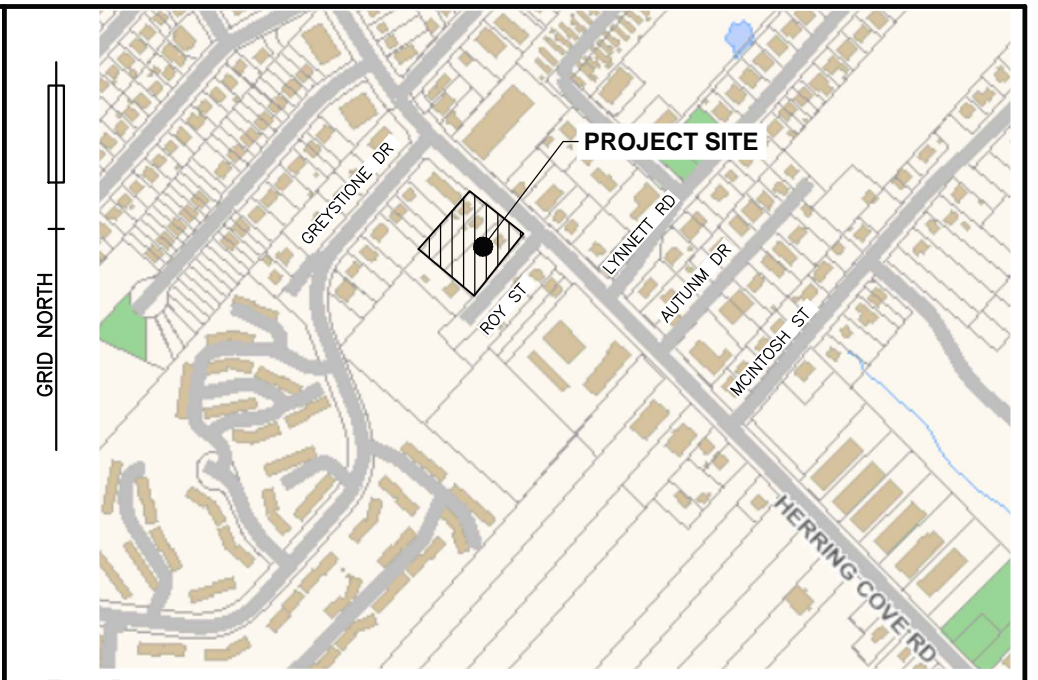
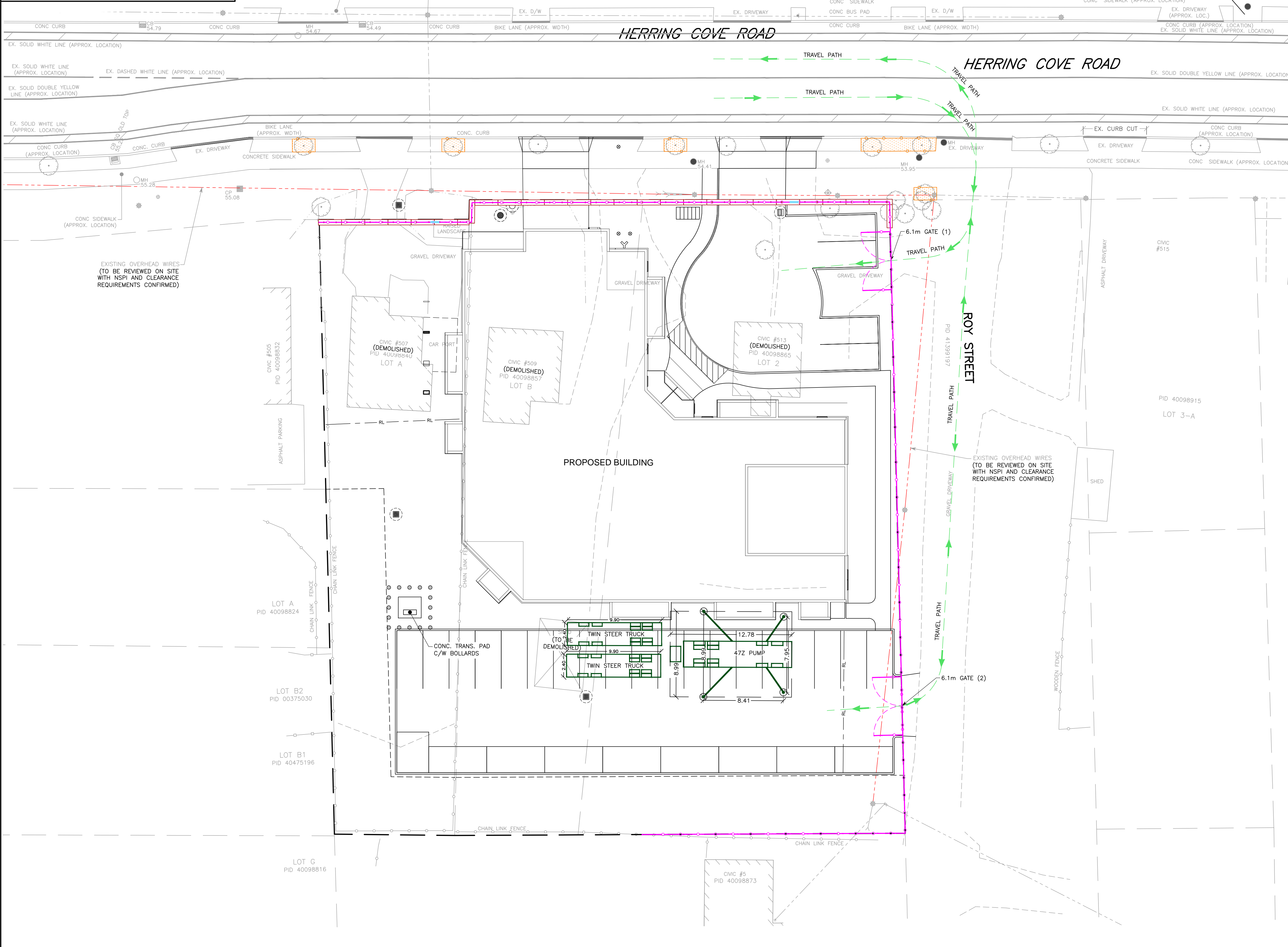
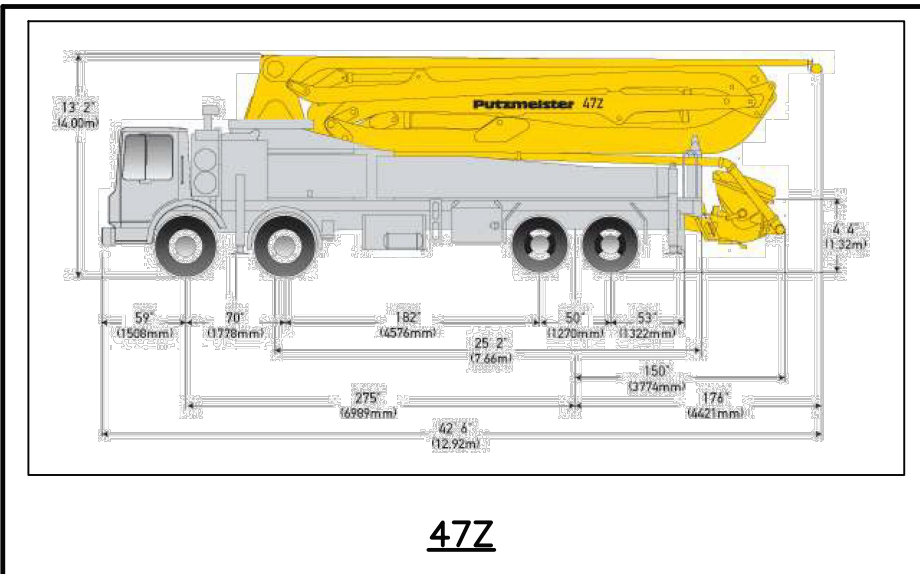

LEGEND

EXISTING	PROPOSED	
25.0	CONTOUR LINE	25.0
⊙/⊙ BF	CURB STOP/GATE/BUTTERFLY VALVE	⊙/⊙ BF
⊙	FIRE HYDRANT	⊙
⊙	CONCRETE THRUST BLOCK	⊙
⊙	SIAMESE CONNECTION	⊙
⊙	CATCH BASIN/PIT	⊙
⊙	CULVERT	⊙
⊙	ROCK LINING/DAM	⊙
⊙	ROCK WALL/RETAINING WALL	⊙
⊙	POWER POLE & ANCHOR/LIGHT STANDARD	⊙
⊙	TREE	⊙
⊙	STREET SIGN/PARKING METER	⊙
× 131.82	ELEVATION/GRADE	125.00 × / 125.00
⊙	TEST PIT	⊙
⊙	DRAINAGE/SWALE FLOW DIRECTION	⊙
W	WATER MAIN/SERVICE	W
SAN	SANITARY MANHOLE & PIPE	SAN
STM	STORM MANHOLE & PIPE	STM
SAV/STM	COMBINED PIPE	SAV/STM
GAS	GAS LINE	GAS
FL	100YR. FLOOD LIMIT	FL
⊙	GUARD RAIL	⊙
⊙	UNDERGROUND CONDUIT	⊙
⊙	OVERHEAD WIRES	⊙
⊙	PROPERTY LINE/BOUNDARY	⊙
⊙	FENCE	⊙
⊙	BUILDING	⊙
⊙	TOP OF SLOPE	⊙
⊙	TOE OF SLOPE	⊙
⊙	TREELINE	⊙
⊙	LIMITS OF DISTURBANCE	⊙
⊙	TACTILE PEDESTRIAN PLATES	⊙
⊙	PROJECT SAFETY SIGNAGE	⊙
⊙	ORANGE SANHORSE BARRICADE	⊙

NOTES

- THIS PLAN IS IN METRIC.
- EXISTING CONDITIONS WITH APPROXIMATE LOCATIONS ARE BASED ON GOOGLE AERIAL IMAGERY AS SITE HAS NOT BEEN FIELD SURVEYED; DIMENSIONS MAY VARY AND SHALL BE CONFIRMED BY CONTRACTOR BEFORE PROCEEDING WITH CONSTRUCTION.

No.	YY/MM/DD	Revision	Description	Appr'd
1	23/09/29	REVISED AS PER HRM & HW COMMENTS		
0	23/06/21	ISSUED FOR REVIEW		

G.K. MacLean  
8978

**SDMM**  
Servant, Dunbrack, McKenzie & MacDonald Ltd.  
NOVA SCOTIA LAND SURVEYORS & CONSULTING ENGINEERS

36 QUINN CRESCENT  
BIRDS LAKE BUSINESS PARK  
HALIFAX, NS B3S 1G6

PHONE: (902) 455-1537  
FAX: (902) 455-9479  
WEB: www.sdmm.ca

**PROPOSED APARTMENT BUILDING**  
507, 509 & 513 HERRING COVE ROAD  
SPRYFIELD, NOVA SCOTIA

CONCRETE DELIVERY SCHEMATIC

Date	Drawn	Project No.
JUNE 21, 2023	D. ANDERSON	FILE NO. 1-2-73 (37051)
Scale	Engineer	Plan No.
1:200	G. MACLEAN	
Reference	Approved	Drawing Name
--	G. MACLEAN	R2
Surveyed	Sheet	
SDMM		

0m 5 10 15 20m