



Montague Estates Lifestyle Living Development

Transportation Impact Study

November 2023

Prepared by:
Fathom Studio
1 Starr Lane
Dartmouth, Nova Scotia
902 461 2525
fathomstudio.ca

Release

Final Report — July 11, 2023
Final Report, Rev. 2 — November 27, 2023



TABLE OF CONTENTS

01	Introduction and Existing Conditions	1	APPENDIX A:	Traffic Counts
1.1	Background and Context	2	APPENDIX B:	Trip Generation
1.2	Roadway Infrastructure	3	APPENDIX C:	Trip Assignment
1.3	Other Transportation Infrastructure	4	APPENDIX D:	Synchro Reports
02	Existing and Future Traffic Conditions	5		
2.1	Existing Traffic	6		
2.2	Traffic Composition	7		
2.3	Project Time Horizons	7		
2.4	Analysis Periods	7		
2.5	Traffic Growth	7		
03	Proposed Development and Analysis	8		
3.1	Proposed Development	9		
3.2	Trip Generation	9		
3.3	Trip Distribution and Assignment	9		
3.4	Transportation Modeling	10		
3.5	Montague Road and New Driveway	11		
3.6	Main Street and Montague Road / Hillsboro Drive	12		
04	Conclusions and Recommendations	13		

01 Introduction and Existing Conditions



1.1 Background and Context

This transportation impact study was prepared to define the anticipated impacts of a proposed development located on PID00624668 on Montague Road about 1.5 kilometers north of Main Street and adjacent to the The Links at Montague Golf Course and Academy in Dartmouth, Nova Scotia. The “Lifestyle Living Project” includes a single 6-storey building with 125-unit lifestyle living units, 56 underground parking spaces and 80 surface parking spaces.

The development is located near the northeast end of the existing driving range and includes a single driveway connecting to Montague Road about 160 meters north of Lake Loon Road on the opposite side of Montague Road, and 400 meters north of Montague Drive on the same side of Montague Road, which provides direct access to the Links at Montague Golf Course and Academy.

The primary study area considered for this report includes:

- Montague Road from the development to the signalized intersection at Main Street and Hillsboro Drive. Beyond this point, traffic volumes generated by the development are low enough that they have virtually no impact on the road network.
- Traffic to the north along Montague Road connects to a variety of short local roadways and to the Exit 14 interchange on the Forest Hills extension about 4.5 kilometers to the north. Again, volumes along this corridor and at the Exit 14 interchange ramp intersections are low enough that detailed analysis is not warranted.



1.2 Roadway Infrastructure

Montague Road

Montague Road is a 2-lane undivided rural roadway with a posted speed limit of 50 kilometers per hour. The road cross section consists of a 7.5 meter paved surface with gravel shoulders that vary in width from about 0.5 to 1.5 meters and includes roadside ditch drainage in most areas. The roadway has many vertical and horizontal curves along its length and has frequent residential driveways servicing single family homes and a number of stop-controlled connections to local residential roadways.



Montague Road facing North



Montague Road facing South

Main Street

Main Street (Route 7) is a major arterial roadway extending from the Circumferential Highway (Highway 111) at its east end and transitions to Highway 107 extending to Musquodoboit Harbour close to 25 kilometers to the east. At Montague Road, Main Street is a 4-lane undivided roadway with dedicated left turn auxiliary lanes on Main Street and a dedicated right turn lane in the eastbound direction from Main Street to Hillsboro Drive.

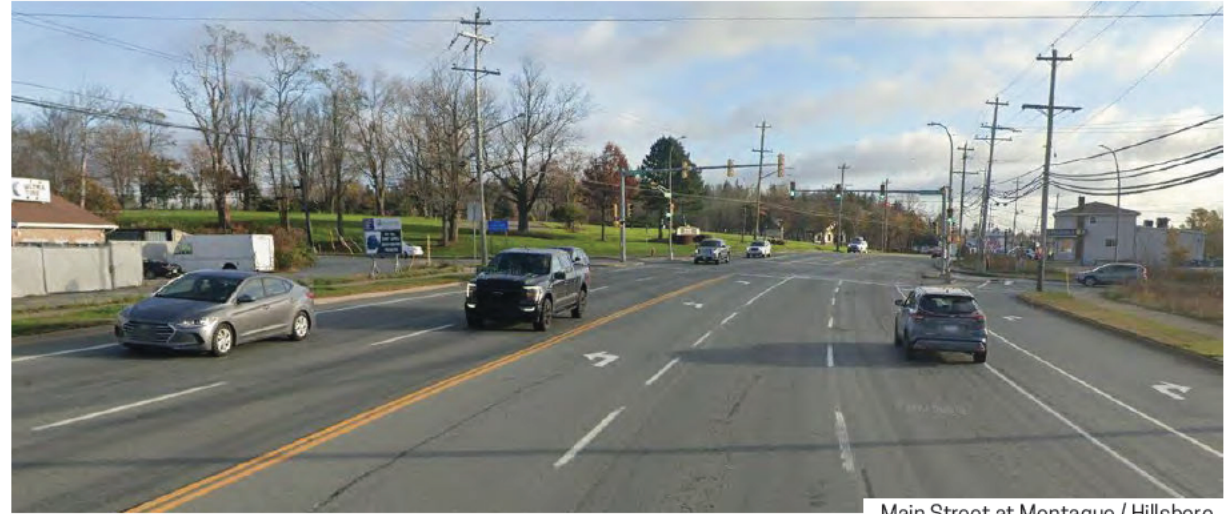

Main Street at Montague / Hillsboro



Main / Montague / Hillsboro Road Intersection

This is a four leg signalized intersection as shown in the figure to the left and includes two through lanes in each direction on Main Street, dedicated left turn lanes from Main Street onto the side roads, a dedicated right turn lane from Main Street to Hillsboro Drive, and right turn channelizations in both directions. Montague Road and Hillsboro Drive have a single lane in each direction, dedicated right turn channelizations, and shared through / left turn lanes. There are signalized pedestrian crosswalks on all four legs of the intersection and painted crosswalks over the right turn channelization lanes.

1.3 Other Transportation Infrastructure

Active Transportation

The HRM active transportation web site shows a variety of existing and future pedestrian and cycling facilities surrounding the project area. Sidewalks are present on Montague Road between Main Street and Lake Loon Road terminating about 150 meters south of the proposed driveway.

The figure to the below left show a variety of existing and future trail networks including the Trans Canada trail network along the southwest side of the Forest Hills Extension / Parkway, new multi-use trail on the east side of the Forest Hills Parkway towards Cole Harbour Place, and other local trails. Yellow lines indicate existing on-road bike lanes currently along much of Main Street, though gaps exist between MacLaughlin / Broom Road and Montague / Hillsboro Drive, as well as between Loonview Lane and Forest Hills. The inset figure below and to the right shows the future intent of AT connectivity through this area including completion of facilities along Main Street past the development.

A variety of other informal trails are also present surrounding the development including routes around the golf course and through the local road network to various parks, playgrounds and recreational areas.

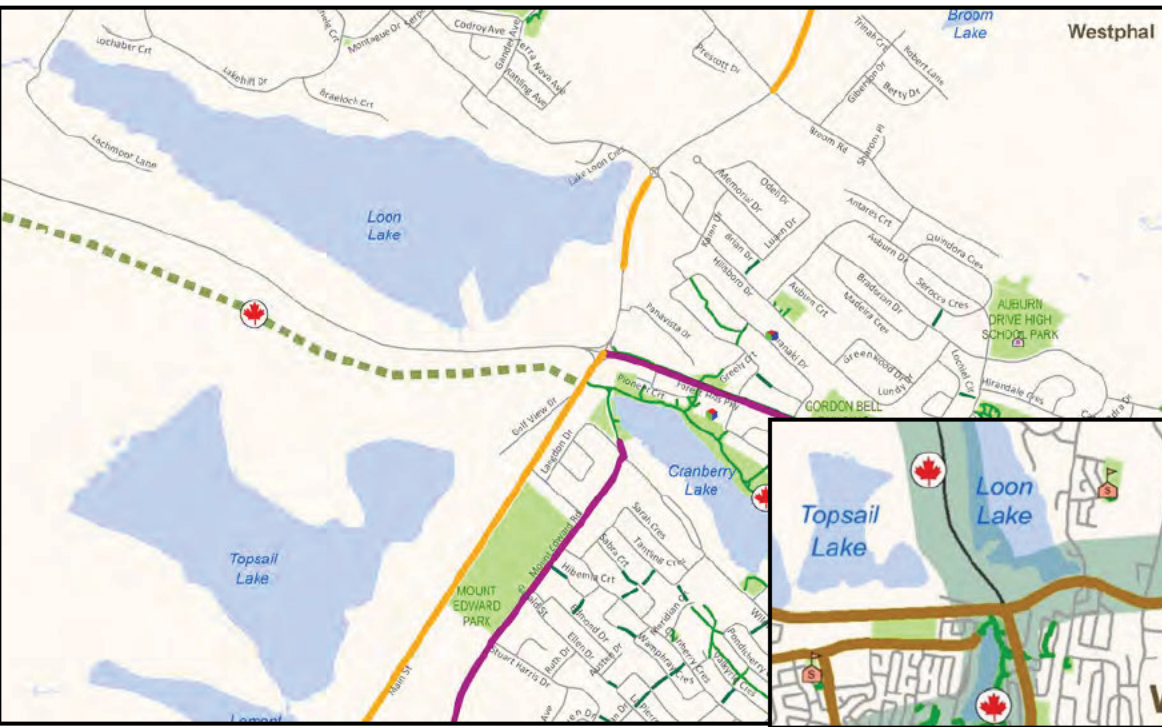

Transit

The latest Halifax Transit routes are shown in the figure above and indicate two primary routes near the development including Route 68 and 168B that loop around Montague Road, Lake Loon Road, Cherry Brook Road and Main Street, ultimately connecting to the Portland Hills Transit terminal. In addition, Routes 61 and 161 connect these routes along Main Street to the Forest Hills Parkway and Lake Major Road to the east.

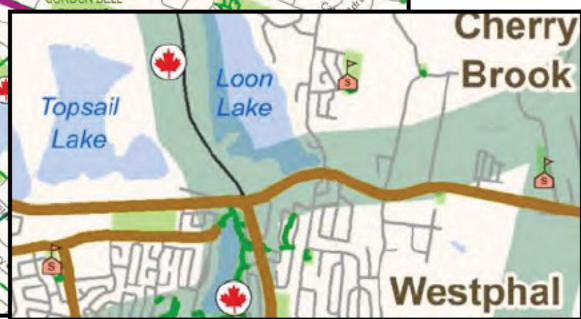

02 Existing and Future Traffic Conditions

2.1 Existing Traffic

Recent traffic count and speed data was obtained from the Halifax Regional Municipality and included data from 2022 and 2023. A supplementary intersection turning movement count was carried out by Fathom Studio at the intersection of Montague Road with Main Street using the Miovision automated traffic counting platform. Data used in this study included:

- Main Street and Montague Road AM and PM peak turning movements counts (Fathom - June 2023);
- Montague Drive and Montague Road AM and PM peak turning movement counts (HRM - April 2023),
- Montague Road speed and volume counts between Serpentine Avenue and Gander Avenue (HRM - May 2022);
- Lakehill Drive speed and volume counts between Lochmoor Lane and Montague Road (HRM - May 2023);

The following key points from the data are relevant to this study:

- Road section counts on Montague Drive in May 2022 near the development show the highest two-way volumes during the AM peak are about 310 vehicles per hour and about 400 during the PM peak hour. Daily volumes ranged from about 2400 to 3200 vehicles per day (vpd).
- 85% vehicle speeds during these same peak periods were about 62 km/h during the AM peak and about 60 km/h during the PM peak. These speeds generally represented the higher average speeds throughout the day.
- Road section counts on Lakehill Drive within the adjacent residential subdivision show daily volumes ranging between 630 and 800 vpd and 85% speeds close to 50kph.
- Volumes at the Main / Montague / Hillsboro intersection show heavy through movements on Main Street with the highest volumes in the typical peak directions (inbound during the AM peak and outbound during the PM peak).
- All other side-road volumes are relatively low with the exception of the westbound right turn from Main to Montague Road during the AM peak and the opposing southbound left turn from Montague to Main Street during the PM peak, which suggests that some drivers are electing to use Montague Road as an alternate route to the Forest Hills Extension through the often congested Main / Forest Hills intersection.

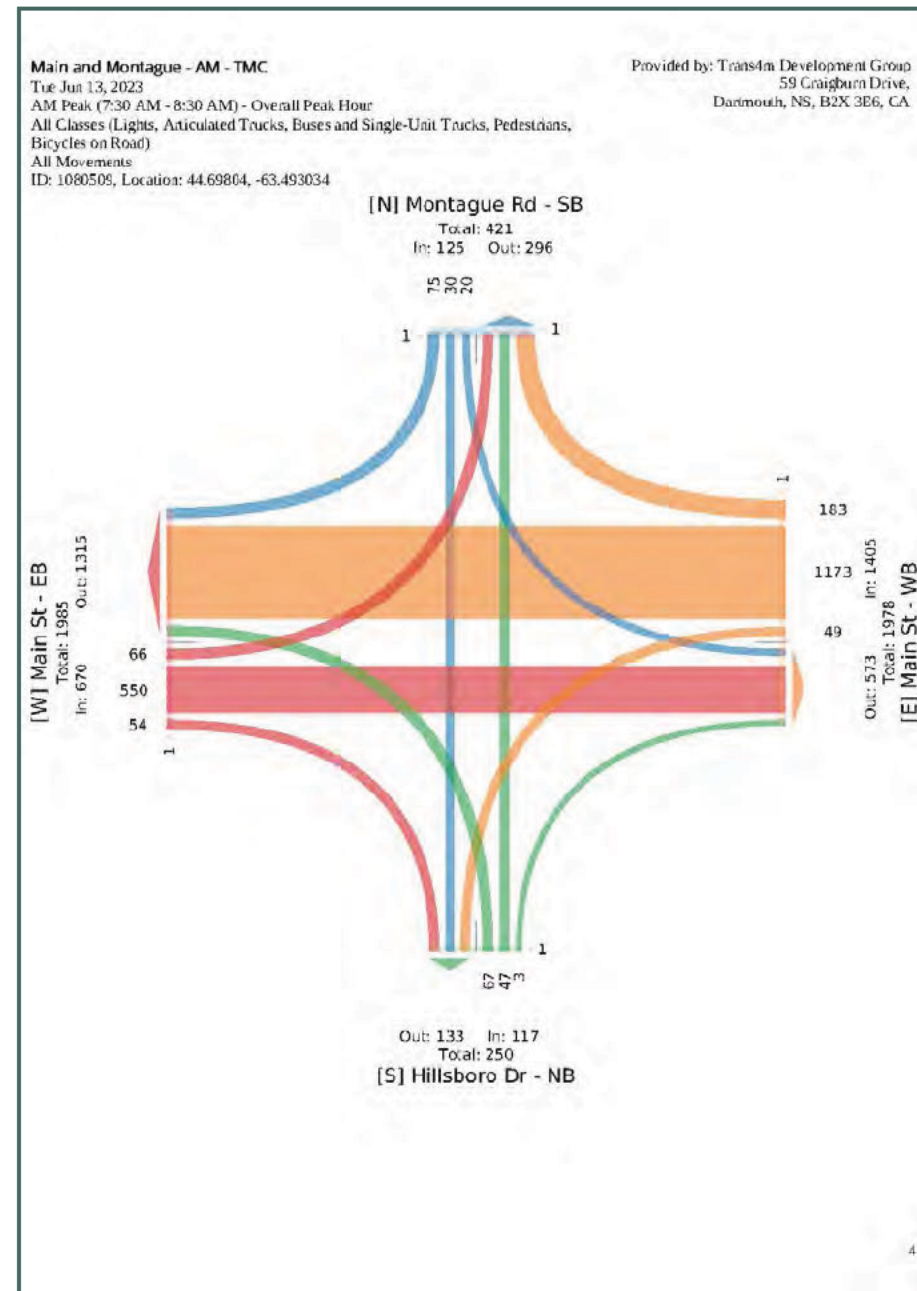

2.2 Traffic Composition

Counts at the Main / Montague / Hillsboro intersection show the following:

- Percentage of articulated trucks are about 1% on Main Street and virtually 0% on Montague and Hillsboro.
- Buses and single unit trucks composed about 4% of total traffic during the AM peak and 2% during the PM peak.
- No bicycles were recorded during the count periods.
- Pedestrian volumes are low with only 5 pedestrians being recorded during the AM peak and 9 pedestrians during the PM peak hour.

2.3 Project Time Horizons

The analysis uses a 2023 baseline traffic scenario based on existing data. It is assumed that the development will be constructed within the next 5 years therefore a 2033, 10-year horizon was used representing a 5-year build-out plus 5 years.

2.4 Analysis Periods

The development is located in a primarily residential neighbourhood with minimal commercial activity. While it is expected that the golf course and other recreational facilities in the area may see some higher trip generation during the weekends, the combination of residential commuter traffic and the use of Montague Road as a commuter thoroughfare suggest that the weekday AM and PM peak periods are the appropriate peak analysis periods.

2.5 Traffic Growth

Estimating future traffic growth has become a more challenging endeavor given a wide variety of impacts that affect travel decisions. Some of these considerations include:

- Timing and extent of recovery from the COVID related impacts to the traffic network, including impacts on transit, AT traffic and vehicle traffic;
- Shifts to alternate modes of travel (both natural and COVID induced) including aggressive initiatives and investment by HRM in AT and transit shifts;
- Increasing opportunities for alternate work arrangements including work from home opportunities, flexible travel arrangements and location options;
- Wider area traffic growth stemming from aggressive provincial growth initiatives;
- Technology shifts toward electric automobile and self-driving vehicles;
- Future road improvements including the potential for the Cherry Brook Connector.

For the purposes of this study, a reasonably aggressive 2% annual growth rate has been applied over the 10 year time horizon as this development is not expected to impact the adjacent road network in any meaningful way.

03 Proposed Development and Analysis

MONTAGUE DEVELOPMENT PLAN

Scale = 1:1250

0 25 50m

November 2023



3.1 Proposed Development

The proposed development includes 125 lifestyle living units within a 6-storey building. There are 56 underground parking stalls and 80 surface parking spaces arranged in an L-formation adjacent to the building with access to the underground parkade proposed at the east end of the building. The main driveway connects to Montague Road at a 90 degree angle and is proposed to include a single entry and exit lane (2 lane cross section) with a sidewalk along the south and west sides of the driveway.

3.2 Trip Generation

New trips generated by the development were estimated based on the Institute of Transportation Engineers (ITE) Trip Generation Guide (11th Edition). The trip generation table below shows the anticipated new trips to and from the road network for a 125-unit lifestyle living complex. Due to the nature of the development and proposed land uses, peak hour trip generation rates are relatively low as compared to regular residential apartments or condominiums.

Land Use	Trip Code	# Units	Variable	AM Peak			PM Peak		
				Enter	Exit	TOTAL	Enter	Exit	TOTAL
Lifestyle Living Facility	254	125	Units	14	9	23	12	18	30

Transit and Active Transportation Impacts

Due to the nature of lifestyle living facilities, there is likely to be limited use of local active transportation and transit services during the peak hours of adjacent roadway traffic. Therefore no adjustments have been made to the trip generation rates to account for modal share distributions.

3.3 Trip Distribution and Assignment

Trips to and from the proposed site were distributed in a manner that represents the most likely travel directions for visitors and staff travel to and from the development. In general, this followed patterns of major residential development surrounding the development area and access to major transportation corridors.

The figure below shows the distribution assumptions used in this report, though variations in these distribution assumptions are expected to have little impact on the analysis results due to the low volumes of traffic generated by the development.

Given the simplicity of the connected road network, assignment of trips to the network is a straight forward process and not addressed further in this report.



3.4 Transportation Modeling

A detailed traffic model was prepared using the Synchro/SimTraffic (v.11) platform for the weekday AM and PM peak hours of analysis. The model was used to gain insight into operations and capacity utilization at the various intersections directly impacted by the proposed development under each of the traffic loading scenarios. The analysis included the following models for each of the AM and PM peak hours:

- 2023 Baseline conditions,
- 2033 future conditions with background and development traffic.

The results of the modeling exercise are summarized by individual intersection for both the AM and PM peak hours. Results are shown in tabular format to allow for the quick comparison of key performance measures between the different analysis scenarios. All sections include supporting text that highlights key considerations at the intersection and connecting roadways. Key performance indicators used in this report include:

- Peak hour volumes (vehicles / hour) by intersection turning movement,
- Volume to capacity ratios (V/C) by movement,
- Average Delay (sec/vehicle), and
- 95% Queue lengths.

The summary figures and tables are followed by a brief discussion of the results for each peak period at each intersection highlighting key findings. Additional details are provided in the Synchro reports provided in Appendix D of this report.



3.5 Montague Road and New Driveway

The new driveway to the proposed development is configured with single lane entry and exit lanes and connect to Montague Road at approximately a 90° angle. The tables to the right show that the intersection operates at a very high level of service under future traffic conditions with 2% annual background growth over 10-years plus the addition of development traffic. Average delays per vehicle are about 10 seconds during the AM and PM peak hours with volume to capacity ratios of less than 0.15 (15% of theoretical capacity) during the AM peak and 0.25 during the PM peak for all movements. There is no notable queuing on the developments driveway or on Montague Road during the peak hours.

The analysis suggests that the intersection can be constructed with basic stop control on the new driveway and free flow conditions maintained on Montague Road. Volumes are low enough for existing through and turning movement volumes that a dedicated left turn lane is not warranted on Montague Road. Further, left and right turn volume into the development are low enough that there is very limited impact to through vehicles on Montague Road.

Sight Distances

The new driveway is located on a relative flat and straight section of Montague Road allowing good sight distances in each direction from the driveway (intersection sight distance) and on Montague Road (stopping / decision sight distance). The critical intersection sight distances were evaluated based on guidance proceeded in the Transportation Association of Canada’s Geometric Design Guide. The evaluation assumed a design speed of 70 k/h on Montague Road based on the recent speed studies showing 85% speeds just over 60 km/h despite the posted speed of 50 km/h. The required and available sight distances are show in the table below.

<i>Sigh Distances</i>	Required by TAC	Available
Northbound from Driveway	130 m	~ 200 m
Southbound from Driveway	150 m	> 300 m

The table shows that sight distances can be met in both directions on Montague Road, through will require the removal of vegetation adjacent to the driveway to ensure adequate sightlines are maintained.

AM PEAK		New Driveway EB		Montague NB		Montague SB	
		Left	Right	Left	Thru	Thru	Right
2023 Baseline	Vol veh/hr	0	0	0	250	170	0
	V/C Ratio	0.00		0.00		0.11	
	Delay sec/v	-		-		-	
	95% Q m	-		-		-	
2033 Development	Vol veh/hr	2	10	16	305	207	4
	V/C Ratio	0.02		0.01		0.13	
	Delay sec/v	10.0		0.5		0.0	
	95% Q m	0.4		0.3		0.0	

PM PEAK		New Driveway EB		Montague NB		Montague SB	
		Left	Right	Left	Thru	Thru	Right
2023 Baseline	Vol veh/hr	0	0	0	130	320	0
	V/C Ratio	0.00		0.00		0.20	
	Delay sec/v	-		-		-	
	95% Q m	-		-		-	
2033 Development	Vol veh/hr	5	20	12	158	390	4
	V/C Ratio	0.05		0.01		0.25	
	Delay sec/v	11.5		0.7		0.0	
	95% Q m	1.2		0.3		0.0	



Northbound from New Driveway



Southbound from New Driveway

3.6 Main Street and Montague Road / Hillsboro Drive

Volumes at the Main Street / Montague Road / Hillsboro Drive signalized intersection are significant given that Main Street is a major east/west commuter corridor. The volumes show heavy peak directional movements in the eastbound and westbound directions and typically operate with volume to capacity ratios around 0.75 - 0.80 under existing conditions.

Levels of service remain good through the peak hours as the majority of green time can be attributed to the main through movements on Main Street with limited need for dedicated left turn phases for most movements. During the PM peak hour, the southbound left turn movements experiences higher volumes which require a dedicated left turn movement, though can function at good levels of service due to minimal opposing volumes on Hillsboro Drive.

Under 2033 conditions with 2% annual growth and development traffic added to the road network, volume to capacity ratios increase to about 0.95 though reasonable levels of delay and queue accumulation can be maintained due to limited competition for traffic signal green time. This higher level of capacity utilization is almost exclusively related to the growth in background traffic as development related traffic composes only 32 vehicles of a total of 3864 vehicles through the intersection (PM peak hour), or about 0.8% of total traffic through the intersection.

AM PEAK		Main Street EB			Main Street WB			Hillsboro Drive NB			Montague Road SB		
		Left	Thru	Rght	Left	Thru	Rght	Left	Thru	Rght	Left	Thru	Rght
2023 Baseline	Vol <i>veh/hr</i>	70	560	60	55	1200	190	70	50	5	25	35	80
	V/C Ratio	0.33	0.31	0.07	0.13	0.78		0.39			0.34		
	Delay <i>sec/v</i>	9.4	10.6	2.0	6.1	17.9		30.2			16.1		
	95% Q <i>veh</i>	8.4	37.2	4.3	7.3	125.2		35.6			26.4		
2032 Development	Vol <i>veh/hr</i>	93	683	73	67	1463	238	85	63	6	34	44	102
	V/C Ratio	0.44	0.38	0.09	0.18	0.95		0.55			0.44		
	Delay <i>sec/v</i>	13.8	11.2	2.5	6.6	30.7		35.4			20.0		
	95% Q <i>veh</i>	14.4	46.4	5.8	8.5	207.3		44.9			36.6		

PM PEAK		Main Street EB			Main Street WB			Hillsboro Drive NB			Montague Road SB		
		Left	Thru	Rght	Left	Thru	Rght	Left	Thru	Rght	Left	Thru	Rght
2023 Baseline	Vol <i>veh/hr</i>	125	1480	165	35	800	35	70	30	15	220	80	90
	V/C Ratio	0.40	0.74	0.17	0.44	0.56		0.33		0.03	0.76		0.18
	Delay <i>sec/v</i>	12.9	16.1	1.9	39.9	19.2		24.9		0.1	38.5		10.1
	95% Q <i>veh</i>	19.6	136	8.3	19.8	84.0		28.1		0.0	82.3		15.0
2032 Development	Vol <i>veh/hr</i>	158	1804	201	43	975	48	85	38	18	275	100	119
	V/C Ratio	0.66	0.94	0.22	0.57	0.72		0.46		0.03	0.89		0.21
	Delay <i>sec/v</i>	27.5	29.5	2.6	52.1	24.2		28.8		0.1	50.9		12.3
	95% Q <i>veh</i>	37.4	223	11.4	24.8	110.1		36.7		0.0	124.7		20.7

04 Conclusions and Recommendations



This study was prepared to evaluate the impacts on the surrounding transportation network, of the proposed 125 unit 'Lifestyle Living' project located between Montague Road and The Links at Montague Golf Course and Academy in Dartmouth, Nova Scotia. The development includes access to 80 above ground parking stalls adjacent to the building and 56 underground parking spaces accessed from a parkade ramp near the southeast corner of the building.

The development is located in a primarily low density residential area and is reasonably separated from adjacent residences including treed buffers. The driveway connects to Montague Road at a location that provides adequate sight distances and has minimal impact to adjacent properties. Care should be taken to coordinate the driveway with the opposing residential driveway across Montague Road and some vegetation will need to be cleared to provide adequate sightlines from the driveway along Montague Road.

The analysis contained in this report show that the development contributes very little traffic to the adjacent road network. At the proposed driveway with Montague Road, low volumes from the development and relatively low volumes on Montague Road result in a stop controlled driveway operating at a very high level of service for the foreseeable future. The driveway can be configured with single lane entry and exit points, and no upgrades are required along Montague Road in order to accommodate the development.

South of the development, traffic moves through the Main Street intersection with Montague Road and Hillsboro Drive. Development traffic contributes about 0.8% of the total traffic through the intersection and therefore has negligible impacts on operations at this intersection. No improvements are required to this intersection or connecting roadways to accommodate the proposed development.

To the north of the development, traffic accesses the Exit 14 ramp intersections with the Forest Hills Extension. Again, volumes are low enough that they have negligible impact on operations at these intersections.

The development has reasonably close access to both transit service and active transportation infrastructure located at the intersection of Montague Road with Lake Loon Road about 150 m south of the proposed development driveway. There are a number of local options for active transportation access, including pathways around the golf course and along the local low volume road network that can provide access to these facilities.

We trust that this report satisfies the Halifax Regional Municipality's requirements for the preparation of a development Transportation Impact Study. Should there be any questions or comments regarding the content of the study, please do not hesitate to contact the undersigned.

Roger Boychuk • P Eng • Senior Transportation Engineer
www.fathomstudio.ca (formerly Ekistics Planning & Design and Form:Media)
1 Starr Lane, Dartmouth, NS B2Y 4V7
902.233.1152 [mobile]
Roger.Boychuk@FathomStudio.ca [email]

APPENDIX A

TRAFFIC COUNTS

MANUAL TRAFFIC COUNTS

INTERSECTION: MAIN ST AT MONTAGUE RD & HILLSBORO DR WEATHER OVERCAST
 DAY DATE MONTH YEAR RECORDER JACOB COSMAN & SAM CRIMP
THURS 22 AUGUST 2019

STREET: TIME: 15 MIN INTERVALS	MAIN ST			MAIN ST			MONTAGUE RD			HILLSBORO DR			TOTAL
	FROM THE EAST			FROM THE WEST			FROM THE NORTH			FROM THE SOUTH			
	L	S	R	L	S	R	L	S	R	L	S	R	
07:00:00 AM 07:15:00 AM	1	333	10	7	71	2	0	1	15	23	7	1	471
07:15:00 AM 07:30:00 AM	9	326	19	10	81	8	1	4	13	37	9	3	520
07:30:00 AM 07:45:00 AM	7	338	47	14	88	8	1	4	7	35	14	3	566
07:45:00 AM 08:00:00 AM	4	324	35	15	107	15	4	1	20	28	13	2	568
TOTAL	21	1321	111	46	347	33	6	10	55	123	43	9	2125
PEAK		1453			426			71			175		
4(15 MIN PEAK)		1568			548			100			208		
PEAK HOUR FACTOR		0.93			0.78			0.71			0.84		
TWO WAY TOTALS		1815			1925			271			239		
													AAWT FACTOR
													0.98
													2083

STREET: TIME: 15 MIN INTERVALS	MAIN ST			MAIN ST			MONTAGUE RD			HILLSBORO DR			TOTAL
	FROM THE EAST			FROM THE WEST			FROM THE NORTH			FROM THE SOUTH			
	L	S	R	L	S	R	L	S	R	L	S	R	
08:00:00 AM 08:15:00 AM	3	274	16	13	101	10	6	4	19	44	10	4	504
08:15:00 AM 08:30:00 AM	4	342	8	11	145	12	3	0	8	25	1	5	564
08:30:00 AM 08:45:00 AM	3	274	8	11	102	10	3	3	12	41	4	1	472
08:45:00 AM 09:00:00 AM	4	252	11	17	131	12	3	0	14	24	4	5	477
TOTAL	14	1142	43	52	479	44	15	7	53	134	19	15	2017
PEAK		1199			575			75			168		
4(15 MIN PEAK)		1416			672			116			232		
PEAK HOUR FACTOR		0.85			0.86			0.65			0.72		
TWO WAY TOTALS		1708			1904			189			233		
													AAWT FACTOR
													0.98
													1977

Intersection Peak Hour

07:30 - 08:30		MAIN ST			MAIN ST			MONTAGUE RD			HILLSBORO DR			Total
		Left	Thru	Right	Left	Thru	Right	Left	Thru	Right	Left	Thru	Right	
	Car	15	1234	105	52	398	45	14	8	54	130	36	12	2103
	Truck	3	44	1	1	43	0	0	1	0	2	2	2	99
	Bicycle	0	0	0	0	0	0	0	0	0	0	0	0	0
	Vehicle Total	18	1278	106	53	441	45	14	9	54	132	38	14	2202
	Approach Factor	0.93			0.86			0.65			0.84			FACTOR
														1
														2202

Peak Hour Pedestrians

07:30 - 08:30		NE			NW			SW			SE			Total	
		Left	Right	Total	Left	Right	Total	Left	Right	Total	Left	Right	Total		
	Pedestrians	0	0	0	0	1	0	0	0	1	0	0	0	0	1

Car traffic

Interval starts	MAIN ST			MAIN ST			MONTAGUE RD			HILLSBORO DR			Total
	Left	Thru	Right	Left	Thru	Right	Left	Thru	Right	Left	Thru	Right	
7:00	1	327	10	6	64	2	0	1	15	23	7	1	457
7:15	8	319	19	10	69	8	1	4	11	37	9	2	497
7:30	6	327	46	14	84	8	1	4	7	34	14	3	548
7:45	4	306	35	15	95	15	4	1	20	28	12	1	536
8:00	2	268	16	13	92	10	6	3	19	44	9	4	486
8:15	3	333	8	10	127	12	3	0	8	24	1	4	533
8:30	2	266	8	11	93	10	3	3	12	41	4	1	454
8:45	4	242	11	17	127	12	3	0	14	24	4	4	462
TOTAL	30	2388	153	96	751	77	21	16	106	255	60	20	3973

Truck traffic

Interval starts	MAIN ST			MAIN ST			MONTAGUE RD			HILLSBORO DR			Total
	Left	Thru	Right	Left	Thru	Right	Left	Thru	Right	Left	Thru	Right	
7:00	0	6	0	0	1	7	0	0	0	0	0	0	14
7:15	1	7	0	0	12	0	0	0	2	0	0	1	23
7:30	1	11	1	0	4	0	0	0	0	1	0	0	18
7:45	0	18	0	0	12	0	0	0	0	0	1	1	32
8:00	1	6	0	0	9	0	0	1	0	0	1	0	18
8:15	1	9	0	1	18	0	0	0	1	0	1	1	31
8:30	1	8	0	0	9	0	0	0	0	0	0	0	18
8:45	0	10	0	0	4	0	0	0	0	0	0	1	15
TOTAL	5	75	1	2	75	0	0	1	2	2	2	4	169

Bicycle traffic

Interval starts	MAIN ST			MAIN ST			MONTAGUE RD			HILLSBORO DR			Total
	Left	Thru	Right	Left	Thru	Right	Left	Thru	Right	Left	Thru	Right	
7:00	0	0	0	0	0	0	0	0	0	0	0	0	0
7:15	0	0	0	0	1	1	0	0	0	0	0	0	1
7:30	0	0	0	0	0	0	0	0	0	0	0	0	0
7:45	0	0	0	0	0	0	0	0	0	0	0	0	0
8:00	0	0	0	0	0	0	0	0	0	0	0	0	0
8:15	0	0	0	0	0	0	0	0	0	0	0	0	0
8:30	0	0	0	0	0	0	0	0	0	0	0	0	0
8:45	0	0	0	0	0	0	0	0	0	0	0	0	0
TOTAL	0	0	0	0	0	0	0	0	1	0	0	0	1

Pedestrian volumes

Interval starts	NE			NW			SW			SE			Total
	Left	Right	Total	Left	Right	Total	Left	Right	Total	Left	Right	Total	
7:00	0	0	0	0	0	0	0	0	0	0	0	0	0
7:15	0	0	0	0	1	1	0	0	0	0	0	0	1
7:30	0	0	0	0	1	1	0	0	0	0	0	0	1
7:45	0	0	0	0	0	0	0	0	0	0	0	0	0
8:00	0	0	0	0	0	0	0	0	0	0	0	0	0
8:15	0	0	0	0	0	0	0	0	0	0	0	0	0
8:30	0	0	0	0	0	0	0	0	0	0	0	0	0
8:45	0	0	0	0	0	0	1	0	1	0	0	0	1
TOTAL	0	0	0	0	2	2	1	0	1	0	0	0	3

VEHICULAR GRAPHIC SUMMARY SHEET

MAIN ST AT MONTAGUE RD & HILLSBORO DR

DATE: THURS AUGUST 22 2019
 FROM: 07:00 AM TO 08:00 AM

FACTORED TOTAL INTERSECTION APPROACH VOLUME 2083

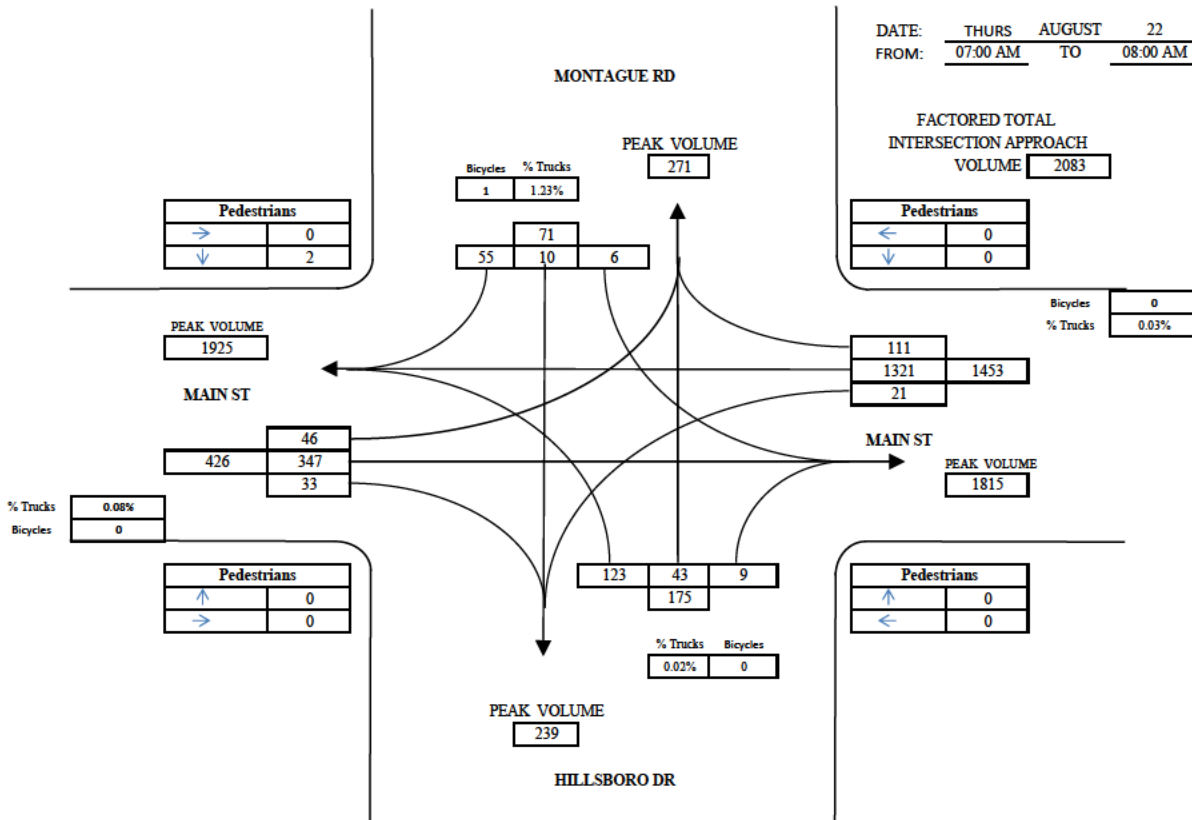

DATE: THURS AUGUST 22 2019
 FROM: 08:00 AM TO 09:00 AM

FACTORED TOTAL INTERSECTION APPROACH VOLUME 1977

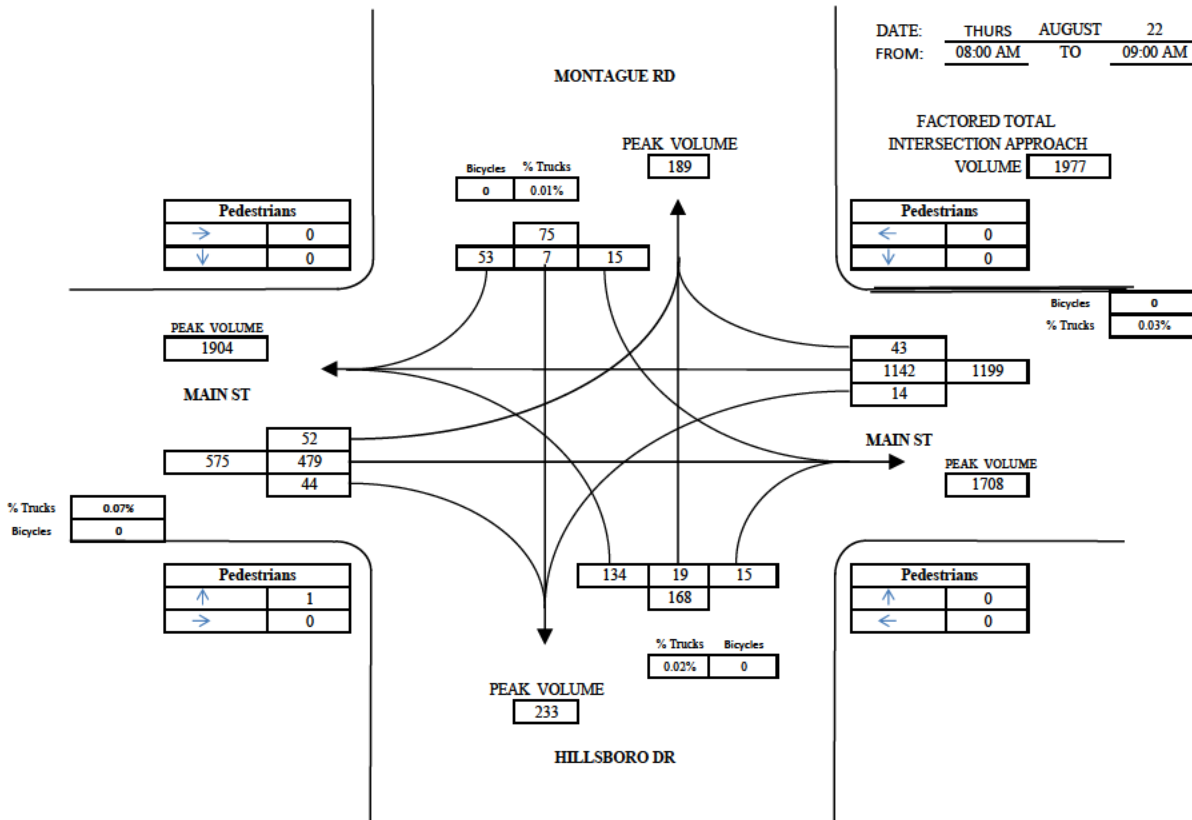

MANUAL TRAFFIC COUNTS

INTERSECTION:

MAIN ST AT MONTAGUE RD & HILLSBORO DR

WEATHER

SUNNY

DAY DATE MONTH YEAR
THURS 22 AUGUST 2019

RECORDER JACOB COSMAN & SAM CRIMP

STREET:

TIME: 15 MIN INTERVALS	MAIN ST			MAIN ST			MONTAGUE RD			HILLSBORO DR			TOTAL
	FROM THE EAST L S R	FROM THE WEST L S R	FROM THE NORTH L S R	FROM THE SOUTH L S R									
04:00:00 PM 04:15:00 PM	5 165 7	18 441 65	7 6 15	21 7 6	763								
04:15:00 PM 04:30:00 PM	8 179 9	26 447 45	30 16 17	26 7 10	820								
04:30:00 PM 04:45:00 PM	9 168 8	18 455 48	39 17 22	30 5 3	822								
04:45:00 PM 05:00:00 PM	9 166 6	25 444 61	24 16 33	26 9 8	827								

TOTAL	31 678 30 87 1787 219 100 55 87 103 28 27 3232
PEAK	739 2093 242 158
4(15 MIN PEAK)	784 2120 312 172
PEAK HOUR FACTOR	0.94 0.99 0.78 0.92
TWO WAY TOTALS	2653 2961 387 463
AAWT FACTOR	0.98
	3167

DAY DATE MONTH YEAR
THURS 22 AUGUST 2019

TIME: 15 MIN INTERVALS	FROM THE EAST			FROM THE WEST			FROM THE NORTH			FROM THE SOUTH			TOTAL
	L S R	L S R	L S R	L S R									
05:00:00 PM 05:15:00 PM	5 191 3	31 463 70	40 23 15	25 4 7	877								
05:15:00 PM 05:30:00 PM	8 174 2	24 424 64	34 24 20	33 6 6	819								
05:30:00 PM 05:45:00 PM	8 182 7	25 404 61	41 22 28	15 3 4	800								
05:45:00 PM 06:00:00 PM	13 150 5	29 380 38	19 7 20	36 11 5	713								

TOTAL	34 697 17 109 1671 233 134 76 83 109 24 22 3209
PEAK	748 2013 293 155
4(15 MIN PEAK)	796 2296 364 208
PEAK HOUR FACTOR	0.94 0.89 0.8 0.75
TWO WAY TOTALS	2575 2902 443 498
AAWT FACTOR	0.98
	3145

Intersection Peak Hour

	MAIN ST			MAIN ST			MONTAGUE RD			HILLSBORO DR			Total
	Left	Thru	Right	Left	Thru	Right	Left	Thru	Right	Left	Thru	Right	
16:15 -17:15	27	678	26	100	1773	223	133	72	86	106	23	26	3273
Car	4	26	0	0	36	1	0	0	1	1	2	2	73
Truck	0	0	0	0	0	0	0	0	0	0	0	0	0
Bicycle	0	0	0	0	0	0	0	0	0	0	0	0	0
Vehicle Total	31	704	26	100	1809	224	133	72	87	107	25	28	3346
Approach Factor	0.96			0.94			0.98			0.93			FACTOR
													1
													3346

Peak Hour Pedestrians

16:15 -17:15	NE			NW			SW			SE			Total
	Left	Right	Total	Left	Right	Total	Left	Right	Total	Left	Right	Total	
Pedestrians	0	0	0	0	0	0	0	0	0	1	0	0	1

Car traffic

Interval starts	MAIN ST			MAIN ST			MONTAGUE RD			HILLSBORO DR			Total
	Left	Thru	Right	Left	Thru	Right	Left	Thru	Right	Left	Thru	Right	
16:00	4	155	6	18	431	65	7	5	14	21	6	6	738
16:15	7	173	9	26	437	45	30	16	17	25	6	9	800
16:30	8	160	8	18	446	47	39	17	21	30	5	3	802
16:45	7	159	6	25	433	61	24	16	33	26	8	8	806
17:00	5	186	3	31	457	70	40	23	15	25	4	6	865
17:15	7	166	2	23	416	64	32	24	19	33	6	6	798
17:30	7	177	7	24	393	61	41	22	28	15	3	3	781
17:45	13	142	5	29	376	37	19	7	20	36	10	5	699
TOTAL	58	1318	46	194	3389	450	232	130	167	211	48	46	6289

Truck traffic

Interval starts	MAIN ST			MAIN ST			MONTAGUE RD			HILLSBORO DR			Total
	Left	Thru	Right	Left	Thru	Right	Left	Thru	Right	Left	Thru	Right	
16:00	1	10	1	0	10	0	0	1	1	0	1	0	25
16:15	1	6	0	0	10	0	0	0	1	1	1	1	20
16:30	1	8	0	0	9	1	0	0	1	0	0	0	20
16:45	2	7	0	0	11	0	0	0	0	0	1	0	21
17:00	0	5	0	0	6	0	0	0	0	0	0	1	12
17:15	1	8	0	1	8	0	2	0	1	0	0	0	21
17:30	1	5	0	1	11	0	0	0	0	0	0	1	19
17:45	0	8	0	0	4	1	0	0	0	0	1	0	14
TOTAL	7	57	1	2	69	2	2	1	3	1	4	3	152

Bicycle traffic

Interval starts	MAIN ST			MAIN ST			MONTAGUE RD			HILLSBORO DR			Total
	Left	Thru	Right	Left	Thru	Right	Left	Thru	Right	Left	Thru	Right	
16:00	0	0	0	0	0	0	0	0	0	0	0	1	1
16:15	0	0	0	0	0	0	0	0	0	0	0	0	0
16:30	0	0	0	0	0	0	0	0	0	0	0	0	0
16:45	0	0	0	0	0	0	0	0	0	0	0	0	0
17:00	0	0	0	0	0	0	0	0	0	0	0	0	0
17:15	0	0	0	0	0	0	0	0	0	0	0	0	0
17:30	0	0	0	0	0	0	0	0	0	0	1	0	1
17:45	0	0	0	0	0	0	0	0	0	0	0	0	0
TOTAL	0	0	0	0	0	0	0	0	0	0	1	1	2

Pedestrian volumes

Interval starts	NE			NW			SW			SE			Total
	Left	Right	Total	Left	Right	Total	Left	Right	Total	Left	Right	Total	
16:00	0	0	0	0	0	0	0	0	3	3	0	0	3
16:15	0	0	0	0	0	0	0	0	0	0	0	0	0
16:30	0	0	0	0	0	0	0	0	0	0	1	0	1
16:45	0	0	0	0	0	0	0	0	0	0	0	0	0
17:00	0	0	0	0	0	0	0	0	0	0	0	0	0
17:15	0	0	0	0	0	0	0	0	0	0	0	0	0
17:30	0	0	0	0	0	0	0	0	0	0	0	0	0
17:45	0	0	0	0	0	0	0	0	0	3	0	3	3
TOTAL	0	0	0	0	0	0	0	3	3	4	0	4	7

VEHICULAR GRAPHIC SUMMARY SHEET

MAIN ST AT MONTAGUE RD & HILLSBORO DR

DATE: THURS AUGUST 22 2019
 FROM: 04:00 PM TO 05:00 PM

FACTORED TOTAL INTERSECTION APPROACH VOLUME 3167

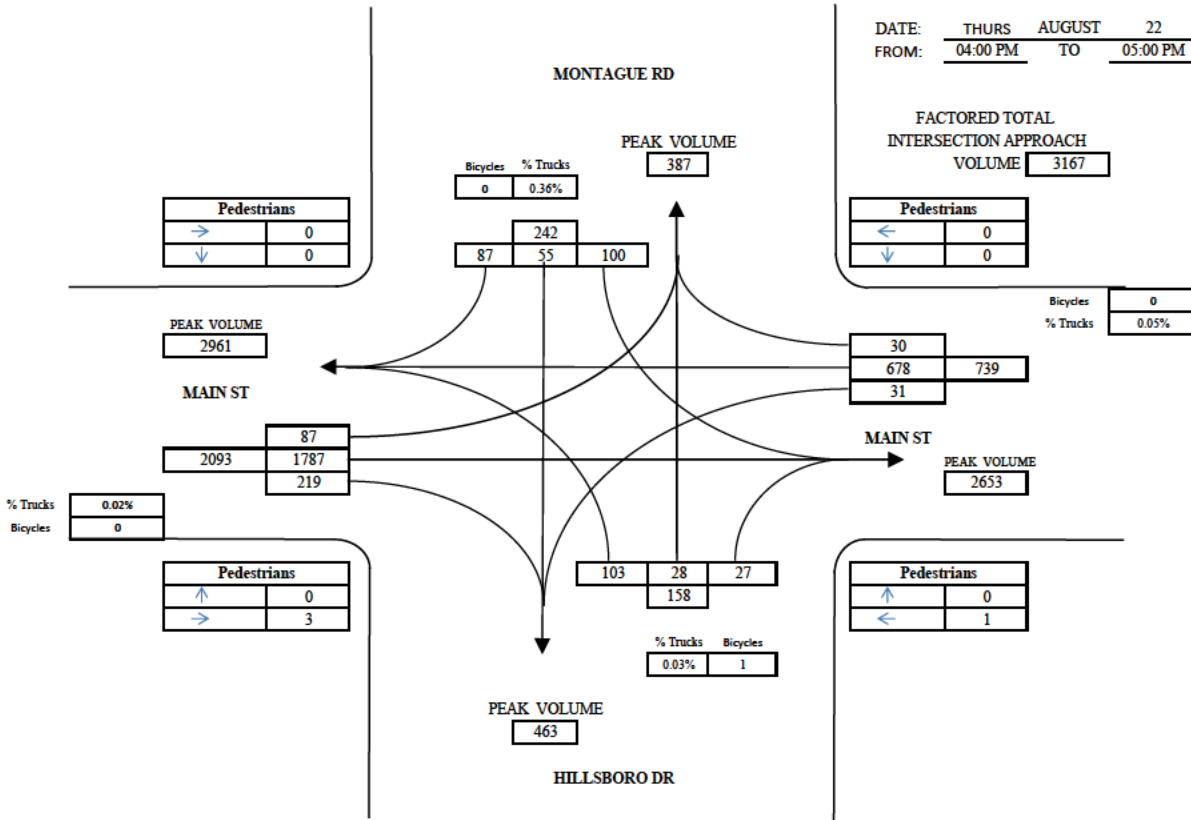

DATE: THURS AUGUST 22 2019
 FROM: 05:00 PM TO 06:00 PM

FACTORED TOTAL INTERSECTION APPROACH VOLUME 3145

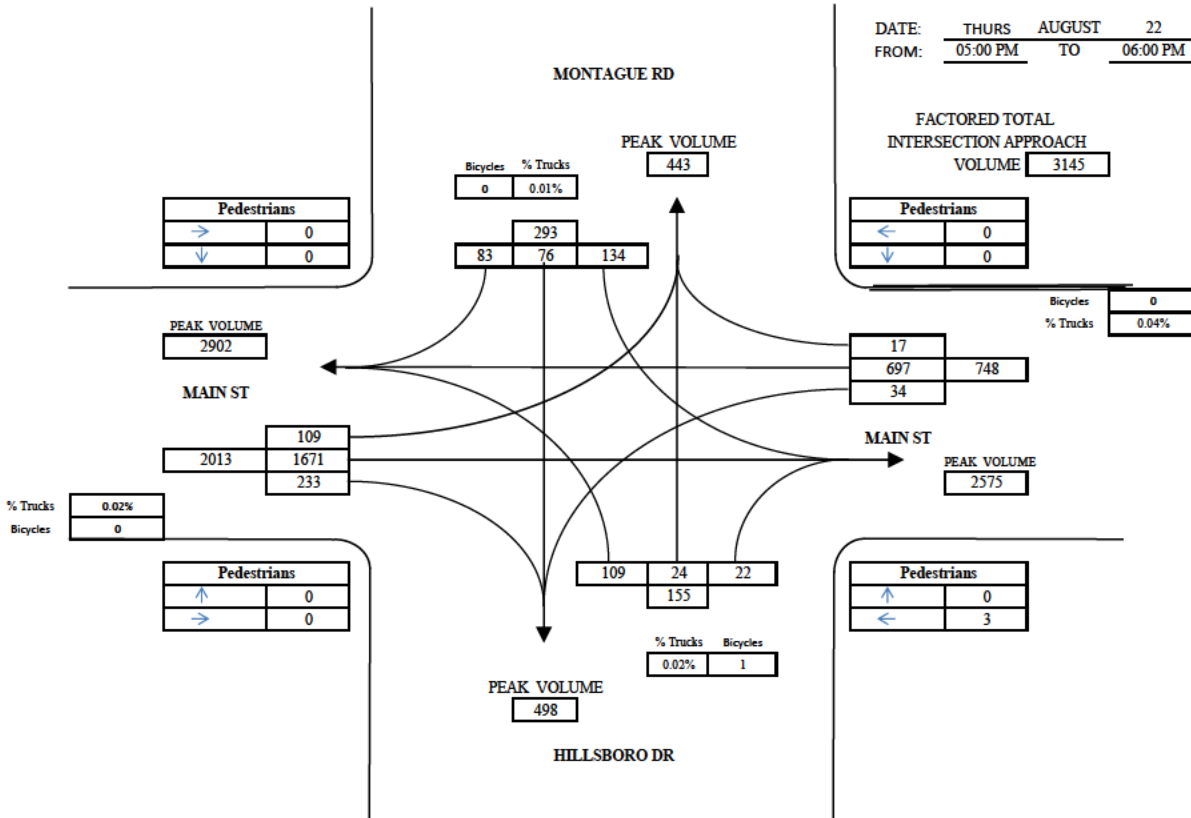

Merged Weekly Counts

22RQ197

from Mon-May-16-2022-12-00-PM to Wed-May-25-2022-10-59-AM

Montague Rd between Serpentine Ave and Gander Ave. Regular orientation. Mounted in front of civic 209. Incoming traffic travelling northbound.

AWT: 2635

	5/16/2022	to	5/22/2022							
	Monday	Tuesday	Wednesday	Thursday	Friday	Saturday	Sunday	Week	Weekend	Week Day 85%
Hour	5/16/2022	5/17/2022	5/18/2022	5/19/2022	5/20/2022	5/21/2022	5/22/2022	Day Avg	Avg	Avg Speed
0 - 1	*	2	8	16	8	8	9	8.5	8.5	59
1 - 2	*	7	4	3	1	4	8	3.75	6	57.75
2 - 3	*	4	2	2	0	8	6	2	7	51.33
3 - 4	*	3	2	2	5	4	2	3	3	61.25
4 - 5	*	1	1	3	5	3	3	2.5	3	46.75
5 - 6	*	24	24	29	35	4	4	28	4	60.68
6 - 7	*	84	80	109	66	21	6	84.75	13.5	61.22
7 - 8	*	223	262	309	195	42	31	247.25	36.5	62.25
8 - 9	*	127	200	242	151	76	47	180	61.5	59.7
9 - 10	*	78	126	129	111	128	69	111	98.5	57.48
10 - 11	*	73	125	138	144	166	127	120	146.5	59.88
11 - 12	*	77	139	136	171	142	127	130.75	134.5	58.12
12 - 13	41	93	140	161	194	182	135	125.8	158.5	58.8
13 - 14	137	126	170	175	186	170	164	158.8	167	59.04
14 - 15	174	150	209	178	187	168	174	179.6	171	58.84
15 - 16	153	145	205	191	227	178	157	184.2	167.5	59.28
16 - 17	292	286	340	358	319	137	143	319	140	58.18
17 - 18	334	353	426	398	260	135	122	354.2	128.5	58.98
18 - 19	139	144	160	202	156	119	80	160.2	99.5	59.9
19 - 20	99	121	124	161	130	109	84	127	96.5	59.46
20 - 21	124	136	135	118	77	57	70	118	63.5	57.76
21 - 22	63	83	68	79	71	53	45	72.8	49	58.06
22 - 23	16	28	25	36	40	30	34	29	32	59
23 - 24	9	5	10	15	27	14	18	13.2	16	57.14
Totals	1581	2373	2985	3190	2766	1958	1665			
% of Total	9.57%	14.37%	18.07%	19.31%	16.75%	11.85%	10.08%			

Hour	5/23/2022	to	5/29/2022					Week	Weekend	Week Day 85%
	Monday 5/23/2022	Tuesday 5/24/2022	Wednesday 5/25/2022	Thursday 5/26/2022	Friday 5/27/2022	Saturday 5/28/2022	Sunday 5/29/2022	Day Avg	Avg	Avg Speed
0 - 1	8	2	4	*	*	*	*	4.67	0	52
1 - 2	2	6	4	*	*	*	*	4	0	55.33
2 - 3	1	1	3	*	*	*	*	1.67	0	48
3 - 4	3	1	1	*	*	*	*	1.67	0	51.67
4 - 5	1	2	5	*	*	*	*	2.67	0	59
5 - 6	7	32	25	*	*	*	*	21.33	0	60.67
6 - 7	22	88	118	*	*	*	*	76	0	63.27
7 - 8	30	287	316	*	*	*	*	211	0	61.93
8 - 9	45	156	207	*	*	*	*	136	0	59.7
9 - 10	79	120	131	*	*	*	*	110	0	58.07
10 - 11	97	124	40	*	*	*	*	87	0	56.93
11 - 12	140	131	*	*	*	*	*	135.5	0	58.9
12 - 13	153	154	*	*	*	*	*	153.5	0	58.15
13 - 14	143	156	*	*	*	*	*	149.5	0	57.95
14 - 15	185	167	*	*	*	*	*	176	0	57.8
15 - 16	178	208	*	*	*	*	*	193	0	57.75
16 - 17	170	317	*	*	*	*	*	243.5	0	59.5
17 - 18	183	374	*	*	*	*	*	278.5	0	59.3
18 - 19	117	144	*	*	*	*	*	130.5	0	59.5
19 - 20	88	114	*	*	*	*	*	101	0	61
20 - 21	112	123	*	*	*	*	*	117.5	0	57.95
21 - 22	51	71	*	*	*	*	*	61	0	58.25
22 - 23	29	24	*	*	*	*	*	26.5	0	58.5
23 - 24	15	15	*	*	*	*	*	15	0	59.5
Totals	1859	2817	854	0	0	0	0			
% of Total	33.62%	50.94%	15.44%	0%	0%	0%	0%			

Northbound Weekly Counts

22RQ197

from Mon-May-16-2022-12-00-PM to Wed-May-25-2022-10-59-AM

Montague Rd between Serpentine Ave and Gander Ave. Regular orientation. Mounted in front of civic 209. Incoming traffic travelling northbound.

AWT: 1099

Hour	5/16/2022	to	5/22/2022	Thursday	Friday	Saturday	Sunday	Week	Weekend	Week Day 85%
	Monday	Tuesday	Wednesday							
	5/16/2022	5/17/2022	5/18/2022	5/19/2022	5/20/2022	5/21/2022	5/22/2022	Day Avg	Avg	Avg Speed
0 - 1	*	0	1	7	3	2	5	2.75	3.5	58.9
1 - 2	*	3	2	2	0	3	2	1.75	2.5	61
2 - 3	*	2	1	1	0	3	2	1	2.5	50
3 - 4	*	0	1	0	2	2	1	0.75	1.5	62
4 - 5	*	1	0	1	4	2	1	1.5	1.5	52
5 - 6	*	7	5	10	15	2	1	9.25	1.5	57.5
6 - 7	*	47	52	83	42	8	0	56	4	62.12
7 - 8	*	143	186	217	118	14	12	166	13	63.02
8 - 9	*	48	107	151	74	35	16	95	25.5	60.6
9 - 10	*	34	53	60	49	67	24	49	45.5	56.88
10 - 11	*	24	59	59	50	63	56	48	59.5	60.75
11 - 12	*	38	67	62	75	66	58	60.5	62	59.5
12 - 13	18	36	61	69	87	80	59	54.2	69.5	60.2
13 - 14	56	51	60	82	71	73	60	64	66.5	59.94
14 - 15	69	62	81	78	75	79	78	73	78.5	59.28
15 - 16	63	67	79	83	74	62	66	73.2	64	59.86
16 - 17	81	77	74	82	92	68	54	81.2	61	59.94
17 - 18	97	101	116	104	69	49	52	97.4	50.5	60.12
18 - 19	59	53	65	83	54	40	29	62.8	34.5	60.78
19 - 20	39	46	50	69	66	44	28	54	36	59.32
20 - 21	39	53	48	47	35	23	37	44.4	30	59.7
21 - 22	26	36	37	23	42	26	22	32.8	24	58.8
22 - 23	7	14	12	17	13	16	18	12.6	17	56.8
23 - 24	5	3	7	7	12	6	5	6.8	5.5	57.6
Totals	559	946	1224	1397	1122	833	686			
% of Total	8.26%	13.98%	18.09%	20.64%	16.58%	12.31%	10.14%			

Hour	5/23/2022	to	5/29/2022					Week	Weekend	Week Day 85%
	Monday 5/23/2022	Tuesday 5/24/2022	Wednesday 5/25/2022	Thursday 5/26/2022	Friday 5/27/2022	Saturday 5/28/2022	Sunday 5/29/2022	Day Avg	Avg	Avg Speed
0 - 1	2	2	3	*	*	*	*	2.33	0	53.33
1 - 2	0	3	1	*	*	*	*	1.33	0	62
2 - 3	1	0	2	*	*	*	*	1	0	50
3 - 4	2	0	1	*	*	*	*	1	0	51.5
4 - 5	1	1	1	*	*	*	*	1	0	59
5 - 6	2	10	9	*	*	*	*	7	0	59
6 - 7	11	58	85	*	*	*	*	51.33	0	61.77
7 - 8	9	213	234	*	*	*	*	152	0	61
8 - 9	25	78	119	*	*	*	*	74	0	59.6
9 - 10	34	60	65	*	*	*	*	53	0	58.17
10 - 11	43	66	21	*	*	*	*	43.33	0	57.1
11 - 12	63	58	*	*	*	*	*	60.5	0	59.75
12 - 13	66	59	*	*	*	*	*	62.5	0	58.35
13 - 14	61	66	*	*	*	*	*	63.5	0	57.45
14 - 15	87	50	*	*	*	*	*	68.5	0	57.65
15 - 16	79	77	*	*	*	*	*	78	0	57.35
16 - 17	65	85	*	*	*	*	*	75	0	61.05
17 - 18	96	102	*	*	*	*	*	99	0	59.05
18 - 19	47	55	*	*	*	*	*	51	0	60.15
19 - 20	37	39	*	*	*	*	*	38	0	60.75
20 - 21	32	38	*	*	*	*	*	35	0	59.5
21 - 22	21	26	*	*	*	*	*	23.5	0	56.85
22 - 23	14	14	*	*	*	*	*	14	0	58
23 - 24	8	5	*	*	*	*	*	6.5	0	56.25
Totals	806	1165	541	0	0	0	0			
% of Total	32.09%	46.38%	21.54%	0%	0%	0%	0%			

Southbound Weekly Counts

22RQ197

from Mon-May-16-2022-12-00-PM to Wed-May-25-2022-10-59-AM

Montague Rd between Serpentine Ave and Gander Ave. Regular orientation. Mounted in front of civic 209. Incoming traffic travelling northbound.

AWT: 1536

	5/16/2022	to	5/22/2022							
	Monday	Tuesday	Wednesday	Thursday	Friday	Saturday	Sunday	Week	Weekend	Week Day 85%
Hour	5/16/2022	5/17/2022	5/18/2022	5/19/2022	5/20/2022	5/21/2022	5/22/2022	Day Avg	Avg	Avg Speed
0 - 1	*	2	7	9	5	6	4	5.75	5	58
1 - 2	*	4	2	1	1	1	6	2	3.5	55.75
2 - 3	*	2	1	1	0	5	4	1	4.5	50
3 - 4	*	3	1	2	3	2	1	2.25	1.5	59.25
4 - 5	*	0	1	2	1	1	2	1	1.5	41
5 - 6	*	17	19	19	20	2	3	18.75	2.5	60.42
6 - 7	*	37	28	26	24	13	6	28.75	9.5	58.88
7 - 8	*	80	76	92	77	28	19	81.25	23.5	60.15
8 - 9	*	79	93	91	77	41	31	85	36	58.58
9 - 10	*	44	73	69	62	61	45	62	53	58.18
10 - 11	*	49	66	79	94	103	71	72	87	59.1
11 - 12	*	39	72	74	96	76	69	70.25	72.5	56.75
12 - 13	23	57	79	92	107	102	76	71.6	89	57.04
13 - 14	81	75	110	93	115	97	104	94.8	100.5	58.64
14 - 15	105	88	128	100	112	89	96	106.6	92.5	58.22
15 - 16	90	78	126	108	153	116	91	111	103.5	58.5
16 - 17	211	209	266	276	227	69	89	237.8	79	57.7
17 - 18	237	252	310	294	191	86	70	256.8	78	58.6
18 - 19	80	91	95	119	102	79	51	97.4	65	59.46
19 - 20	60	75	74	92	64	65	56	73	60.5	59.28
20 - 21	85	83	87	71	42	34	33	73.6	33.5	56.06
21 - 22	37	47	31	56	29	27	23	40	25	57.22
22 - 23	9	14	13	19	27	14	16	16.4	15	59
23 - 24	4	2	3	8	15	8	13	6.4	10.5	58.8
Totals	1022	1427	1761	1793	1644	1125	979			
% of Total	10.48%	14.63%	18.06%	18.39%	16.86%	11.54%	10.04%			

Hour	5/23/2022	to	5/29/2022					Week	Weekend	Week Day 85%
	Monday 5/23/2022	Tuesday 5/24/2022	Wednesday 5/25/2022	Thursday 5/26/2022	Friday 5/27/2022	Saturday 5/28/2022	Sunday 5/29/2022	Day Avg	Avg	Avg Speed
0 - 1	6	0	1	*	*	*	*	2.33	0	52.5
1 - 2	2	3	3	*	*	*	*	2.67	0	59.67
2 - 3	0	1	1	*	*	*	*	0.67	0	50.5
3 - 4	1	1	0	*	*	*	*	0.67	0	52
4 - 5	0	1	4	*	*	*	*	1.67	0	44
5 - 6	5	22	16	*	*	*	*	14.33	0	60.33
6 - 7	11	30	33	*	*	*	*	24.67	0	60
7 - 8	21	74	82	*	*	*	*	59	0	62.67
8 - 9	20	78	88	*	*	*	*	62	0	61
9 - 10	45	60	66	*	*	*	*	57	0	57.73
10 - 11	54	58	19	*	*	*	*	43.67	0	57.1
11 - 12	77	73	*	*	*	*	*	75	0	57.35
12 - 13	87	95	*	*	*	*	*	91	0	57.7
13 - 14	82	90	*	*	*	*	*	86	0	58
14 - 15	98	117	*	*	*	*	*	107.5	0	57.65
15 - 16	99	131	*	*	*	*	*	115	0	58.15
16 - 17	105	232	*	*	*	*	*	168.5	0	58.6
17 - 18	87	272	*	*	*	*	*	179.5	0	59.2
18 - 19	70	89	*	*	*	*	*	79.5	0	59.75
19 - 20	51	75	*	*	*	*	*	63	0	60.4
20 - 21	80	85	*	*	*	*	*	82.5	0	57.35
21 - 22	30	45	*	*	*	*	*	37.5	0	58.65
22 - 23	15	10	*	*	*	*	*	12.5	0	57.5
23 - 24	7	10	*	*	*	*	*	8.5	0	58.5
Totals	1053	1652	313	0	0	0	0			
% of Total	34.89%	54.74%	10.37%	0%	0%	0%	0%			

Halifax Regional Municipality (Dartmouth, NS)
PO Box 1749

Halifax, Nova Scotia, Canada B3J 3A5
(902) 490-4866

Count Name: 23RQ354
Site Code: Montague Dr and Montague Rd
Start Date: 04/04/2023
Page No: 1

Turning Movement Data

Start Time	Montague Rd Southbound					Montague Dr Northbound					Montague Rd Eastbound					Int. Total
	Right	Thru	U-Turn	Peds	App. Total	Thru	Left	U-Turn	Peds	App. Total	Right	Left	U-Turn	Peds	App. Total	
7:00 AM	0	4	0	0	4	19	2	0	1	21	3	3	0	1	6	31
7:15 AM	0	5	0	0	5	50	3	0	0	53	2	4	0	0	6	64
7:30 AM	0	7	0	1	7	90	1	0	0	91	8	8	0	0	16	114
7:45 AM	2	11	0	0	13	68	3	0	0	71	8	3	0	0	11	95
Hourly Total	2	27	0	1	29	227	9	0	1	236	21	18	0	1	39	304
8:00 AM	0	12	0	0	12	63	2	0	0	65	5	5	0	0	10	87
8:15 AM	0	12	0	0	12	47	2	0	0	49	2	3	0	0	5	66
8:30 AM	0	17	0	0	17	25	1	0	0	26	5	5	0	0	10	53
8:45 AM	1	6	0	0	7	7	4	0	0	11	5	2	0	0	7	25
Hourly Total	1	47	0	0	48	142	9	0	0	151	17	15	0	0	32	231
9:00 AM	2	11	0	0	13	9	3	0	0	12	3	1	0	0	4	29
9:15 AM	1	6	0	0	7	7	5	0	0	12	4	1	0	0	5	24
9:30 AM	1	7	0	0	8	6	6	0	0	12	6	1	0	0	7	27
9:45 AM	1	11	0	0	12	18	1	0	0	19	5	2	0	0	7	38
Hourly Total	5	35	0	0	40	40	15	0	0	55	18	5	0	0	23	118
10:00 AM	0	9	0	0	9	3	1	0	0	4	1	4	0	0	5	18
10:15 AM	4	10	0	0	14	5	3	0	0	8	8	0	0	0	8	30
10:30 AM	0	5	0	0	5	11	4	0	0	15	5	4	0	1	9	29
10:45 AM	1	8	0	0	9	8	3	0	0	11	5	2	0	0	7	27
Hourly Total	5	32	0	0	37	27	11	0	0	38	19	10	0	1	29	104
11:00 AM	2	8	0	0	10	7	3	0	2	10	3	2	0	1	5	25
11:15 AM	0	8	0	0	8	10	4	0	0	14	6	0	0	0	6	28
11:30 AM	0	14	0	0	14	10	8	0	0	18	2	1	0	0	3	35
11:45 AM	1	10	0	0	11	14	3	0	0	17	4	2	0	0	6	34
Hourly Total	3	40	0	0	43	41	18	0	2	59	15	5	0	1	20	122
12:00 PM	5	11	0	1	16	11	7	0	1	18	4	3	0	0	7	41
12:15 PM	3	14	0	0	17	13	4	0	0	17	4	1	0	0	5	39
12:30 PM	0	10	0	0	10	12	6	0	0	18	4	0	0	0	4	32
12:45 PM	0	14	0	1	14	11	1	0	0	12	7	4	0	1	11	37
Hourly Total	8	49	0	2	57	47	18	0	1	65	19	8	0	1	27	149
1:00 PM	2	10	0	0	12	8	1	0	0	9	8	0	0	0	8	29
1:15 PM	1	12	0	0	13	10	6	0	0	16	3	0	0	0	3	32
1:30 PM	3	11	0	1	14	11	3	0	0	14	2	0	0	0	2	30
1:45 PM	1	8	0	0	9	9	4	0	0	13	6	0	0	0	6	28
Hourly Total	7	41	0	1	48	38	14	0	0	52	19	0	0	0	19	119
2:00 PM	1	16	0	0	17	11	5	0	0	16	5	1	0	0	6	39
2:15 PM	1	6	0	0	7	13	3	0	1	16	3	5	0	0	8	31
2:30 PM	3	14	0	0	17	8	0	0	1	8	4	0	0	0	4	29
2:45 PM	7	15	0	0	22	10	7	0	0	17	5	1	0	0	6	45

Hourly Total	12	51	0	0	63	42	15	0	2	57	17	7	0	0	24	144
3:00 PM	2	9	0	0	11	13	7	0	0	20	7	0	0	0	7	38
3:15 PM	6	17	0	0	23	8	3	0	0	11	4	1	0	1	5	39
3:30 PM	3	15	0	0	18	11	10	0	0	21	3	1	0	0	4	43
3:45 PM	2	21	0	0	23	12	10	0	0	22	3	1	0	0	4	49
Hourly Total	13	62	0	0	75	44	30	0	0	74	17	3	0	1	20	169
4:00 PM	2	30	0	0	32	12	8	0	0	20	7	2	0	0	9	61
4:15 PM	5	41	0	0	46	7	8	0	0	15	9	1	0	0	10	71
4:30 PM	1	51	0	0	52	14	5	0	0	19	6	0	0	0	6	77
4:45 PM	8	72	0	0	80	14	6	0	0	20	3	0	0	0	3	103
Hourly Total	16	194	0	0	210	47	27	0	0	74	25	3	0	0	28	312
5:00 PM	4	73	0	0	77	15	4	0	0	19	3	0	0	0	3	99
5:15 PM	6	70	0	0	76	11	6	0	3	17	3	1	0	0	4	97
5:30 PM	2	35	0	0	37	11	4	0	1	15	1	3	0	0	4	56
5:45 PM	1	18	0	0	19	13	6	0	0	19	10	0	0	0	10	48
Hourly Total	13	196	0	0	209	50	20	0	4	70	17	4	0	0	21	300
6:00 PM	2	11	0	0	13	19	4	0	3	23	6	1	0	0	7	43
6:15 PM	0	18	0	0	18	7	7	0	0	14	4	0	0	0	4	36
6:30 PM	3	13	0	0	16	13	6	0	0	19	2	1	0	1	3	38
6:45 PM	0	9	0	1	9	11	3	0	2	14	4	2	0	0	6	29
Hourly Total	5	51	0	1	56	50	20	0	5	70	16	4	0	1	20	146
Grand Total	90	825	0	5	915	795	206	0	15	1001	220	82	0	6	302	2218
Approach %	9.8	90.2	0.0	-	-	79.4	20.6	0.0	-	-	72.8	27.2	0.0	-	-	-
Total %	4.1	37.2	0.0	-	41.3	35.8	9.3	0.0	-	45.1	9.9	3.7	0.0	-	13.6	-
All Vehicles (no classification)	90	825	0	-	915	795	206	0	-	1001	220	82	0	-	302	2218
% All Vehicles (no classification)	100.0	100.0	-	-	100.0	100.0	100.0	-	-	100.0	100.0	100.0	-	-	100.0	100.0
Bicycles on Crosswalk	-	-	-	0	-	-	-	-	0	-	-	-	-	1	-	-
% Bicycles on Crosswalk	-	-	-	0.0	-	-	-	-	0.0	-	-	-	-	16.7	-	-
Pedestrians	-	-	-	5	-	-	-	-	15	-	-	-	-	5	-	-
% Pedestrians	-	-	-	100.0	-	-	-	-	100.0	-	-	-	-	83.3	-	-

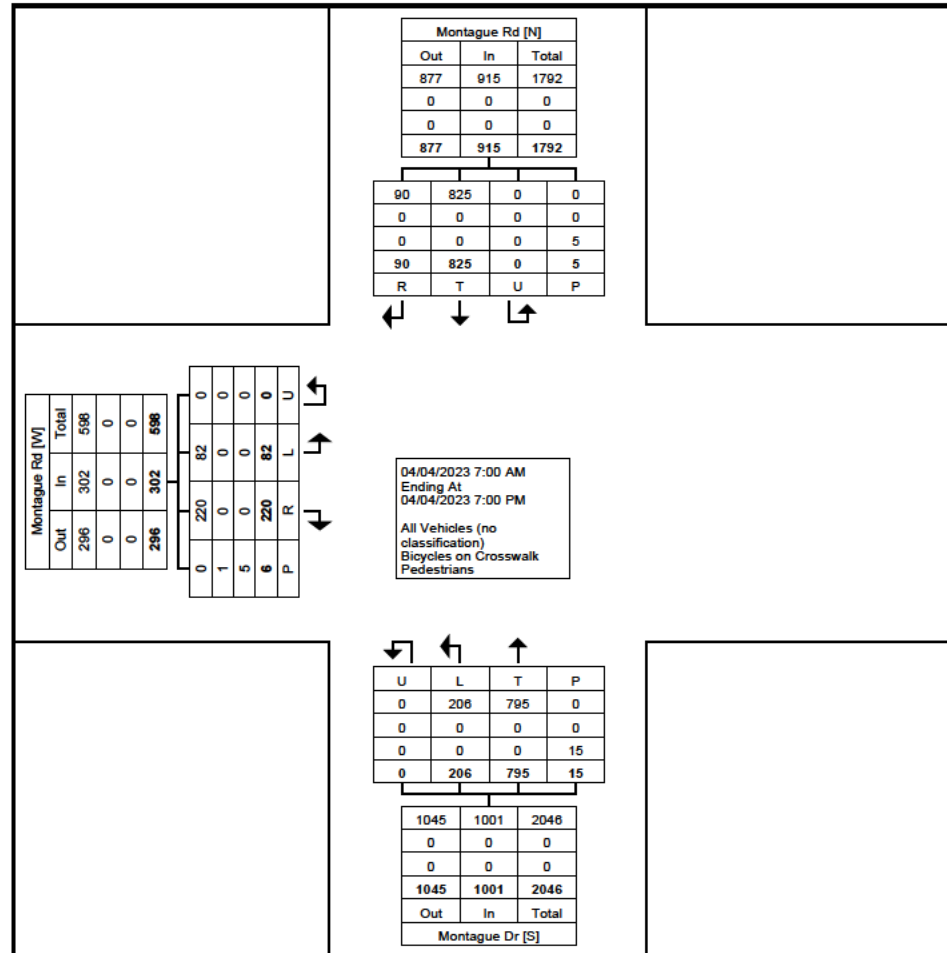

Turning Movement Data Plot

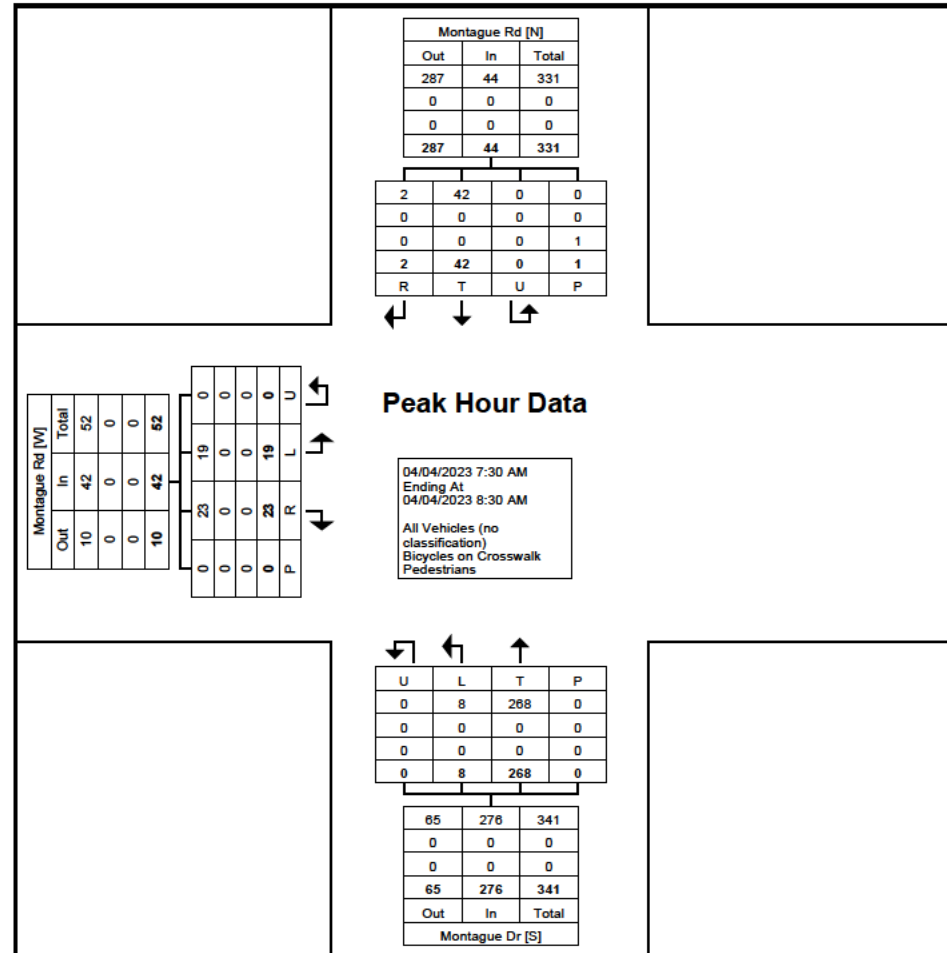

Turning Movement Peak Hour Data Plot (7:30 AM)

Halifax Regional Municipality (Dartmouth, NS)
PO Box 1749

Halifax, Nova Scotia, Canada B3J 3A5
(902) 490-4866

Count Name: 23RQ354
Site Code: Montague Dr and Montague Rd
Start Date: 04/04/2023
Page No: 6

Turning Movement Peak Hour Data (4:30 PM)

Start Time	Montague Rd Southbound					Montague Dr Northbound					Montague Rd Eastbound					Int. Total
	Right	Thru	U-Turn	Peds	App. Total	Thru	Left	U-Turn	Peds	App. Total	Right	Left	U-Turn	Peds	App. Total	
4:30 PM	1	51	0	0	52	14	5	0	0	19	6	0	0	0	6	77
4:45 PM	8	72	0	0	80	14	6	0	0	20	3	0	0	0	3	103
5:00 PM	4	73	0	0	77	15	4	0	0	19	3	0	0	0	3	99
5:15 PM	6	70	0	0	76	11	6	0	3	17	3	1	0	0	4	97
Total	19	266	0	0	285	54	21	0	3	75	15	1	0	0	16	376
Approach %	6.7	93.3	0.0	-	-	72.0	28.0	0.0	-	-	93.8	6.3	0.0	-	-	-
Total %	5.1	70.7	0.0	-	75.8	14.4	5.6	0.0	-	19.9	4.0	0.3	0.0	-	4.3	-
PHF	0.594	0.911	0.000	-	0.891	0.900	0.875	0.000	-	0.938	0.625	0.250	0.000	-	0.667	0.913
All Vehicles (no classification)	19	266	0	-	285	54	21	0	-	75	15	1	0	-	16	376
% All Vehicles (no classification)	100.0	100.0	-	-	100.0	100.0	100.0	-	-	100.0	100.0	100.0	-	-	100.0	100.0
Bicycles on Crosswalk	-	-	-	0	-	-	-	-	0	-	-	-	-	0	-	-
% Bicycles on Crosswalk	-	-	-	-	-	-	-	-	0.0	-	-	-	-	-	-	-
Pedestrians	-	-	-	0	-	-	-	-	3	-	-	-	-	0	-	-
% Pedestrians	-	-	-	-	-	-	-	-	100.0	-	-	-	-	-	-	-

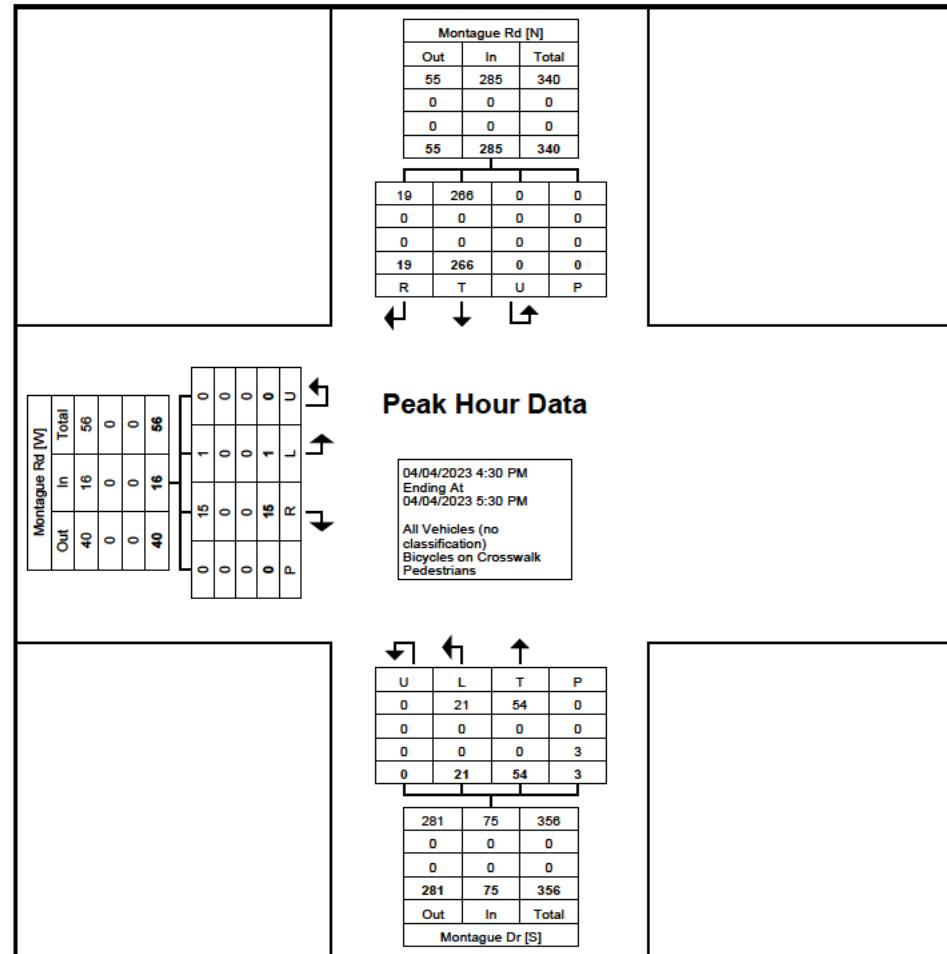

Turning Movement Peak Hour Data Plot (4:30 PM)

Merged Weekly Counts
23RQ057

from Mon-May-08-2023-02-00-PM to Mon-May-15-2023-08-59-AM

Lakehill Dr - Between Lochmoor Ln and Montague Rd - Civic 27

AWT: 694

	5/8/2023	to	5/14/2023							
	Monday	Tuesday	Wednesday	Thursday	Friday	Saturday	Sunday	Week	Weekend	Week Day 85%
Hour	5/8/2023	5/9/2023	5/10/2023	5/11/2023	5/12/2023	5/13/2023	5/14/2023	Day Avg	Avg	Avg Speed
0 - 1	*	3	2	1	5	3	5	2.75	4	53.75
1 - 2	*	2	0	2	2	7	4	1.5	5.5	47.67
2 - 3	*	0	3	2	2	4	1	1.75	2.5	34.67
3 - 4	*	4	0	0	1	5	0	1.25	2.5	36
4 - 5	*	0	0	2	1	0	0	0.75	0	39.5
5 - 6	*	8	6	5	10	1	2	7.25	1.5	55.88
6 - 7	*	20	17	15	16	8	4	17	6	49
7 - 8	*	47	39	40	44	14	8	42.5	11	50.58
8 - 9	*	37	34	38	38	20	21	36.75	20.5	51.8
9 - 10	*	32	43	51	61	50	39	46.75	44.5	45.92
10 - 11	*	31	28	41	47	50	41	36.75	45.5	47.6
11 - 12	*	25	46	45	49	47	40	41.25	43.5	47.75
12 - 13	*	34	41	45	40	51	57	40	54	49.7
13 - 14	*	41	48	45	34	52	47	42	49.5	48.85
14 - 15	30	47	50	58	56	28	44	48.2	36	50.52
15 - 16	33	55	42	49	72	53	47	50.2	50	49.82
16 - 17	50	69	53	68	71	36	63	62.2	49.5	48.7
17 - 18	45	42	49	56	69	37	39	52.2	38	50.06
18 - 19	37	31	34	25	42	32	32	33.8	32	48.08
19 - 20	32	41	40	50	52	27	29	43	28	48.56
20 - 21	29	32	29	33	36	18	23	31.8	20.5	49.36
21 - 22	15	17	19	19	21	16	17	18.2	16.5	48.8
22 - 23	9	5	6	11	21	10	9	10.4	9.5	47.1
23 - 24	5	10	8	6	8	10	9	7.4	9.5	49.4
Totals	285	633	637	707	798	579	581			
% of Total	6.75%	15%	15.09%	16.75%	18.91%	13.72%	13.77%			

Hour	5/15/2023	to	5/21/2023	Thursday	Friday	Saturday	Sunday	Week	Weekend	Week Day 85%
	Monday	Tuesday	Wednesday							
	5/15/2023	5/16/2023	5/17/2023	5/18/2023	5/19/2023	5/20/2023	5/21/2023	Day Avg	Avg	Avg Speed
0 - 1	0	*	*	*	*	*	*	0	0	0
1 - 2	1	*	*	*	*	*	*	1	0	38
2 - 3	1	*	*	*	*	*	*	1	0	41
3 - 4	0	*	*	*	*	*	*	0	0	0
4 - 5	0	*	*	*	*	*	*	0	0	0
5 - 6	8	*	*	*	*	*	*	8	0	48
6 - 7	11	*	*	*	*	*	*	11	0	51
7 - 8	40	*	*	*	*	*	*	40	0	56
8 - 9	15	*	*	*	*	*	*	15	0	57
9 - 10	*	*	*	*	*	*	*	0	0	0
10 - 11	*	*	*	*	*	*	*	0	0	0
11 - 12	*	*	*	*	*	*	*	0	0	0
12 - 13	*	*	*	*	*	*	*	0	0	0
13 - 14	*	*	*	*	*	*	*	0	0	0
14 - 15	*	*	*	*	*	*	*	0	0	0
15 - 16	*	*	*	*	*	*	*	0	0	0
16 - 17	*	*	*	*	*	*	*	0	0	0
17 - 18	*	*	*	*	*	*	*	0	0	0
18 - 19	*	*	*	*	*	*	*	0	0	0
19 - 20	*	*	*	*	*	*	*	0	0	0
20 - 21	*	*	*	*	*	*	*	0	0	0
21 - 22	*	*	*	*	*	*	*	0	0	0
22 - 23	*	*	*	*	*	*	*	0	0	0
23 - 24	*	*	*	*	*	*	*	0	0	0
Totals	76	0	0	0	0	0	0			
% of Total	100%	0%	0%	0%	0%	0%	0%			

EB Weekly Counts

23RQ057

from Mon-May-08-2023-02-00-PM to Mon-May-15-2023-08-59-AM

Lakehill Dr - Between Lochmoor Ln and Montague Rd - Civic 27

AWT: 326

	5/8/2023	to	5/14/2023							
	Monday	Tuesday	Wednesday	Thursday	Friday	Saturday	Sunday	Week	Weekend	Week Day 85%
Hour	5/8/2023	5/9/2023	5/10/2023	5/11/2023	5/12/2023	5/13/2023	5/14/2023	Day Avg	Avg	Avg Speed
0 - 1	*	2	1	1	1	2	2	1.25	2	51.25
1 - 2	*	1	0	1	2	3	2	1	2.5	44.67
2 - 3	*	0	2	0	1	1	0	0.75	0.5	27
3 - 4	*	2	0	0	0	3	0	0.5	1.5	33
4 - 5	*	0	0	1	0	0	0	0.25	0	35
5 - 6	*	2	0	0	3	0	1	1.25	0.5	48.5
6 - 7	*	7	4	4	4	2	1	4.75	1.5	47
7 - 8	*	8	8	6	11	3	2	8.25	2.5	49.25
8 - 9	*	14	11	17	13	3	10	13.75	6.5	52
9 - 10	*	9	16	18	23	25	12	16.5	18.5	44.25
10 - 11	*	11	9	22	23	18	18	16.25	18	47.82
11 - 12	*	11	21	20	22	22	13	18.5	17.5	48.32
12 - 13	*	17	17	24	19	24	32	19.25	28	47.75
13 - 14	*	19	25	18	16	23	25	19.5	24	47.45
14 - 15	13	25	24	28	32	10	21	24.4	15.5	50.46
15 - 16	18	32	24	31	37	28	25	28.4	26.5	49.04
16 - 17	32	41	32	43	39	17	30	37.4	23.5	48.6
17 - 18	24	24	28	28	29	18	20	26.6	19	50.9
18 - 19	19	13	16	10	18	16	15	15.2	15.5	47.7
19 - 20	18	23	20	25	31	15	19	23.4	17	49.16
20 - 21	17	18	17	18	22	11	9	18.4	10	48
21 - 22	7	12	12	12	9	10	9	10.4	9.5	47.6
22 - 23	5	3	4	5	12	8	7	5.8	7.5	47.2
23 - 24	3	6	7	4	3	7	3	4.6	5	50.4
Totals	156	300	298	336	370	269	276			
% of Total	7.78%	14.96%	14.86%	16.76%	18.45%	13.42%	13.77%			

Hour	5/15/2023	to	5/21/2023	Thursday	Friday	Saturday	Sunday	Week	Weekend	Week Day 85%
	Monday	Tuesday	Wednesday							
	5/15/2023	5/16/2023	5/17/2023	5/18/2023	5/19/2023	5/20/2023	5/21/2023	Day Avg	Avg	Avg Speed
0 - 1	0	*	*	*	*	*	*	0	0	0
1 - 2	1	*	*	*	*	*	*	1	0	38
2 - 3	0	*	*	*	*	*	*	0	0	0
3 - 4	0	*	*	*	*	*	*	0	0	0
4 - 5	0	*	*	*	*	*	*	0	0	0
5 - 6	1	*	*	*	*	*	*	1	0	48
6 - 7	4	*	*	*	*	*	*	4	0	46
7 - 8	12	*	*	*	*	*	*	12	0	52
8 - 9	6	*	*	*	*	*	*	6	0	50
9 - 10	*	*	*	*	*	*	*	0	0	0
10 - 11	*	*	*	*	*	*	*	0	0	0
11 - 12	*	*	*	*	*	*	*	0	0	0
12 - 13	*	*	*	*	*	*	*	0	0	0
13 - 14	*	*	*	*	*	*	*	0	0	0
14 - 15	*	*	*	*	*	*	*	0	0	0
15 - 16	*	*	*	*	*	*	*	0	0	0
16 - 17	*	*	*	*	*	*	*	0	0	0
17 - 18	*	*	*	*	*	*	*	0	0	0
18 - 19	*	*	*	*	*	*	*	0	0	0
19 - 20	*	*	*	*	*	*	*	0	0	0
20 - 21	*	*	*	*	*	*	*	0	0	0
21 - 22	*	*	*	*	*	*	*	0	0	0
22 - 23	*	*	*	*	*	*	*	0	0	0
23 - 24	*	*	*	*	*	*	*	0	0	0
Totals	24	0	0	0	0	0	0			
% of Total	100%	0%	0%	0%	0%	0%	0%			

WB Weekly Counts
23RQ057

from Mon-May-08-2023-02-00-PM to Mon-May-15-2023-08-59-AM

Lakehill Dr - Between Lochmoor Ln and Montague Rd - Civic 27

AWT: 368

	5/8/2023	to	5/14/2023							
	Monday	Tuesday	Wednesday	Thursday	Friday	Saturday	Sunday	Week	Weekend	Week Day 85%
Hour	5/8/2023	5/9/2023	5/10/2023	5/11/2023	5/12/2023	5/13/2023	5/14/2023	Day Avg	Avg	Avg Speed
0 - 1	*	1	1	0	4	1	3	1.5	2	53.33
1 - 2	*	1	0	1	0	4	2	0.5	3	48
2 - 3	*	0	1	2	1	3	1	1	2	34.67
3 - 4	*	2	0	0	1	2	0	0.75	1	36.5
4 - 5	*	0	0	1	1	0	0	0.5	0	39.5
5 - 6	*	6	6	5	7	1	1	6	1	55.88
6 - 7	*	13	13	11	12	6	3	12.25	4.5	48.25
7 - 8	*	39	31	34	33	11	6	34.25	8.5	50.75
8 - 9	*	23	23	21	25	17	11	23	14	51.88
9 - 10	*	23	27	33	38	25	27	30.25	26	46.5
10 - 11	*	20	19	19	24	32	23	20.5	27.5	47
11 - 12	*	14	25	25	27	25	27	22.75	26	47.2
12 - 13	*	17	24	21	21	27	25	20.75	26	50.12
13 - 14	*	22	23	27	18	29	22	22.5	25.5	49.75
14 - 15	19	22	26	30	24	18	23	24.2	20.5	51.16
15 - 16	15	23	18	18	35	25	22	21.8	23.5	49.88
16 - 17	18	28	21	25	32	19	33	24.8	26	47.94
17 - 18	21	18	21	28	40	19	19	25.6	19	48.56
18 - 19	18	18	18	15	24	16	17	18.6	16.5	48.1
19 - 20	14	18	20	25	21	12	10	19.6	11	47.9
20 - 21	12	14	12	15	14	7	14	13.4	10.5	48.9
21 - 22	8	5	7	7	12	6	8	7.8	7	50.6
22 - 23	4	2	2	6	9	2	2	4.6	2	46.5
23 - 24	2	4	1	2	5	3	6	2.8	4.5	46.8
Totals	131	333	339	371	428	310	305			
% of Total	5.91%	15.02%	15.29%	16.73%	19.31%	13.98%	13.76%			

Hour	5/15/2023	to	5/21/2023	Thursday	Friday	Saturday	Sunday	Week	Weekend	Week Day 85%
	Monday	Tuesday	Wednesday							
	5/15/2023	5/16/2023	5/17/2023	5/18/2023	5/19/2023	5/20/2023	5/21/2023	Day Avg	Avg	Avg Speed
0 - 1	0	*	*	*	*	*	*	0	0	0
1 - 2	0	*	*	*	*	*	*	0	0	0
2 - 3	1	*	*	*	*	*	*	1	0	41
3 - 4	0	*	*	*	*	*	*	0	0	0
4 - 5	0	*	*	*	*	*	*	0	0	0
5 - 6	7	*	*	*	*	*	*	7	0	48
6 - 7	7	*	*	*	*	*	*	7	0	51
7 - 8	28	*	*	*	*	*	*	28	0	56
8 - 9	9	*	*	*	*	*	*	9	0	61
9 - 10	*	*	*	*	*	*	*	0	0	0
10 - 11	*	*	*	*	*	*	*	0	0	0
11 - 12	*	*	*	*	*	*	*	0	0	0
12 - 13	*	*	*	*	*	*	*	0	0	0
13 - 14	*	*	*	*	*	*	*	0	0	0
14 - 15	*	*	*	*	*	*	*	0	0	0
15 - 16	*	*	*	*	*	*	*	0	0	0
16 - 17	*	*	*	*	*	*	*	0	0	0
17 - 18	*	*	*	*	*	*	*	0	0	0
18 - 19	*	*	*	*	*	*	*	0	0	0
19 - 20	*	*	*	*	*	*	*	0	0	0
20 - 21	*	*	*	*	*	*	*	0	0	0
21 - 22	*	*	*	*	*	*	*	0	0	0
22 - 23	*	*	*	*	*	*	*	0	0	0
23 - 24	*	*	*	*	*	*	*	0	0	0
Totals	52	0	0	0	0	0	0			
% of Total	100%	0%	0%	0%	0%	0%	0%			

Main and Montague - AM - TMC

Tue Jun 13, 2023

Full Length (7 AM-9 AM)

All Classes (Lights, Articulated Trucks, Buses and Single-Unit Trucks, Pedestrians, Bicycles on Road)

All Movements

ID: 1080509, Location: 44.69804, -63.493034

Provided by: Trans4m Development Group

59 Craighburn Drive,

Dartmouth, NS, B2X 3E6, CA

Leg Direction	Main St - EB Eastbound						Main St - WB Westbound						Hillsboro Dr - NB Northbound						Montague Rd - SB Southbound						Int
	L	T	R	U	App	Ped*	L	T	R	U	App	Ped*	L	T	R	U	App	Ped*	L	T	R	U	App	Ped*	
2023-06-13																									
7:00AM	21	85	11	0	117	0	3	360	27	0	390	0	16	4	2	0	22	0	2	4	13	0	19	0	548
7:15AM	8	117	14	0	139	0	4	314	29	0	347	0	13	7	1	0	21	0	2	2	13	0	17	1	524
7:30AM	20	124	11	0	155	0	10	327	65	0	402	0	20	6	2	0	28	0	4	7	14	0	25	0	610
7:45AM	22	139	17	0	178	0	13	253	43	0	309	0	18	19	1	0	38	0	4	7	26	0	37	1	562
Hourly Total	71	465	53	0	589	0	30	1254	164	0	1448	0	67	36	6	0	109	0	12	20	66	0	98	2	2244
8:00AM	13	128	13	0	154	0	16	302	35	0	353	0	12	14	0	0	26	0	9	10	27	0	46	0	579
8:15AM	11	159	13	0	183	1	10	291	40	0	341	1	17	8	0	0	25	1	3	6	8	0	17	1	566
8:30AM	24	174	14	0	212	0	5	291	5	0	301	0	22	2	3	0	27	0	3	1	22	0	26	0	566
8:45AM	31	193	17	0	241	0	6	250	5	0	261	0	20	1	7	0	28	1	7	3	22	0	32	0	562
Hourly Total	79	654	57	0	790	1	37	1134	85	0	1256	1	71	25	10	0	106	2	22	20	79	0	121	1	2273
Total	150	1119	110	0	1379	1	67	2388	249	0	2704	1	138	61	16	0	215	2	34	40	145	0	219	3	4517
% Approach	10.9%	81.1%	8.0%	0%	-	-	2.5%	88.3%	9.2%	0%	-	-	64.2%	28.4%	7.4%	0%	-	-	15.5%	18.3%	66.2%	0%	-	-	-
% Total	3.3%	24.8%	2.4%	0%	30.5%	-	1.5%	52.9%	5.5%	0%	59.9%	-	3.1%	1.4%	0.4%	0%	4.8%	-	0.8%	0.9%	3.2%	0%	4.8%	-	-
Lights	148	1015	100	0	1263	-	60	2290	247	0	2597	-	133	56	14	0	203	-	33	39	139	0	211	-	4274
% Lights	98.7%	90.7%	90.9%	0%	91.6%	-	89.6%	95.9%	99.2%	0%	96.0%	-	96.4%	91.8%	87.5%	0%	94.4%	-	97.1%	97.5%	95.9%	0%	96.3%	-	94.6%
Articulated Trucks	0	15	0	0	15	-	0	17	0	0	17	-	0	0	0	0	0	-	0	0	0	0	0	-	32
% Articulated Trucks	0%	1.3%	0%	0%	1.1%	-	0%	0.7%	0%	0%	0.6%	-	0%	0%	0%	0%	0%	-	0%	0%	0%	0%	0%	-	0.7%
Buses and Single-Unit Trucks	2	88	10	0	100	-	7	81	2	0	90	-	5	4	2	0	11	-	1	1	6	0	8	-	209
% Buses and Single-Unit Trucks	1.3%	7.9%	9.1%	0%	7.3%	-	10.4%	3.4%	0.8%	0%	3.3%	-	3.6%	6.6%	12.5%	0%	5.1%	-	2.9%	2.5%	4.1%	0%	3.7%	-	4.6%
Bicycles on Road	0	1	0	0	1	-	0	0	0	0	0	-	0	1	0	0	1	-	0	0	0	0	0	-	2
% Bicycles on Road	0%	0.1%	0%	0%	0.1%	-	0%	0%	0%	0%	0%	-	0%	1.6%	0%	0%	0.5%	-	0%	0%	0%	0%	0%	-	0%
Pedestrians	-	-	-	-	-	1	-	-	-	-	-	1	-	-	-	-	-	2	-	-	-	-	-	3	
% Pedestrians	-	-	-	-	-	100%	-	-	-	-	-	100%	-	-	-	-	-	100%	-	-	-	-	-	100%	

*Pedestrians and Bicycles on Crosswalk. L: Left, R: Right, T: Thru, U: U-Turn

Main and Montague - AM - TMC

Tue Jun 13, 2023

Full Length (7 AM-9 AM)

All Classes (Lights, Articulated Trucks, Buses and Single-Unit Trucks, Pedestrians, Bicycles on Road)

All Movements

ID: 1080509, Location: 44.69804, -63.493034

Provided by: Trans4m Development Group

59 Craighburn Drive,

Dartmouth, NS, B2X 3E6, CA

[N] Montague Rd - SB

Total: 679

In: 219 Out: 460

145
40
34



[W] Main St - EB
Total: 4050
In: 1379 Out: 2671

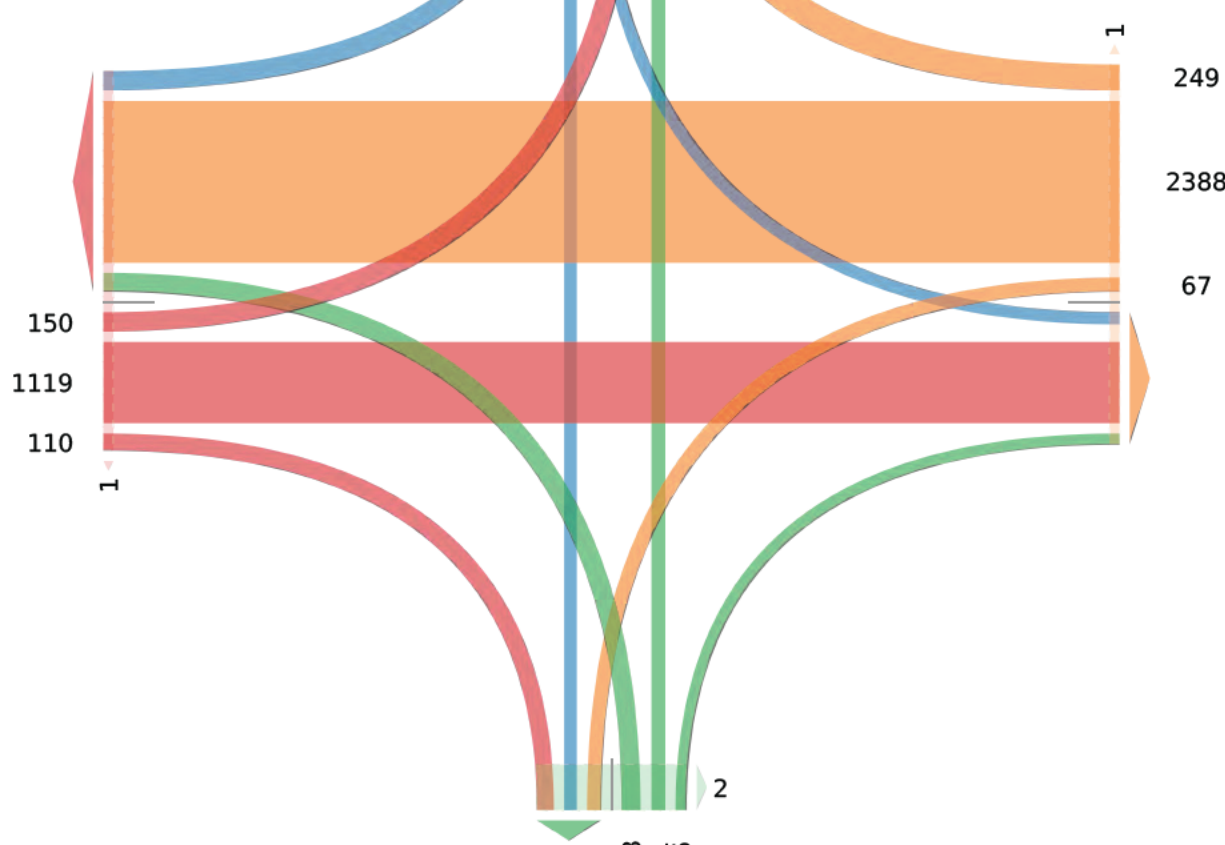

[E] Main St - WB
Total: 3873
In: 2704 Out: 1169

[S] Hillsboro Dr - NB
Total: 432
In: 215 Out: 217

138
61
16

Main and Montague - AM - TMC

Tue Jun 13, 2023

AM Peak (7:30 AM - 8:30 AM) - Overall Peak Hour

All Classes (Lights, Articulated Trucks, Buses and Single-Unit Trucks, Pedestrians, Bicycles on Road)

All Movements

ID: 1080509, Location: 44.69804, -63.493034

Provided by: Trans4m Development Group

59 Craighburn Drive,

Dartmouth, NS, B2X 3E6, CA

Leg Direction	Main St - EB Eastbound						Main St - WB Westbound						Hillsboro Dr - NB Northbound						Montague Rd - SB Southbound						Int
	L	T	R	U	App	Ped*	L	T	R	U	App	Ped*	L	T	R	U	App	Ped*	L	T	R	U	App	Ped*	
2023-06-13																									
7:30AM	20	124	11	0	155	0	10	327	65	0	402	0	20	6	2	0	28	0	4	7	14	0	25	0	610
7:45AM	22	139	17	0	178	0	13	253	43	0	309	0	18	19	1	0	38	0	4	7	26	0	37	1	562
8:00AM	13	128	13	0	154	0	16	302	35	0	353	0	12	14	0	0	26	0	9	10	27	0	46	0	579
8:15AM	11	159	13	0	183	1	10	291	40	0	341	1	17	8	0	0	25	1	3	6	8	0	17	1	566
Total	66	550	54	0	670	1	49	1173	183	0	1405	1	67	47	3	0	117	1	20	30	75	0	125	2	2317
% Approach	9.9%	82.1%	8.1%	0%	-	-	3.5%	83.5%	13.0%	0%	-	-	57.3%	40.2%	2.6%	0%	-	-	16.0%	24.0%	60.0%	0%	-	-	-
% Total	2.8%	23.7%	2.3%	0%	28.9%	-	2.1%	50.6%	7.9%	0%	60.6%	-	2.9%	2.0%	0.1%	0%	5.0%	-	0.9%	1.3%	3.2%	0%	5.4%	-	-
PHF	0.750	0.865	0.794	-	0.915	-	0.766	0.897	0.704	-	0.874	-	0.838	0.618	0.375	-	0.770	-	0.556	0.750	0.694	-	0.679	-	0.950
Lights	65	500	50	0	615	-	45	1125	182	0	1352	-	65	44	2	0	111	-	19	30	73	0	122	-	2200
% Lights	98.5%	90.9%	92.6%	0%	91.8%	-	91.8%	95.9%	99.5%	0%	96.2%	-	97.0%	93.6%	66.7%	0%	94.9%	-	95.0%	100%	97.3%	0%	97.6%	-	95.0%
Articulated Trucks	0	8	0	0	8	-	0	9	0	0	9	-	0	0	0	0	0	-	0	0	0	0	0	-	17
% Articulated Trucks	0%	1.5%	0%	0%	1.2%	-	0%	0.8%	0%	0%	0.6%	-	0%	0%	0%	0%	0%	-	0%	0%	0%	0%	0%	-	0.7%
Buses and Single-Unit Trucks	1	42	4	0	47	-	4	39	1	0	44	-	2	3	1	0	6	-	1	0	2	0	3	-	100
% Buses and Single-Unit Trucks	1.5%	7.6%	7.4%	0%	7.0%	-	8.2%	3.3%	0.5%	0%	3.1%	-	3.0%	6.4%	33.3%	0%	5.1%	-	5.0%	0%	2.7%	0%	2.4%	-	4.3%
Bicycles on Road	0	0	0	0	0	-	0	0	0	0	0	-	0	0	0	0	0	-	0	0	0	0	0	-	0
% Bicycles on Road	0%	0%	0%	0%	0%	-	0%	0%	0%	0%	0%	-	0%	0%	0%	0%	0%	-	0%	0%	0%	0%	0%	-	0%
Pedestrians	-	-	-	-	-	1	-	-	-	-	-	1	-	-	-	-	-	1	-	-	-	-	-	2	-
% Pedestrians	-	-	-	-	-	100%	-	-	-	-	-	100%	-	-	-	-	-	100%	-	-	-	-	-	100%	-

* Pedestrians and Bicycles on Crosswalk. L: Left, R: Right, T: Thru, U: U-Turn

Main and Montague - AM - TMC

Tue Jun 13, 2023

AM Peak (7:30 AM - 8:30 AM) - Overall Peak Hour

All Classes (Lights, Articulated Trucks, Buses and Single-Unit Trucks, Pedestrians, Bicycles on Road)

All Movements

ID: 1080509, Location: 44.69804, -63.493034

Provided by: Trans4m Development Group

59 Craighburn Drive,

Dartmouth, NS, B2X 3E6, CA

[N] Montague Rd - SB

Total: 421

In: 125 Out: 296

75 30 20

1 1

[W] Main St - EB
Total: 1985
In: 670 Out: 1315

66
550
54

1

183
1173
49

Out: 573 In: 1405
Total: 1978
[E] Main St - WB

67 47 3

Out: 133 In: 117
Total: 250

[S] Hillsboro Dr - NB

Main Street and Montague - PM - TMC

Tue Jun 13, 2023

Full Length (4 PM-6 PM)

All Classes (Lights, Articulated Trucks, Buses and Single-Unit Trucks, Pedestrians, Bicycles on Road)

All Movements

ID: 1080510, Location: 44.69804, -63.493034

Provided by: Trans4m Development Group

59 Craighburn Drive,

Dartmouth, NS, B2X 3E6, CA

Leg Direction	Main St. - EB Eastbound						Main St. - WB Westbound						Hillsboro Dr. - NB Northbound						Montague Rd - SB Southbound						Int
	L	T	R	U	App	Ped*	L	T	R	U	App	Ped*	L	T	R	U	App	Ped*	L	T	R	U	App	Ped*	
2023-06-13																									
4:00PM	33	428	27	0	488	0	6	236	6	0	248	2	28	2	8	0	38	1	15	5	22	0	42	0	816
4:15PM	37	387	35	0	459	0	8	169	9	0	186	0	14	7	5	0	26	1	44	9	20	0	73	1	744
4:30PM	20	375	34	0	429	0	6	204	2	0	212	1	19	5	6	0	30	0	39	14	24	0	77	2	748
4:45PM	24	369	45	0	438	0	11	183	5	0	199	0	13	5	3	0	21	4	60	20	12	0	92	0	750
Hourly Total	114	1559	141	0	1814	0	31	792	22	0	845	3	74	19	22	0	115	6	158	48	78	0	284	3	3058
5:00PM	33	363	35	0	431	0	13	204	10	0	227	0	25	6	4	0	35	0	56	16	26	0	98	0	791
5:15PM	34	381	35	0	450	0	5	215	9	0	229	3	13	8	6	0	27	0	58	19	20	0	97	0	803
5:30PM	32	364	48	0	444	0	3	197	7	0	207	2	17	11	2	0	30	0	43	22	31	0	96	0	777
5:45PM	32	351	35	0	418	0	5	161	13	0	179	0	13	10	3	0	26	0	18	13	39	0	70	0	693
Hourly Total	131	1459	153	0	1743	0	26	777	39	0	842	5	68	35	15	0	118	0	175	70	116	0	361	0	3064
Total	245	3018	294	0	3557	0	57	1569	61	0	1687	8	142	54	37	0	233	6	333	118	194	0	645	3	6122
% Approach	6.9%	84.8%	8.3%	0%	-	-	3.4%	93.0%	3.6%	0%	-	-	60.9%	23.2%	15.9%	0%	-	-	51.6%	18.3%	30.1%	0%	-	-	-
% Total	4.0%	49.3%	4.8%	0%	58.1%	-	0.9%	25.6%	1.0%	0%	27.6%	-	2.3%	0.9%	0.6%	0%	3.8%	-	5.4%	1.9%	3.2%	0%	10.5%	-	-
Lights	243	2944	291	0	3478	-	55	1506	59	0	1620	-	138	51	37	0	226	-	329	118	193	0	640	-	5964
% Lights	99.2%	97.5%	99.0%	0%	97.8%	-	96.5%	96.0%	96.7%	0%	96.0%	-	97.2%	94.4%	100%	0%	97.0%	-	98.8%	100%	99.5%	0%	99.2%	-	97.4%
Articulated Trucks	1	5	0	0	6	-	0	9	0	0	9	-	0	0	0	0	0	-	0	0	0	0	0	-	15
% Articulated Trucks	0.4%	0.2%	0%	0%	0.2%	-	0%	0.6%	0%	0%	0.5%	-	0%	0%	0%	0%	0%	-	0%	0%	0%	0%	0%	-	0.2%
Buses and Single-Unit Trucks	1	69	3	0	73	-	2	54	2	0	58	-	4	3	0	0	7	-	4	0	1	0	5	-	143
% Buses and Single-Unit Trucks	0.4%	2.3%	1.0%	0%	2.1%	-	3.5%	3.4%	3.3%	0%	3.4%	-	2.8%	5.6%	0%	0%	3.0%	-	1.2%	0%	0.5%	0%	0.8%	-	2.3%
Bicycles on Road	0	0	0	0	0	-	0	0	0	0	0	-	0	0	0	0	0	-	0	0	0	0	0	-	0
% Bicycles on Road	0%	0%	0%	0%	0%	-	0%	0%	0%	0%	0%	-	0%	0%	0%	0%	0%	-	0%	0%	0%	0%	0%	-	0%
Pedestrians	-	-	-	-	-	0	-	-	-	-	-	8	-	-	-	-	-	6	-	-	-	-	-	3	
% Pedestrians	-	-	-	-	-	-	-	-	-	-	-	100%	-	-	-	-	-	100%	-	-	-	-	-	100%	-

*Pedestrians and Bicycles on Crosswalk. L: Left, R: Right, T: Thru, U: U-Turn

Main Street and Montague - PM - TMC

Tue Jun 13, 2023

Full Length (4 PM-6 PM)

All Classes (Lights, Articulated Trucks, Buses and Single-Unit Trucks, Pedestrians, Bicycles on Road)

All Movements

ID: 1080510, Location: 44.69804, -63.493034

Provided by: Trans4m Development Group

59 Craighburn Drive,

Dartmouth, NS, B2X 3E6, CA

[N] Montague Rd - SB

Total: 1005

In: 645 Out: 360

194
118
333

3

5

142
54
37

1

Out: 469 In: 233

Total: 702

[S] Hillsboro Dr. - NB

[W] Main St. - EB

Total: 5462
In: 3557 Out: 1905

245

3018

294

5

61

1569

57

Out: 3388 In: 1687

Total: 5075

[E] Main St. - WB

3

Main Street and Montague - PM - TMC

Tue Jun 13, 2023

PM Peak (4:45 PM - 5:45 PM) - Overall Peak Hour

All Classes (Lights, Articulated Trucks, Buses and Single-Unit Trucks, Pedestrians, Bicycles on Road)

All Movements

ID: 1080510, Location: 44.69804, -63.493034

Provided by: Trans4m Development Group

59 Craighburn Drive,

Dartmouth, NS, B2X 3E6, CA

Leg Direction	Main St. - EB Eastbound						Main St. - WB Westbound						Hillsboro Dr. - NB Northbound						Montague Rd - SB Southbound						Int
	L	T	R	U	App	Ped*	L	T	R	U	App	Ped*	L	T	R	U	App	Ped*	L	T	R	U	App	Ped*	
2023-06-13 4:45PM	24	369	45	0	438	0	11	183	5	0	199	0	13	5	3	0	21	4	60	20	12	0	92	0	750
5:00PM	33	363	35	0	431	0	13	204	10	0	227	0	25	6	4	0	35	0	56	16	26	0	98	0	791
5:15PM	34	381	35	0	450	0	5	215	9	0	229	3	13	8	6	0	27	0	58	19	20	0	97	0	803
5:30PM	32	364	48	0	444	0	3	197	7	0	207	2	17	11	2	0	30	0	43	22	31	0	96	0	777
Total	123	1477	163	0	1763	0	32	799	31	0	862	5	68	30	15	0	113	4	217	77	89	0	383	0	3121
% Approach	7.0%	83.8%	9.2%	0%	-	-	3.7%	92.7%	3.6%	0%	-	-	60.2%	26.5%	13.3%	0%	-	-	56.7%	20.1%	23.2%	0%	-	-	-
% Total	3.9%	47.3%	5.2%	0%	56.5%	-	1.0%	25.6%	1.0%	0%	27.6%	-	2.2%	1.0%	0.5%	0%	3.6%	-	7.0%	2.5%	2.9%	0%	12.3%	-	-
PHF	0.904	0.969	0.849	-	0.979	-	0.615	0.929	0.775	-	0.941	-	0.680	0.682	0.625	-	0.807	-	0.904	0.875	0.718	-	0.977	-	0.972
Lights	123	1439	161	0	1723	-	31	773	30	0	834	-	64	29	15	0	108	-	214	77	89	0	380	-	3045
% Lights	100%	97.4%	98.8%	0%	97.7%	-	96.9%	96.7%	96.8%	0%	96.8%	-	94.1%	96.7%	100%	0%	95.6%	-	98.6%	100%	100%	0%	99.2%	-	97.6%
Articulated Trucks	0	3	0	0	3	-	0	5	0	0	5	-	0	0	0	0	0	-	0	0	0	0	0	-	8
% Articulated Trucks	0%	0.2%	0%	0%	0.2%	-	0%	0.6%	0%	0%	0.6%	-	0%	0%	0%	0%	0%	-	0%	0%	0%	0%	0%	-	0.3%
Buses and Single-Unit Trucks	0	35	2	0	37	-	1	21	1	0	23	-	4	1	0	0	5	-	3	0	0	0	3	-	68
% Buses and Single-Unit Trucks	0%	2.4%	1.2%	0%	2.1%	-	3.1%	2.6%	3.2%	0%	2.7%	-	5.9%	3.3%	0%	0%	4.4%	-	1.4%	0%	0%	0%	0.8%	-	2.2%
Bicycles on Road	0	0	0	0	0	-	0	0	0	0	0	-	0	0	0	0	0	-	0	0	0	0	0	-	0
% Bicycles on Road	0%	0%	0%	0%	0%	-	0%	0%	0%	0%	0%	-	0%	0%	0%	0%	0%	-	0%	0%	0%	0%	0%	-	0%
Pedestrians	-	-	-	-	-	0	-	-	-	-	-	5	-	-	-	-	-	4	-	-	-	-	-	0	
% Pedestrians	-	-	-	-	-	-	-	-	-	-	-	-100%	-	-	-	-	-	-100%	-	-	-	-	-	-	

*Pedestrians and Bicycles on Crosswalk. L: Left, R: Right, T: Thru, U: U-Turn

Main Street and Montague - PM - TMC

Tue Jun 13, 2023

PM Peak (4:45 PM - 5:45 PM) - Overall Peak Hour

All Classes (Lights, Articulated Trucks, Buses and Single-Unit Trucks, Pedestrians, Bicycles on Road)

All Movements

ID: 1080510, Location: 44.69804, -63.493034

Provided by: Trans4m Development Group

59 Craighburn Drive,

Dartmouth, NS, B2X 3E6, CA

[N] Montague Rd - SB

Total: 567

In: 383 Out: 184

89
77
217

[W] Main St. - EB
Total: 2719
In: 1763 Out: 956

123
1477
163

31
799
32
Out: 1709 In: 862
Total: 2571
[E] Main St. - WB

4
68
30
15

Out: 272 In: 113
Total: 385
[S] Hillsboro Dr. - NB

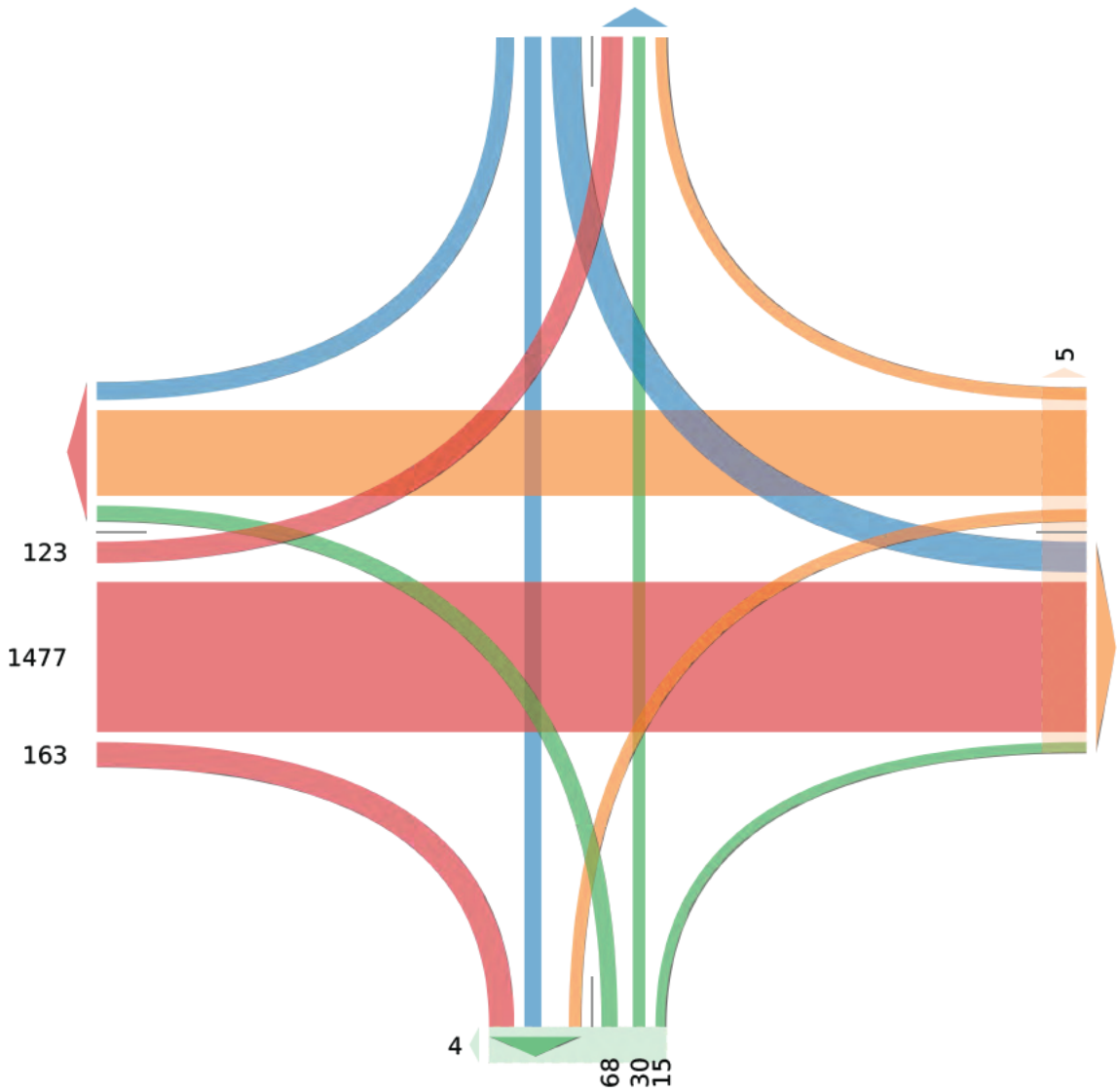

APPENDIX B

TRIP GENERATION

Data Plot and Equation

Caution – Small Sample Size

DATA STATISTICS

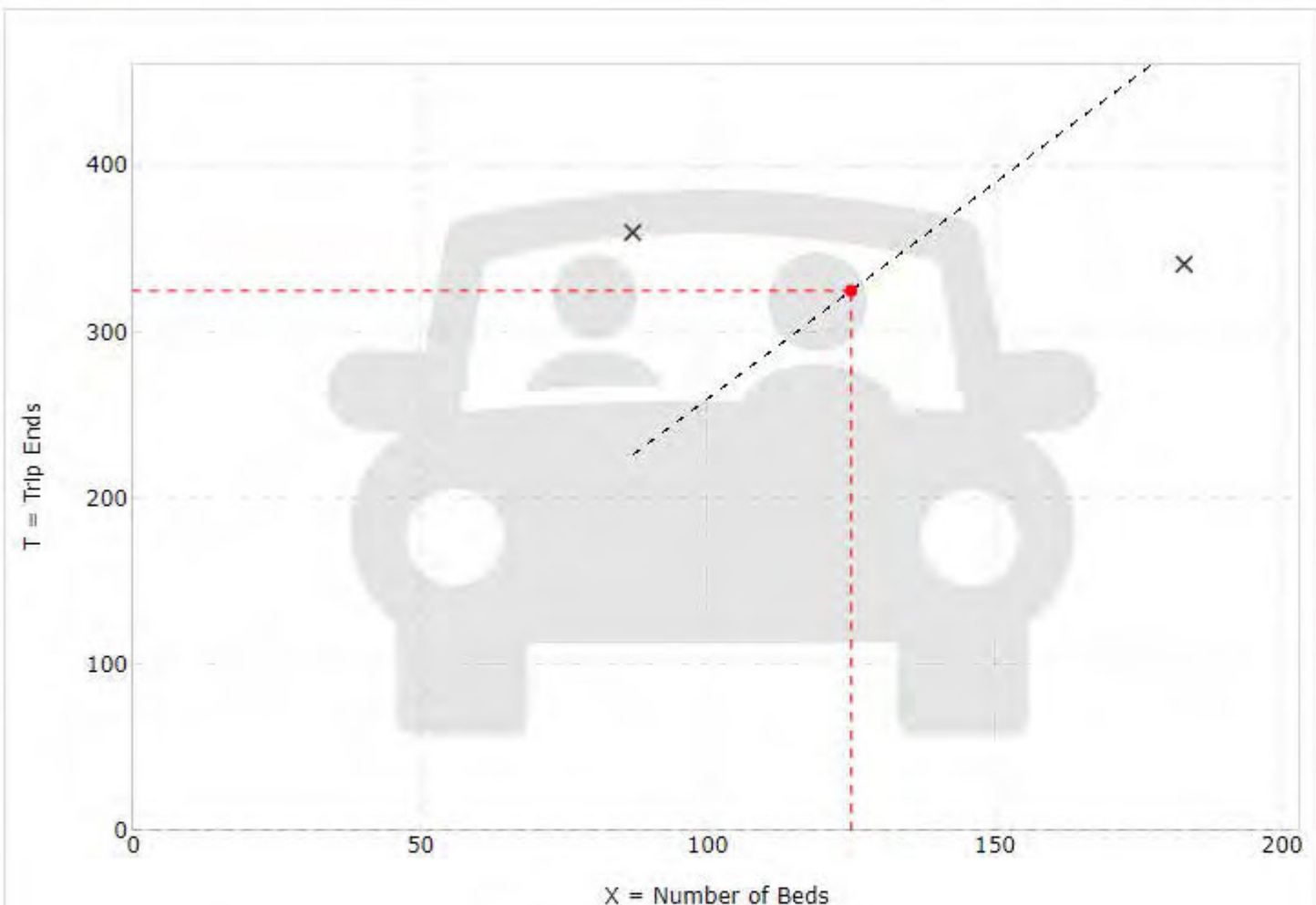

Reset Zoom Restore

X Study Site

- - - Average Rate

Land Use:
Assisted Living (254) Click for Description and Data Plots
Independent Variable:
Beds
Time Period:
Weekday
Setting/Location:
General Urban/Suburban
Trip Type:
Vehicle
Number of Studies:
2
Avg. Num. of Beds:
135
Average Rate:
2.60
Range of Rates:
1.86 - 4.14
Standard Deviation:

Fitted Curve Equation:
Not Given
R²:

Directional Distribution:
50% entering, 50% exiting
Calculated Trip Ends:
Average Rate: 325 (Total), 163 (Entry), 162 (Exit)

Use the mouse wheel to Zoom Out or Zoom In.
Hover the mouse pointer on data points to view X and T values.

Data Plot and Equation

DATA STATISTICS

Land Use:

Assisted Living (254) [Click for Description and Data Plots](#)

Independent Variable:

Beds

Time Period:

Weekday

Peak Hour of Adjacent Street Traffic

One Hour Between 7 and 9 a.m.

Setting/Location:

General Urban/Suburban

Trip Type:

Vehicle

Number of Studies:

14

Avg. Num. of Beds:

106

Average Rate:

0.18

Range of Rates:

0.08 - 0.29

Standard Deviation:

0.08

Fitted Curve Equation:

Not Given

R²:

Directional Distribution:

60% entering, 40% exiting

Calculated Trip Ends:

Average Rate: 23 (Total), 14 (Entry), 9 (Exit)

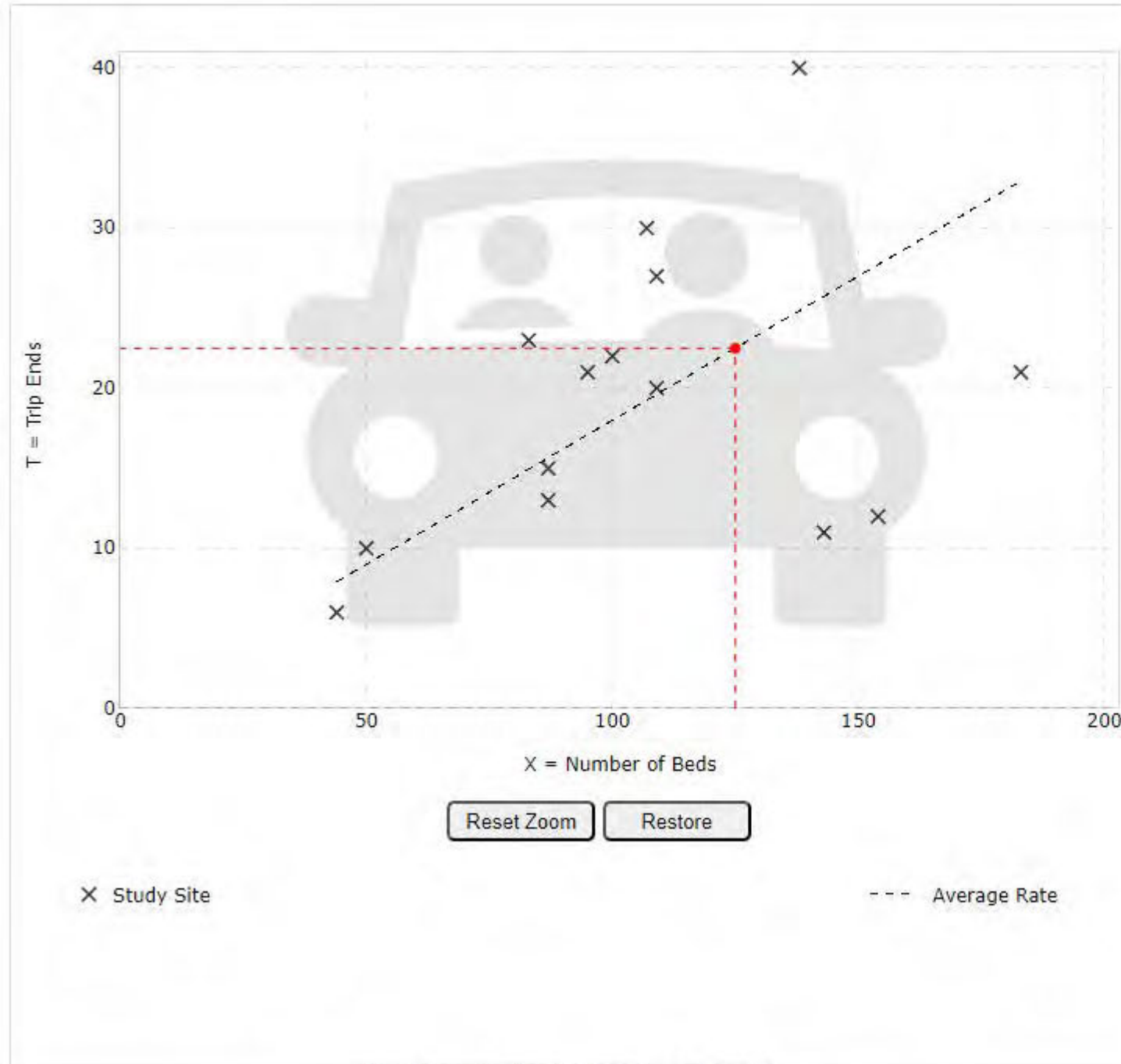

Use the mouse wheel to Zoom Out or Zoom In.
Hover the mouse pointer on data points to view X and T values.

Data Plot and Equation

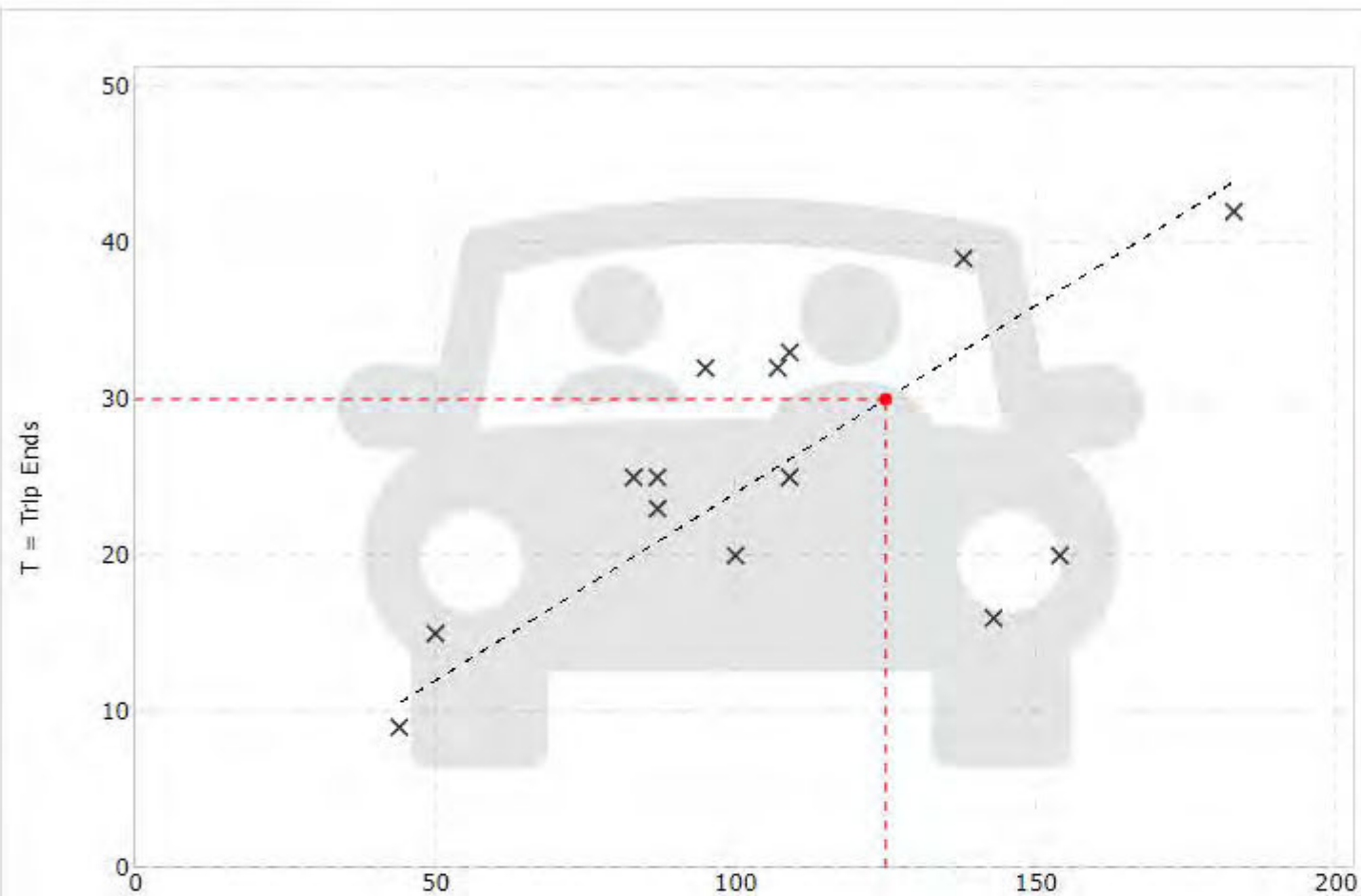

Reset Zoom Restore

x Study Site

- - - Average Rate

Use the mouse wheel to Zoom Out or Zoom In.
Hover the mouse pointer on data points to view X and T values.

DATA STATISTICS

Land Use:
Assisted Living (254) [Click for Description and Data Plots](#)

Independent Variable:
Beds

Time Period:
Weekday
Peak Hour of Adjacent Street Traffic
One Hour Between 4 and 6 p.m.

Setting/Location:
General Urban/Suburban

Trip Type:
Vehicle

Number of Studies:
14

Avg. Num. of Beds:
106

Average Rate:
0.24

Range of Rates:
0.11 - 0.34

Standard Deviation:
0.07

Fitted Curve Equation:
Not Given

R²:

Directional Distribution:
39% entering, 61% exiting

Calculated Trip Ends:
Average Rate: 30 (Total), 12 (Entry), 18 (Exit)

APPENDIX C

TRIP ASSIGNMENT

Development: Assisted Living

Driveway: 3 Montague DW

Origin #	Route	To		From	
		Distribution %	Trips	Distribution %	Trips
1	Montague DW to Montague North (9)	20.00	3	20.00	2
2	Montague DW to Hillsboro South (5001)	10.00	2	10.00	1
3	Montague DW to Main East (x)	30.00	5	30.00	3
4	Montague DW to Main West (x)	40.00	6	40.00	4

Development: Assisted Living

Driveway: 3 Montague DW

Origin #	Route	To		From	
		Distribution %	Trips	Distribution %	Trips
1	Montague DW to Montague North (9)	20.00	3	20.00	4
2	Montague DW to Hillsboro South (5001)	10.00	1	10.00	2
3	Montague DW to Main East (x)	30.00	4	30.00	6
4	Montague DW to Main West (x)	40.00	5	40.00	8

APPENDIX D

SYNCHRO REPORTS

Montague Assisted Living
5: Hillsboro/Montague & Main

2023 - Baseline
Timing Plan: AM Peak Hour



Lane Group	EBL	EBT	EBR	WBL	WBT	WBR	NBL	NBT	NBR	SBL	SBT	SBR
Lane Configurations	↖	↑↑	↗	↖	↑↑			↕			↕	
Traffic Volume (vph)	70	560	60	55	1200	190	70	50	5	25	35	80
Future Volume (vph)	70	560	60	55	1200	190	70	50	5	25	35	80
Satd. Flow (prot)	1770	3539	1583	1770	3465	0	0	1803	0	0	1704	0
Flt Permitted	0.090			0.367				0.757			0.934	
Satd. Flow (perm)	168	3539	1583	684	3465	0	0	1403	0	0	1606	0
Satd. Flow (RTOR)			78		34			2			76	
Lane Group Flow (vph)	76	609	65	60	1511	0	0	135	0	0	152	0
Turn Type	pm+pt	NA	Perm	pm+pt	NA		Perm	NA		Perm	NA	
Protected Phases	5	2		1	6			4				8
Permitted Phases	2		2	6			4			8		
Total Split (s)	10.0	49.0	49.0	10.0	49.0		25.0	25.0		25.0	25.0	
Total Lost Time (s)	3.5	2.4	2.4	4.5	2.4			4.5			4.5	
Act Effct Green (s)	52.0	46.6	46.6	50.0	46.6			20.5			20.5	
Actuated g/C Ratio	0.62	0.55	0.55	0.60	0.55			0.24			0.24	
v/c Ratio	0.33	0.31	0.07	0.13	0.78			0.39			0.34	
Control Delay	9.4	10.6	2.0	6.1	17.9			30.2			16.1	
Queue Delay	0.0	0.0	0.0	0.0	0.0			0.0			0.0	
Total Delay	9.4	10.6	2.0	6.1	17.9			30.2			16.1	
LOS	A	B	A	A	B			C			B	
Approach Delay		9.7			17.5			30.3			16.1	
Approach LOS		A			B			C			B	
Queue Length 50th (m)	4.0	27.0	0.0	3.3	95.7			18.8			10.2	
Queue Length 95th (m)	8.4	37.2	4.3	7.3	125.2			35.6			26.4	
Internal Link Dist (m)		374.6			257.8			222.8			185.1	
Turn Bay Length (m)	56.0		67.0	78.0								
Base Capacity (vph)	227	1963	912	478	1937			343			449	
Starvation Cap Reductn	0	0	0	0	0			0			0	
Spillback Cap Reductn	0	0	0	0	0			0			0	
Storage Cap Reductn	0	0	0	0	0			0			0	
Reduced v/c Ratio	0.33	0.31	0.07	0.13	0.78			0.39			0.34	

Intersection Summary

Cycle Length: 84
 Actuated Cycle Length: 84
 Offset: 0 (0%), Referenced to phase 2:EBTL and 6:WBTL, Start of Green
 Control Type: Pretimed
 Maximum v/c Ratio: 0.78
 Intersection Signal Delay: 15.8
 Intersection LOS: B
 Intersection Capacity Utilization 69.0%
 ICU Level of Service C
 Analysis Period (min) 15

Splits and Phases: 5: Hillsboro/Montague & Main

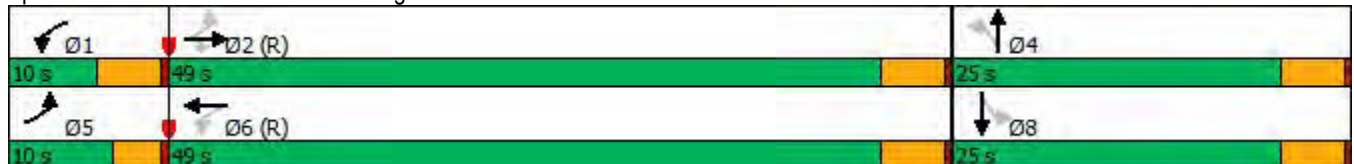

Montague Assisted Living
6: Montague & Driveway

2023 - Baseline
Timing Plan: AM Peak Hour



Movement	EBL	EBR	NBL	NBT	SBT	SBR
Lane Configurations						
Traffic Volume (veh/h)	0	0	0	250	170	0
Future Volume (Veh/h)	0	0	0	250	170	0
Sign Control	Stop			Free	Free	
Grade	0%			0%	0%	
Peak Hour Factor	0.92	0.92	0.92	0.92	0.92	0.92
Hourly flow rate (vph)	0	0	0	272	185	0
Pedestrians						
Lane Width (m)						
Walking Speed (m/s)						
Percent Blockage						
Right turn flare (veh)						
Median type				None	None	
Median storage veh						
Upstream signal (m)						
pX, platoon unblocked						
vC, conflicting volume	457	185	185			
vC1, stage 1 conf vol						
vC2, stage 2 conf vol						
vCu, unblocked vol	457	185	185			
tC, single (s)	6.4	6.2	4.1			
tC, 2 stage (s)						
tF (s)	3.5	3.3	2.2			
p0 queue free %	100	100	100			
cM capacity (veh/h)	562	857	1390			
Direction, Lane #	EB 1	NB 1	SB 1			
Volume Total	0	272	185			
Volume Left	0	0	0			
Volume Right	0	0	0			
cSH	1700	1390	1700			
Volume to Capacity	0.00	0.00	0.11			
Queue Length 95th (m)	0.0	0.0	0.0			
Control Delay (s)	0.0	0.0	0.0			
Lane LOS	A					
Approach Delay (s)	0.0	0.0	0.0			
Approach LOS	A					
Intersection Summary						
Average Delay	0.0					
Intersection Capacity Utilization	16.5%			ICU Level of Service	A	
Analysis Period (min)	15					

Montague Assisted Living
5: Hillsboro/Montague & Main

2033 - Development
Timing Plan: AM Peak Hour

Lane Group	EBL	EBT	EBR	WBL	WBT	WBR	NBL	NBT	NBR	SBL	SBT	SBR
Lane Configurations												
Traffic Volume (vph)	70	560	60	55	1200	190	70	50	5	25	35	80
Future Volume (vph)	93	683	73	67	1463	238	85	63	6	34	44	102
Satd. Flow (prot)	1770	3539	1583	1770	3465	0	0	1802	0	0	1706	0
Flt Permitted	0.090			0.304				0.668			0.927	
Satd. Flow (perm)	168	3539	1583	566	3465	0	0	1237	0	0	1596	0
Satd. Flow (RTOR)			79		35			2			74	
Lane Group Flow (vph)	101	742	79	73	1849	0	0	167	0	0	196	0
Turn Type	pm+pt	NA	Perm	pm+pt	NA		Perm	NA		Perm	NA	
Protected Phases	5	2		1	6			4				8
Permitted Phases	2		2	6			4			8		
Total Split (s)	10.0	49.0	49.0	10.0	49.0		25.0	25.0		25.0	25.0	
Total Lost Time (s)	3.5	2.4	2.4	4.5	2.4			4.5			4.5	
Act Effct Green (s)	52.0	46.6	46.6	50.0	46.6			20.5			20.5	
Actuated g/C Ratio	0.62	0.55	0.55	0.60	0.55			0.24			0.24	
v/c Ratio	0.44	0.38	0.09	0.18	0.95			0.55			0.44	
Control Delay	13.8	11.2	2.5	6.6	30.7			35.4			20.0	
Queue Delay	0.0	0.0	0.0	0.0	0.0			0.0			0.0	
Total Delay	13.8	11.2	2.5	6.6	30.7			35.4			20.0	
LOS	B	B	A	A	C			D			C	
Approach Delay		10.8			29.8			35.4			20.0	
Approach LOS		B			C			D			C	
Queue Length 50th (m)	5.4	34.4	0.0	4.0	142.6			24.3			16.9	
Queue Length 95th (m)	14.4	46.4	5.8	8.5	#207.3			44.9			36.6	
Internal Link Dist (m)		374.6			257.8			222.8			185.1	
Turn Bay Length (m)	56.0		67.0	78.0								
Base Capacity (vph)	227	1963	913	415	1937			303			445	
Starvation Cap Reductn	0	0	0	0	0			0			0	
Spillback Cap Reductn	0	0	0	0	0			0			0	
Storage Cap Reductn	0	0	0	0	0			0			0	
Reduced v/c Ratio	0.44	0.38	0.09	0.18	0.95			0.55			0.44	

Intersection Summary

Cycle Length: 84
 Actuated Cycle Length: 84
 Offset: 0 (0%), Referenced to phase 2:EBTL and 6:WBTL, Start of Green
 Control Type: Pretimed
 Maximum v/c Ratio: 0.95
 Intersection Signal Delay: 24.0 Intersection LOS: C
 Intersection Capacity Utilization 69.0% ICU Level of Service C
 Analysis Period (min) 15
 # 95th percentile volume exceeds capacity, queue may be longer.
 Queue shown is maximum after two cycles.

Splits and Phases: 5: Hillsboro/Montague & Main





Movement	EBL	EBR	NBL	NBT	SBT	SBR
Lane Configurations						
Traffic Volume (veh/h)	0	0	0	250	170	0
Future Volume (Veh/h)	2	10	16	305	207	4
Sign Control	Stop			Free	Free	
Grade	0%			0%	0%	
Peak Hour Factor	0.92	0.92	0.92	0.92	0.92	0.92
Hourly flow rate (vph)	2	11	17	332	225	4
Pedestrians						
Lane Width (m)						
Walking Speed (m/s)						
Percent Blockage						
Right turn flare (veh)						
Median type				None	None	
Median storage veh						
Upstream signal (m)						
pX, platoon unblocked						
vC, conflicting volume	593	227	229			
vC1, stage 1 conf vol						
vC2, stage 2 conf vol						
vCu, unblocked vol	593	227	229			
tC, single (s)	6.4	6.2	4.1			
tC, 2 stage (s)						
tF (s)	3.5	3.3	2.2			
p0 queue free %	100	99	99			
cM capacity (veh/h)	462	812	1339			
Direction, Lane #	EB 1	NB 1	SB 1			
Volume Total	13	349	229			
Volume Left	2	17	0			
Volume Right	11	0	4			
cSH	728	1339	1700			
Volume to Capacity	0.02	0.01	0.13			
Queue Length 95th (m)	0.4	0.3	0.0			
Control Delay (s)	10.0	0.5	0.0			
Lane LOS	B	A				
Approach Delay (s)	10.0	0.5	0.0			
Approach LOS	B					
Intersection Summary						
Average Delay			0.5			
Intersection Capacity Utilization			16.5%	ICU Level of Service	A	
Analysis Period (min)			15			

Montague Assisted Living
5: Hillsboro/Montague & Main

2023 - Baseline
Timing Plan: PM Peak Hour

Lane Group	EBL	EBT	EBR	WBL	WBT	WBR	NBL	NBT	NBR	SBL	SBT	SBR
Lane Configurations												
Traffic Volume (vph)	125	1480	165	35	800	35	70	30	15	220	80	90
Future Volume (vph)	125	1480	165	35	800	35	70	30	15	220	80	90
Satd. Flow (prot)	1770	3539	1583	1863	3518	0	0	1799	1583	0	1798	1583
Flt Permitted	0.178			0.106				0.546			0.715	
Satd. Flow (perm)	332	3539	1583	197	3518	0	0	1017	1583	0	1332	1583
Satd. Flow (RTOR)			174		6				115			61
Lane Group Flow (vph)	132	1558	174	38	908	0	0	109	16	0	326	98
Turn Type	pm+pt	NA	Perm	Perm	NA		Perm	NA	Perm	pm+pt	NA	Perm
Protected Phases	5	2			6			4		3		8
Permitted Phases	2		2	6			4		4	8		8
Total Split (s)	12.3	53.6	53.6	41.3	41.3		24.9	24.9	24.9	11.5	36.4	36.4
Total Lost Time (s)	3.5	2.4	2.4	4.5	2.4			4.5	4.5		4.5	4.5
Act Effct Green (s)	50.3	51.4	51.4	37.7	39.8			27.7	27.7		27.7	27.7
Actuated g/C Ratio	0.58	0.60	0.60	0.44	0.46			0.32	0.32		0.32	0.32
v/c Ratio	0.40	0.74	0.17	0.44	0.56			0.33	0.03		0.76	0.18
Control Delay	12.9	16.1	1.9	39.9	19.2			24.9	0.1		38.5	10.1
Queue Delay	0.0	0.0	0.0	0.0	0.0			0.0	0.0		0.0	0.0
Total Delay	12.9	16.1	1.9	39.9	19.2			24.9	0.1		38.5	10.1
LOS	B	B	A	D	B			C	A		D	B
Approach Delay		14.5			20.1			21.7			32.0	
Approach LOS		B			C			C			C	
Queue Length 50th (m)	10.8	107.0	0.0	4.9	63.9			14.1	0.0		50.0	4.4
Queue Length 95th (m)	19.6	136.4	8.3	#19.8	84.0			28.1	0.0		82.3	15.0
Internal Link Dist (m)		374.6			257.8			222.8			185.1	
Turn Bay Length (m)	56.0		67.0	78.0					15.0			15.0
Base Capacity (vph)	341	2114	1015	86	1630			333	596		496	627
Starvation Cap Reductn	0	0	0	0	0			0	0		0	0
Spillback Cap Reductn	0	0	0	0	0			0	0		0	0
Storage Cap Reductn	0	0	0	0	0			0	0		0	0
Reduced v/c Ratio	0.39	0.74	0.17	0.44	0.56			0.33	0.03		0.66	0.16

Intersection Summary

Cycle Length: 90

Actuated Cycle Length: 86

Control Type: Actuated-Uncoordinated

Maximum v/c Ratio: 0.76

Intersection Signal Delay: 18.5

Intersection LOS: B

Intersection Capacity Utilization 80.6%

ICU Level of Service D

Analysis Period (min) 15

95th percentile volume exceeds capacity, queue may be longer.

Queue shown is maximum after two cycles.

Splits and Phases: 5: Hillsboro/Montague & Main



Montague Assisted Living
6: Montague & Driveway

2023 - Baseline
Timing Plan: PM Peak Hour



Movement	EBL	EBR	NBL	NBT	SBT	SBR
Lane Configurations						
Traffic Volume (veh/h)	0	0	0	130	320	0
Future Volume (Veh/h)	0	0	0	130	320	0
Sign Control	Stop			Free	Free	
Grade	0%			0%	0%	
Peak Hour Factor	0.92	0.92	0.92	0.92	0.92	0.92
Hourly flow rate (vph)	0	0	0	141	348	0
Pedestrians						
Lane Width (m)						
Walking Speed (m/s)						
Percent Blockage						
Right turn flare (veh)						
Median type				None	None	
Median storage veh						
Upstream signal (m)						
pX, platoon unblocked						
vC, conflicting volume	489	348	348			
vC1, stage 1 conf vol						
vC2, stage 2 conf vol						
vCu, unblocked vol	489	348	348			
tC, single (s)	6.4	6.2	4.1			
tC, 2 stage (s)						
tF (s)	3.5	3.3	2.2			
p0 queue free %	100	100	100			
cM capacity (veh/h)	538	695	1211			
Direction, Lane #	EB 1	NB 1	SB 1			
Volume Total	0	141	348			
Volume Left	0	0	0			
Volume Right	0	0	0			
cSH	1700	1211	1700			
Volume to Capacity	0.00	0.00	0.20			
Queue Length 95th (m)	0.0	0.0	0.0			
Control Delay (s)	0.0	0.0	0.0			
Lane LOS	A					
Approach Delay (s)	0.0	0.0	0.0			
Approach LOS	A					
Intersection Summary						
Average Delay	0.0					
Intersection Capacity Utilization	20.2%			ICU Level of Service	A	
Analysis Period (min)	15					

Montague Assisted Living
5: Hillsboro/Montague & Main

2033 - Development
Timing Plan: PM Peak Hour



Lane Group	EBL	EBT	EBR	WBL	WBT	WBR	NBL	NBT	NBR	SBL	SBT	SBR
Lane Configurations	↘	↑↑	↗	↘	↑↑			↑	↗		↗	↗
Traffic Volume (vph)	125	1480	165	35	800	35	70	30	15	220	80	90
Future Volume (vph)	158	1804	201	43	975	48	85	38	18	275	100	119
Satd. Flow (prot)	1770	3539	1583	1863	3514	0	0	1801	1583	0	1798	1583
Flt Permitted	0.098			0.108				0.438			0.697	
Satd. Flow (perm)	183	3539	1583	201	3514	0	0	816	1583	0	1298	1583
Satd. Flow (RTOR)			185		7				115			61
Lane Group Flow (vph)	166	1899	212	47	1112	0	0	133	20	0	408	129
Turn Type	pm+pt	NA	Perm	Perm	NA		Perm	NA	Perm	pm+pt	NA	Perm
Protected Phases	5	2			6			4		3		8
Permitted Phases	2		2	6			4		4	8		8
Total Split (s)	12.3	53.6	53.6	41.3	41.3		24.9	24.9	24.9	11.5	36.4	36.4
Total Lost Time (s)	3.5	2.4	2.4	4.5	2.4			4.5	4.5		4.5	4.5
Act Effct Green (s)	50.1	51.2	51.2	37.2	39.3			31.9	31.9		31.9	31.9
Actuated g/C Ratio	0.56	0.57	0.57	0.41	0.44			0.35	0.35		0.35	0.35
v/c Ratio	0.66	0.94	0.22	0.57	0.72			0.46	0.03		0.89	0.21
Control Delay	27.5	29.5	2.6	52.1	24.2			28.8	0.1		50.9	12.3
Queue Delay	0.0	0.0	0.0	0.0	0.0			0.0	0.0		0.0	0.0
Total Delay	27.5	29.5	2.6	52.1	24.2			28.8	0.1		50.9	12.3
LOS	C	C	A	D	C			C	A		D	B
Approach Delay		26.9			25.3			25.1			41.6	
Approach LOS		C			C			C			D	
Queue Length 50th (m)	13.8	157.3	2.0	6.4	85.3			18.4	0.0		69.0	8.2
Queue Length 95th (m)	#37.4	#223.4	11.4	#24.8	110.1			36.7	0.0		#124.7	20.7
Internal Link Dist (m)		374.6			257.8			222.8			185.1	
Turn Bay Length (m)	56.0		67.0	78.0					15.0			15.0
Base Capacity (vph)	257	2013	980	83	1537			289	635		460	600
Starvation Cap Reductn	0	0	0	0	0			0	0		0	0
Spillback Cap Reductn	0	0	0	0	0			0	0		0	0
Storage Cap Reductn	0	0	0	0	0			0	0		0	0
Reduced v/c Ratio	0.65	0.94	0.22	0.57	0.72			0.46	0.03		0.89	0.21

Intersection Summary

Cycle Length: 90
 Actuated Cycle Length: 90
 Control Type: Actuated-Uncoordinated
 Maximum v/c Ratio: 0.94
 Intersection Signal Delay: 28.3
 Intersection LOS: C
 Intersection Capacity Utilization 80.6%
 ICU Level of Service D
 Analysis Period (min) 15
 # 95th percentile volume exceeds capacity, queue may be longer.
 Queue shown is maximum after two cycles.

Splits and Phases: 5: Hillsboro/Montague & Main





Movement	EBL	EBR	NBL	NBT	SBT	SBR
Lane Configurations						
Traffic Volume (veh/h)	0	0	0	130	320	0
Future Volume (Veh/h)	5	20	12	158	390	4
Sign Control	Stop			Free	Free	
Grade	0%			0%	0%	
Peak Hour Factor	0.92	0.92	0.92	0.92	0.92	0.92
Hourly flow rate (vph)	5	22	13	172	424	4
Pedestrians						
Lane Width (m)						
Walking Speed (m/s)						
Percent Blockage						
Right turn flare (veh)						
Median type				None	None	
Median storage veh						
Upstream signal (m)						
pX, platoon unblocked						
vC, conflicting volume	624	426	428			
vC1, stage 1 conf vol						
vC2, stage 2 conf vol						
vCu, unblocked vol	624	426	428			
tC, single (s)	6.4	6.2	4.1			
tC, 2 stage (s)						
tF (s)	3.5	3.3	2.2			
p0 queue free %	99	96	99			
cM capacity (veh/h)	444	628	1131			
Direction, Lane #	EB 1	NB 1	SB 1			
Volume Total	27	185	428			
Volume Left	5	13	0			
Volume Right	22	0	4			
cSH	584	1131	1700			
Volume to Capacity	0.05	0.01	0.25			
Queue Length 95th (m)	1.2	0.3	0.0			
Control Delay (s)	11.5	0.7	0.0			
Lane LOS	B	A				
Approach Delay (s)	11.5	0.7	0.0			
Approach LOS	B					
Intersection Summary						
Average Delay			0.7			
Intersection Capacity Utilization			20.2%	ICU Level of Service	A	
Analysis Period (min)			15			