

| | TITLE | SECTION | REVISION DATE | PAGE NUM. |
|-----|---|--------------|---------------|-----------|
| 1. | Definitions | 00 71 00 | JAN. 2023 | 2 |
| 2. | General Conditions of the Civil Works Contract | 00 72 45 | JAN. 2023 | 5 |
| 3. | Measurement and Payment | 01 22 00 | JAN. 2024 | 33 |
| 4. | Specification for Hot Mix Asphalt Concrete | S-1 | JAN. 2024 | 108 |
| 5. | Specification for Performance Graded Asphalt Binder | S-2 | JAN. 2020 | 138 |
| 6. | Asphaltic Concrete and Portland Cement Concrete Planing / Profiling | S-3 | JAN. 2024 | 146 |
| 7. | Pavement Markings | S-4 | JAN. 2020 | 150 |
| 8. | Micro-Surfacing | S-5 | JAN. 2021 | 156 |
| 9. | Traffic Control Manual Supplement | Appendix 'A' | JAN. 2024 | 167 |
| 10. | Lighting Equipment | 26 50 00 | JUN. 2019 | 186 |
| 11. | Pre-cast Segmental Retaining Wall System | 32 32 23 | JAN. 2021 | 194 |
| 12. | Planting of Trees, Shrubs and Groundcover | 32 90 00 | JAN. 2024 | 200 |
| 13. | Structural Soil Cells | 32 94 50 | JAN. 2024 | 215 |
| 14. | Traffic Signal Systems | 34 41 13 | JAN. 2022 | 225 |
| 15. | Standard Details | 39 00 00 | JAN. 2024 | 249 |
| 16. | Contractor Safety Management Policy | | MAR. 2021 | 332 |

The following Definitions shall apply to all Contract Documents:

1. **Changes in the Work**

Changes in the Work means the deletion, extension, increase, decrease or alteration of lines, grades, dimensions, methods, drawings or materials of the Work or part thereof, within the scope of the Work contemplated by the Contract Documents.

2. **Completion Time**

The Completion Time is the time stipulated in the Contract Documents for Substantial Performance of the Work.

3. **Contract**

The Contract means the undertaking by the parties to perform their respective duties, responsibilities and obligations as prescribed in the Contract Documents and represents the entire agreement between the parties. The Contract may be amended only as provided in the General Conditions of the Civil Works Contract.

4. **Contract Documents**

Contract Documents means the executed Form of Agreement between the Owner and Contractor, the General Conditions of the Civil Works Contract, the Supplementary General Conditions, the Definitions, the Standard Specifications for Municipal Services, Part II, the Supplementary Specifications, the Drawings, the Instructions to Bidders, the Bid Form and such other documents as are listed in the Table of Contents including amendments or addenda thereto incorporated before the execution of the Form of Agreement and subsequent amendments or addenda thereto made pursuant to the provisions of the Contract and agreed upon between the parties.

5. **Contractor**

The Contractor means the person, firm or corporation identified as such in the Form of Agreement and is referred to throughout the Contract Documents as if singular in number. The term Contractor means the Contractor or authorized representative as designated to the Owner in writing.

6. **Engineer**

The Engineer means the Executive Director of Public Works for the Halifax Regional Municipality or their authorized representative.

7. **Engineer's Representative**

Engineer's Representative means a person, firm or corporation appointed from time to time by the Engineer under GC3-ENGINEER.

8. Extra Work

Extra Work means any work or service, the performance of which is beyond the scope of the Work contemplated by the Contract Documents.

9. Other Contractor

Other Contractor means a person, firm or corporation employed by or having a separate contract directly or indirectly with the Owner for work other than that required by the Contract Documents.

10. Owner

The Owner means the Halifax Regional Municipality. The term Owner means the Owner or authorized agent or representative as designated to the Contractor in writing but does not include the Engineer.

11. Place of the Work

The Place of the Work means the designated site or location of the Project of which the Work may be the whole or a part.

12. Products

Products mean material, machinery, equipment, and fixtures forming the Work but does not include machinery and equipment used for preparation, fabrication, conveying, and erection of the Work and normally referred to as construction machinery and equipment.

13. Project

The Project means the total construction contemplated of which the Work may be the whole or a part.

14. Subcontractor

A Subcontractor means a person, firm or corporation having a direct contract with the Contractor to perform a part or parts of the Work, or to supply products worked to a special design according to the Contract Documents but does not include one who merely supplies products not so worked. The term Subcontractor is referred to throughout the Contract Documents as if singular in number.

15. Substantial Performance of the Work

Substantial Performance of the Work is as defined in the lien legislation applicable in the Province of Nova Scotia. If such legislation is not in force or does not contain such definition, Substantial Performance of the work shall have been reached when the Work is ready for use or is being used for the purpose intended and is so certified by the Engineer.

16. Total Performance of the Work

Total Performance of the Work means the entire Work, except those items arising from the provisions of Section 00 72 45, subsection 25 - WARRANTY, has been performed to the requirements of the Contract Documents and is so certified by the Engineer.

17. Work

Work means the total construction and related services required by the Contract Documents and to be performed by the Contractor.

18. Working Day

Working Day means a day other than a Saturday, Sunday, statutory holiday, or statutory vacation day that is observed by the construction industry in the area of the Place of the Work.

**** End 00 71 00 ****

INDEX TO CLAUSES

| | |
|-------|---|
| GC 1 | Documents |
| GC 2 | Additional Instructions |
| GC 3 | Engineer |
| GC 4 | Delays |
| GC 5 | Suspension of Work |
| GC 6 | Owners Right to Terminate Contract and Perform Work |
| GC 7 | Contractors Right to Stop Work or Terminate the Contract |
| GC 8 | Disputes |
| GC 9 | Assignment |
| GC 10 | Other Contractors |
| GC 11 | Subcontractors |
| GC 12 | Changes in the Work and Extra Work |
| GC 13 | Valuation and Certification of Changes in the Work and Extra Work |
| GC 14 | Applications for Payment |
| GC 15 | Certificates and Payments |
| GC 16 | Taxes and Duties |
| GC 17 | Laws, Notices, Permits and Fees |
| GC 18 | Patent Rights and Royalties |
| GC 19 | Workers Compensation Insurance |
| GC 20 | Indemnification |
| GC 21 | Insurance |
| GC 22 | Protection of Work and Property |
| GC 23 | Damages and Mutual Responsibility |
| GC 24 | Security |
| GC 25 | Warranty |
| GC 26 | Contractor's Responsibility and Control of Work |
| GC 27 | Superintendence |
| GC 28 | Labour and Products |
| GC 29 | Subsurface Conditions |
| GC 30 | Use of the Work |
| GC 31 | Inspection of the Work |
| GC 32 | Rejected Work |
| GC 33 | Products Supplied by Owner |
| GC 34 | Liquidated Damages |
| GC 35 | Hours and Days of Work |
| GC 36 | Land |
| GC 37 | Order to Start Work |
| GC 38 | Setting Out the Work |
| GC 39 | Local Office and Telephone Numbers |
| GC 40 | Time for Completion |
| GC 41 | Vendor Performance Evaluation |

GC 1 DOCUMENTS

- 1.1 The Form of Agreement shall be signed in duplicate by the Owner and the Contractor.
- 1.2 The intent of the Contract Documents is to describe the labour, products, and services necessary for the performance of the Work. It is not intended, however, that the Contractor shall supply products or perform Work not consistent with, covered by, or properly inferable from the Contract Documents.
- 1.3 Words and abbreviations which have well-known technical or trade meanings are used in the Contract Documents in accordance with such recognized meanings.
- 1.4 References to the singular shall be considered to include the plural, and references to the masculine shall be considered to include the feminine, or body corporate, as the context requires.
- 1.5 The language in the Contract Documents shall be interpreted as to its fair meaning and not strictly for or against any party. Any rule of construction to the effect that ambiguities are to be resolved against the drafting party (i.e. – “contra proferentem”) shall not apply in interpreting the Contract Documents, as the Contract Documents shall be construed as having been co-authored by the parties.
- 1.6 If there is a conflict within the Contract Documents:
 - (a) The order of priority of documents, from highest to lowest, shall be
 - The Form of Agreement between the Owner and the Contractor,
 - The Definitions,
 - The Supplementary General Conditions,
 - The General Conditions of the Civil Works Contract,
 - The Supplementary Specifications,
 - The Drawings,
 - The Bid Form,
 - Summary Sheet,
 - Instructions to Bidders,
 - The Standard Specifications for Municipal Services, Part II.
 - (b) Drawings of larger scale shall govern over those of smaller scale of the same date.
 - (c) Dimensions shown on Drawings shall govern over dimensions scaled from Drawings.
 - (d) Later dated documents shall govern over earlier documents of the same type.
- 1.7 The Contractor will be provided without charge electronic copies of the Contract Documents as are necessary for the performance of the Work.
- 1.8 The Contractor shall keep one copy of the current Contract Documents and shop drawings at the Place of the Work, in good order and available to the Engineer and the Engineer’s representatives. This requirement shall not be considered to include the executed set of Contract Documents.

- 1.9 Drawings, specifications, models, and copies thereof furnished by the Engineer are and shall remain the property of the Engineer with the exception of the signed contract sets belonging to each party to this Contract. Such documents and models are to be used only with respect to the Work and are not to be used on other work. Such documents and models are not to be copied or revised in any manner without the written authorization of the Engineer.
- 1.10 Models furnished by the Contractor at the Owner's expense are the property of the Owner.

GC 2 ADDITIONAL INSTRUCTIONS

- 2.1 During the progress of the Work the Engineer will furnish to the Contractor such additional instructions to supplement the Contract Documents as may be necessary for the performance of the Work. Such instructions shall be consistent with the intent of the Contract Documents.
- 2.2 Additional instructions may be in the form of specifications, drawings, samples, models, or other written instructions.
- 2.3 Additional instructions will be issued by the Engineer with reasonable promptness and in accordance with a schedule agreed upon for such instructions.

GC 3 ENGINEER

- 3.1 The Engineer will provide administration of this Contract as described in the Contract Documents.
- 3.2 The Engineer will be the Owner's representative during construction and until completion of any correction of defects under the provisions of GC 25 - WARRANTY, Subsection 25.2 or until all required Work is performed completely, whichever is later. The Owner's instructions to the Contractor shall be forwarded through the Engineer. The Engineer will have authority to act on behalf of the Owner only to the extent provided in the Contract Documents.
- 3.3 The Engineer will not be responsible for and will not have control or charge of construction means, methods, techniques, sequences (unless otherwise directed by the Engineer), or procedures. The Engineer will not be responsible for or have control or charge over the acts or omissions of the Contractor, Subcontractors, or their agents, employees, or other persons performing any of the Work.
- 3.4 The Engineer will visit the Place of the Work at intervals appropriate to the progress of construction to become familiar with the progress and quality of the Work and to record the data necessary to establish the pay quantities under the Schedule of Quantities and Unit Prices.
- 3.5 Based on the Engineer's observations and evaluation of the Contractor's applications for payment, the Engineer will determine the amounts owing to the Contractor under the Contract and will issue certificates for payment in such amounts, as provided in the AGREEMENT and GC 15 - CERTIFICATES AND PAYMENTS.

- 3.6 The Engineer will be, in the first instance, the interpreter of the requirements of the Contract Documents and the judge of the performance there under by both parties to the Contract.
- Interpretations and decisions of the Engineer shall be consistent with the intent of the Contract Documents.
- 3.7 Claims, disputes, and other matters in question relating to the performance of the Work or the interpretation of the Contract Documents shall be referred initially to the Engineer in writing for decision which will be given in writing within a reasonable time.
- 3.8 The Engineer will have authority to reject Work which does not conform to the requirements of the Contract Documents. Whenever it is necessary or advisable the Engineer will have authority to require special inspection or testing of Work whether or not such Work be then fabricated, installed, or completed. However, neither the Engineer's authority to act nor any decision either to exercise or not to exercise such authority shall give rise to any duty or responsibility of the Engineer to the Contractor, Subcontractors, or their agents, employees, or other persons performing any of the Work.
- 3.9 The Engineer will review and take appropriate action upon the Contractor's submittals, such as shop drawings, product data, and samples, in accordance with the requirements of the Contract Documents.
- 3.10 The Engineer will prepare change orders in accordance with the requirements of GC 12 - CHANGES IN THE WORK AND EXTRA WORK.
- 3.11 The Engineer will conduct inspections to determine the date of Substantial Performance of the Work and the date when all required Work is performed completely in accordance with the requirements of GC 15 - CERTIFICATES AND PAYMENT and will receive equipment, system or material warranties, and related documents required by the Contract and provided by the Contractor.
- 3.12 The Engineer may provide at the site one or more representatives. The Engineer's Representative shall be responsible to the Engineer and shall carry out such duties and exercise such authority as may be delegated by the Engineer under 3.13.
- 3.13 The Engineer may from time-to-time delegate to the Engineer's Representative any of the duties and authorities vested in the Engineer and may at any time revoke such delegation. Any such delegation or revocation shall be in writing and shall not take effect until a copy thereof has been delivered to the Owner and the Contractor.
- 3.14 Any communication given by the Engineer's Representative to the Contractor in accordance with such delegation shall have the same effect as though it had been given by the Engineer, provided that:
- (a) any failure of the Engineer's Representative to disapprove any Work, materials or plant shall not prejudice the authority of the Engineer to disapprove such Work, materials, or plant and to give instructions for the rectification thereof;

- (b) if the Contractor questions any communication of the Engineer's Representative, the Contractor may refer the matter to the Engineer who shall confirm, reverse, or vary the contents of such communication.
- 3.15 In the event of the termination of the employment of the Engineer, the Owner shall immediately appoint an Engineer whose status under the Contract shall be that of the former Engineer.
- 3.16 Nothing contained in the Contract Documents shall create any contractual relationship between the Engineer and the Contractor, Subcontractors, suppliers, or their agents, employees, or other persons performing any of the Work.

GC 4 DELAYS

- 4.1 If the Contractor is delayed in the performance of the Work by an act or omission of the Owner, Engineer, Other Contractor, or anyone employed or engaged by them directly or indirectly, contrary to the provisions of the Contract Documents, then the Completion Time shall be extended for such reasonable time as the Engineer may decide in consultation with the Contractor. The Contractor shall be reimbursed by the Owner for reasonable costs incurred by the Contractor as a result of such delay, but excluding any consequential, indirect or special damages, loss of profit, loss of opportunity or loss of productivity resulting from such delay.
- 4.2 If the Contractor is delayed in the performance of the Work by a Stop Work Order issued by a court or other public authority, and providing that such order was not issued as the result of an act or fault of the Contractor or anyone employed or engaged directly or indirectly by the Contractor, then the Completion Time shall be extended for such reasonable time as the Engineer may decide in consultation with the Contractor. The Contractor shall be reimbursed by the Owner for reasonable costs incurred by the Contractor as a result of such delay, but excluding any consequential, indirect or special damages, loss of profit, loss of opportunity or loss of productivity resulting from such delay.
- 4.3 If the Contractor is delayed in the performance of the Work by labour disputes, strikes, lock-outs (including lock-outs decreed or recommended for its members by a recognized contractors' association, of which the Contractor is a member or to which the Contractor is otherwise bound), fire, unusual delay by common carriers or unavoidable casualties or, without limit to any of the foregoing, by a cause beyond the Contractor's control, then the Completion Time shall be extended for such reasonable time as the Engineer may decide in consultation with the Contractor, but in no case shall the extension of time be less than the time lost as the result of the event causing the delay, unless such shorter extension be agreed to by the Contractor. The Contractor shall not be entitled to payment for costs incurred as the result of such delays.
- 4.4 No extension shall be made for delay unless written notice of claim is given by the Contractor to the Engineer no later than seven (7) days after the commencement of delay, providing however, that in the case of a continuing cause of delay only one notice of claim shall be necessary.
- 4.5 If no additional instruction is made under GC 2 - ADDITIONAL INSTRUCTIONS, no claim by the Contractor for delay shall be allowed because of failure of the Engineer to furnish instructions until ten (10) days after a demand for such instructions has been made and not then unless such claim is reasonable.

- 4.6 The Engineer will not, except by written notice to the Contractor, stop or delay the Work pending instructions or proposed changes in the Work.
- 4.7 Notwithstanding any of the above paragraphs or any other provision in the Contract Documents, the Contractor shall not be reimbursed by the Owner for any costs incurred as a result of any delay unless the delay exceeds three (3) working days.

GC 5 SUSPENSION OF WORK

- 5.1 The Engineer may, by a written order, at any time suspend any part of the Work, or direct any portion to be commenced or completed in priority to any other part or portion.
- 5.2 Under no circumstances will the Contractor be entitled to any consequential, indirect, or special damages, loss of profit, loss of opportunity or loss of productivity resulting from a suspension order, and the Contractor shall not be reimbursed by the Owner for any costs of any kind incurred as a result of any suspension order unless the period of suspension exceeds three (3) working days.
- 5.3 When, for any reason, it is necessary to discontinue the Work, or any part thereof, the Contractor must, on notice from the Engineer, forthwith place the Work in proper and satisfactory condition for the accommodation of the public and for its effectual protection against damage from rain, snow, frost, ice, or other causes and must so maintain it.

GC 6 OWNER'S RIGHT TO TERMINATE CONTRACT AND PERFORM WORK

- 6.1 If the Contractor should be adjudged bankrupt, or makes a general assignment for the benefit of creditors because of insolvency or if a receiver is appointed because of insolvency, the Owner may, without prejudice to any other right or remedy, by giving the Contractor or receiver or trustee in bankruptcy written notice, terminate the Contract.
- 6.2 If the Contractor should neglect to perform the Work properly or otherwise fails to comply with the requirements of the Contract to a substantial degree and if the Engineer has given a written statement to the Owner and Contractor that sufficient cause exists, the Owner may notify the Contractor in writing that the Contractor is in default of contractual obligations and issue instructions to correct the default in the five (5) working days immediately following the receipt of such notice.
- 6.3 If the correction of the default cannot be completed in the five (5) working days specified, the Contractor shall be in compliance with the Owner's instructions if the Contractor:
- (a) commences the correction of the default within the specified time, and
 - (b) provides the Owner with an acceptable schedule for such correction, and
 - (c) completes the correction in accordance with such schedule.
- 6.4 If the Contractor fails to correct the default in the time specified or subsequently agreed upon the Owner, without prejudice to any other right or remedy, may:
- (a) correct such default and deduct the cost thereof from any payment then or thereafter due the Contractor provided the Engineer has certified such cost to the Owner and the Contractor, or

- (b) terminate the Contractor's right to continue with the Work in whole or in part or terminate the Contract.
- 6.5 If the Owner terminates the Contractor's right to continue with the Work under the conditions set out above, the Owner shall:
- (a) be entitled to take possession of the premises and products, and utilize the construction machinery and equipment subject to the rights of third parties, and finish the Work expediently,
- (b) withhold further payments to the Contractor until the Work is finished, and
- (c) when all required Work is performed completely, charge the Contractor the amount by which the full cost of finishing the Work as certified by the Engineer, including compensation to the Engineer for additional services, exceeds the unpaid balance of the Contract Price.
- 6.6 If surety bonds have been provided by the Contractor, the provisions of this General Condition shall be exercised in accordance with the conditions of such surety bonds.
- 6.7 The Contractor's obligation under the Contract as to quality, correction and warranty of the Work performed up to the time of termination shall continue in force after such termination.
- 6.8 In addition to its right to terminate the Contract set out herein, the Owner may terminate this Contract at any time for any other reason and without cause upon giving the Contractor Notice in Writing to that effect. In such event, the Contractor shall be entitled to be paid for all Work performed including reasonable profit, for loss sustained upon Products and Construction Equipment, and such other damages as the Contractor may have sustained as a result of the termination of the Contract, but in no event shall the Contractor be entitled to be compensated for any loss of profit on unperformed portions of the Work, or indirect, special, or consequential damages incurred.

GC7 CONTRACTOR'S RIGHT TO STOP THE WORK OR TERMINATE THE CONTRACT

- 7.1 If the Owner should be adjudged bankrupt or makes a general assignment for the benefit of creditors because of insolvency or if a receiver is appointed because of insolvency, the Contractor may, without prejudice to any other right or remedy available, by giving the owner or receiver or trustee in bankruptcy written notice, terminate the Contract.
- 7.2 If the Work should be stopped or otherwise delayed for a period of thirty (30) days or more under an order of a court or other public authority and providing that such order was not issued as the result of an act or fault of the Contractor or of anyone directly or indirectly employed or engaged by the Contractor, the Contractor may, without prejudice to any other right or remedy available, by giving the Owner written notice, terminate the Contract.
- 7.3 The Contractor may notify the Owner in writing, with a copy to the Engineer, that the Owner is in default of contractual obligations if:
- (a) the Engineer fails to issue a certificate in accordance with the provisions of GC 15-CERTIFICATES AND PAYMENT, or
- (b) the Owner fails to pay the Contractor when due the amounts certified by the Engineer or awarded by arbitration or court, or

- (c) the owner materially violates the requirements of the Contract to a substantial degree.

The Contractor's written notice to the Owner shall advise that if the default is not corrected in the five (5) working days immediately following the receipt of the written notice the Contractor may, without prejudice to any other right or remedy, stop the Work or terminate the Contract.

- 7.4 If the Contractor terminates the Contract under the conditions set out above, the Contractor shall be entitled to be paid for all Work performed in accordance with the Schedule of Quantities and Unit Prices to be mutually agreed to by both parties or where agreement cannot be reached, then the matter shall be settled in accordance with the provisions of GC 8 - DISPUTES.

GC 8 DISPUTES

- 8.1 Differences between the parties to the Contract as to the interpretation, application or administration of this Contract, or any failure to agree where agreement between the parties is called for, herein collectively called disputes, which are not resolved in the first instance by decision of the Engineer pursuant to the provisions of GC 3 - ENGINEER, subsections 3.6 and 3.7, shall be settled in accordance with the requirements of this General Condition.
- 8.2 The claimant shall give written notice of such dispute to the other party no later than twenty (20) days after the receipt of the Engineer's decision given under GC 3 - ENGINEER, paragraph 3.7. Such notice shall set forth the particulars of the matters in dispute, the probable extent and value of the damage and the relevant provisions of the Contract Documents. The other party shall reply to such notice within twenty-one (21) days after receiving it, setting out in such reply the grounds and other relevant provisions of the Contract Documents.
- 8.3 If the matter in dispute is not resolved promptly the Engineer will give such instructions as are necessary for the proper performance of the Work and to prevent delays pending settlement of the dispute. The parties shall act immediately according to such instructions, it being understood that by so doing neither party will jeopardize any claim he may have. If it is subsequently determined that such instructions were in error or at variance with the Contract Documents, the Owner shall pay the Contractor extra costs incurred by the Contractor in carrying out such instructions.
- 8.4 It is agreed that no act by either party shall be construed as a renunciation or waiver of any rights for recourse, provided the notices were given in accordance with subsection 8.2 and instructions were carried out as provided in subsection 8.3.
- 8.5 If the parties agree to submit disputes to arbitration, then the dispute shall be submitted to arbitration in accordance with the provisions of the Nova Scotia Commercial Arbitration Act.
- 8.6 If no provision or agreement is made for arbitration then either party may submit the dispute to a court of competent jurisdiction in the Province of Nova Scotia, as the circumstances may require.

- 8.7 In recognition of the obligation by the Contractor to perform the disputed Work as provided in paragraph 8.3, it is agreed that settlement of dispute proceedings may be commenced immediately following the dispute in accordance with the foregoing settlement of dispute procedures.

GC 9 ASSIGNMENT

- 9.1 Neither party to the Contract shall assign the Contract or a portion thereof without the written consent of the other, which consent shall not be unreasonably withheld.
- 9.2 The Contract shall be binding upon and shall inure to the benefit of the parties and their heirs, executors, administrators, successors and permitted assigns.

GC 10 OTHER CONTRACTORS

- 10.1 The Owner reserves the right to enter separate contracts in connection with the Project of which the Work is a part, or do certain Work by its own forces.
- 10.2 When separate contracts are awarded for different parts of the Project, or Work is performed by the Owner's own forces, the Owner shall:
- (a) provide for the co-ordination of the Work of its own forces and of each separate contract with the Work of this Contract, and
 - (b) ensure that insurance coverage is provided to the same requirements as are called for in GC 21 - INSURANCE. Such insurance shall be coordinated with the insurance coverage of the Contractor as it affects the Work of this Contract.
- 10.3 The Contractor shall co-ordinate the Work of this Contract with the Work of Other Contractors and the Owner's forces and connect as specified or shown in the Contract Documents. If there is a change in the scope of the Work required for the planning and performance of this co-ordination and connection, the changes shall be authorized in accordance with GC 12 - CHANGES IN THE WORK AND EXTRA WORK, and the value of the changes shall be determined in accordance with GC 13 - VALUATION AND CERTIFICATION OF CHANGES IN THE WORK AND EXTRA WORK.
- 10.4 The Contractor shall report to the Engineer any apparent deficiencies in the Work of Other Contractors or Owner's forces which would affect the Work of this Contract immediately as they come to the Contractor's attention and shall confirm such report in writing. Failure by the Contractor to report as required shall invalidate any claims against the Owner by reason of the deficiencies of Work of Owner's forces or Other Contractors.
- 10.5 The Owner shall take all reasonable precautions to avoid disputes on the Project arising from the Work of Other Contractors or own forces.

GC 11 SUBCONTRACTORS

- 11.1 The Contractor agrees to preserve and protect the rights of the parties under the Contract with respect to Work to be performed under subcontract and to:
- (a) enter into contracts or written agreements with Subcontractors to require them to perform their Work in accordance with and subject to the terms and conditions of the Contract Documents, and
 - (b) be as fully responsible to the Owner for acts and omissions of Subcontractors and of persons directly or indirectly employed by them as for acts and omissions of persons directly employed by the Contractor.

The Contractor therefore agrees to incorporate the terms and conditions of the Contract Documents into all sub-contract agreements entered into with Subcontractors.

- 11.2 The Contractor agrees to employ those Subcontractors proposed in writing at the time of the bid submission and accepted by the Owner.
- 11.3 The Owner may, for reasonable cause, object to the use of a proposed Subcontractor and require the Contractor to employ another person or firm as Subcontractor.
- 11.4 In the event that the Owner requires a change from a proposed Subcontractor, the Contract Price shall be adjusted by the difference in cost and mark-up occasioned by such required change.
- 11.5 The Contractor shall not be required to employ as a Subcontractor a person or firm to whom the Contractor may reasonably object.
- 11.6 The Engineer may, upon reasonable request, provide to a Subcontractor information as to the percentage or quantity of the Subcontractor's Work which has been certified for payment.
- 11.7 Nothing contained in the Contract Documents shall create a contractual relationship between a Subcontractor and the Owner.

GC 12 CHANGES IN THE WORK AND EXTRA WORK**12.1 Changes in The Work:**

Except as provided in GC 13 - VALUATION AND CERTIFICATION OF CHANGES IN THE WORK AND EXTRA WORK paragraph 13.4:

- (a) the Owner, through the Engineer, without invalidating the Contract, may by written order, make Changes in the Work with the Contract Price and Completion Time being adjusted accordingly and
- (b) no Changes in the Work shall proceed without a written order signed by the Owner and no claim for a change in the Contract Price or change in the Completion Time shall be valid unless so ordered, and at the same time valued or agreed to be valued as provided in GC 13 - VALUATION AND CERTIFICATION OF CHANGES IN THE WORK AND EXTRA WORK.

12.2 Extra Work:

- (a) The Owner may offer the Contractor Extra Work. If the terms and conditions for the performance of the Extra Work are agreed upon, the Owner, through the Engineer, shall
- issue a written change order amending the Contract Price and Completion Time as appropriate, or a written order to proceed until a price and change in time are agreed upon by the parties and a change order can be issued.

GC 13 VALUATION AND CERTIFICATION OF CHANGES IN THE WORK AND EXTRA WORK

- 13.1 If the type of work involved in a Change in the Work is included in the items contained in the Schedule of Quantities and Unit Prices, it shall be performed on the same payment basis as the original Work except as described in paragraphs 13.7 and 13.8, and the Completion Time shall be extended for such time as the Engineer may decide in consultation with the Contractor.
- 13.2 If the type of work involved in a Change in the Work is not included in the items contained in the Schedule of Quantities and Unit Prices, or is such as to alter the nature or intent of the Work included in this Schedule the value of such change shall be determined in one or more of the following methods.
- (a) by estimate and acceptance in a lump sum;
- (b) by unit prices agreed upon;
- (c) by cost and a fixed or percentage fee;
- (d) by variation of the Contract Unit Prices.
- 13.3 When a Change in the Work covered by paragraph 13.2 is proposed or required the Contractor shall present to the Engineer for approval the claim for a change in the Contract Price and change in Completion Time with appropriate documentation in a form acceptable to the Engineer. When the Engineer is satisfied as to the correctness of such claim and, when approved by the Owner, a change order shall be issued to the Contractor amending the Contract Price and Completion Time as appropriate. The value of Work performed in the change shall be included for payment with the regular certificates of payment.
- 13.4 In the case of Changes in the Work to be paid for under methods (b) of paragraph 13.2, the form of presentation of methods of measurement shall be agreed to by the Engineer and Contractor before proceeding with the change. The Contractor shall keep accurate records, as agreed upon, of quantities and present an account of the quantities for the Change in the Work.
- 13.5 In the case of changes in the Work to be paid for under method (c) of paragraph 13.2, the prices for any extra or additional Work shall be based on the sum of the following six items:
- (a) direct basic wages paid to labour excluding machine operators, administrative and supervisory staff, required to perform the Work in accordance with direction and when devoting exclusive attention to this Work;

- (b) twenty-five (25) percent of item 13.5 (a) to cover cost of small tools, payroll burden and employee benefit costs;
 - (c) The cost of material delivered to the Place of the Work;
 - (d) fifteen (15) percent of the sum of items 13.5 (a), (b), and (c), which shall cover overhead expense, profit, head office and site office overhead, including salaries of time-keeping, clerical, accounting, warehousing and other administrative personnel and all costs associated therewith;
 - (e) rental of construction equipment (including operators). The equipment rental rates shall be in accordance with equipment rental rates indicated in the latest edition of Road Builders Equipment Rates. In the absence of Road Builders Equipment Rates, Department of Transportation and Infrastructure Renewal rates shall apply.
 - (f) Standby time shall be the time when equipment is required on site but not operated to execute the required works. Approved standby time shall be paid for at 65% of the hourly rates.
 - (g) ten (10) percent mark-up on subcontractor work.
- 13.6 If the method of valuation, measurement, change in Contract Price and/or change in Completion Time cannot be promptly agreed upon, and the change is required to be proceeded with then the Engineer in the first instance will determine the method of valuation, measurement, change in Contract Price and/or Completion Time subject to final determination in the manner set out in GC 8 - DISPUTES. In this case the Engineer will, with the consent of the Owner, issue a written authorization for the change, setting out the method of valuation and if by lump sum valuation of the change in Contract Price and/or Completion Time.
- 13.7 In the case of a dispute in the valuation of a change authorized in the Work and pending final determination of such value, the Engineer will make an evaluation and certify the value of Work performed and include the amount with the regular certificates for payment. The Contractor shall keep accurate records of quantities and cost of such Work.
- 13.8 Should the actual quantity of an item in the Schedule of Quantities and Unit Prices, vary by more than 25% of the estimated quantity, either the Owner or the Contractor may request a revision to the Unit Price contained in the Schedule of Quantities and Unit Prices. Such a request for a revision in a Unit Price shall be given as soon as reasonably possible after the party concerned becomes aware of the circumstances.
- 13.9 If a revision to a Unit Price is negotiated pursuant to paragraph 13.8, then:
- (a) the revised unit price in the case of a decrease of more than 25% of the estimated quantity will apply to the actual Work performed for that item, and
 - (b) the revised unit price in the case of an increase of more than 25% of the estimated quantity will apply to the excess quantity of Work for that item only.
- 13.10 If either party request renegotiations of a Unit Price pursuant to paragraph 13.8, both parties shall act promptly in order to arrive at an equitable revision of the Unit Price prior to proceeding with the Work so affected. If agreement of such renegotiation cannot be reached, the Contractor shall proceed with the Work and the matter shall be subject to final determination in the manner set out in GC 8 - DISPUTES. Pending such settlement, payment for the Work performed shall be made on the regular certificates for payment on the basis of the Unit Prices set out in the Schedule of Quantities and Unit Prices.

13.11 In all matters referred to above both the Engineer and the Contractor shall act promptly.

GC 14 APPLICATIONS FOR PAYMENT

- 14.1 Applications for payment on account may be made monthly as the Work progresses.
- 14.2 Applications for payment shall be dated the last day of the agreed monthly payment period and the amount claimed shall be for the value of Work performed at that date and subject to a ten percent (10%) holdback.
- 14.3 Applications for release of holdback monies following Substantial Performance of the Work and the application for final payment shall be made at the time and in the manner set forth in GC 15 - CERTIFICATES AND PAYMENTS.

GC 15 CERTIFICATES AND PAYMENTS

- 15.1 The Engineer will, no later than seven (7) days after the receipt of an application for payment from the Contractor submitted in accordance with GC 14 - APPLICATION FOR PAYMENT, issue a progress payment certificate in the amount applied for or in such other amount deemed to be properly due. If the Engineer amends the application, the Engineer will promptly notify the Contractor in writing giving reasons for the amendment. Notwithstanding that the Contractor has not made application for payment, the Engineer may measure and value the Work performed during a payment period, prepare, and issue a progress payment certificate.
- 15.2 The Owner shall make payment to the Contractor on account no later than twenty (20) days after the issuance of a certificate for payment by the Engineer.
- 15.3 The Engineer will, no later than ten (10) days after the receipt of an application from the Contractor for a Certificate of Substantial Performance of the Work, make an inspection and assessment of the Work to verify the validity of the application. The Engineer, in consultation with the Contractor, will make a measurement of the Work completed to the date of the application and no later than seven (7) days after inspection, notify the Contractor of approval or the reasons for disapproval of the application. When the Engineer finds that Substantial Performance of the Work has been reached the Engineer will issue such a certificate. The date of Substantial Performance of the Work shall be as stated in this certificate. Immediately following the issuance of the Certificate of Substantial Performance of the Work, the Engineer, in consultation with the Contractor, will establish a reasonable date for the Work to be performed completely.
- 15.4 Immediately following the issuance of the certificate of Substantial Performance of the Work, the Engineer will issue a progress payment certificate for Work performed up to the date of Substantial Performance and a certificate for payment of holdback monies. Payment of one hundred percent (100%) of the accumulated holdback monies as authorized by this certificate shall become due and payable five (5) days after the following conditions have been satisfied:
- (a) sixty (60) days have elapsed from the date of Substantial Performance of the Work, and
 - (b) the Contractor has submitted to the Engineer, in one complete package, the following:

- (i) statutory declaration that all accounts for labour, subcontracts, products, construction machinery and equipment have been paid and the Owner is released from any and all further claims relating to the Contract, along with any statement of accounts from any supplier or Subcontractor that the Owner may request;
 - (ii) a clearance certificate from the Workers' Compensation Board;
 - (iii) security for the warranty period in accordance with GC 24 - SECURITY;
 - (iv) written release from each property owner whose lands were used by the Contractor in the execution of this Contract stating that such property has been restored; and
 - (v) written verification that all claims by third parties have been acknowledged and either resolved or under investigation by the Contractor's insurer.
- (c) the Contractor has agreed to, signed, and returned the Substantial Performance measurement certificate.

If however, the Contractor has failed to sign the measurement certificate within sixty (60) days of Substantial Performance of the Work and provided required documents as listed above, then the Owner shall release one hundred percent (100%) of the holdback within fourteen (14) days following the date on which the Contractor meets all these requirements.

- 15.5 No later than ten (10) days after the receipt of an application from the Contractor for final payment, the Engineer, in consultation with the Contractor, will complete the final measurement and inspection of the Work and, no later than seven (7) days after measurement and inspection, notify the Contractor of approval or the reasons for disapproval of the application.
- 15.6 When the Engineer finds the Work acceptable under the Contract Documents and the required Work is performed completely, the Engineer will promptly issue a final measure progress payment certificate. The certificate shall state that to the best of the Engineer's knowledge, information, and belief, and on the basis of the Engineer's observations and reviews, the Work has been completed in general accordance with the terms and conditions of the Contract Documents.
- The certificate shall state the balance due the Contractor and noted in said final measure certificate is due and payable.
- 15.7 No later than thirty (30) days after the date of Total Performance of the Work as certified by the Engineer, the Owner will release to the Contractor the balance of monies owing, subject to a ten percent (10%) holdback, provided that the following conditions have been satisfied:
- (a) the Contractor has submitted to the Engineer a statutory declaration stating that there are no Builders' Liens filed relating to the Work performed between Substantial Performance and the date when the required Work is performed completely;

- (b) the Contractor has submitted to the Engineer a clearance certificate from the Workers' Compensation Board;
- (c) the Contractor has agreed to, signed, and returned to the Engineer a copy of the final measure;
- (d) the Contractor has submitted to the Engineer any other information or documentation reasonably requested by the Owner.

If, however, the Contractor has failed to sign the measurement certificate within sixty (60) days of when the required Work is performed completely and to provide required documents as listed above, then the Owner shall release final payment fourteen (14) days following the date on which the Contractor meets all these requirements.

- 15.8 No payment made by the Owner under this Contract or partial or entire use or occupancy of the Work by the Owner shall constitute an acceptance of Work or products which are not in accordance with the requirements of the Contract Documents.
- 15.9 All certificates issued by the Engineer shall be to the best of the Engineer's knowledge, information and belief.

GC 16 TAXES AND DUTIES

- 16.1 The Contractor shall pay all government sales taxes, customs, duties, and excise taxes with respect to the Contract.
- 16.2 Where a recovery of taxes is applicable to the Contract, the amount recovered shall be the property of the Owner.
- 16.3 The Harmonized Sales Tax is not to be included in unit and lump sum prices.
- 16.4 The Contractor shall indicate on each application for payment as a separate amount the Harmonized Sales Tax applicable to the claim. The amount paid to the Contractor will be based on the amount of the application for payment certified by the Engineer.
- 16.5 Any increase or decrease in costs to the Contractor due to changes in such taxes and duties after the date of the tender shall increase or decrease the Contract Price accordingly.

GC 17 LAWS, NOTICES, PERMITS AND FEES

- 17.1 The laws of the Province of Nova Scotia shall govern the Work.
- 17.2 The Contractor shall obtain the permits, licenses and certificates and pay the fees required for the performance of the Work which are in force at the date of tender closing, but this shall not include the obtaining of permanent easements or rights of servitude. A street excavation permit is required for all projects, although there will be no charge for the HRM permit. For projects on Nova Scotia Department of Transportation and Infrastructure Renewal (NSDTIR) roads, the Contractor shall pay all fees and deposits required for NSDTIR permits.

- 17.3 The Contractor shall give the required notices and comply with the laws, bylaws, ordinances, rules, regulations, standards, codes, applicable HRM policies, and orders of HRM and other authorities having jurisdiction, which are or become in force during the performance of the Work, and which relate to the Work, to public health, to environment, to fisheries, and to construction safety.
- 17.4 The Contractor shall not be responsible for verifying that the Contract Documents are in compliance with the applicable laws, ordinances, rules, regulations, and codes relating to the Work. If the Contract Documents are at a variance therewith, or changes which require modification to the Contract Documents are made to the laws, ordinances, rules, regulations, or codes by the authorities having jurisdiction subsequent to the date of the tender closing, the Contractor shall notify the Engineer in writing requesting direction immediately such variance or change becomes known. The Engineer will make the changes required to the Contract Documents in accordance with GC 12 - CHANGES IN THE WORK AND EXTRA WORK, and the value of the changes shall be determined in accordance with GC 13 - VALUATION AND CERTIFICATION OF CHANGES IN THE WORK AND EXTRA WORK.
- 17.5 If the Contractor fails to notify the Engineer in writing and obtain direction as required in paragraph 17.4 and performs Work knowing it to be contrary to any laws, ordinances, rules, regulations, codes and orders of the authorities having jurisdiction, the Contractor shall be responsible for and shall correct the violations thereof and shall bear the costs, expenses and damages attributable to failure to comply with the provisions of such laws, ordinances, rules, regulations, codes and orders

GC 18 PATENT RIGHTS AND ROYALTIES

- 18.1 The Contractor shall pay all royalties and patent license fees required for the performance of the Contract. The Contractor shall hold the Owner harmless from and against all claims, demands, losses, costs, damages, actions suits or proceedings arising out of the Contractor's performance of the Contract which are attributable to an infringement or an alleged infringement of a patent of invention by the Contractor or anyone for whose acts the Contractor may be liable.
- 18.2 The Owner shall hold the Contractor harmless against all claims, demands, losses, costs, damages, actions, suits, or proceedings arising out of the Contractor's performance of the Contract which are attributable to an infringement or an alleged infringement of a patent of invention in executing anything for the purpose of the Contract, the model, plan or design which was supplied to the Contractor as part of the Contract Documents.

GC 19 WORKERS' COMPENSATION INSURANCE

- 19.1 Prior to commencing the Work, the Contractor shall provide a current clearance letter from the Workers' Compensation Board and **must** maintain this coverage during the whole term of the contract. HRM will only enter contracts with firms that provide WCB coverage.

19.2 WCB Clearance Letters provide clarity as to who is covered and who is not covered for individual firms (e.g. Directors not taking a T4 from the company are excluded from coverage, owners of sole proprietorships and partnerships are excluded from coverage, family members living in the household of a director or partner are excluded from coverage). It will be the responsibility of the Contractor to ensure coverage is in place for its employees and employees of any of its sub-contractors. Individuals not covered by WCB are not permitted on Halifax Regional Municipal property.

GC 20 INDEMNIFICATION

20.1 The Contractor shall indemnify and hold harmless the Owner, its agents, representatives and employees from and against all claims, demands, losses, costs, damages, actions, suits or proceedings arising out of or resulting from the performance of the Work (hereinafter called "Claims"), provided that any such claim is caused in whole or in part by the negligent act or omission of the Contractor, any Subcontractor, supplier, licensee, anyone directly or indirectly employed by any one of them or anyone for whose acts any of them is liable, regardless of whether or not it is caused in part by a party indemnified hereunder.

GC 21 INSURANCE

21.1 Without restricting the generality of Indemnification (20.1) the Contractor will provide and maintain insurance in accordance with the following minimum criteria:

(a) General Conditions All Insurance

- (i) The policies will be in the name of the Contractor (Named Insured). The Halifax Regional Municipality (HRM) will be added as an additional insured under this Contract.
- (ii) The policies will be primary to any other coverage with the same terms and conditions held by the named, additional, and unnamed insureds.
- (iii) All insurance shall be maintained continuously while this Contract is in force.
- (iv) If the Contractor fails to furnish the Owner with a certificate of insurance for each policy required to be obtained hereunder or if after furnishing such certificate of insurance the policy lapses, is cancelled, or is materially altered, then in every such case the Owner, without the obligation to do so, may obtain and maintain such insurance in the name of such Contractor. The cost thereof shall be payable by the Contractor to the Owner on demand, and the Owner may at its election deduct the cost thereof from any monies which are due or may become due to the Contractor. All certificates of insurance to be furnished under this Contract shall be provided

to the Owner before commencement of work, in a form and with an insurer(s) satisfactory to the Owner. Any review of such insurance by the Owner shall not be an acknowledgment that the terms of this agreement have been fulfilled.

- (v) The Contractor shall be responsible for any deductible amounts.
 - (vi) Each policy required to be placed by the Contractor shall state that it cannot be cancelled, lapsed, or materially altered without at least thirty (30) days written notice to the Owner.
- (b) Commercial General Liability Insurance
- This insurance will be subject to limits of not less than Five Million Dollars (\$5,000,000) inclusive per occurrence for bodily injury, death and damages to property including loss of use thereof, and including but not limited to coverage for:
- (i) where a guarantee period is required by the Owner under this Contract, the Contractor shall ensure that Completed Operations coverage, as applicable, shall be in force for the duration of the guarantee period or twelve (12) months, whichever is greater;
 - (ii) premises and operations liability, including all activities arising out of work performed;
 - (iii) owner's and contractor's contingent liability with respect to the operations of persons, firms or corporations having a contract for the execution of a part or parts of the Work included in the Contract;
 - (iv) products and completed operations liability;
 - (v) blanket contractual liability;
 - (vi) cross liability;
 - (vii) elevator and hoist liability;
 - (viii) contingent employer's liability;
 - (ix) personal injury liability;
 - (x) liability with respect to non-owned licensed vehicles;
 - (xi) the Contractor shall maintain coverage as noted in this paragraph to cover exposures or risks with respect to liability to owned and non-owned water craft;
 - (xii) if any part of the Work includes blasting, shoring, excavating, underground work, underpinning, demolition, pile driving or caisson work (none of which will be covered by the owner's insurance) it shall be the obligation of the Contractor to ensure that it, or the Subcontractor doing such part of the Work has liability coverage for risks arising out of such part of the Work.
 - (xiii) The Contractor shall obtain and maintain aircraft and watercraft liability insurance with respect to owned or non-owned aircraft and watercraft if used directly or indirectly in the performance of the Work, including use of additional premises, which shall be subject to limits of not less than \$5,000,000 inclusive per occurrence for bodily injury, death, and damage to property including loss of use thereof. Such insurance shall be in a form acceptable to the Owner. The policies shall be endorsed to provide the Owner with not less than 15 days' notice in writing in advance of cancellation, change, or amendment restricting coverage.

(c) Automobile Liability Insurance

The Contractor shall provide automobile liability insurance in respect to owned licensed vehicles subject to limits of not less than Five Million Dollars (\$5,000,000) inclusive.

(d) Contractors Environmental/Pollution Insurance

This insurance will be subject to limits of not less than One Million Dollars (\$1,000,000) inclusive per occurrence, including but not limited to coverage for:

- (i) 3rd party bodily injury/property damage (including natural resource damages);
- (ii) remediation expenses including restoration costs to restore property damaged in the course of remediation;
- (iii) emergency response costs;
- (iv) legal defence expenses;
- (v) non-owned disposal sites;
- (vi) transportation;
- (vii) fines and penalties arising from environmental contamination;
- (viii) asbestos abatement/removal/disposal; and
- (ix) mould and Legionella.

21.2 The Contractor shall provide proof of all required insurance to the Owner within five (5) working days of written notice of contract award unless the Owner provides permission otherwise.

GC 22 PROTECTION OF WORK AND PROPERTY

22.1 The Contractor shall protect the Work and the Owner's property and property adjacent to the place of the Work from damage, and shall be responsible for damage which may arise as the result of operations under the Contract.

22.2 Should the Contractor in the performance of this Contract damage the Work, the Owner's property or property adjacent to the Place of the Work, the Contractor shall be responsible for the making good of such damage at the Contractor's expense.

GC 23 DAMAGES AND MUTUAL RESPONSIBILITY

23.1 If either party to this Contract should suffer damage in any manner because of any wrongful act or neglect of the other party or of anyone for whom the party is responsible by law, then the party suffering damage shall be reimbursed by the other party for such damage. The party reimbursing the other party shall be subrogated to the rights of the other party in respect of such wrongful act or neglect if it be that of a third party.

23.2 Claims under this General Condition shall be made in writing to the party liable within reasonable time after the first observance of such damage and may be adjusted by agreement or in the manner set out in GC 8 - DISPUTES.

- 23.3 If the Contractor has caused damage to an Other Contractor on the Work, the Contractor agrees upon due notice to settle with such Other Contractor by agreement or arbitration, if the Other Contractor will so settle. If such Other Contractor sues the Owner on account of damage alleged to have been so sustained, the Owner shall notify the Contractor and may require the Contractor to defend the action at the Contractor's expense. If a final order or judgement against the Owner arises therefrom, the Contractor shall pay or satisfy it and pay the costs incurred by the Owner.
- 23.4 If the Contractor becomes liable to pay or satisfy a final order, judgement, or award against the Owner then the Contractor, upon undertaking to indemnify the Owner against any and all liability for costs, shall have the right to appeal in the name of the Owner such final order or judgement to any and all courts of competent jurisdiction.
- 23.5 Notwithstanding any other provision contained in these General Conditions or contained elsewhere in the Contract Documents, under no circumstances shall the Owner be liable for any incidental, indirect, special, or consequential damages of any kind, including those arising from or measured by lost revenues or profits, even if the Owner has been advised of such damages.

GC 24 SECURITY

- 24.1 The Contractor shall, prior to the commencement of the Work or within the specified time, provide to the Owner any Contract security specified in Section 00 73 63 CONTRACT SECURITY REQUIREMENTS.

GC 25 WARRANTY

- 25.1 The Contractor shall correct promptly, at its own expense, defects or deficiencies in the Work which appear prior to and during the period of two years from the date of Substantial Performance of the Work, as set out in the Certificate of Substantial Performance of the Work, or such longer period as may be specified for certain products or Work.
- 25.2 During the period provided in GC 3- ENGINEER paragraph 3.2, the Engineer shall promptly give the Contractor written notice of observed defects and deficiencies. For traffic signal systems, the Engineer shall include a priority rating as per the requirements of 25.2(a)(i).

The Contractor shall be required to perform to the satisfaction of the Engineer all necessary warranty repairs to such traffic signal system components (traffic control signals and other signals, electrical and electronic equipment, and traffic signs) which become defective or damaged due to Work completed by the Contractor.

For traffic signal systems, the Contractor shall be required to provide such warranty emergency service 24 hours per day, each day of the year. Warranty emergency service shall begin immediately upon notification of a defect in any device. The Contractor shall be held responsible for any damages to equipment or to the public which may result from or be attributed to any defect in, failure or damage to, any such traffic control device covered by this Contract.

Electricians with a minimum International Municipal Signal Association (IMSA) Traffic Signals Level 1 Certification shall be on call for emergency call out. The service crew must consist of two people, the second of which shall be an apprentice or helper.

- (a) Scheduling and Coordination of Traffic Signal System Defects and Deficiencies
 (i) Schedule, coordinate, and perform the work to the following priorities:

| Priority | Response Time | Temporary Repairs Completed | Permanent Repairs Completed |
|-----------------|--|------------------------------------|------------------------------------|
| High* | Within 1 hour | Within 1 hour of site arrival | Within 24 hours |
| Normal** | End of next working day | Within 1 hour of site arrival | Within 48 hours |
| Low | To be scheduled with the Traffic and Right of Way by the end of next working day | N/A | As scheduled |

* (generally consists of twisted heads, red signal failures and malfunctioning signal equipment)

** (generally consists of RA5 failures, signal failures other than red)

- (ii) The Owner is the sole judge and will establish the priority level for all warranty work.
- (iii) The Contractor shall notify the Engineer when it arrives at the Place of Work for any warranty work.
- (iv) Failure to meet the priority response time shall result in the Owner having the work completed by another contractor or by the Owner's own forces. All costs for the repairs will be the responsibility of the Contractor.
- (v) Contractor is to provide a single telephone number and fax number, typically a pager/cell phone, where the on-call person can be reached 24 hours per day.

25.3 The Contractor agrees to correct or pay for damage resulting from corrections made under the requirements of paragraph 25.2.

GC 26 CONTRACTOR'S RESPONSIBILITY AND CONTROL OF WORK

26.1 The Contractor shall have complete control of the Work and shall effectively direct and supervise the Work so as to ensure conformance with the Contract Documents. The Contractor shall be solely responsible for construction means, methods, techniques, sequences, and procedures and for coordinating the various parts of the Work under the Contract.

26.2 The Contractor shall be responsible for construction safety at the Place of the Work and for compliance with the rules, regulations and practices as set out in the Occupational Health and Safety Act of the Province of Nova Scotia. Before being permitted access to the site to commence construction, the Contractor shall provide the Owner with a written

site safety plan. The site safety plan provided shall be a written course of action that, through a pre-job evaluation, identifies and sets out specific actions to be taken to eliminate or control, hazards associated with the Work to be performed and to also deal with concerns or hazards that may develop during the course of the Project. This plan shall include but not be limited to identification of safety hazards anticipated during the Project, solutions to those hazards, safety procedures, identification of designated safety officers and provisions for safe access to the Place of the Work for the Owner's staff and consultants. Receipt and review of the safety plan shall be mandatory prior to commencement of Work.

26.3 The Contractor shall:

- (a) comply with all health and safety and environmental legislation in the performance of this Contract and to practice the principles of proactive Due Diligence.
- (b) maintain a safe and healthy work environment during the performance of this Contract.

26.4 The Contractor shall:

- (a) comply with all health and safety and environmental legislation and any HRM policy or procedure applied to or applicable to this Contract is a condition of the Contract.
- (b) permit the Owner to audit or inspect the Contractor's health and safety and environmental records during the term of the Contract and upon its conclusion and to co-operate fully with any such audit or inspection.

26.5 The Contractor shall agree:

- (a) that the Owner may address Contractor safety deficiencies in the following progressive steps:
 - (i) The problem will be identified to the Contractor, (site supervisor).
 - (ii) The Contractor's head office will be contacted about the problem, orally and followed up in writing.
 - (iii) The Contract may, at the discretion of the Owner, be suspended or terminated and/or payment withheld by the Owner.
 - (iv) If required to do so by legislation, the Owner will immediately report the problem to the appropriate regulatory authority.
- (b) that depending upon the nature and/or seriousness of the deficiency the Owner reserves the right to bypass any or all of the steps described in subsection GC 26.5(a)

26.6 The Contractor shall acknowledge receipt of a copy of HRM Contractor Safety Management Policy as found on the Owner's web site at www.halifax.ca/procurement and that the Contractor understands and shall undertake to adhere to the terms of this Policy and to co-operate with the Owner in its efforts to ensure compliance thereunder.

26.7 The Contractor shall have the sole responsibility for the design, erection, operation, maintenance and removal of temporary structural and other temporary facilities and the design and execution of construction methods required in their use. The Contractor shall engage and pay for registered professional engineering personnel, skilled in the

appropriate disciplines to perform these functions where required by law or by the Contract Documents and in all cases where such temporary facilities and their method of construction are of such a nature that professional engineering skill is required to produce safe and satisfactory results.

- 26.8 Notwithstanding the provisions of paragraphs 26.1 and 26.3, or provisions to the contrary elsewhere in the Contract Documents, where such Contract Documents include designs for temporary structural and other temporary facilities or specify a method of construction in whole or in part, such facilities and methods shall be considered to be part of the design of the Work and the Contractor shall not be held responsible for that part of the design or the specified method of construction. The Contractor shall, however, be responsible for the execution of such design or specified method of construction in the same manner that the Contractor is responsible for the execution of the Work.
- 26.9 The Contractor shall review the Contract Documents and shall promptly report to the Engineer any error, inconsistency or omission of the Contract Documents. Such review shall be to the best knowledge, information and belief and in making such review the Contractor does not assume any responsibility to the Owner or the Engineer for the accuracy of the review. The Contractor shall not be liable for damage or costs resulting from such errors, inconsistencies or omissions in the Contract Documents which were not discovered. If the Contractor does discover any error, inconsistency or omission in the Contract Documents, Work affected shall not proceed until corrected or missing information is received from the Engineer.
- 26.10 The Contractor shall prepare and update as required (at least monthly) a construction schedule indicating the timing of the major activities of the Work. The schedule shall be designed to ensure conformance with the required Completion Time. The schedule shall be submitted to the Engineer within five (5) working days of the date of Contract award. The Contractor shall monitor the progress of the Work relative to the schedule and advise the Engineer of any revisions required as the result of delays as provided in GC 4 - DELAYS, indicating the results expected from the resultant change in schedule.

GC 27 SUPERINTENDENCE

- 27.1 The Contractor shall employ a competent supervisor and necessary assistants who shall be in attendance at the Place of the Work while Work is being performed.
- 27.2 The supervisor shall be satisfactory to the Engineer and shall not be changed except for good reason and only then after consultation with the Engineer.
- 27.3 The supervisor shall represent the Contractor at the Place of the Work and be fully empowered to act for and on behalf of and to bind the Contractor in all matters at the site that pertain to the Contract. Instructions given to the supervisor by the Engineer shall be held to have been given to the Contractor.
- 27.4 The supervisor shall, if required by the Engineer, be solely employed upon work directly connected with the Contract.

GC 28 LABOUR AND PRODUCTS

- 28.1 Unless otherwise stipulated elsewhere in the Contract Documents, the Contractor shall provide and pay for labour, products, tools, construction equipment and machinery, water, heat, lights, power, transportation and other facilities and services necessary for the performance of the Work in accordance with the Contract.
- 28.2 Products provided shall be new unless otherwise specified in the Contract Documents. Products which are not specified shall be of a quality best suited to the purpose required and their use subject to the approval of the Engineer.
- 28.3 The Contractor shall maintain good order and discipline among employees engaged on the Work and shall not employ on the Work anyone not skilled in the assigned task.

GC 29 SUBSURFACE CONDITIONS

- 29.1 The Contractor shall promptly notify the Engineer in writing if subsurface conditions at the Place of the Work differ significantly from those indicated in the Contract Documents, or a reasonable assumption of probable conditions based thereon.
- 29.2 After prompt investigation, should the Engineer determine that conditions do differ significantly, the Engineer will issue appropriate instructions for changes in the Work in accordance with GC 12 - CHANGES IN THE WORK AND EXTRA WORK, and the value of the changes shall be determined in accordance with GC 13 - VALUATION AND CERTIFICATION OF CHANGES IN THE WORK AND EXTRA WORK.
- 29.3 The location of existing utilities is approximate only and the best known to the Engineer at the time of Tender call. It shall be the responsibility of the Contractor to check the exact location of all utilities from various owners before starting of the Work. The Contractor is deemed to have included all the costs which may be necessary to protect utilities as required by various owners. No additional cost shall be considered by the Owner which the Contractor may have to bear to protect existing utilities. Notwithstanding the provisions of 29.1 and 29.2 the Owner will not consider payment of extra cost which the Contractor may incur to protect existing utilities.

GC 30 USE OF THE WORK

- 30.1 The Contractor shall confine apparatus, storage of products, and operations of employees to limits indicated by laws, ordinances, permits or the Contract Documents and shall not unreasonably encumber the premises with products.
- 30.2 The Contractor shall not load or permit to be loaded any part of the Work with a mass or force that will endanger the safety of the Work.

GC 31 INSPECTION OF THE WORK

- 31.1 The Owner and the Engineer or their authorized agents or representatives shall at all times have access to the Work. If parts of the Work are in preparation at locations other than the Place of the Work, the Owner and the Engineer or their authorized agents or representatives shall be given access to such Work whenever it is in progress.

- 31.2 If Work is designated for special tests, inspections or approvals in the Contract Documents, or by the Engineer's instructions, or the laws or ordinances of the Place of the Work, the Contractor shall give the Engineer timely notice requesting inspection. Inspection by the Engineer shall be made promptly. The Contractor shall arrange for inspections by other authorities and shall give the Engineer timely notice of the date and time. Minimum twelve (12) hours' notice, in writing, shall be provided to the Owner's designated materials, testing and inspection contractor. The Owner shall also be copied on any such notices.
- 31.3 If the Contractor covers or permit to be covered any Work that has been designated for special tests, inspections or approvals before such special tests, inspections or approvals are made, given or completed, the Contractor shall, if so directed, uncover such Work, have the inspections or tests satisfactorily completed and make good such Work at own expense.
- 31.4 The Engineer may order any part or parts of the Work to be specially examined should the Engineer believe that such Work is not in accordance with the requirements of the Contract Documents. If, upon examination, such Work be found not in accordance with the requirements of the Contract documents, the Contractor shall correct such Work and pay the cost of examination and correction. If such Work be found in accordance with the requirements of the Contract documents, the Owner shall pay the cost of examination and replacement.
- 31.5 The Contractor shall furnish promptly the Engineer two (2) copies of certificates and inspection reports relating to the Work.

GC 32 REJECTED WORK

- 32.1 Defective work, whether the result of poor workmanship, use of defective products, or damage through carelessness or other act or omission of the Contractor and whether incorporated in the Work or not, which has been rejected by the Engineer as failing to conform to the Contract Documents shall be removed promptly from the Place of the Work by the Contractor and replaced or re-executed promptly in accordance with the Contract Documents at the Contractor's expense.
- 32.2 Other Contractors' Work destroyed or damaged by such removals or replacements shall be made good promptly at the Contractor's expense.
- 32.3 If in the opinion of the Engineer it is not expedient to correct defective work or work not performed in accordance with the Contract Documents, the Owner may deduct from the monies otherwise due to the Contractor the difference in value between the work as performed and that called for by the Contract Documents, the amount of which will be determined in the first instance by the Engineer.

GC 33 PRODUCTS SUPPLIED BY OWNER

- 33.1 If the Contract provides that products are to be supplied by the Owner, the point of delivery shall be as designated by the Engineer.

- 33.2 The Contractor shall take full responsibility for the care and protection of all products supplied by the Owner from the time of arrival at the designated delivery point until the Work is fully performed.
- 33.3 As soon as the Contractor has been notified that products supplied by the Owner have arrived at the designated delivery point, the Contractor shall inspect, accept, unload and store the products.
- 33.4 The Contractor shall note on the freight or delivery slip any defects or shortages noted at the time of delivery and the Owner shall be notified of shortage or defect promptly.
- 33.5 The Contractor shall, at Substantial Performance of the Work, collect all unused products which were supplied by the Owner and deliver to a place designated by the Engineer. If such products are not collected and returned in good order, their cost shall be deducted from payments otherwise due to the Contractor.

GC 34 LIQUIDATED DAMAGES

- 34.1 Time shall be construed as being of the essence of the Contract.
- 34.2 The date of expiring of the time allowed in accordance with the Contract for Completion Time shall be termed the "Date for Substantial Performance of the Work".
- 34.3 Should the Contractor fail to complete the Work by the Date of Substantial Performance of the Work, the period of time from the Date for Substantial Performance of the Work to the date when the required Work is performed substantially, as determined by the Engineer, shall be termed the "Period of Delay".
- 34.4 The Contractor recognizes and agrees that the Owner will suffer financial loss if there is a Period of Delay. The Contractor also recognizes the difficulties involved in proving and quantifying the actual loss suffered by the Owner as a result of unexcused delays. Accordingly, instead of requiring any such proof, the Contractor agrees that as liquidated damages for delay (but not as penalty) the Contractor shall pay to the Owner \$1,000.00 per day for each and every working day from the agreed upon Date for Substantial Performance of the Work until Substantial Performance of the Work is actually achieved.

It is further expressly acknowledged and agreed by the Contractor that:

- (a) this amount is a reasonable estimate of the actual damage that will be incurred by the Owner due to any failure to complete the Work by the Date for Substantial Performance of the Work; and
- (b) the Owner may deduct the amount due under this paragraph from any amounts that may be due or payable to the Contractor, whether under this Contract or any other agreement.

GC 35 HOURS AND DAYS OF WORK

- 35.1 Normal working days shall be all days other than Saturdays, Sundays, and Holidays observed at the Place of the Work. Working hours shall be governed by applicable noise bylaws and regulations. Normal working hours shall consist of ten (10) hours between 7:00 a.m. and 6:00 p.m., including a one half-hour lunch break.

- 35.2 If the Contractor wishes to work outside normal working hours and days of work, permission shall be obtained from the Engineer.
- 35.3 The Engineer may require the Contractor to perform Work outside the normal hours and days of work at no additional cost to the Contract.
- 35.4 Notwithstanding the above, the Contractor is advised that no work under this Contract shall be performed on Remembrance Day, November 11.
- 35.5 Notwithstanding the above, the Contractor is advised that work under this Contract shall be limited on the first day of school on those streets abutting school properties and on election days on those streets abutting polling stations.

GC 36 LAND

- 36.1 The Owner shall provide the lands upon which the Work is to be constructed, rights-of-way for access, easements, and such other lands which are designated for the use of the Contractor.
- 36.2 If the Contractor deems it advisable to acquire the right or rights to use, enjoy or occupy additional land or lands in order to facilitate the execution of the Works, the Contractor shall obtain such right or rights at own expense and without liability to the Owner.

GC 37 ORDER TO START WORK

- 37.1 No Work shall be started, nor materials or equipment moved to the Place of the Work, until after receipt by the Contractor of the Order to Start Work. The Work shall commence within the time indicated on the Order to Start Work unless otherwise agreed in writing. Failure of the Contractor to start the Work within the time indicated shall give the Owner the right to cancel the Contract.

GC 38 SETTING OUT THE WORK

- 38.1 Unless otherwise specified, the Contractor is responsible to develop and make all detail surveys required for the laying out of the various work components with the assistance of available information as supplied by the Owner.
- 38.2 The Contractor shall carefully preserve benchmark reference points and stakes and in case of willful or careless destruction, the Contractor shall be responsible for any mistakes that may be caused by their unnecessary loss or disturbance.

GC 39 LOCAL OFFICE AND TELEPHONE NUMBERS

- 39.1 For designated projects the Contractor shall be required to maintain a site office which shall be staffed during normal working hours.
- 39.2 The Contractor shall provide the Engineer with the names and telephone numbers of two (2) representatives in the Halifax Metro Area of which at least one (1) will be available after hours, including weekends and holidays. This person shall be responsible to take remedial action identified by the Owner.

GC 40 TIME FOR COMPLETION

- 40.1 The required Work shall be performed completely within the time stated in the Bid Form.
- 40.2 If the Contractor requests any extensions of time for completion of the Works to do extra Work, strikes, lockouts, fires, insurrection, Acts of God, or delay in delivery of equipment, or by any act of the Owner, or from such other cause for which the Contractor cannot reasonably be held responsible, the Contractor shall give notice in writing to the Engineer within seven (7) days after any such delay has first arisen, stating the reason and requesting a stated extension of time, and in such event the Engineer shall determine what extension of time, if any, shall be allowed the Contractor.

GC 41 VENDOR PERFORMANCE EVALUATION

41. The Contractor will be evaluated in its performance during the Contract. During construction, if performance concerns arise, a meeting or meetings may take place to discuss and resolve issues.

A Vendor Performance Evaluation form will be completed by the Engineer at the completion of the Contract. A copy of the complete form will be provided to the Contractor by the Owner.

Should the Contractor be at variance with the evaluation of its performance, the Contractor, within fourteen (14) days of receipt of the Vendor Performance Evaluation form, shall give notice in writing to the Director of Procurement and set out the terms of the variance.

If, in the opinion of the Owner, performance ratings indicate a meeting between the Contractor and the Owner are warranted, the Owner will invite the Contractor to meet and discuss the performance concerns. These discussions shall focus on specific issues and the outcomes will be summarized in a confirming letter. The Contractor may be invited to respond by letter, as to the measures it proposes to make, to correct or mitigate the concerns. Information in the evaluation may be used in future tender evaluations as an award recommendation.

****** END OF SECTION 00 72 45 ******

Halifax Regional Municipality Standard Details referenced below are as found in the Municipal Design Guidelines at: <https://www.halifax.ca/transportation/streets-sidewalks/municipal-design-guidelines-red-book> and/or in Section 39 00 00 found at: <https://www.halifax.ca/business/doing-business-halifax/procurement/terms-conditions>

INDEX TO CLAUSES

GENERAL

EARTHWORK

1. Clearing
2. Grubbing
3. Mass Excavation and Embankment - Common
4. Mass Excavation and Embankment - Rock
5. Mass Excavation - Unsuitable Material
6. Replacement of Unsuitable Material with Type 2 Gravel or Surge Rock
7. Borrow
8. Breaking Mass Rock Without Removal
- 9.1 Scarify Existing Road Surface
- 9.2 Fine Grading of Road Surface

WATER SYSTEM

10. Pipe
11. Fire Hydrant
12. Valve Chamber
13. Direct Buried Valve
14. Water Service
15. Connection to Existing Main
16. Water Main Protection
17. Temporary Water Service
18. Reserved
19. Reserved

SANITARY SEWER

20. Gravity Pipe
21. Pressure Pipe
22. Manholes
23. Services
24. Connections to Existing Main
25. Closed Circuit Television Inspection
26. Removal of Existing Structures
27. Reserved
28. Reserved
29. Reserved

STORM SEWER

- 30. Pipe
- 31. Manholes
- 32. Catchbasins
- 33. Catchbasin Leads
- 34. Services
- 35. Connections to Existing Main
- 36. Culverts
- 37. Closed Circuit Television Inspection
- 38. Removal of Existing Structure
- 39.1 Culvert Headwall
- 39.2 Culvert Apron
- 39.3 Inlet/Outlet Grate/Structure
- 39.4 Headwall Railing
- 39.5 Ditch Cleaning
- 39.6 Ditching

STREET CONSTRUCTION

- 40. Gravels
- 41. Placement Materials
- 42. Asphaltic Concrete
- 43. Curb
- 44. Sidewalk
- 44.5 Asphalt Walkway
- 45. Retaining Wall
- 46. Traffic Sign Base
- 47.1 Adjust Existing Structures to Grade
- 47.2 Replace Frames and Grates or Covers (Including Final Grade Adjustment)
- 47.3 Adjust Existing Adjustable Frames and Covers
- 47.4 Adjust Existing Adjustable Frames and Covers (Micro surfacing)
- 48. Type 2 Gravel or Surge Rock Below Subgrade
- 49. Driveway Reinstatement

LANDSCAPING

- 50. Topsoil and Sod
- 51. Topsoil and Seed
- 52. Trees, Shrubs and Groundcover
- 53. Hydroseed
- 54. Tree Removal
- 54.5 Tree Trimming
- 54.6 Migratory Bird Assessment
- 55. Chip Trees in Place
- 56. Bark Mulch
- 57. Handrails and Fences
- 58. Tree Stump Removal
- 59. Soil Cells

ADDITIONAL ITEMS

- 60. Trench Excavation - Rock
- 61. Trench Excavation - Unsuitable Material
- 62. Replacement of Unsuitable Material with Type 2 Gravel or Surge Rock
- 63. Topsoil Excavation
- 64. Breaking Trench Rock Without Removal
- 65.1 Painted Pavement Markings
- 65.2 Thermoplastic Pavement Markings
- 66. Preblast Survey
- 67. Preblast Trenches
- 68. Trench Plugs
- 69. Traffic Calming

ENVIRONMENTAL PROTECTION

- 70. Erosion and Sediment Control Plan
- 71. Sediment Controls
- 72. Ground Cover
- 73. Flow Diversions
- 74. Reserved
- 75. Reserved
- 76. Reserved
- 77. Reserved
- 78. Reserved
- 79. Reserved

ELECTRICAL

- 80. Direct Buried Conduit
- 81. Traffic Concrete Bases
- 82. Overhead Wiring for Detector Loops
- 83. Detectors
- 84. RA-5 Crosswalk Lights
- 85. Traffic Signal Installation
- 86. Ornamental Street Light
- 87. Area Lighting
- 88. Junction Box Removal
- 89. Reserved

MISCELLANEOUS

- 90. Project Information Sign
- 91. Reserved
- 92. Guiderails
- 93. HDPE Gas Distribution Pipe
- 94. Tactile Walking Surface Indicator Plates
- 95. Pavement Marking Drawing
- 96. Daylighting Underground Utilities
- 97. Delineators
- 98. Surveyed Planing Layout
- 99. Hydro Excavation Services
- 100. Traffic Control
- 102. Streetscaping

GENERAL

1. Unit prices are full compensation for the work necessary to complete each item in the Contract and in combination for all work necessary to complete the Work as a whole.
2. For sanitary sewers and storm sewer systems include all of the following as required where individual quantities are not provided in the Bid Form: clearing and grubbing, common excavation, shoring, dewatering, bedding, backfilling, compaction, disposal of surplus common, mechanical joint restraints or thrust blocks as directed, testing, flushing, marker stakes, traffic control, all incidentals and reinstatement as specified.
3. All measurement shall be along a horizontal plane unless otherwise indicated. Scale tickets for gravels and asphaltic concrete shall be provided within 48 hours, when requested by the Engineer, regardless of the unit of measurement.
4. The numbers of the items described below correspond to the numbers of the items in Section 00 41 43, Bid Form – Schedule of Quantities and Unit Prices.
5. For water systems include all of the following as required where individual quantities are not provided in the Bid Form: clearing and grubbing, common excavation of trench material, shoring, dewatering, bedding, pipe protection, polyethylene encasement, backfilling, compaction, joint restraints and thrust blocks, testing, flushing and disinfection, marker stakes, traffic control, all incidentals and reinstatement as specified.
6. For earthwork, street construction and landscaping include all of the following as required where individual quantities are not provided in the Bid Form: clearing and grubbing, removals, borrow, common excavation, backfilling, compaction, disposal of surplus material, pavement markings, tree removal, traffic control, all incidentals and reinstatement as specified.
7. The quantities listed in the Schedule of Quantities and Unit Prices are approximate only and are for the purpose of tendering. Payment to the Contractor will be based on actual quantities of work completed in accordance with the drawings and specifications.
8. The requirement for items indicated as Provisional will not be determined until the time of construction. Provisional items shall mean that the unit prices as tendered shall be included in the Bid Price and that the Owner reserves the right to delete or modify the quantities of these items.

EARTHWORK1. Clearing

Unit of Measurement: hectare (ha) or square metre (m²) or lump sum (l.s.)

This item includes: cutting and disposal of all trees and brush from areas indicated.

2. Grubbing

Unit of Measurement: hectare (ha) or square metre (m²) or lump sum (l.s.)

This item includes: removal and disposal of all stumps, roots, downed timber, embedded logs, rootmat, humus, and topsoil from areas indicated.

3. Mass Excavation and Embankment – Common

Unit of Measurement: cubic metre (m³) of cut

Method of Measurement: average end area method between cross sections taken after grubbing or topsoil removal and to the finished surface lines and elevations indicated.

This item includes: excavation, placement and compaction to the finished surface lines and elevations indicated, and disposal of surplus or unsuitable material.

4. Mass Excavation and Embankment – Rock

Unit of Measurement: cubic metre (m³) of cut

Method of Measurement: average end area method between cross sections taken after rock is exposed to lines and elevations indicated. Boulders one cubic metre or larger will be classified as rock. Boulders removed from the excavation shall be measured along the three maximum perpendicular axes.

This item includes: excavation, placement and compaction to lines and elevations indicated, and disposal of surplus or unsuitable material.

5. Mass Excavation – Unsuitable Material

Unit of Measurement: cubic metre (m³).

Method of Measurement: average end area method of volume of unsuitable material between cross sections taken before and after excavation.

This item includes: all excavation of unsuitable material and disposal. Written authorization of Engineer required.

6. Replacement of Unsuitable Material with Type 2 Gravel or Surge Rock

Unit of Measurement: cubic metre (m³) or tonne (t).

Method of Measurement: average end area method for volume of unsuitable material or ticket of surge material.

This item includes: placing Type 2 gravel or surge rock in locations where unsuitable material has been excavated as indicated on the plan or as directed by the Engineer. It also includes compaction of the gravel and placement of filter fabric. Written authorization of Engineer required.

7. Borrow

Unit of Measurement: lump sum (l.s.) or cubic metre (m³) or tonne (t).

Method of Measurement: lump sum or average end area method between cross sections taken before placement of borrow to lines and elevations indicated.

This item includes: supply of new material, placement, and compaction.

8. Breaking Mass Rock Without Removal

Unit of Measurement: cubic metre (m³).

Method of Measurement: average end area method between cross sections taken between surface of rock to lines and elevations indicated, and excluding the volume of mass excavation.

This item includes: breaking of rock to the size indicated, and excavation and backfilling test holes as directed by the Engineer.

9.1 Scarify Existing Road Surface

Unit of Measurement: square metre (m²)

Method of Measurement: slope measure

This item includes: scarifying the existing gravel sub-base to depth indicated to remove any material larger than 50 mm and mix gravels to an even consistency. This item also includes all necessary labour and equipment required for the fine grading and compaction of existing granular material.

9.2 Fine Grading of Road Surface

Unit of Measurement: square metre (m²)

Method of Measurement: slope measure

This item includes: necessary labour and equipment required for the fine grading of Type 1 granular materials, to the lines and elevations as indicated, prior to asphaltic concrete placement.

WATER SYSTEM10. Pipe

Unit of Measurement: metre (m)

Method of Measurement: along centerline of pipe through fittings, valves and valve chambers.

This item includes: supply and install pipe complete with all fittings and thrust restraints, testing, chlorination and de-chlorination, bedding and pipe protection gravels, polyethylene encasement, common excavation, removal and disposal of existing pipe within or partially within theoretical trench, backfilling, environmental protection and reinstatement up to and including Type 2 gravels as specified.

11. Fire Hydrant.1 Installation of Fire Hydrant

Unit of Measurement: Each

This item includes: supply and install hydrant complete with lead, polyethylene encasement, anchor tee, valve, valve box, anodes, thrust blocks, bedding and pipe protection gravels, common excavation, backfilling including Type 2 gravel as specified, finish grade adjustments, removal of

existing hydrant when installed within the existing trench and hydrant painting. Existing hydrants shall be returned to Halifax Water in full working order.

.2 Relocation of Fire Hydrant

Unit of Measurement: Each

This item includes: relocation of existing hydrant plus the supply and installation of lead, polyethylene encasement, anchor tee, valve, valve box, anodes, thrust blocks, bedding and pipe protection gravels, common excavation, backfilling including Type 2 gravel as specified and finish grade adjustments of the valve and hydrant.

.3 Relocation of Fire Hydrant (including vertical adjustment)

Unit of Measurement: Each

This item includes: relocation of existing hydrant (including vertical adjustment) plus the supply and installation of lead, polyethylene encasement, anchor tee, valve, valve box, anodes, thrust blocks, bedding and pipe protection gravels, common excavation, backfilling including Type 2 gravel as specified and finish grade adjustments of the valve and hydrant.

.4 Removal of Fire Hydrant

Unit of Measurement: Each

This item includes: common excavation, backfilling including Type 2 gravel as specified and removal of hydrant complete with all reinstatement. Hydrants shall be returned to Halifax Water in full working order.

.5 Reconnection of Fire Hydrant

Unit of Measurement: Each

This item includes: reconnection of a fire hydrant including the supply and installation of lead, polyethylene encasement, anchor tee, valve, valve box, anodes, thrust blocks, bedding and pipe protection gravels, common excavation, backfilling including Type 2 gravel as specified and finish grade adjustments of the valve and hydrant.

.6 Raise Fire Hydrant

Unit of Measurement: Each

This item includes: vertical adjustment plus the supply and installation of lead, polyethylene encasement, anchor tee, valve, valve box, anodes, thrust blocks, bedding and pipe protection gravels, common excavation, backfilling including type 2 gravel as specified and finish grade adjustments of the valve and hydrant.

12. Valve Chamber

Unit of Measurement: Each

This item includes: supply and install chamber and components as per Halifax Water specifications including connection to new/existing water mains complete with all fittings, bedding and gravels, common excavation, backfilling including Type 2 gravel as specified, vents and drains.

13. Direct Buried Valve

Unit of Measurement: Each

This item includes: supply and install direct buried valve complete with valve box, appurtenances, polyethylene encasement, anodes, common excavation, backfilling including Type 2 gravel as specified and finish grade adjustment.

14. Water Service

.1 Reconnect Existing Water Service

Unit of Measurement: Each

This item includes: saddle as required, tapping, corporation stop, service pipe (maximum 3 metres in length), couplings (if required) and anode for services 50 mm and less or tee, gate valve, valve box, anodes, pipe (if required) and couplings for service greater than 50 mm.

.2 Replace Existing Water Service

Unit of Measurement: Each

This item includes: excavation, removal and disposal of existing pipes within or partially within theoretical trench, bedding and backfilling, supply and placement of pipe

complete with saddle as required, tapping, corporation stop, curb stop, tee, gate valve, service box (c/w finish grade adjustment), anode and reinstatement up to and including Type 2 gravels as specified.

15. Connection to Existing Main

Unit of Measurement: lump sum (l.s.)

This item includes: locating existing main and supply and installation of pipe, nipples, valves, reducers, fittings, common excavation, backfilling including Type 2 gravel as specified and reinstatement. This item also includes producing and distributing temporary shutdown notices to affected customers and providing traffic control to Halifax Water Operations to facilitate shutdown.

16. Water Main Protection

.1 Rigid Insulation

Unit of Measurement: square metre (m²)

Method of Measurement: along center line of pipe

This item includes: supply and install 50 mm HI40 rigid insulation as directed by the Engineer.

.2 Pipe Sleeve (encasement pipe)

Unit of Measurement: Each

This item includes: supply and install DR18 pipe sleeves in minimum 6 metre lengths complete with all necessary appurtenances including, but not limited to, modular mechanical seals (such as Link-Seal or approved equivalent) at each end. Sites requiring pipe sleeve may be directed by the Engineer.

17. Temporary Water Service

Unit of Measurement: lump sum (l.s.)

This item includes: but is not limited to, the supply of all labour, material and equipment required for installing, maintaining and removing a minimum 50 mm diameter temporary main line and 19 mm service laterals complete with valves, pipe, backflow prevention device (sized to match temporary main line diameter), meter (supplied by Halifax Water), and vacuum breakers at the connection

to homes, etc. See Halifax Water Supplemental Specification Section 33 11 00 Water Mains for further information.

This item also includes installation of approved vehicle and pedestrian crossing protective measures along with producing and distributing notice to customers that will be placed on temporary water.

18. Reserved

19. Reserved

SANITARY SEWER 20. Gravity Pipe

Unit of Measurement: metre (m)

Method of Measurement: along centreline of pipe through manholes and/or termination points indicated.

.1 Gravity Pipe

This item includes: excavation, removal and disposal of existing pipe within or partially within theoretical trench, bedding and backfilling, supply and placement of pipe complete with all fittings, service reconnects, environmental protection and reinstatement up to and including Type 2 gravels as specified.

.2 Spot Repair

This item includes: excavation, removal and disposal of existing pipe within or partially within theoretical trench, bedding and backfilling, supply and placement of pipe (PVC DR35 diameter to match existing) complete with approved connection fittings (Unicouplings) and reinstatement up to and including Type 2 gravels as specified.

21. Pressure Pipe

Unit of Measurement: metre (m)

Method of Measurement: along centreline of pipe through fittings.

This item includes: excavation, removal and disposal of existing pipe within or partially within theoretical trench, bedding and backfilling, supply and placement of pipe complete with all fittings, corrosion protection, trace wire, test stations at 300 m intervals,

utility marker tape and reinstatement up to and including Type 2 gravels as specified.

22. Manholes

Unit of Measurement: Each

This item includes: excavation, removal and disposal of existing structure where existing structure is within or partially within excavation limits for new structure, bedding and backfilling, supply and placement of manholes as indicated and in accordance with Halifax Water Standard Details or as otherwise detailed on the drawings. Also includes adjustment to finished grade and reinstatement up to and including Type 2 gravels as specified.

23. Services

Unit of Measurement: Each

Method of Measurement: along centreline of pipe through fittings

This item includes: excavation, removal and disposal of existing pipes within or partially within theoretical trench, bedding and backfilling, supply and placement of pipe complete with all fittings, installation of prefabricated PVC in-line tee on new and existing sewer main, approved fittings at connection points and reinstatement up to and including Type 2 gravels as specified.

24. Connections to Existing Main

Unit of Measurement: Each

This item includes: locating existing line or structure, supply and installation of all fittings or manhole as indicated. This item also includes excavation, bedding, backfilling including Type 2 gravel as specified and reinstatement.

25. Closed Circuit Television Inspection

Unit of Measurement: metre (m) for each inspection.

Method of Measurement: along centreline of pipe through manholes.

This item includes: CCTV inspections, deflection testing, records and reports as described in Halifax Water Supplementary Standard Specification Section 33 01 30 CCTV Inspection.

Contractor to conduct two CCTV inspections 1) post construction, as referenced above, and 2) prior to the end of warranty period of two years.

26. Removal of Existing Structures

Unit of Measurement: Each or metre (m)

Method of Measurement: number of structures removed or horizontal measurement of pipe.

This item is intended for removal of pipes/structures that are outside of the theoretical trench or excavation limits for new pipes/structures and includes: locating existing pipe or structure, excavation, disposal, replacement of required volume with select material, backfilling and reinstatement up to and including Type 2 gravels as specified. This item also includes the capping of all remaining pipes or plugging of holes in structures and delivery of removed items as specified.

27. Reserved.

28. Reserved.

29. Reserved.

STORM SEWER

30. Pipe

Unit of Measurement: metre (m)

Method of Measurement: along centreline of pipe through manholes.

.1 Pipe

This item includes: excavation, removal and disposal of existing pipe within or partially within theoretical trench, bedding and backfilling, supply and placement of pipe complete with all fittings, service reconnects, environmental protection and reinstatement up to and including Type 2 gravels as specified.

.2 Spot Repair

This item includes: excavation, removal and disposal of existing pipe within or partially within theoretical trench, bedding and backfilling, supply and placement of pipe (PVC DR35 diameter to match existing) complete with approved connection fittings (Unicouplings) and includes clear stone,

geotextile as specified for underdrains, and reinstatement up to and including Type 2 gravels as specified.

.3 Perforated Pipe

This item includes: excavation, bedding and backfilling, supply and placement of pipe complete with all fittings, service reconnects, and environmental protection, and includes clear stone, geotextile as specified for underdrains, and reinstatement up to and including Type 2 gravels as specified. This item also includes connection to any existing household outfalls and connection to existing or proposed catch basins or manholes as required.

31. Manholes

Unit of Measurement: Each

This item includes: excavation, removal and disposal of existing structure where existing structure is within or partially within excavation limits for new structure, bedding and backfilling, supply and placement of manholes as indicated and in accordance with Halifax Water Standard Details or as otherwise detailed on the drawings. Also includes supply and installation of new frame and grate or cover hardware as specified, adjustment to finished grade and reinstatement up to and including Type 2 gravels as specified.

32. Installation of Catchbasins

Unit of Measurement: Each

Method of Measurement: number of units installed by type and size.

This item includes: excavation, removal and disposal of existing structure where existing structure is within or partially within excavation limits for new structure, bedding and backfilling, supply and placement of catchbasins as indicated and in accordance with Halifax Water Standard Details or as otherwise detailed on the drawing. Also includes supply and installation of new frame and grate or cover hardware as specified, adjustment to finished grade and reinstatement up to and including Type 2 gravels as specified.

33. Catchbasin Leads

Unit of Measurement: metre (m)

Method of Measurement: along centreline of pipe from centre of catchbasin to centre of main sewer, centre of manhole, or termination point indicated.

This item includes: excavation, removal and disposal of existing pipe within or partially within theoretical trench, bedding and backfilling, supply and placement of pipe complete with all fittings, connections and reinstatement up to and including Type 2 gravels as specified.

34. Services

Unit of Measurement: Each

This item includes: excavation, removal and disposal of existing pipes within or partially within theoretical trench, bedding and backfilling, supply and placement of pipe, bends and approved fittings at connection points and reinstatement up to and including Type 2 gravels as specified.

35. Connections to Existing Main

Unit of Measurement: Each

This item includes: locating existing line or structure and supply and installation of all fittings to catchbasin, or manhole as indicated. This item also includes excavation, bedding, backfilling including Type 2 gravel as specified and reinstatement.

36. Culverts

Unit of Measurement: metre (m)

Method of Measurement: along centreline of pipe.

This item includes: pipe, excavation and backfilling including Type 2 gravel as specified, pipe bedding and reinstatement.

37. Closed Circuit Television Inspection

Unit of Measurement: metre (m) for each inspection.

Method of Measurement: along centreline of pipe through manholes.

This item includes: CCTV inspections, deflection testing, records and reports. CCTV inspection is to be completed after all excavation for water main and sanitary and storm services are complete, and roadway is graveled and compacted for water main pressure test.

Copy of CCTV inspection and report shall be provided to Halifax Water for review prior to placement of asphalt.

Contractor to conduct two CCTV inspections 1) post construction, as referenced above, and 2) prior to the end of warranty period of two years.

38. Removal of Existing Structure

Unit of Measurement: Each or metre (m)

Method of Measurement: number of catchbasins or manholes removed or horizontal measurement of pipe.

This item is intended for removal of pipes/structures that are outside of the theoretical trench or excavation limits for new pipes/structures and includes: locating existing pipe or structure, excavation, disposal, replacement of required volume with select material, backfilling and reinstatement up to and including Type 2 gravels as specified. This item also includes the capping of all remaining pipes or plugging of holes in structures and delivery of removed items as specified.

39.1 Culvert Headwall

Unit of Measurement: lump sum (l.s.) or cubic metre (m³) or Each

Method of Measurement: volume of wall and footing constructed

This item includes: common excavation, granular base, supply and installation of headwall as specified, granular backfill, handrail, geosynthetic and all reinstatement.

39.2 Culvert Apron

Unit of Measurement: square metre (m²)

Method of Measurement: horizontal measurement

This item includes: excavation, supply and placement of geotextile and all materials to specified thickness.

39.3 Inlet / Outlet Grate / Structure

- .1 -- mm dia. Inlet Grate
.2 -- mm dia. Outlet Grate

Unit of Measurement: Each

This item includes: supply and placement of grate as specified.

.3 Inlet / Outlet Structure

Unit of Measurement: lump sum (l.s.)

This item includes: all labour and materials necessary to construct and install the inlet and/or outlet structures indicated in the project drawings. This includes, but is not limited to clearing, grubbing, common excavation, bedding, backfilling, rip-rap, geotextile, formwork, concrete reinforcing, railing and grate fabrication and installation, and connection or casting of pipe to structure.

39.4 Headwall Railing

Unit of Measurement: Each

This item includes: supply and installation of headwall railings as indicated in the project drawings. This includes but is not limited to common excavation, railing and grate fabrication and installation, including footings and fixings.

39.5 Ditch Cleaning

Unit of Measurement: metre (m)

This item includes: clearing brush, grubbing, cleaning ditches as described in the tender documents or as directed by the Engineer, 150 mm topsoil, and/or hydroseeding, and/or mulching as directed or as specified on the drawings to cover all areas that are disturbed by the ditching operation, removal and disposal of all excavated material, and clean-up activities, including hand work, to clean out culvert ends and around utilities.

Payment for ditching shall be at the contract unit bid price per linear metre and shall be full compensation for all materials, equipment, plant, labour, excavation, removal and disposal of excavated material, clean-up activities, traffic control, hydroseeding and/or mulching and all incidentals necessary to complete the work as specified.

39.6 Ditching

Unit of Measurement: metre (m)

This item includes: all excavation, grading, supply and installation of materials (including rip-rap) and removal and disposal of waste material (including vegetation) required to complete construction of ditching as specified in the tender drawings.

STREET
CONSTRUCTION40. Gravels

Unit of Measurement: square metre (m²) or tonne (t)

Method of Measurement: slope measure of indicated area at mean depth or scale tickets signed by Engineer.

This item includes: mass excavation and embankment – common, supply, placement and compaction of gravel as indicated.

40.23 Type 1 Trench Gravel – 150 mm40.24 Type 1 Trench Gravel – 200 mm

Unit of Measurement: square metre (m²) or tonne (t)

Method of Measurement: Average end area method between changes in trench cross section. Dimensions used to calculate end areas shall be theoretical trench width as per detail HWSD – 1000, and trench depth as indicated.

This item includes: mass excavation and embankment – common, supply, placement and compaction of gravel as indicated.

41. Placement Materials.1 Reinstatement Tape

Unit of Measurement: linear metre (m)

Method of Measurement: slope measure

This item includes: the supply and installation of 2 mm x 50 mm reinstatement tape at asphalt joint in street cut by method as specified by supplier.

.2 Bituminous Prime

Unit of Measurement: square metre (m²)

Method of Measurement: slope measure of surface area.

This item includes: supply and application.

.3 Glass Grid

Unit of Measurement: square metre (m²)

Method of Measurement: slope measure

This item includes: supply and placement of glass grid or equivalent, in accordance with HRM standard detail HRM 29 and manufacturer's recommendations. Separate payment will be made for the leveling course of asphalt if required.

.4 Crack Sealing

.1 Clean and Seal Operation

Unit of Measurement: linear metre (m)

Method of Measurement: slope measure

This item includes: cleaning and filling of cracks in asphalt concrete. All crack sealing works shall be limited to sealing uncut cracks with the Clean and Seal Operation as specified. The work consists of the furnishing of all materials, tools, equipment and labour required to complete the work, and all incidentals. Refer to Section S-15 for the Clean and Seal Operation. The Owner reserves the right to schedule the crack sealing locations based on priority.

.5 Geosynthetics

Unit of Measurement: square metre (m²)

Method of Measurement: slope measure.

Payment for geosynthetics will be made separately for each type of geosynthetics supplied and installed.

This item includes: supply and installation of geosynthetics and includes all equipment, labour and incidentals necessary to complete the work. Measurement of geosynthetics will be for the net surface of the work covered by the material. No additional payment will be made for

required overlapping of the material as per the manufacturer's recommendations.

Payment for geosynthetics associated with the retaining walls is included in the unit price for those items.

42. Asphaltic Concrete

.1 Asphaltic Concrete

Unit of Measurement: square metre (m²) or tonne (t)

Method of Measurement: slope measure of surface area or scale tickets signed by Engineer.

- .1 Type C-HF – 40 mm thick
- .2 Type C-HF – 50 mm thick
- .3 Type Special C – 40 mm thick
- .4 Type Special C – 50 mm thick
- .5 Type C-HF – 50 mm thick Polymer Modified
- .6 Type B-HF – 50 mm thick
- .7 Type B-HF – 60 mm thick
- .8 Type B-HF – 75 mm thick
- .9 Type B-HF – 100 mm thick
- .10 Type D-HF – 40 mm thick
- .11 Type D-HF – 50 mm thick
- .12 Type D-HF – 65 mm thick
- .13 Type D-HF – 75 mm thick
- .14 Type D-HF – 50 mm thick Polymer Modified
- .15 Type B-HF
- .16 Type C-HF
- .17 Type D-HF

This item includes: mass excavation and embankment – cleaning, supply, placement and compaction of asphaltic concrete as indicated including dry sweeping milled surfaces prior to tacking, tack coat, temporary pavement markings and saw cutting as necessary. This item also includes supply, placement and compaction of asphalt concrete ramps installed at all limits including side streets and pedestrian ramps using hot mix asphalt (or approved equivalent) and a bond separator. Refer to section S-1 for further details.

.2 Cold Planing

Unit of Measurement: square metre (m²)

This item includes: the supply of all necessary materials, labour and equipment required for the planing / profiling of asphaltic concrete to the depth specified, delivery of all milled material to a HRM designated site (East – Turner Drive, West – MacKintosh Street), cleaning of all milled surfaces, temporary pavement markings and all other work as designated by the Engineer. Profiler speed not to exceed 18.2 m/min (60 ft./min). This item also includes supply, placement and compaction of asphalt concrete ramps installed between the planed surface and the existing asphalt at all limits including side streets and pedestrian ramps using hot mix asphalt (or approved equivalent) and a bond separator. Refer to Section S-3 for further details.

.3 Asphaltic Concrete Miscellaneous

.1 Hand Patch

Unit of Measurement: square metre (m²) or tonne (t)

Method of Measurement: slope measure of surface area or scale tickets signed by Engineer.

This item includes: cleaning, dry sweeping milled surfaces prior to tacking, tack coat, supply, placement and compaction of asphaltic concrete as indicated. Refer to section S-1 for further details.

.2 Cut and Patch

Unit of Measurement: tonne (t)

Method of Measurement: slope measure of surface area or scale tickets signed by Engineer.

This item includes: mass excavation, cleaning, dry sweeping milled surfaces prior to tacking, tack coat, supply, placement and compaction of asphaltic concrete as indicated including temporary pavement markings and saw cutting as necessary. This item also includes 150 mm Type 1 gravel as per HRM Standard Details 59 and 60. Refer to section S-1 for further details.

.3 Planer Patch

Unit of Measurement: square metre (m²) or tonne (t)

Method of Measurement: slope measure of surface area or scale tickets signed by Engineer.

This item includes: mass excavation and embankment – common by planing, delivery of all milled material to a HRM designated site (East – Turner Drive, West – MacKintosh Street), cleaning, dry sweeping milled surfaces prior to tacking, tack coat, supply, mechanical placement and compaction of asphaltic concrete as indicated including temporary pavement markings and saw cutting as necessary. Refer to sections S-1 and S-3 for further details.

.4 Profile Correction

Unit of Measurement: tonne (t)

Method of Measurement: slope measure of surface area or scale tickets signed by Engineer.

This item includes: cleaning, dry sweeping milled surfaces prior to tacking, tack coat, supply, placement and compaction of asphaltic concrete as indicated including temporary pavement markings and saw cutting as necessary. Refer to section S-1 for further details.

.5 Spreader (Mechanical Paver) Patch

Unit of Measurement: square metre (m²) or tonnes (t)

Method of Measurement: slope measure of surface area or scale tickets signed by Engineer.

This item includes: mass excavation and embankment – common by planing, delivery of all milled material to a HRM designated site (East – Turner Drive, West – MacKintosh Street), cleaning, dry sweeping milled surfaces prior to tacking, tack coat, supply, placement and compaction of asphaltic concrete as indicated including temporary pavement markings, reinstatement tape, 150 mm Type 1 gravel and saw cutting as necessary as per HRM Standard Detail HRM 59 and HRM 60. Refer to section S-1 for further details.

.6 Full Depth Reclamation

Unit of Measurement: square metre (m²)

Method of Measurement: slope measure of surface area

This item includes but is not limited to: all labour, equipment and material required to undertake the work which includes excavation and pulverization of in-situ asphalt and gravels to depths indicated, supply and mixing of corrective aggregate (if necessary), grading and placement of reclaimed material. For the complete description of work required for this item see supplementary specifications S-8 Full Depth Reclamation.

.7-.10 In Place Stabilization

Unit of Measurement: square metre (m²)

Method of Measurement: slope measure.

This item includes but is not limited to: all labour, equipment and materials required to undertake the work, which includes injection of emulsion, mixing, grading, compaction, tack coat and temporary pavement markings. For the complete description of work required for this item see supplementary specifications S-8 Full Depth Reclamation.

.11 Asphalt Swale

Unit of Measurement: linear metre (m)

Method of Measurement: slope measure along centreline of swale

This item includes: mass excavation and embankment, dry sweeping milled surfaces prior to tacking, tack coat, supply, placement of asphalt swale as per detail drawing HRM 30 (by mechanical spreader, or by hand when not being installed in conjunction with a new lift of asphalt), compaction of asphalt concrete as indicated, temporary pavement markings and saw cutting as necessary. Refer to section S-1 for further details.

.12 Pulverization

Unit of Measurement: square metre (m²)

Method of Measurement: slope measure

This item includes but is not limited to: all labour, equipment and material required to undertake the work which includes pulverizing, initial grading and compaction. Maximum aggregate size of pulverized material shall be no greater than 50 mm. The contractor shall accurately take inventory of the existing roadway cross slope and reinstate as directed by the Engineer. This item also includes supply, placement and compaction of asphalt concrete ramps installed at all limits including side streets and pedestrian ramps using hot mix asphalt (or approved equivalent) and a bond separator. For the complete description of work required for this item see supplementary specifications S-8 Full Depth Reclamation.

.13 Full Depth Asphalt Removal

Unit of Measurement: square metre (m²)

This item includes: the supply of all necessary materials, labour and equipment required for the full depth asphaltic concrete removal and delivery of all milled material to the Contractor's location of choice. If asphaltic concrete is removed by planing, milled material may be delivered to a HRM designated site (East – Turner Drive, West – MacKintosh Street). This item also includes cleaning of all milled surfaces, temporary pavement markings and all other work as designated by the Engineer. This item also includes supply, placement and compaction of asphalt concrete ramps installed between the planed surface and the existing asphalt at all limits including side streets and pedestrian ramps using hot mix asphalt (or approved equivalent) and a bond separator.

.14 Micro Surfacing with Scratch Course

Unit of Measurement: square metre (m²)

Method of Measurement: slope measure of surface area

This item includes: supply, placement of scratch and final coat and compaction of asphaltic concrete of micro surfacing as indicated including cleaning, dry sweeping surfaces prior to tacking, tack coat, temporary pavement markings and saw cutting as necessary. Refer to section S-5 for further details.

.15 Single Chip Seal

Unit of Measurement: square metre (m²)

This item includes: all material, labour and equipment required to install a single chip seal as described in Section S-16, Chip Sealing for Streets.

.16 Double Chip Seal

Unit of Measurement: square metre (m²)

This item includes: all material, labour and equipment required to install a double chip seal as described in Section S-16, Chip Sealing for Streets.

.17 Full Depth Concrete Pavement Removal

Unit of Measurement: square metre (m²)

Method of Measure: slope measure

This item includes: the supply of all necessary materials, labour and equipment required for the full depth concrete pavement removal and delivery of all material to the Contractors location of choice. This item also includes steel reinforcing removal and cutting as required, cleaning of all milled surfaces, temporary pavement markings and all other work as designated by the Engineer. This item also includes supply, placement and compaction of asphalt concrete ramps installed between the planed or gravel surface and the existing asphalt at all limits including side streets and pedestrian ramps using hot mix asphalt (or approved equivalent) and a bond separator.

43. Curb

.1 Concrete Curb and Gutter

.2 Concrete Curb

Unit of Measurement: metre (m)

Method of Measurement: slope measure along face of curb through catchbasins.

Item 1 and 2 include: mass excavation and embankment – common, 150 mm Type 1 granular base (extended 150 mm beyond the back of the curb), grade stakes placed at the

curb alignment showing top of curb elevation at 10 m intervals (HRM approval required prior to placing curb and gutter (or concrete curb if specified), supply and installation of concrete curb and gutter (as per Standard Detail HRM 53) or concrete curb, and supply and placement of backfill to subgrade for topsoil, sidewalk or driveway. This item also includes the removal and disposal of the existing curb if the face of the proposed curb is within 1 m horizontally of the face of the existing curb.

.3 Asphalt Curb

Unit of Measurement: metre (m)

Method of Measurement: slope measure along face of curb through catchbasins.

This item includes: preparing surface on which the curb is to be placed so that it is dry and free from all loose and foreign material, placement of tack coat prior to curb placement, placing the asphalt curb as per Standard Detail HRM 55 by a machine (if the length of curb exceeds 10 m in a continuous length) that is self-powered and capable of extruding and compacting the asphalt concrete to the line, grade and cross-section as shown on the drawings or as otherwise specified. This item also includes the removal and disposal of the existing curb if the face of the proposed curb is within 1 m horizontally of the face of the existing curb.

.4 Curb Removal

Unit of Measurement: metre (m)

Method of Measurement: slope measure along face of curb through catchbasins.

This item includes: mass excavation and embankment – common, and supply and placement of backfill to subgrade.

.5 Pre-Cast Concrete Curb – Supply and Install

Unit of Measurement: each (ea.)

This item includes: preparing surface on which the pre-cast concrete curb is to be placed so that it is dry and free from all loose and foreign material and the supply and installation of pre-cast concrete curb including galvanized rebar and steel dowel anchors as per the tender drawings.

This item also includes installation of flexible delineators on proposed pre-cast concrete curb as shown in the drawings and as per manufacturer's instructions and cutting of curb to adjust lengths.

.6 Pre-Cast Concrete Curb – Install Only

Unit of Measurement: each (ea.)

This item includes: transport of each unit from the HRM MacKintosh Depot to the job site, preparing surface on which the pre-cast concrete curb will be placed so that it is dry and free from all loose and foreign material and installation of pre-cast concrete curb including galvanized rebar and steel dowel anchors as per the tender drawings. Asphalt shall be pre-drilled prior to installing dowels.

This item also includes installation of flexible delineators on proposed pre-cast concrete curb as shown in the drawings and as per manufacturer's instructions and cutting of curb to adjust lengths.

.7 Mountable Curb

Unit of Measurement: metre (m)

Method of Measurement: slope measure along face of curb.

This items includes: common excavation and embankment, 150 mm Type 1 granular base (extended 150 mm beyond the back of the curb), grade stakes placed at the curb alignment showing top of curb elevation at 10 m intervals (HRM approval required prior to placing curb and gutter or concrete curb if specified), and supply and placement of backfill to subgrade for topsoil, sidewalk or driveway as per Standard Detail HRM 53 and as specified on the drawings. This item also includes all curb steel reinforcing as specified.

44. Sidewalk

Unit of Measurement: square metre (m²)

Method of Measurement: slope measure.

This item includes: mass excavation and embankment – common, bedding sand as required, 150 mm Type 1 granular base (extended 150 mm beyond edge of sidewalk structure), sidewalk as per Tender Drawings, and supply and placement of backfill as indicated. This item also includes welded wire mesh when specified and jointing sand as required.

44.5 Asphalt Paths and Multi-Use Trails

Unit of Measurement: square metre (m²)

Method of Measurement: slope measure

This item includes: mass excavation and embankment – common, removal of existing asphalt, 150 mm Type 1 granular base (extended 150 mm beyond edge of sidewalk structure), asphalt path or multi-use trail as per tender Drawings, and supply and placement of backfill as indicated.

44.10 Concrete Unit Pavers

Unit of Measurement: square metre (m²)

Method of Measurement: slope measure

This item includes: mass excavation and embankment – common, bedding sand as required, 150 mm Type 1 granular base (extended 150 mm beyond edge of sidewalk structure), concrete base and drains as per details, and supply and placement of pre-cast concrete unit pavers. This item also includes welded wire mesh when specified and jointing sand as required.

44.12 Concrete or Asphalt Sidewalk Removal

Unit of Measurement: square metre (m²)

Method of Measurement: slope measure

This item includes: mass excavation and embankment – common, removal and disposal of existing concrete sidewalk, asphalt sidewalk, asphalt path, or multi-use trail as per tender Drawings, supply and placement of backfill as indicated, and reinstatement.

44.15 Traffic Island

Unit of Measurement: square metre (m²)

Method of Measurement: slope measure

This item includes: common excavation and embankment, 150 mm Type 1 granular base, doweling into adjacent curb, concrete traffic island placement as per Standard Detail HRM 52, and supply and placement of backfill as indicated. This item also includes welded wire mesh when specified.

45. Retaining Wall

Unit of Measurement: cubic metre (m³) or square metre (m²)

Method of Measurement: volume of wall and footing constructed or area of wall face above footing.

.1 Retaining Wall Including Reinstatement

This item includes: design of the walls to suit dimensions and design criteria shown on tender drawings, supply of shop drawings for review, revision and preparation of construction drawings to incorporate review comments, supply and installation of wall materials including pre-cast concrete wall components, geosynthetic, granular backfill, topsoil 300 mm thick, sod, geogrid, drains as indicated, common excavation, granular base, and associated reinstatement.

This item also includes sealed drawings and certification of finished retaining wall construction including the base gravels, by a Professional Engineer (P.Eng.) licensed to practice in Nova Scotia.

.2 Retaining Wall Excluding Reinstatement

This item includes: design of the walls to suit dimensions and design criteria shown on tender drawings, supply of shop drawings for review, revision and preparation of construction drawings to incorporate review comments, supply and installation of wall materials including pre-cast concrete wall components, geosynthetic, granular backfill, geogrid, drains as indicated, common excavation, and granular base.

This item also includes sealed drawings and certification of finished retaining wall construction including the base gravels, by a Professional Engineer (P.Eng.) licensed to practice in Nova Scotia.

46. Traffic Sign Base.1 Urban Traffic Sign Post

Unit of Measurement: Each

This item includes: common excavation, backfill, supply and installation of concrete, reinforcing steel, iron pipe sleeve, sign post and water tight cap as per Standard Detail HRM

38. This item also includes surface reinstatement to original condition or better.

This item does not include the supply and installation of signs. If applicable, this item also includes the temporary connection of the removed sign post (and sign) to the new sign post.

.2 Rural Traffic Sign Post

Unit of Measurement: Each

This item includes: common excavation, backfill, supply and installation of telespar sign post and two piece breakaway anchor as per Standard Detail HRM 39. This item also includes surface reinstatement to original condition or better.

This item does not include the supply and installation of signs. If applicable, this item also includes the temporary connection of the removed sign post (and sign) to the new sign post.

.3 Remove Sign Post and Base

Unit of Measurement: Each

This item includes: common excavation, backfill, removal and disposal of existing sign post and base, and all reinstatement as required including landscaping.

.4 Traffic Sign Post at Curb End Unit

Unit of Measurement: Each

This items includes: supply and installation of sign post with water tight cap at pre-cast curb end units as indicated on the Drawings including all associated hardware. This item does not include the supply and installation of signs.

.5 Urban Traffic Sign Installation

Unit of Measurement: Each

This item is to be used in conjunction with line item 46.1 – Urban Traffic Sign Post.

This item includes transportation of the proposed signage from the MacKintosh Depot, the supply of all required

hardware and accessories for sign installation, installation of the sign, and welding of the post, all as per standard detail HRM 129.

.6 Rural Traffic Sign Installation

Unit of Measurement: Each

This item is to be used in conjunction with line item 46.2 – Rural Traffic Sign Post.

This item includes transportation of the proposed signage from the MacKintosh Depot, the supply of all required hardware and accessories for sign installation, and installation of the sign, all as per standard detail HRM 130.

.7 Utility Pole Sign Installation

Unit of Measurement: Each

This item is to be used when installing a sign on a utility pole.

This item includes transportation of the proposed signage from the MacKintosh Depot, the supply of all required hardware and accessories for sign installation, and installation of the sign, all as per standard detail HRM 130.

47.1 Adjust Existing Structures to Grade

.1 Shaft Adjustment (Manhole)

Unit of Measurement: Each

Method of Measurement: number of existing manholes adjusted to grade.

This item includes: excavation and backfill, removal of existing shaft section (800 mm inside diameter or less), reconstruction with pre-cast concrete sections and cast-in-place concrete as specified, setting of frame and cover to finished grade and reinstatement to match existing.

This item also includes the placement of catchment devices in all manholes prior to work commencing on the manhole, and the removal thereof after all work is completed. This item also includes the removal and disposal of all debris accumulated during construction.

.2 Shaft and Intermediate Section Adjustment (Manhole)

Unit of Measurement: Each

Method of Measurement: number of existing manholes adjusted to grade.

This item includes: excavation and backfill, removal of existing shafting material, eccentric cone sections and intermediate sections, supply and installation of required pre-cast concrete sections, supply and placement of cast-in-place concrete as specified, setting of frame and cover to finished grade and reinstatement to match existing.

This item also includes the placement of catchment devices in all manholes prior to work commencing on the manhole, and the removal thereof after all work is completed. This item also includes the removal and disposal of all debris accumulated during construction.

.3 Shaft Adjustment (Catchbasin)

Unit of Measurement: Each

Method of Measurement: number of existing catchbasins adjusted to grade

This item includes: excavation and backfill, removal of existing adjusting section on top of capping section, reconstruction with cast-in-place concrete as specified, setting of frame and grate to finished grade and reinstatement to match existing. This item also includes the removal and disposal of all debris accumulated during construction.

.4 Shaft and Intermediate Section Adjustment (Catchbasin)

Unit of Measurement: Each

Method of Measurement: number of existing manholes adjusted to grade.

This item includes: excavation and backfill, removal of existing shafting material, eccentric cone sections and intermediate sections, supply and installation of required pre-cast concrete sections, supply and placement of cast-in-place concrete as specified, setting of frame and grate to finished grade and reinstatement to match existing. This

item also includes the removal and disposal of all debris accumulated during construction.

.5 Type 1 Water Valve Adjustment

Unit of Measurement: Each

Method of Measurement: number of existing water valves adjusted to grade.

This item includes: the supply and installation of adjustable top and cap, excavation and adjustment of adjustable top, setting top to finished grade and reinstatement to match existing. Materials and specifications as per Halifax Water Supplementary Standard Specification, Section 33 11 00.

This item also includes the removal and disposal of all debris accumulated during construction.

.6 Type 2 Water Valve Adjustment

Unit of Measurement: Each

Method of Measurement: number of existing water valves adjusted to grade.

This item includes: excavation and adjustment of upper valve box extension sleeve, setting top to finished grade and reinstatement to match existing. This item also includes the removal and disposal of all debris accumulated during construction.

Materials and specifications as per Halifax Water Supplementary Standard Specification, Section 33 11 00.

.7 Type 3 Water Valve Adjustment

Unit of Measurement: Each

Method of Measurement: number of existing water valves adjusted to grade.

This item includes: the supply and installation of upper valve box and cap (and intermediate section if required); excavation and adjustment of upper valve box extension sleeve; centering over the valve operating stem, setting top to finished grade and reinstatement to match existing. This item also includes the removal and disposal of all debris accumulated during construction.

Materials and specifications as per Halifax Water Supplementary Standard Specification, Section 33 11 00.

.8 Type 4 Water Valve Adjustment

Unit of Measurement: Each

Method of Measurement: number of existing water valves adjusted to grade.

This item includes: the supply and installation of both the upper, intermediate, and lower valve box sections and cap, excavation, adjustment and replacement of upper valve box extension sleeve.

Item also includes the centering of the new valve box sections over the valve operating nut, the setting of the top to finished grade and reinstatement to match existing. This item also includes the removal and disposal of all debris accumulated during construction.

Materials and specifications as per Halifax Water Supplementary Standard Specification, Section 33 11 00.

47.2 Replace Frames and Grates or Covers (Including Final Grade Adjustment)

Unit of Measurement: Each

Method of Measurement: Number of sets of frame and grate or cover

This item includes: excavation and backfill, removal of existing shaft section (800 mm inside diameter or less), supply and installation of new adjustable frame and grate or cover as specified, reconstruction with pre-cast sections and cast-in-place concrete as specified, setting of frame and cover to finished grade and reinstatement to match existing.

This item also includes the placement of catchment devices in all manholes prior to work commencing on the manholes, and the removal thereof after all work is completed. This item also includes the removal and disposal of all debris accumulated during construction.

47.3 Adjust Existing Adjustable Frames and Covers

Unit of Measurement: Each

Method of Measurement: Number of sets of frame and cover

This item includes: adjustment of adjustable frame and cover to finished grade and reinstatement to match existing. This item also includes the removal and disposal of all debris accumulated during construction.

47.4 Adjust Existing Adjustable Frames and Covers (Micro surfacing)

Unit of Measurement: Each

Method of Measurement: Number of sets of frame and cover

This item includes: adjustment of adjustable frame and cover to finished grade and reinstatement to match existing for micro surfacing and/or thin lifts of asphalt paving. This item also includes the removal and disposal of all debris accumulated during construction.

48. Type 2 Gravel or Surge Rock Below Subgrade

Unit of Measurement: cubic metre (m³) or tonne (t)

Method of Measurement: average end area method or scale tickets signed by Engineer.

This item includes: excavation and disposal of unsuitable material below subgrade and supply, placement and compaction of gravel or surge rock and filter fabric as directed by Engineer.

49. Driveway Reinstatement

.1 Gravel

Unit of Measurement: tonne (t)

Method of Measurement: scale tickets signed by Engineer.

This item includes: excavation, supply, placement and compaction of Type 1 gravel (150 mm minimum thickness).

.2 Asphalt

Unit of Measurement: square metre (m²)

Method of Measurement: Slope measure or scale tickets signed by Engineer.

This item includes: excavation, supply, placement and compaction of Type D-HF asphalt as specified. It also includes excavation, supply, placement and compaction of 150 mm Type 1 gravel base and reinstatement tape along cut edge of existing asphalt.

- .1 65 mm Type D asphalt
- .2 90 mm Type D asphalt
- .3 40 mm Type D asphalt

.3 Concrete

Unit of Measurement: square metre (m²)

Method of Measurement: Slope measure

This item includes: excavation, supply, placement and finishing of 150 mm thick concrete including welded wire mesh and installation of 200 mm long 10M dowels into the existing driveway at 600 mm c.c. It also includes excavation, supply, placement and compaction of 150 mm Type 1 gravel base.

.4 Brick Paver

Unit of Measurement: square metre (m²)

Method of Measurement: Slope measure

This item includes: excavation, supply and placement of brick pavers to reinstate existing brick work to original condition. This item also includes supply, placement and compaction of 150 mm Type 1 gravel, bedding sand and jointing material.

.5 Exposed Aggregate

Unit of Measurement: square metre (m²)

Method of Measurement: Slope measure or scale tickets signed by Engineer.

This item includes: excavation, supply, placement and finishing of 150 mm thick concrete (match existing aggregate size and colour) including welded wire mesh. It also includes 150 mm Type 1 gravel base, the supply and installation of 10M dowels into the existing driveway at 600 mm c.c. and sealant. Refer to Section S-9 for further details.

LANDSCAPING50. Topsoil and Sod.1 150 mm Topsoil and Sod

Unit of Measurement: square metre (m²)

Method of Measurement: slope measure.

This item includes: excavation, scarification of the existing soil, supply 150 mm topsoil, lime, fertilizer, sod, required accessories, and maintenance.

.2 Topsoil

Unit of Measurement: cubic metre (m³) or tonne (t)

Method of Measurement: average end area method or scale tickets signed by Engineer.

This item includes: excavation and disposal of unsuitable material and supply and placement of topsoil as directed.

51. Topsoil and Seed.1 150 mm Topsoil and Seed

Unit of Measurement: square metre (m²)

Method of Measurement: slope measure.

This item includes: excavation, scarification of the existing soil, supply 150 mm topsoil, compaction, lime, fertilizer, mulch, erosion control agent, seed, and maintenance.

.2 Topsoil

Unit of Measurement: cubic metre (m³) or tonne (t)

Method of Measurement: average end area method or scale tickets signed by Engineer.

This item includes: excavation and disposal of unsuitable material and supply and placement of topsoil as directed.

52. Trees, Shrubs and Groundcover

Unit of Measurement: Each or square metre (m²)

Method of Measurement: Individual item or slope measure

This item includes: supply and installation of trees, shrubs and groundcover, planting mixture, mulch, lime and fertilizer, tree supports and accessories and maintenance as specified.

53. Hydroseed

Unit of Measurement: square metre (m²)

Method of Measurement: slope measure

This item includes: topsoil as specified, hydroseed mix, mulch, erosion control agent, water and fertilizer as specified and maintenance.

54. Tree Removal

Unit of Measurement: Each or lump sum (l.s.)

This item includes: mass excavation and embankment – common, removal and disposal of all trees including stumps and roots (to size indicated) as indicated on plan, backfill, and all reinstatement. Tree diameter shall be measured at 1.3 m from the ground.

54.5 Tree Trimming

Unit of Measurement: lump sum (l.s.)

This item includes: the careful trimming of trees and brush by a certified arborist.

All tree trimming and pruning should be completed prior to April 15th or succeeding August 31st. If this is not possible a Migratory Bird Assessment is required, and the contractor must provide the HRM Engineer with 48-hour notice prior to any work being conducted.

54.6 Migratory Bird Assessment

Unit of Measurement: lump sum (l.s.)

If tree trimming, pruning, or removal is required within the April 15th to August 31st timeframe, the contractor shall engage a Professional Ornithologist and must conduct an assessment to determine the presence of any nesting of migratory birds within the proposed limits of work and provide documentation thereof.

This item includes all labour, fees, and materials required to conduct this assessment and to provide the required documentation.

55. Chip Trees in Place

Unit of Measurement: Each or lump sum (l.s.)

This item includes: removal of trees, chipping on site and distributing on site as specified by Engineer.

56. Bark Mulch

Unit of Measurement: square metre (m²)

Method of Measurement: slope measure

This item includes: excavation, supply 100 mm thick bark mulch and non-woven filter fabric.

57. Handrails and Fences

Unit of Measurement: metre (m) or each (ea)

Method of Measurement: slope measure along top rail.

This item includes: excavation and backfill, removal and disposal of existing fence, bollards, gates and/or footings, supply and placing concrete footings, installation and finishing of posts, rails, gates, fabric, fittings, bollards, and accessories as per the Tender Drawings, temporary measures as required, and surface reinstatement as specified.

58. Tree Stump Removal

Unit of Measurement: Each

This item includes: mass excavation and embankment – common, cutting roots as required, removal and disposal of the tree trunk, removal and disposal of roots as directed, supply and placement of borrow as required to fill in all voids, 150 mm of topsoil and sod (if an individual pay item is not provided), lime, fertilizer, required accessories and maintenance.

59. Soil Cells

Unit of Measurement: cubic metre (m³)

Method of Measurement: volume (measured at perimeter of soil cells)

This item includes: mass excavation and embankment – common, supply and install of soil cells including all required materials and accessories, including but not limited to geotextile, geogrids, aggregates, subbase material, specified soil mixture, drainage system, and root barrier as required, all as per the Tender Drawings and manufacturer details and specifications. This item also includes existing pipe and conduit protection, backfill, and Type 2 gravels as specified. Refer to Section 32 94 50 Structural Soil Cells for further information.

ADDITIONAL
ITEMS

60. Trench Excavation – Rock

Unit of Measurement: cubic metre (m³) or tonne (t)

Method of Measurement:

Average end area method between changes in rock cross section. Dimensions used to calculate end areas shall be theoretical trench width as per detail HWSD – 1000, and depth from surface of rock as exposed on sides of trench after excavation to bottom of specified bedding for each pipe in trench.

Boulders larger than one-half cubic metre, any portion of which is within theoretical trench, will be classified as rock. Boulders removed from trench shall be measured along the three maximum perpendicular axes.

This item includes: all incidental work for rock excavation and disposal of surplus material over and above cost of common excavation which is included in price for pipe and related items. Also includes replacement of required volume with select material.

61. Trench Excavation – Unsuitable Material

Unit of Measurement: cubic metre (m³) or tonne (t)

Method of Measurement: average end area method for volume of unsuitable material less theoretical trench volume or ticket of surge material used to backfill.

This item includes: all excavation of unsuitable material beyond limits of the theoretical trench as per detail HWSD – 1000, and disposal. Written authorization of Engineer required.

62. Replacement of Unsuitable Trench Material with Type 2 Gravel or Surge Rock

Unit of Measurement: cubic metre (m³) or tonne (t)

Method of Measurement: average end area method for volume of unsuitable material less theoretical trench volume or ticket of surge material.

This item includes: placing Type 2 gravel or surge rock in locations where unsuitable material has been excavated from the trench beyond the limits of the theoretical trench as per detail HWSD – 1000. It also includes compaction of the gravel and placement of filter fabric. Written authorization of Engineer required.

63. Topsoil Excavation

Unit of Measurement: cubic metre (m³).

Method of Measurement: average end area method between cross sections taken before and after stripping topsoil.

This item includes: stripping and stockpiling or disposal of topsoil as directed.

64. Breaking Trench Rock Without Removal

Unit of Measurement: cubic metre (m³).

Method of Measurement: average end area method between changes in rock cross section. Dimensions used to calculate end areas to be theoretical trench width as per detail HWSD – 1000, and depth from surface of rock as encountered during drilling to the lines and elevations indicated.

This item includes: breaking of rock to size indicated and excavation and backfilling test holes.

65.1 Painted Markings

- .1 Painted Lines
- .2 Painted Stop Bars
- .3 Painted Yield Line

Unit of Measurement: metre (m)

Method of Measurement: slope measurement

This item includes: accurate inventory of existing pavement markings, the supply and application of paint in the colours, sizes, and configurations shown on the drawings and as specified by the Engineer. Also includes layout and pre-marking in accordance with S-1.

.4 Painted Crosswalks

Unit of Measurement: metre (m)

Method of Measurement: average of the slope measurement of both lines

This item includes: accurate inventory of existing pavement markings, the supply and application of paint in the colours, sizes and configurations shown on the drawings and as specified by the Engineer. Also includes layout and pre-marking in accordance with S-1.

.5 Painted Zebra Crosswalk

Unit of Measurement: metre (m)

Method of Measurement: slope measurement

This item includes: accurate inventory of existing pavement markings, the supply and application of paint in the colours, sizes, and configurations shown on the drawings and as specified by the Engineer. Also includes layout and pre-marking in accordance with S-1.

.6 Painted Hatching-White

.7 Painted Hatching-Yellow

Unit of Measurement: square metre (m²)

Method of Measurement: slope measure of surface area including perimeter line.

This item includes: accurate inventory of existing pavement markings, the supply and application of paint in the colours, sizes and configurations shown on the drawings and as specified by the Engineer. Also includes layout and pre-marking in accordance with S-1.

.8 Painted Intersection Box (Hatched)

Unit of Measurement: square metre (m²)

Method of Measurement: plan measurement

This item includes: accurate inventory of existing pavement markings, the supply and application of paint in the colours, sizes and configurations shown on the drawings and as

specified by the Engineer. Also includes layout and pre-marking in accordance with S-1.

.9 Painted Arrows

.1 Painted Arrow $\frac{3}{4}$ TAC size

.2 Painted Arrow $\frac{1}{2}$ TAC size

.3 Painted Roundabout Arrow

Unit of Measurement: Each

Method of Measurement: number of units installed. Where there is more than one arrow per installation (i.e., "Thru-left" symbol) this shall be counted as one unit.

This item includes: accurate inventory of existing arrows and configurations, supply and application of arrows in the colours, sizes and configurations shown on the drawings and as specified by the Engineer. Also includes layout and pre-marking in accordance with S-1.

.10 Painted Bicycle Symbol

Unit of Measurement: Each

Method of Measurement: number of units installed.

This item includes: accurate inventory of existing arrows and configurations, supply and application of bicycle pavement markings in colours, sizes and configurations shown on the drawings and as specified by the Engineer. Also includes layout and pre-marking in accordance with S-1.

.11 Painted Advance Yield to Pedestrian Line

Unit of Measurement: metre (m)

Method of Measurement: slope measurement

This item includes: accurate inventory of existing pavement markings, the supply and application of paint in colours, sizes and configurations shown on the drawings and as specified by the Engineer. Also includes layout and pre-marking in accordance with S-1.

.12 Painted Speed Hump/Table Markings

Unit of Measurement: Per speed hump/table location

Method of Measurement: number of speed humps/tables installed.

This item includes: accurate inventory of existing pavement markings, the supply and application of paint in colours, sizes and configurations shown on the drawings and as specified by the Engineer. Also includes layout and pre-marking in accordance with S-1.

.13 Painted Reserved Lane Diamond Symbol-White.

.14 Painted Shared Use Lane

Unit of Measurement: Each

This item includes: accurate inventory of existing pavement markings, the supply and application of symbols in the colours, sizes and configurations shown on the drawings and as specified by the Engineer. Also includes layout and pre-marking in accordance with S-1.

.16 Painted Speed Cushion Markings

Unit of Measurement: Per speed cushion

This item includes: accurate inventory of existing pavement markings, the supply and application of paint in colours, sizes and configurations shown on the drawings and as specified by the Engineer. Also includes layout and pre-marking in accordance with S-1.

.18 Painted Vehicle/Bike Zebra Conflict Marking, 1.8m x 0.6m
Total (1.5m Green With 0.15m White Each End)

Unit of Measurement: each (ea.)

This items includes: accurate inventory of existing pavement markings, the supply and application of paint in the colours, sizes and configurations shown on the drawings and as specified by the Engineer. Also includes layout and pre-marking in accordance with S-1.

.19 Painted Driveway/Bike Zebra Conflict Marking, 1.3m x 0.6m
Total (1.0m Green with 0.15m White Each End)

Unit of Measurement: each (ea.)

This item includes: accurate inventory of existing pavement markings, the supply and application of paint in colours, sizes and configurations shown on the Drawings, as

specified by the Engineer and as per HRM Red Book detail HRM 190 (using paint instead of thermoplastic). Also includes layout and pre-marking in accordance with S-1.

.21 Painted Trail Crosswalk Markings

Unit of Measurement: metre (m)

Method of Measurement: slope measurement

This item includes: accurate inventory of existing pavement markings, the supply and application of paint in colours, sizes and configurations shown on the Drawings, as specified by the Engineer and as per HRM Red Book detail HRM 93. Also includes layout and pre-marking in accordance with S-1.

.30 Painted New Intersection Markings

Unit of Measurement: lump sum (l.s.)

This item includes: supply and application of paint in the colours, sizes and configuration as indicated on the plan.

.31 Removal of Existing Painted Markings

Unit of Measurement: square metre (m²), Each or lump sum (l.s.)

Method of Measurement: Plan Measurement, per item or as Lump Sum

This item includes: the supply and installation of all materials required to remove the pavement markings in the configuration shown on the drawing and as specified by the Engineer.

.32 Replacement of Existing Painted Markings

Unit of Measurement: lump sum (l.s.)

This item includes: accurate inventory of existing pavement markings and the supply and application of paint in the colours, sizes and configuration as necessary to replace the markings which existed prior to construction. Also includes layout and pre-marking in accordance with S-1.

.34 Painted Pedestrian/Bicycle Shared Use Symbol

Unit of Measurement: each (ea.)

Method of Measurement: number of units installed.

This item includes: supply and application of pedestrian/bicycle shared use pavement markings in colours, sizes and configurations shown on the drawings and as specified by the Engineer. Also includes layout and pre-marking in accordance with S-1.

.35 Replacement of Existing Painted Markings

Unit of Measurement: metre (m)

Method of Measurement: slope measurement

This item includes: the supply and application of paint in the colours, sizes, and configurations shown on the drawings and as specified by the Engineer. Also includes layout and pre-marking in accordance with S-1.

65.2 Thermoplastic Markings

.1 Thermoplastic Lines

.2 Thermoplastic Stop Bars

.3 Thermoplastic Yield Line

.4 Thermoplastic Crosswalk

.5 Thermoplastic Zebra Crosswalk

Unit of Measurement: metre (m)

Method of Measurement: slope measure

This item includes: supply and application of preformed thermoplastic markings in the materials, colors, and sizes as specified on the Drawings and in accordance with Manufacturer's instructions. This also includes layout, pre-marking, asphalt surface preparation including milling (< 5 mm), adhesion to pavement, inspection and maintenance during warranty period. The surface of the preformed thermoplastic material shall contain factory applied anti-skid/anti-slip and retro-reflective elements.

.6 Thermoplastic Hatching-White

.7 Thermoplastic Hatching-Yellow

Unit of Measurement: square metre (m²)

Method of Measurement: slope measure of surface area including perimeter line.

This item includes: supply and application of preformed thermoplastic markings in the materials, colors, and sizes as specified on the Drawings and in accordance with Manufacturer's instructions. This also includes layout, pre-marking, asphalt surface preparation including milling (< 5 mm), adhesion to pavement, inspection and maintenance during warranty period. The surface of the preformed thermoplastic material shall contain factory applied anti-skid/anti-slip and retro-reflective elements.

.8 Thermoplastic Intersection Box (Hatched)

Unit of Measurement: square metre (m²)

Method of Measurement: plan measurement

This item includes: supply and application of preformed thermoplastic markings in the materials, colors, and sizes as specified on the Drawings and in accordance with Manufacturer's instructions. This also includes layout, pre-marking, asphalt surface preparation including milling (< 5 mm), adhesion to pavement, inspection and maintenance during warranty period. The surface of the preformed thermoplastic material shall contain factory applied anti-skid/anti-slip and retro-reflective elements.

.9 Thermoplastic Arrows

.1 Thermoplastic Arrow $\frac{3}{4}$ TAC size

.2 Thermoplastic Arrow $\frac{1}{2}$ TAC size

.3 Thermoplastic Roundabout Arrow

Unit of Measurement: Each

Method of Measurement: number of units installed

This item includes: supply and application of preformed thermoplastic markings in the materials, colors, and sizes as specified on the Drawings and in accordance with Manufacturer's instructions. This also includes layout, pre-marking, asphalt surface preparation including milling (< 5 mm), adhesion to pavement, inspection and maintenance during warranty period. The surface of the preformed thermoplastic material shall contain factory applied anti-skid/anti-slip and retro-reflective elements.

.10 Thermoplastic Bicycle Symbols

- .1 Thermoplastic Bicycle Symbol 1.2m x 2.1m, White on Black Background
- .2 Thermoplastic Bicycle Symbol 1.2m x 2.1m, White on Green Background
- .3 Thermoplastic Bicycle Symbol 0.6m x 1.2m, White on Green Background

Unit of Measurement: Each

Method of Measurement: number of units installed

This item includes: supply and application of preformed thermoplastic markings in the materials, colors, and sizes as specified on the Drawings and in accordance with Manufacturer's instructions. This also includes layout, pre-marking, asphalt surface preparation including milling (< 5 mm), adhesion to pavement, inspection and maintenance during warranty period. The surface of the preformed thermoplastic material shall contain factory applied anti-skid/anti-slip and retro-reflective elements.

.11 Thermoplastic Advance Yield to Pedestrian Line

Unit of Measurement: metre (m)

Method of Measurement: slope measure

This item includes: supply and application of preformed thermoplastic markings in the materials, colors, and sizes as specified on the Drawings and in accordance with Manufacturer's instructions. This also includes layout, pre-marking, asphalt surface preparation including milling (< 5 mm), adhesion to pavement, inspection and maintenance during warranty period. The surface of the preformed thermoplastic material shall contain factory applied anti-skid/anti-slip and retro-reflective elements.

.12 Thermoplastic Speed Hump/Table Markings

Unit of Measurement: Per speed hump/table location

Method of Measurement: number of speed humps/tables installed.

This item includes: supply and application of cold plastic markings in the materials, colors, and sizes as described

above, as specified on HRM Standard Drawing 96 in accordance with Manufacturer's instructions. This also includes layout, pre-marking, asphalt surface preparation including milling (< 5 mm), adhesion to pavement, inspection and maintenance during warranty period. The surface of the preformed thermoplastic material shall contain factory applied anti-skid and anti-slip elements.

.13 Thermoplastic Reserved Lane Diamond Symbol, White on Black Background

Unit of Measurement: Each

This item includes: supply and application of preformed thermoplastic markings in the materials, colors, and sizes as specified on the Drawings and in accordance with Manufacturer's instructions. This also includes layout, pre-marking, asphalt surface preparation including milling (< 5 mm), adhesion to pavement, inspection and maintenance during warranty period. The surface of the preformed thermoplastic material shall contain factory applied anti-skid/anti-slip and retro-reflective elements.

.14 Thermoplastic Reserved Lane Diamond Symbol, White on Red Background

Unit of Measurement: Each

This item includes: the supply and application of cold plastic markings in the materials, colours, sizes and configurations shown on the drawings, in accordance with the MUTCD, and as specified by the Engineer. Cold plastic pavement markings shall include a reserved lane (diamond) symbol enclosed within a red contrast panel as per as per HRM Standard Detail 134 and shall be applied in accordance with Manufacturer's instructions.

This item also includes layout and pre-marking in accordance with S-1, asphalt surface preparation, adhesion to pavement, inspection and maintenance during warranty period. The surface of the preformed thermoplastic material shall contain factory applied anti-skid and anti-slip elements.

PreMark ViziGrip highskid surface panels by Ennis-Flint Products (or approved equivalent) can be used contingent on the Engineers approval.

.15 Thermoplastic Shared Use Lane Symbol 1.0m x 3.1m

.1 Thermoplastic Shared Use Lane Symbol, White on Black Background

.2 Thermoplastic Shared Use Lane Symbol, White on Green Background

Unit of Measurement: Each

Method of Measurement: number of units installed

This item includes: supply and application of cold plastic markings in the materials, colors, and sizes as described above, as specified by the Engineer and in accordance with Manufacturer's instructions. This also includes layout, pre-marking, asphalt surface preparation including milling (< 5 mm), adhesion to pavement, inspection and maintenance during warranty period. Arterials shall have the pre-markings applied immediately after the placement of each lift of asphaltic concrete and permanent markings shall be applied within 48 hours. All other streets shall have the permanent markings applied within one week after the placement of the final lift of asphaltic concrete. The surface of the preformed thermoplastic material shall contain factory applied anti-skid and anti-slip elements.

.16 Thermoplastic Shark Teeth 450mm x 150mm, 5 per row

Unit of Measurement: Row

Method of Measurement: number of rows installed

This item includes: supply and application of preformed thermoplastic markings in the materials, colors, and sizes as specified on the Drawings and in accordance with Manufacturer's instructions. This also includes layout, pre-marking, asphalt surface preparation including milling (< 5 mm), adhesion to pavement, inspection and maintenance during warranty period. The surface of the preformed thermoplastic material shall contain factory applied anti-skid/anti-slip and retro-reflective elements.

.17 Thermoplastic Two Stage Left Turn Waiting Box, 2m x 3m, White on Green Background

Unit of Measurement: Each

This item includes: supply and application of cold plastic markings in the materials, colors, and sizes as specified on

the Drawings and in accordance with Manufacturer's instructions. This also includes layout, pre-marking, asphalt surface preparation including milling (< 5 mm), adhesion to pavement, inspection and maintenance during warranty period. The surface of the preformed thermoplastic material shall contain factory applied anti-skid and anti-slip elements.

- .18 Thermoplastic Vehicle/Bike Zebra Conflict Marking, 1.8m x 0.6m total (1.5m green with 0.15m white ea. End)
- .19 Thermoplastic Driveway/Bike Zebra Conflict Marking, 1.3m x 0.6m total (1.0m green with 0.15m white ea. End)
- .20 Thermoplastic Bike/Pedestrian Zebra Conflict Marking, 2.5m long x 1.5m wide, 0.3m white, 0.3m space

Unit of Measurement: metre (m)

Method of Measurement: slope measurement

This item includes: supply and application of Ennis-Flint Durable PreMark EF Bike Lane cold plastic markings in the materials, colors, sizes, and configurations as specified on the Drawings and in accordance with Manufacturer's instructions. This also includes layout, pre-marking, asphalt surface preparation including milling (< 5 mm), adhesion to pavement, inspection and maintenance during warranty period. The surface of the preformed thermoplastic material shall contain factory applied anti-skid and anti-slip elements.

- .21 Thermoplastic Trail Crosswalk Markings

Unit of Measurement: metre (m)

Method of Measurement: slope measurement

This item includes: supply and application of cold plastic markings in the materials, colors, and sizes as described above, as specified by the Engineer and in accordance with Manufacturer's instructions. This also includes layout, pre-marking, asphalt surface preparation including milling (< 5 mm), adhesion to pavement, inspection and maintenance during warranty period. The surface of the preformed thermoplastic material shall contain factory applied anti-skid and anti-slip elements.

- .22 Thermoplastic Modified Two Stage Left Turn Bike Box, 1.8m x 2.6m, White on Green Background

Unit of Measurement: each (ea.)

This items includes: supply and application of preformed thermoplastic markings in the materials, colors, and sizes as specified on the Drawings and in accordance with Manufacturer's instructions. This also includes layout, pre-marking, asphalt surface preparation including milling (< 5 mm), adhesion to pavement, inspection and maintenance during warranty period. The surface of the preformed thermoplastic material shall contain factory applied antiskid/anti-slip and retro-reflective elements.

.23 Thermoplastic White Single Line 300 mm wide, 3 m Spacing

Unit of Measurement: metre (m)

Method of Measurement: slope measure

This item includes: supply and application of preformed thermoplastic markings in the materials, colors, and sizes as specified on the Drawings and in accordance with Manufacturer's instructions. This also includes layout, pre-marking, asphalt surface preparation including milling (< 5 mm), adhesion to pavement, inspection and maintenance during warranty period. The surface of the preformed thermoplastic material shall contain factory applied anti-skid/anti-slip and retro-reflective elements.

.24 Thermoplastic Left/Right Sharrow Turn Box

Unit of Measurement: each (ea.)

This items includes: supply and application of preformed thermoplastic markings in the materials, colors, and sizes as specified on the Drawings and in accordance with Manufacturer's instructions. This also includes layout, pre-marking, asphalt surface preparation including milling (< 5 mm), adhesion to pavement, inspection and maintenance during warranty period. The surface of the preformed thermoplastic material shall contain factory applied antiskid/anti-slip and retro-reflective elements.

.30 Thermoplastic New Intersection Markings

Unit of Measurement: lump sum (l.s.)

This item includes: supply and application of preformed thermoplastic markings in the materials, colors, and sizes as specified on the Drawings and in accordance with Manufacturer's instructions. This also includes layout, pre-marking, asphalt surface preparation including milling (< 5

mm), adhesion to pavement, inspection and maintenance during warranty period. The surface of the preformed thermoplastic material shall contain factory applied anti-skid/anti-slip and retro-reflective elements.

.31 Removal of Existing Thermoplastic Markings

Unit of Measurement: square metre (m²), Each or lump sum (l.s.)

Method of Measurement: Plan Measurement, per item or as Lump Sum

This item includes: the supply and installation of all materials required to remove the thermoplastic pavement markings in the configuration shown on the drawing and as specified by the Engineer.

.32 Replacement of Existing Thermoplastic Markings

Unit of Measurement: lump sum (l.s.)

This item includes: accurate inventory of existing pavement markings and the supply and application of preformed thermoplastic markings in the colours, sizes and configuration as necessary to replace the markings which existed prior to construction. Also includes layout, pre-marking, asphalt surface preparation including milling (< 5 mm), adhesion to pavement, inspection and maintenance during warranty period. The surface of the preformed thermoplastic material shall contain factory applied anti-skid/anti-slip and retro-reflective elements.

65.3 MMA (Methyl Methacrylate) Markings

- .1 MMA (Methyl Methacrylate) Lines
- .2 MMA (Methyl Methacrylate) Stop Bars
- .3 MMA (Methyl Methacrylate) Yield Line
- .4 MMA (Methyl Methacrylate) Crosswalk

Unit of Measurement: metre (m)

Method of Measurement: slope measure

This item includes: supply and application of Ennis-Flint HPS-6 98:2 MMA (Methyl Methacrylate) (or approved equivalent) markings in the materials, colors, and sizes as specified on the Drawings and in accordance with Manufacturer's instructions. This also includes layout, pre-

marking, asphalt surface preparation including sweeping, application to pavement, inspection and maintenance during warranty period.

.5 MMA (Methyl Methacrylate) Zebra Crosswalk

Unit of Measurement: metre (m)

Method of Measurement: slope measure

This item includes: supply and application of Ennis-Flint MMax MMA (Methyl Methacrylate) (or approved equivalent) markings in the materials, colors, and sizes as specified on the Drawings and in accordance with Manufacturer's instructions. This also includes layout, pre-marking, asphalt surface preparation including sweeping, application to pavement, inspection and maintenance during warranty period.

.6 MMA (Methyl Methacrylate) Hatching-White
.7 MMA (Methyl Methacrylate) Hatching-Yellow

Unit of Measurement: square metre (m²)

Method of Measurement: slope measure of surface area including perimeter line.

This item includes: supply and application of Ennis-Flint HPS-6 98:2 MMA (Methyl Methacrylate) (or approved equivalent) markings in the materials, colors, and sizes as specified on the Drawings and in accordance with Manufacturer's instructions. This also includes layout, pre-marking, asphalt surface preparation including sweeping, application to pavement, inspection and maintenance during warranty period.

.8 MMA (Methyl Methacrylate) Intersection Box (Hatched)

Unit of Measurement: square metre (m²)

Method of Measurement: plan measurement

This item includes: supply and application of Ennis-Flint MMax MMA (Methyl Methacrylate) (or approved equivalent) markings in the materials, colors, and sizes as specified on the Drawings and in accordance with Manufacturer's instructions. This also includes layout, pre-marking, asphalt surface preparation including sweeping, application to

pavement, inspection and maintenance during warranty period.

- .9 MMA (Methyl Methacrylate) Arrows
- .1 MMA (Methyl Methacrylate) Arrow $\frac{3}{4}$ TAC size
 - .2 MMA (Methyl Methacrylate) Arrow $\frac{1}{2}$ TAC size
 - .3 MMA (Methyl Methacrylate) Roundabout Arrow

Unit of Measurement: Each

Method of Measurement: number of units installed

This item includes: supply and application of Ennis-Flint HPS-6 98:2 MMA (Methyl Methacrylate) (or approved equivalent) markings in the materials, colors, and sizes as specified on the Drawings and in accordance with Manufacturer's instructions. This also includes layout, pre-marking, asphalt surface preparation including sweeping, application to pavement, inspection and maintenance during warranty period.

- .10 MMA (Methyl Methacrylate) Bicycle Symbols
- .1 MMA (Methyl Methacrylate) Bicycle Symbol 1.2m x 2.1m, White on Black Background
 - .2 MMA (Methyl Methacrylate) Bicycle Symbol 1.2m x 2.1m, White on Green Background
 - .3 MMA (Methyl Methacrylate) Bicycle Symbol 0.6m x 1.2m, White on Green Background

Unit of Measurement: Each

Method of Measurement: number of units installed

This item includes: supply and application of Ennis-Flint HPS-6 98:2 MMA (Methyl Methacrylate) (or approved equivalent) markings in the materials, colors, and sizes as specified on the Drawings and in accordance with Manufacturer's instructions. This also includes layout, pre-marking, asphalt surface preparation including sweeping, application to pavement, inspection and maintenance during warranty period.

- .11 MMA (Methyl Methacrylate) Advance Yield to Pedestrian Line

Unit of Measurement: metre (m)

Method of Measurement: slope measure

This item includes: supply and application of Ennis-Flint HPS-6 98:2 MMA (Methyl Methacrylate) (or approved equivalent) markings in the materials, colors, and sizes as specified on the Drawings and in accordance with Manufacturer's instructions. This also includes layout, pre-marking, asphalt surface preparation including sweeping, application to pavement, inspection and maintenance during warranty period.

.12 MMA (Methyl Methacrylate) Speed Hump/Table Markings

Unit of Measurement: Per speed hump/table location

Method of Measurement: number of speed humps/tables installed.

This item includes: supply and application of Ennis-Flint HPS-6 98:2 MMA (Methyl Methacrylate) (or approved equivalent) markings in the materials, colors, and sizes as specified on the Drawings and in accordance with Manufacturer's instructions. This also includes layout, pre-marking, asphalt surface preparation including sweeping, application to pavement, inspection and maintenance during warranty period.

.13 MMA (Methyl Methacrylate) Reserved Lane Diamond Symbol, White on Black Background

.14 Thermoplastic Reserved Lane Diamond Symbol, White on Red Background

.15 Thermoplastic Shared Use Lane Symbol 1.0m x 3.1m

.1 Thermoplastic Shared Use Lane Symbol, White on Black Background

.2 Thermoplastic Shared Use Lane Symbol, White on Green Background

Unit of Measurement: Each

This item includes: supply and application of Ennis-Flint HPS-6 98:2 MMA (Methyl Methacrylate) (or approved equivalent) markings in the materials, colors, and sizes as specified on the Drawings and in accordance with Manufacturer's instructions. This also includes layout, pre-marking, asphalt surface preparation including sweeping, application to pavement, inspection and maintenance during warranty period.

- .16 MMA (Methyl Methacrylate) Shark Teeth 450mm x 150mm, 5 per row

Unit of Measurement: Row

Method of Measurement: number of rows installed

This item includes: supply and application of Ennis-Flint HPS-6 98:2 MMA (Methyl Methacrylate) (or approved equivalent) markings in the materials, colors, and sizes as specified on the Drawings and in accordance with Manufacturer's instructions. This also includes layout, pre-marking, asphalt surface preparation including sweeping, application to pavement, inspection and maintenance during warranty period.

- .17 MMA (Methyl Methacrylate) Two Stage Left Turn Waiting Box, 2m x 3m, White on Green Background

Unit of Measurement: Each

This item includes: supply and application of Ennis-Flint HPS-6 98:2 MMA (Methyl Methacrylate) (or approved equivalent) markings in the materials, colors, and sizes as specified on the Drawings and in accordance with Manufacturer's instructions. This also includes layout, pre-marking, asphalt surface preparation including sweeping, application to pavement, inspection and maintenance during warranty period.

- .18 MMA (Methyl Methacrylate) Vehicle/Bike Zebra Conflict Marking, 1.8m x 0.6m total (1.5m green with 0.15m white ea. End)

- .19 MMA (Methyl Methacrylate) Driveway/Bike Zebra Conflict Marking, 1.3m x 0.6m total (1.0m green with 0.15m white ea. End)

- .20 MMA (Methyl Methacrylate) Bike/Pedestrian Zebra Conflict Marking, 2.5m long x 1.5m wide, 0.3m white, 0.3m space

Unit of Measurement: metre (m)

Method of Measurement: slope measurement

This item includes: supply and application of Ennis-Flint MMax MMA (Methyl Methacrylate) (or approved equivalent) markings in the materials, colors, and sizes as specified on the Drawings and in accordance with Manufacturer's instructions. This also includes layout, pre-marking, asphalt surface preparation including sweeping, application to

pavement, inspection and maintenance during warranty period.

.21 MMA (Methyl Methacrylate) Trail Crosswalk Markings

Unit of Measurement: metre (m)

Method of Measurement: slope measurement

This item includes: supply and application of Ennis-Flint HPS-6 98:2 MMA (Methyl Methacrylate) (or approved equivalent) markings in the materials, colors, and sizes as specified on the Drawings and in accordance with Manufacturer's instructions. This also includes layout, pre-marking, asphalt surface preparation including sweeping, application to pavement, inspection and maintenance during warranty period.

.22 MMA (Methyl Methacrylate) Modified Two Stage Left Turn Bike Box, 1.8m x 2.6m, White on Green Background

Unit of Measurement: each (ea.)

This item includes: supply and application of Ennis-Flint MMax MMA (Methyl Methacrylate) (or approved equivalent) markings in the materials, colors, and sizes as specified on the Drawings and in accordance with Manufacturer's instructions. This also includes layout, pre-marking, asphalt surface preparation including sweeping, application to pavement, inspection and maintenance during warranty period.

.23 MMA (Methyl Methacrylate) White Single Line 300 mm wide, 3 m Spacing

Unit of Measurement: metre (m)

Method of Measurement: slope measure

This item includes: supply and application of Ennis-Flint HPS-6 98:2 MMA (Methyl Methacrylate) (or approved equivalent) markings in the materials, colors, and sizes as specified on the Drawings and in accordance with Manufacturer's instructions. This also includes layout, pre-marking, asphalt surface preparation including sweeping, application to pavement, inspection and maintenance during warranty period.

.24 MMA (Methyl Methacrylate) Left/Right Sharrow Turn Box

Unit of Measurement: each (ea.)

This item includes: supply and application of Ennis-Flint MMax MMA (Methyl Methacrylate) (or approved equivalent) markings in the materials, colors, and sizes as specified on the Drawings and in accordance with Manufacturer's instructions. This also includes layout, pre-marking, asphalt surface preparation including sweeping, application to pavement, inspection and maintenance during warranty period.

.30 MMA (Methyl Methacrylate) New Intersection Markings

Unit of Measurement: lump sum (l.s.)

This item includes: supply and application of MMA (Methyl Methacrylate) markings in the materials, colors, specifications, and sizes as specified on the Drawings and in accordance with Manufacturer's instructions. This also includes layout, pre-marking, asphalt surface preparation including sweeping, application to pavement, inspection and maintenance during warranty period.

.31 Removal of Existing MMA (Methyl Methacrylate) Markings

Unit of Measurement: square metre (m²), Each or lump sum (l.s.)

Method of Measurement: Plan Measurement, per item or as Lump Sum

This item includes: the supply and installation of all materials required to remove the MMA (Methyl Methacrylate) pavement markings in the configuration shown on the drawing and as specified by the Engineer.

.32 Replacement of Existing MMA (Methyl Methacrylate) Markings

Unit of Measurement: lump sum (l.s.)

This item includes: accurate inventory of existing pavement markings and the supply and application of preformed MMA (Methyl Methacrylate) markings in the colours, sizes, specifications, and configuration as necessary to replace the markings which existed prior to construction. Also includes layout, pre-marking, asphalt surface preparation

including sweeping, application to pavement, inspection and maintenance during warranty period.

66. Preblast Survey

Unit of Measurement: lump sum (l.s.)

This item includes: all costs associated with conducting a preblast survey as described in HRM Bylaw B-600 Respecting Blasting. The preblast survey shall meet all requirements as described in Section 31 20 00 Earthwork.

67. Preblast Trenches

Unit of Measurement: cubic metre (m³)

This item includes for all costs associated with drilling and blasting rock in trenches for future excavation operations. This item also includes all costs for services of the blasting consultant.

68. Trench Plugs

Unit of Measurement: Lump Sum (L.S.) or Each

This item includes: supply and placement of material for trench plugs as detailed in locations indicated on plan or as directed by Engineer.

69. Traffic Calming

1. Speed Hump

Unit of Measurement: Each

This item includes: supply and installation of asphalt speed hump as per Standard Detail HRM 31. Cross sections of each and every speed hump are to be surveyed per Standard Detail HRM 136 to verify that speed hump has been constructed as intended and falls within required tolerance range. Contractor to provide survey information within two (2) weeks of construction to the Engineer for review. Speed hump will be acceptable only if it forms a shape relative to the design curve within the tolerance limits. Contractor shall be responsible to take steps necessary to correct any deficiencies that fall outside of required tolerance range.

.2 Speed Table

Unit of Measurement: Each

This item includes: supply and installation of asphalt speed table as per Standard Detail HRM 143. Cross sections of each and every speed table are to be surveyed per Standard Detail HRM 144 to verify that speed table has been constructed as intended and falls within required tolerance range. Contractor to provide survey information within two (2) weeks of construction to the Engineer for review. Speed table will be acceptable only if it forms a shape relative to the design curve within the tolerance limits. Contractor shall be responsible to take steps necessary to correct any deficiencies that fall outside of required tolerance range.

.3 Raised Crosswalk

Unit of Measurement: Each

This item includes: supply and installation of raised crosswalk as per the Tender Drawings. Cross sections of every constructed raised crosswalk are to be surveyed per Standard Detail HRM 144 to verify that raised crosswalk has been constructed as intended and falls within required tolerance range. Contractor to provide survey information to the Engineer for review. Raised crosswalk will be acceptable only if it forms a shape relative to the design curve within the tolerance limits. Contractor shall be responsible to take steps necessary to correct any deficiencies that fall outside of required tolerance range.

.4 Speed Cushion

Unit of Measurement: Each

This item includes: supply and installation of asphalt speed cushion as per the Tender Drawings. Survey points of every constructed speed cushion are to be gathered per Tender Drawings to verify that the speed cushion has been constructed as intended and falls within required tolerance range. Contractor to provide survey information to the Engineer for review. Speed cushion will be acceptable only if it forms a shape relative to the design shape, within a tolerance of ± 5 mm. Contractor shall be responsible to take steps necessary to correct any deficiencies that fall outside of required tolerance range.

EROSION AND
SEDIMENT
CONTROL70. Erosion and Sediment Control Plan

Unit of Measurement: Lump Sum

This item includes the preparation of an erosion and sediment control plan in accordance with NSE requirements to be provided to the Engineer and submitted to Nova Scotia Environment one week following award. This plan shall be signed and stamped by a Professional Engineer licenced to practice in Nova Scotia. The contractor's representative shall be trained in erosion sediment & control practices.

71. Sediment Controls.1 Silt Fence

Unit of Measurement: metre (m).

Method of Measurement: slope measure.

This item includes: supply, installation, maintenance and removal including stakes and fabric and reinstatement of area.

.2 Turbidity Curtain

Unit of Measurement: Each

This item includes: the supply, installation, maintenance and subsequent removal of the turbidity curtain. Top of boom must be marked with Contractor's company name and contact number in indelible and waterproof paint. Also includes all other costs incidental to this item.

.3 Flow Checks

Unit of Measurement: Each

This item includes: supply, installation, maintenance and removal.

.4 Soaker Bags

Unit of Measurement: Each

This item includes: supply, installation, maintenance and removal.

.5 Straw Bales

Unit of Measurement: Each

This item includes: supply, placement, maintenance and removal of straw bales in locations as directed by Engineer.

72. Ground Covers

Unit of Measurement: tonne (t) or square metre (m²).

Method of Measurement: scale tickets signed by Engineer or slope measure of indicated area at specified mean depth or thickness specified on the drawings..

.1 Straw or Hay Cover

.2 Gravel Cover

This item includes: supply, installation to thickness specified on drawings and maintenance.

.3 Rip Rap and Armour Stone Protection

This item includes: common excavation, supply and placement of geotextile and rock as specified, and reinstatement as required.

.4 Environmental Mat

Unit of Measurement: square metre (m²)

Method of Measurement: slope measure

This item includes: supply, installation and maintenance as specified.

73. Flow Diversions

Flow diversions shall be sized to handle the flow resulting from at minimum a 1:2 year rainfall event.

.1 Diversion Ditches

Unit of Measurement: metre (m).

Method of Measurement: slope measure of indicated width.

This item includes: laying out grades and lines, excavation and lining as required, maintenance, removal and reinstatement.

.2 Flow Diversion

Unit of Measurement: Each

This item includes: clearing, grubbing, and excavation for the supply, installation, maintenance, diversion channels and/or pumping and subsequent removal of barriers. Also includes all reinstatement and all other costs incidental to this item.

.3 Settlement Pond

Unit of Measurement: Each

This item includes: clearing, grubbing, excavation necessary for the installation, maintenance and subsequent removal of all settlement ponds required for project, reinstatement and all other costs incidental to this item. This item also includes fencing, as specified, to surround the pond.

ELECTRICAL

80. Direct Buried Conduit

Unit of Measurement: metre (m)

Method of Measurement: lineal metre (m) of direct buried conduit

This item includes: common excavation, backfilling, gravel reinstatement, bedding, compaction, jointing, electrical fluorescent tape, lumber, stub-ups (including the concrete pole riser where indicated), pole terminations, conduit, junction boxes, pull pits, provision of temporary service as required, connections to existing, ground wire if required, etc. necessary to complete the work.

This item does not include reinstatement of asphalt concrete, concrete sidewalk, concrete curb and gutter and topsoil and sod, which is to be paid for under separate pay items.

81. Traffic Concrete Base

Unit of Measurement: Each

This item includes: common excavation, backfill, reinforcing steel, concrete, formwork, rebar, anchor bolts, internal conduit to 450 mm outside base and connections to conduit runs, etc.

81.16 Removal of Abandoned Traffic Signal Bases

Unit of Measurement: Each (ea.)

This item includes: mass excavation and embankment, common excavation, removal and disposal of abandoned concrete bases, backfill, and reinstatement as specified.

81.17 Removal of Abandoned Street Light Signal Bases

Unit of Measurement: Each (ea.)

This item includes: mass excavation and embankment, common excavation, removal and disposal of abandoned concrete bases, backfill, and reinstatement as specified. This item does not include reinstatement of concrete sidewalk, concrete curb and gutter, topsoil and sod, which shall be paid for under separate pay items.

81.18 Install RRFB Post and Base

Unit of Measurement: Each (ea.)

This item includes: common excavation, backfill, supply and installation of concrete, reinforcing steel, iron pipe sleeve, and post as per Standard Details HRM 172 and 180.

This item does not include the supply and installation of RRFB equipment.

82. Overhead Wiring for Detector Loops

Unit of Measurement: metre (m)

Method of Measurement: lineal metre (m) of overhead wiring between indicated locations

This item includes: the supply of messenger and traffic signal cable, and installation in accordance with Standard Details HRM 82 and HRM 83.

This item does not include the installation of the detector loops which is paid separately.

83. Detectors

Unit of Measurement: lump sum (l.s.) or Each

This item includes: the supply and installation of detectors as specified, any required junction boxes and any required home run to the controller.

84. RA-5 Crosswalk Lights

Unit of Measurement: lump sum (l.s.)

This item includes: the supply and installation of all RA-5 crosswalk lights, poles, mast arms, installation of PXO controller(s) where required and any other necessary appurtenances. This item also includes the pulling of all wires, all connections, grounding, final wiring, testing, demonstration, and commissioning including CSA certification. This item also includes the removal of all traffic signal equipment not to be re-used plus delivery to the HRM MacKintosh Street depot. The Contractor shall schedule and supply the traffic control for overhead electrical inspections by the Engineer at the completion of the work.

85. Traffic Signal Installation.1 Materials

Unit of Measurement: lump sum (l.s.)

This item includes the supply of all required traffic signal equipment required for a fully functional system including all traffic signal heads, pedestrian APS push buttons and cable, overhead wiring, LED countdown pedestrian digital modules, GPS Opticom, arm brackets, UPS Battery Backup as indicated, and all incidentals and associated hardware and wiring, etc. required to complete the work.

This item does not include the supply of traffic signal poles, combination signal street light poles, transformer bases, truss arms, traffic signal cable and signal controller, which will be supplied to the contractor by HRM, unless indicated otherwise on the drawings.

.2 Labour

Unit of Measurement: lump sum

This item includes: installation of all required traffic signal equipment; poles, mast arms, signals, push buttons, GPS Opticom, UPS Battery Backup as indicated, davit arms, pulling of wires, wires, all connections, grounding, final wiring including overhead, testing, demonstration and commissioning including CSA certification not included under Item No. 85.1. Anti-seize compound to be applied to all screws in weather exposed equipment. This item also includes the installation of the controller on the concrete base and the removal of all traffic signal equipment not to

be re-used plus delivery to the HRM MacKintosh Street depot. The Contractor shall schedule and supply the traffic control for overhead electrical inspections by the Engineer at the completion of the work.

86. Ornamental Street Light

Unit of Measurement: Each

This item includes: the supply and installation or relocation of the ornamental street light as shown on the drawings. This item also includes the pulling of wires, all connections, grounding, final wiring including overhead, testing, demonstration, and commissioning.

87. Area Lighting

Unit of Measurement: Each

This item includes: the supply and installation of the area lighting as shown on the drawings. This item also includes the pulling of wires, all connections, grounding, final wiring including overhead, testing, demonstration, and commissioning.

87.3 Install Street Light on Utility Pole

Unit of Measurement: each (ea.)

This item includes: the supply and installation of street light fixtures, Acuity Photocell (Itron ready), and davit arms on existing utility poles as shown on the drawings. This item also includes wiring, connections, coordination and approvals with NS Power, inspection and permitting as required, testing, and commissioning.

88. Junction Box Removal

Unit of Measurement: Each

This item includes: locating, removal and disposal of existing junction boxes as indicated.

MISCELLANEOUS 90. Project Information Sign

Unit of Measurement: Each

This item includes: connection to an existing post, maintenance and subsequent removal of the Project Information sign thirty (30) days after Total Performance of the Work. Sign will be supplied by HRM.

92. Guiderails

92.1 Galvanized Steel W-Beam Guiderail (Weak Post)

Unit of Measurement: Metre (m)

Method of Measurement: slope measure.

This item includes: mass excavation – common, backfill and compaction, supply and installation of galvanized steel weak-post W-beam guiderail including posts, rail, reflectors and accessories as per standard drawing HRM36, NSTIR drawings HS518 and HS519 and the Tender Drawings. This item also includes the removal and disposal of existing guiderail and posts and supply of documentation regarding the disposal of creosote posts at an approved construction and demolition waste facility, if applicable.

92.2 Galvanized Steel W-Beam Guiderail (Strong Post)

Unit of Measurement: Metre (m)

Method of Measurement: slope measure.

This item includes: mass excavation – common, backfill and compaction, supply and installation of galvanized steel strong-post W-beam guiderail including posts, rail, reflectors and accessories as per standard drawing HRM36, NSTIR drawings HS518 and HS519 and the Tender Drawings. This item also includes the removal and disposal of existing guiderail and posts and supply of documentation regarding the disposal of creosote posts at an approved construction and demolition waste facility, if applicable.

92.3 Guiderail Protection of Highway Sign Truss Structures

Unit of Measurement: Metre (m)

Method of Measurement: slope measure.

This item includes: mass excavation – common, backfill and compaction, supply and installation of galvanized steel W-beam guiderail protection of highway truss structures including posts, rail, reflectors, and accessories as per standard drawing HRM36, NSTIR drawings HS518, HS519, HS526 and HS527, and the Tender Drawings. This item also includes the removal and disposal of existing guiderail and posts and supply of documentation regarding the

disposal of creosote posts at an approved construction and demolition waste facility, if applicable.

92.4 Treated Wood Guiderail

Unit of Measurement: Metre (m)

Method of Measurement: slope measure.

This item includes: mass excavation – common, backfill and compaction, supply and installation of treated wood guiderail including timber posts, rail, reflectors and accessories as per the Tender Drawings. This item also includes the removal and disposal of existing guiderail and posts and supply of documentation regarding the disposal of creosote posts at an approved construction and demolition waste facility.

92.5 Galvanized Steel W-beam Guiderail (steel post)

Unit of Measurement: Metre (m)

Method of Measurement: slope measure.

This item includes: mass excavation – common, backfill and compaction, supply and installation of galvanized steel W-beam guiderail including steel posts, w-beam, reflectors, and accessories as shown on the Tender Drawings. Steel posts to be W15x14 (metric) or W6x8.5 (imperial). This item also includes the removal and disposal of existing guiderail and posts and supply of documentation regarding the disposal of creosote posts at an approved construction and demolition waste facility.

All W-beam, spacing, reflectors, accessories, and other details as per HRM detail 36.

92.6 Remove Guiderail

Unit of Measurement: Metre (m)

Method of Measurement: slope measure.

This item includes: mass excavation – common, backfill and compaction, removal and disposal of existing guiderail and posts as per the Tender Drawings, the supply of documentation regarding the disposal of creosote posts at an approved construction and demolition waste facility, if applicable. This item also includes surface reinstatement.

94.1 Tactile Walking Surface Indicator Plates

Unit of Measurement: Each (ea)

This item includes: supply and installation of Tactile Walking Surface Indicators as per manufacturer's instructions and reinstatement as per Tender Drawings and specifications. This item also includes any TWSI wedges or incidentals as required.

94.2 Directional Tiles

Unit of Measurement: square metre (m2)

Method of Measurement: slope measure

This item includes: mass excavation and embankment – common, sub-grade preparation, 150 mm Type 1 granular base, 100 mm cast-in-place concrete base, supply and placement of directional paver tiles in accordance with the Tender drawings, bedding and polymeric jointing sand, and supply and placement of backfill as indicated.

95. Pavement Marking Drawing

.1 Scaled and Surveyed Pavement Marking Drawing

Unit of Measurement: Each

This item includes: the supply of a paper hard copy and an electronic pavement marking drawing that is to scale and from a survey for each street that is identified to require a scaled and surveyed drawing in this contract document, or on any drawing included with this contract document, or both. Each drawing shall be as specified in section 3.2, Pavement Marking Drawings, of Section S-4, Pavement Markings, of this contract document, for all locations that require a scaled and surveyed drawing.

.2 Non-scaled Pavement Marking Drawing

Unit of Measurement: Each

This item includes: the supply of a paper hard copy and an electronic pavement marking drawing not to scale for each street that is identified to require a non-scaled drawing in this contract document, or on any drawing included with this contract document, or both. Each drawing shall be as specified in section 3.2, Pavement Marking Drawings, of

Section S-4, Pavement Markings, of this contract document, for all locations that require a non-scaled drawing.

.3 Pavement Marking Description

Unit of Measurement: Each

This item includes: a pavement marking description for each street that is identified to require a pavement marking description in this contract document, or on any drawing included with this contract document, or both. Each description shall be as specified in section 3.2, Pavement Marking Drawings, of Section S-4, Pavement Markings, of this contract document, for all locations that require a pavement marking description.

96. Daylighting Underground Utilities

.1 Exploratory Digging

Unit of Measurement: Each

This item includes exploratory digging by machine at the direction of the Engineer. This may be done to determine the nature of the soil, to see if there is rock present, to confirm that there is no infrastructure present, or for other reasons at the discretion of the Engineer. This item includes all labour, equipment and materials required to do the work. This work also includes disposal of excess material and reinstatement as required.

.2 Daylighting Underground Utilities

Unit of Measurement: Each

This item includes daylighting underground utilities by hand digging or hydro excavation to identify and locate underground infrastructure. This item includes all labour, equipment and materials required to do the work. This work also includes disposal of excess material and reinstatement as required.

98. Surveyed Planing Layout

Unit of Measurement: Each

This item includes: material and labor required to survey existing road centerline and edge of pavement every 15 m for complete roadway. This item also includes confirming existing road cross

slopes and recording changes in cross slope when greater than 0.5% when planing. Contractor shall show markings along the road to indicate cut or fill from edge of pavement, equal to the width of the planer used to plane the road. Confirm limits of survey planing with HRM Representative prior to construction.

99. Hydro Excavation Services

Unit of Measurement: Lump Sum (LS)

This item includes: all labour and equipment to carry out hydro excavation activities where shown on the Project Drawings, including locates for all utilities in the area, all required permits and fees, coordination with the engineer and access for HRM surveyors to confirm location of exposed pipelines, and reinstatement including backfilling of gravels and replacement of asphalt after hydro-excavation is complete. All work to be completed in accordance with all safety requirements including safe work around gas mains.

100. Traffic Control

Unit of Measurement: Lump Sum (LS)

This item includes: all costs for providing labour, material, equipment, and personnel to accommodate adequate vehicular, transit, active transportation, and pedestrian traffic control as stipulated in the HRM Traffic Control Manual Supplement (latest edition), Administrative Order No. 2018-005-ADM – Respecting Construction Site Management, Contract Specifications and drawings.

This item also includes all safety measures required to complete the work including fencing to protect the public from entering the construction site where required and maintaining existing access for vehicles and pedestrians as required.

102. Streetscaping

.1 Bike Rack

Unit of Measurement: Each (Ea.)

This item includes: all labour and materials required for the installation of a post and ring bike rack as per HRM Standard Detail HRM 167, including and concrete base as specified and as shown on the tender drawings and standard detail.

This item also Includes excavation and embankment – common, sub-grade preparation, 150 mm Type 1 granular base (extended 150 mm beyond edge of concrete structure), concrete slab, anchor bolts, and backfill as required.

Confirm post and ring bike rack location with HRM Representative prior to installation.

.2 Backless Transit Bench

Unit of Measurement: Each (Ea.)

This item includes: the supply and installation of a black metal decorative bench and footings in accordance with the HRM Municipal Design Guidelines, Part A, Section 3.3.2. The bench shall be black powder coated, solid cast aluminum ends, seats to be flat bars and H.S. steel tubes or aluminum tubes, fully welded and assembled on delivery.

The bench shall be between 430 mm and 485 mm from final grade (level ground surface). Any bench to be placed on slopes shall be shimmed to provide a level seating surface and bolted either directly to concrete or to concrete below unit pavers.

The Contractor may select from products listed below (or approved equivalent)

- Maglin MLB300B-M
- Maglin MLB300-MH
- Canaan Metal Backless Park Bench CAL-953B
- Canaan Metal Backless Park Bench CAL-=957B
- DuMor Model 446-60
- DuMor Model 446-60q01
- DuMor Model 282-60

Confirm backless bench type, location and positioning onsite with HRM Representative prior to installation.

.3 Flexible Delineator

.1 Supply and Install Flexible Delineator

Unit of Measurement: Each

This item includes: supply and installation of flexible delineators and associated hardware, preparation of the surface on which the delineators are to be placed so they are free from all loose and foreign material, and installation

of flexible delineators as detailed in the drawings and as per manufacturers instruction.

.2 Install Flexible Delineator

Unit of Measurement: each (ea.)

This item includes: delivery of delineators from HRM MacKintosh Depot to the project site, preparation of the surface on which the flexible delineator is to be placed so that it is dry and free from all loose and foreign material, installation of flexible delineators as per manufacturer's instructions including the supply of all required fasteners and associated hardware, survey layout, and delivery of all unused, removed, or surplus flexible delineators to the HRM MacKintosh Depot. Delineators to be supplied by HRM.

103 Temporary Utility Pole Support

Unit of Measurement: each (ea.)

This item includes: Provision and maintenance of temporary support for existing utility pole as shown on drawings. This also includes all coordination and permitting with Nova Scotia Power and utilities as required and supply of stamped engineering drawings, as required. This item also includes removal of shoring at the conclusion of the work.

****** END OF SECTION 01 22 00 ******

PART 1 – GENERAL

- 1.1 Work Included
- 1.2 Related Sections
- 1.3 Reference Standards

PART 2 – EXECUTION

- 2.1 Fine Grading
- 2.2 Adjusting Tops of Castings
- 2.3 Water Main Leakage Testing
- 2.4 Pavement Markings
- 2.5 Quality Management Plan – Cold Weather

PART 3 – MATERIALS

- 3.1 General
- 3.2 Aggregates
 - .1 Fine Aggregates
 - .2 Coarse Aggregates
 - .3 Gradation of Combined Aggregate
 - .4 Mineral Filler
 - .5 Performance Graded Asphalt Binder (PGAB)
 - .6 Reclaimed Asphalt Pavement (RAP)
 - .7 Tack Coat

PART 4 – MIX DESIGN REQUIREMENTS

- 4.1 Field Mix Tolerance
- 4.2 Anti-Stripping Agents

PART 5 – TRANSPORTATION, PLACEMENT AND CONSTRUCTION

- 5.1 Transportation of Hot Mix Asphalt
- 5.2 Placing of Hot Mix Asphalt
- 5.3 Thickness Requirements
 - .1 Dispute Resolution
 - .2 Appeal Testing Process
 - .3 Cost of Appeal Testing
- 5.4 Placement by Hand
- 5.5 Compaction
 - .1 Compaction Requirements
 - .2 Analysis of Rejected Asphalt Concrete Mix
 - .3 Dispute Resolution
 - .4 Appeal Testing Process
 - .5 Cost of Appeal Testing
- 5.6 Joints
 - .1 Transverse Joints
 - .2 Keyed Joints
 - .3 Longitudinal Joints

PART 6 – QUALITY CONTROL / QUALITY ASSURANCE

- 6.1 General
- 6.2 Quality of Asphaltic Concrete Paving Mixture
- 6.3 Quality of Asphaltic Concrete Compacted Pavement

PART 7 – PRICE ESCALATION / DE-ESCALATION - PERFORMANCE GRADED ASPHALT BINDER (PGAB)PART 8 – WARM MIX ASPHALT

- 8.1 General

PART 9 – WARRANTY

- 9.1 General

PART 1 - GENERAL

This specification covers the preparation of hot-mixed and hot laid asphalt concrete utilised during HRM construction, HRM maintenance activities and development projects relating to pavement works.

The hot mix asphalt concrete shall comprise a mixture of mineral aggregate, filler and asphaltic binder combined and placed in accordance with this specification.

This standard does not address any safety concerns related to the use of its contents. It is the responsibility of the user of this specification to establish appropriate safe work practices applicable to the work detailed within.

Conversion of in-place pay volume (pay area time thickness) to unit tonnage for asphalt shall be at the rate of 2.3 tonnes per cubic metre.

1.1 Work Included

This section specifies requirements for constructing asphalt concrete pavement. Work includes fine grading, supply and placing of tack coat, hot mix asphalt concrete, and pavement markings.

1.2 Related Sections

| | | |
|----|---|------------------|
| .1 | Concrete | Section 03 30 00 |
| .2 | Earthwork | Section 31 20 00 |
| .3 | Walks, Curbs and Gutters | Section 32 16 00 |
| .4 | Reinstatement | Section 32 98 00 |
| .5 | Precast Manholes, Catch-Basins and Structures | Section 33 39 00 |
| .6 | Standard Details | Section 39 00 00 |
| .7 | Specification for Performance Graded Asphalt Binder | S-2 |
| .8 | Pavement Markings | S-4 |

1.3 Reference Standards

| | |
|----|---|
| .1 | Canadian General Standards Board (CGSB) 1-GP-74M Paint, Traffic, Alkyd |
| .2 | Nova Scotia Transportation and Infrastructure Renewal Standard Specification - Highway Construction and Maintenance |
| .3 | Transportation Association of Canada; Manual of Uniform Traffic Control Devices for Canada |
| .4 | AASHTO T 283, Standard Method of Test for Resistance of Compacted Asphalt Mixtures to Moisture-Induced Damage |
| .5 | AASHTO T 304(A), Standard Method of Test for Uncompacted Void Content of Fine Aggregate |

- .6 ASTM C 88, Standard Test Method for Soundness of Aggregates by Use of Sodium Sulfate or Magnesium Sulfate
- .7 ASTM C 117, Standard Test Method for Materials Finer than 75- μ m (No. 200) Sieve in Mineral Aggregates by Washing
- .8 ASTM C 127, Standard Test Method for Relative Density (Specific Gravity) and Absorption of Coarse Aggregate
- .9 ASTM C 128, Standard Test Method for Relative Density (Specific Gravity) and Absorption of Fine Aggregate
- .10 ASTM C 131, Standard Test Method for Resistance to Degradation of Small-Size Coarse Aggregate by Abrasion and Impact in the Los Angeles Machine
- .11 ASTM C 136, Standard Test Method for Sieve Analysis of Fine and Coarse Aggregates
- .12 ASTM D 242, Standard Specification for Mineral Filler for Bituminous Paving Mixtures
- .13 ASTM D 546, Standard Test Method for Sieve Analysis of Mineral Filler for Asphalt Paving Mixtures
- .14 ASTM D 2041, Standard Test Method for Theoretical Maximum Specific Gravity and Density of Bituminous Paving Mixtures
- .15 ASTM D 2419, Standard Test Method for Sand Equivalent Value of Soils and Fine Aggregate
- .16 ASTM D 3203, Standard Test Method for Percent Air Voids in Compacted Asphalt Mixtures
- .17 ASTM D 4791, Standard Test Method for Flat Particles, Elongated Particles, or Flat and Elongated Particles in Coarse Aggregate
- .18 ASTM D 6927, Standard Test Method for Marshall Stability and Flow of Asphalt Mixtures
- .19 ASTM D 6928, Standard Test Method for Resistance of Coarse Aggregate to Degradation by Abrasion in the Micro-Deval Apparatus
- .20 ASTM D 7428-15, Standard Test Method for Resistance of Fine Aggregate to Degradation by Abrasion in the Micro-Deval Apparatus

PART 2 - EXECUTION

2.1 Fine Grading

- .1 Fine grade gravel surface to within 10 mm of elevations and cross sections indicated immediately prior to placement of asphalt materials. Add or remove gravel as required. Compact to 100% Standard Proctor Density or as directed by the Engineer.

2.2 Adjusting Tops of Castings

Prior to placing asphalt surface course:

- .1 Install catchment devices in all manholes prior to work commencing on the manhole. Such catchment devices shall be constructed and installed in a manner so as not to impede the flows through the manhole.
- .2 Adjust manhole covers and catch basin frames to match asphalt surface, using manufactured grade rings or cast in place concrete.
- .3 For streets where full depth asphalt removal is not occurring (i.e. mill and repave) the adjustment area of the manhole is to be filled with temporary hot/cold mix asphalt so that after milling a minimum of 40 mm of asphalt will remain.
- .4 Manhole frame to be installed (reset) after base asphalt has been placed and just before finish asphalt layer is placed unless otherwise approved by Engineer. Note: after setting Utility or other fixed (non-adjustable) manholes, the vertical edges of the structure need to be clearly marked with caution paint.
- .5 Adjust valve boxes to finished asphalt surface. Raise or lower top sections of the valve boxes.
- .6 Upon manhole adjustment, removal of catchment device and all works associated with restoration around the manhole, the contractor shall provide all testing equipment, labour, incidentals, traffic control, etc. required to undertake an inspection of the system to verify its cleanliness. This inspection must be done in the presence of the Engineer.

2.3 Water Main Leakage prior Testing

- .1 After placement of the asphaltic concrete base course and to the placement of the asphaltic concrete surface course, contractor to provide 24 hours notice to Halifax Water for leakage testing. Allow access to and coordinate with Halifax Water for leakage testing.

- 2.4 Pavement Markings .1 Arterials shall have the pre-markings (tabs on milled surface, temporary tape on micro and pavement) applied immediately after the placement of each lift of asphaltic concrete and permanent markings shall be applied within 48 hours. All other streets shall have the permanent markings applied within one week after the placement of the final lift of asphaltic concrete.
- .2 Surface to be dry and clean prior to the application of pavement markings. Apply paint at application rate indicated with spray gun to lines and at locations indicated. Dimensions and colour to HRM's Pavement Markings, Section S-4 specification.
- 2.5 Quality Management Plan – Cold Weather .1 The cut-off date for asphalt construction is October 31. Beyond these dates the proposed asphalt work shall be reviewed on a case-by-case situation and must be approved by HRM. If approved by HRM the QMP shall be adhered to. The length of time beyond the traditional cut-off dates the QMP can be considered will be at the discretion of the Engineer. HRM reserves the right to terminate the QMP program at any point in time. A Professional Engineer in good standing with Engineers Nova Scotia shall certify to HRM that the asphalt work meets the requirements under the QMP and HRM Specifications.
- .2 Prior to the placement of any hot mix asphalt a geotechnical engineering consultant shall test and confirm that the minimum compaction requirements have been achieved in the granular base material. Where the minimum specified compaction is not achieved prior to the granular base material freezing, the contractor shall remove the frozen granular material and underlying soils and shall replace it with non-frozen material. All compaction results shall meet the minimum requirements as described in the HRM standard specifications. HRM may independently perform compaction tests for both the granular and asphalt layers to verify the results. A Professional Engineer in good standing with Engineers Nova Scotia shall certify to HRM that the granular base layers meet the requirements under the QMP and HRM Specifications.
- .3 Asphalt concrete shall not be placed during rain or snow or on asphalt surfaces, which are wet and/or unclean. Asphalt concrete shall not be placed on any surface, which has ponded water. Placing of conventional hot mix asphalt concrete shall not be permitted when the ambient air temperature is below 5 degrees Celsius. The wind chill temperature (if any) must also be included in the final decision. If paving operations are to take place between 0 - 5 degrees Celsius, the contractor shall use a Warm Mix Asphalt Technology in place of conventional Hot Mix

Asphalt, and the contractor shall advise of the technology and receive approval from HRM prior to construction. However, all paving operations shall cease when the ambient air temperature is below 0 degrees Celsius. A joint heater or echelon paving shall be used in cold weather paving. As well, the asphalt temperature testing frequency at the job site shall be increased to ensure the asphalt meets the HRM Specification. A Professional Engineer in good standing with Engineers Nova Scotia shall certify to HRM that the asphalt work meets the requirements under the QMP and HRM Specifications.

- .4 Regardless of the technology used, the contractor shall obtain the minimum compaction requirements as outlined in the HRM specifications. The testing results for the granulars and the asphalt shall be submitted to HRM, and the testing frequency and requirements shall adhere to HRM Specifications. The contractor shall also ensure that all employees are trained and made aware of the importance of quality workmanship.
- .5 The contractor shall implement a Quality Paving Plan to ensure the quantity and quality of equipment and personnel are adequate to achieve a quality end product as outlined in the specifications. There will be a point in time where all concrete and paving operations will cease altogether for the remainder of the year, and the QMP will not be permitted. A notice will be provided at that time. Under these circumstances, temporary asphalt shall be required as per the HRM Specifications.

PART 3 - MATERIALS

3.1 General

The Contractor shall be responsible for the supply, storage and handling of all material utilised to produce the hot mix asphalt concrete described in this specification.

3.2 Aggregates

Aggregates shall be crushed pit run or quarried stone or sand conforming to the quality requirements of this specification. All aggregates shall be free from coatings of clay, silt or other deleterious organic matter.

The Contractor shall submit to the Halifax Regional Municipality the location of all proposed aggregate sources at the commencement of each construction season. Any subsequent aggregate source changes must be requested in writing to HRM prior to material acceptance.

.1 Fine Aggregates

Fine Aggregate shall consist of clean, tough, rough-surfaced grains, free from clay, loam and other foreign

matter. The portion of the material passing the 5 mm sieve shall be known as fine aggregate.

Fine aggregate shall conform to the physical requirements as stipulated in Table 1.

| Table 1 - Fine Aggregate Physical Requirements⁽¹⁾ | | |
|---|----------------------------------|------------------------|
| Material Property | Test Method⁽²⁾ | Specified Value |
| Absorption | ASTM C 128 | < 2.000 |
| Angularity ⁽³⁾ | AASHTO T 304(A) | ≥45.0 |
| Sand Equivalent | ASTM D 2419 | ≥50 |
| Soundness ⁽⁴⁾ | ASTM C 88 | <10 |
| Micro Deval | ASTM D7428-15 | <20 |

(1) Applies to each individual aggregate component in the asphalt mixture

(2) Latest Addition

(3) Does not apply to Natural Blend Sand Component

(4) Test to be conducted utilizing Sodium Sulphate (NaSO₄)

.2 Coarse Aggregates

Coarse Aggregate shall consist of hard, durable crushed stone or crushed gravel particles, reasonably uniform in quality and free from soft or disintegrated pieces. The portion of material retained on the 5 mm sieve shall be known as coarse aggregate.

Coarse Aggregates shall conform to the physical requirements as stipulated in Table 2.

| Table 2 - Coarse Aggregate Physical Requirements | | |
|---|--------------------|------------------------|
| Material Property | Test Method | Specified Value |
| Absorption | ASTM C 127 | < 1.750 |
| Petrographic Number ⁽⁵⁾ | NSTIR TM2 | ≤ 135 |
| Los Angeles Abrasion | ASTM C 131 | < 30 |
| % Fractured Particles | NSTIR TM3 | > 95 |
| Flat or Elongated Particles | ASTM D 4791 | < 10 |
| Micro Deval | ASTM D 6928 | < 20 |
| Aggregate Soundness ⁽⁶⁾ | ASTM C 88 | < 15 |

(5) Coarse Aggregate Sources may be blended to meet Petrographic Number

(6) Test to be conducted utilizing Sodium Sulphate (NaSO₄)

.3 Gradation of Combined Aggregate

The gradation of the combined processed aggregate for the asphalt concrete shall conform to the values shown in Table 3 when tested by washed sieve analysis according to ASTM C 117, C 136 and D 546.

| Table 3 - Combined Processed Aggregate Gradations for Each Mix Type⁽⁷⁾ | | | | |
|--|-----------------------------------|-------------|------------------|-------------|
| Sieve Size (µm) | Cumulative Percent Passing | | | |
| | B-HF | C-HF | Special C | D-HF |
| 28000 | 100 | | | |
| 20000 | 95-100 | 100 | 100 | |
| 14000 | 80-90 | 95-100 | 95-100 | 100 |
| 10000 | 68-80 | 75-90 | 80-95 | 95-100 |
| 5000 | 47-63 | 52-68 | 58-76 | 60-80 |
| 2500 | 30-46 | 30-50 | 35-56 | 35-58 |
| 1250 | 18-35 | 18-35 | 22-40 | 20-40 |
| 630 | 12-24 | 10-25 | 15-28 | 14-28 |
| 315 | 8-16 | 7-15 | 10-20 | 8-18 |
| 160 | 5-10 | 4-10 | 6-12 | 6-12 |
| 80 | 3-6.5 | 3-6.5 | 4-7.5 | 4-7.5 |

(7) A maximum of 15% natural sand will be permitted to achieve required gradation

.4 Mineral Filler

Mineral filler, when required, shall comprise finely divided mineral matter such as rock dust, hydrated lime, hydraulic cement, pozzolanic material, fly ash or other suitable mineral matter. All mineral fillers must conform to the requirements of ASTM D 242, Standard Specification for Mineral Filler for Bituminous Paving Mixtures. All mineral fillers utilised must have a plasticity of zero.

.5 Performance Graded Asphalt Binder (PGAB)

The asphalt cement shall be prepared by the refining of petroleum. The Contractor will be responsible for the supply and transportation of the PGAB. Material storage, transportation and material properties will comply with HRM's Performance Graded Asphalt Binder Specification, Section S-2.

.6 Reclaimed Asphalt Pavement (RAP)

The Contractor will be permitted to use Reclaimed Asphalt Pavement (RAP) in the base course HMA and surface course HMA. The RAP content in the pavement mixture will be limited to 20% in each lift. HMA mixes inclusive of RAP will be subject to the following conditions:

Preparation and submission of a Marshall Asphalt Design Mix Formula and Lottman (including all supporting documentation) for the asphalt mixture containing RAP, for HRM's approval, is the responsibility of the Contractor. The Contractor shall use professional engineering services and a qualified testing laboratory to assess the aggregate materials, asphalt binders, blending sands, mineral fillers, anti-stripping agents and asphalt cement rejuvenation agents proposed for use and to carry out the design of the asphalt concrete mix. No compensation will be provided to the contractor for the production of the asphalt design mix formula for the HMA containing RAP.

The asphalt mixture containing RAP shall be designed in accordance with the Ontario Ministry of Transportation Design Procedure for Recycled Hot Mix Asphalt, latest edition, except that all test methods referred to shall be replaced with the appropriate ASTM Standards.

The asphalt plant must be equipped with a metering system that allows the RAP to be added in a controlled manner acceptable to the Engineer.

.7 Tack Coat

.1 Local Roads Tack Requirements

Non-Tracking Emulsion Requirements (Prior to Dilute)

| Table 4 - Local Roads Tack Requirements Non-Tracking Emulsion Requirements (Prior to Dilute) | | |
|---|----------------------------|----------------|
| Test Type | Specification Range | |
| | Minimum | Maximum |
| Test on Emulsion | | |
| SF Viscosity, 25°C, SFs | 20 | |
| Sieve Test | | 0.1 |
| Dist. Residue | 55 | |
| Oil Portion of Dist., % | | Trace |
| Particle Charge | (-) or (+) | |
| Test on Residue | | |
| Penetration, 25°C, dmm | 20 | 55 |
| Ash Content, % | | 1.0 |

*Non-tracking tack can be used on all other road classifications

.2 Minor/Major Collectors and Arterials Tack Requirements

Rapid Setting Emulsified Asphalt (RS-1) Requirements

| Table 5 - Minor/Major Collectors and Arterials Tack Requirements Rapid Setting Emulsified Asphalt (RS-1) Requirements | | |
|--|----------------------------|----------------|
| Test Type | Specification Range | |
| | Minimum | Maximum |
| SF Viscosity, 25°C, SFs | 20 | 100 |
| Dist. Residue | 55 | |
| Storage Stability, % | | 1.5 |
| Sieve Test, % | | 0.1 |
| Demulsibility, % | 60 | |
| Particle Charge | Negative | |
| Penetration, 0.2mm | 100 | 200 |
| Ductility, cm | 60 | |
| Solubility, % | 97.5 | |

PART 4 - MIX DESIGN REQUIREMENTS

The Contractor shall undertake a laboratory-based mix design based on current aggregate stockpiles. The mix design, in all instances, must be current and reflective of the aggregate that is to be utilised in the hot mix asphalt. The Contractor shall submit the design mix formula (DMF) to HRM at least 14 days prior to the initial start of production and for each subsequent change in supplier or source of materials. The DMF shall follow the Marshall method and achieve the properties listed in Table 6.

| Table 6 - Mix Properties Requirements⁽⁸⁾ | | | |
|--|--------------------|------------------------|---------------------|
| Property | Test Method | Specified Value | Mix Type |
| Marshall Stability @ 60°C (kN) | ASTM D6927 | > 12 | All Mixes |
| Marshall Flow (mm) | ASTM D6927 | 2.0 - 4.0 | All Mixes |
| Voids in Mineral Aggregate (%) ⁽⁹⁾ | | > 13.0 | B-HF |
| | | > 14.0 | C-HF, Special C |
| | | > 15.0 | D-HF |
| Air Voids (%) | ASTM D 2041 | 3.0 - 5.0 | B-HF, C-HF and D-HF |
| | | 2.5 - 4.0 | Special C |
| Modified Lottman Test, TSR (%) | AASHTO T 283 | > 75.0 | All Mixes |

(8) Marshall compactive effort shall be 75 blows

(9) Shall be calculated utilizing oven dry specific gravity for combined aggregate

The final DMF will be implemented as the initial trial for plant mix start up with any necessary adjustments immediately being made by the Contractor. These adjustments will be documents as the Job Mix Formula (JMF). Any additional adjustments will result in an additional documented JMF. Copies of all JMF reports will be provided to HRM.

All JMF's shall meet the requirements of Tables 3 & 6, and Subsection 4.1 of this specification. All quality control tests will be measured against the documented JMF.

4.1 Field Mix Tolerance

Changes to the JMF shall be submitted in advance of paving. The maximum mean of the deviations of the lot from the Job Mix Formula for gradation and PGAB content in percent by mass shall be:

B-HF

| | | |
|---------------------------|-------|-------|
| Passing the 5000 µm sieve | ± 6.0 | |
| Passing the 80 µm sieve | | ± 0.8 |
| PGAB | ± 0.4 | |

C-HF, Special C, D-HF

| | | |
|---------------------------|-------|-------|
| Passing the 5000 µm sieve | ± 5.0 | |
| Passing the 80 µm sieve | | ± 0.5 |
| PGAB | ± 0.3 | |

A lot is defined as one day of production per street, with 2 samples per lot, per mix type. Where planned daily production is greater than 1000 tonne, an additional sample will be taken and the lot will be based on three (3) samples. Price adjustments will be made as detailed in the tables below:

Table 7 – Price Adjustments for Gradation

| Sieve Designation | Mean of the Deviations of the Gradation from the JMF | B-HF Price Adjustment for Gradation (\$ per Tonne) | C-HF, Special C, D-HF Price Adjustment for Gradation (\$ per Tonne) |
|-------------------|--|--|---|
| 5000 | 0.00 to 5.00 | 0 | 0 |
| | 5.01 to 5.20 | 0 | -0.25 |
| | 5.21 to 5.40 | 0 | -0.50 |
| | 5.41 to 5.60 | 0 | -0.75 |
| | 5.61 to 5.80 | 0 | -1.00 |
| | 5.81 to 6.00 | 0 | -1.25 |
| | 6.01 to 6.20 | -0.25 | -1.50 |
| | 6.21 to 6.40 | -0.50 | -1.75 |
| | 6.41 to 6.60 | -0.75 | -2.00 |
| | 6.61 to 6.80 | -1.00 | -2.25 |
| | 6.81 to 7.00 | -1.25 | -2.50 |
| | 7.01 to 7.20 | -1.50 | -5.00 |
| | 7.21 to 7.40 | -1.75 | -5.00 |
| | 7.41 to 7.60 | -2.00 | -5.00 |
| | 7.61 to 7.80 | -2.25 | -5.00 |
| | 7.81 to 8.00 | -2.50 | -5.00 |
| | 8.01 to 9.00 | -5.00 | -7.50 |
| | 9.01 to 10.00 | -7.50 | Rejection* |
| | >10.00 | Rejection* | Rejection* |

| | | | |
|----|--------------|------------|------------|
| 80 | 0.0 to 0.50 | 0 | 0 |
| | 0.51 to 0.60 | 0 | -0.50 |
| | 0.61 to 0.70 | 0 | -1.00 |
| | 0.71 to 0.80 | 0 | -1.50 |
| | 0.81 to 0.90 | -0.50 | -2.50 |
| | 0.91 to 1.00 | -1.00 | -3.75 |
| | 1.01 to 1.10 | -1.50 | -6.00 |
| | 1.11 to 1.20 | -2.50 | -6.00 |
| | 1.21 to 1.30 | -3.75 | Rejection* |
| | 1.31 to 1.50 | -6.00 | Rejection* |
| | >1.50 | Rejection* | Rejection* |

* The Engineer reserves the right to reject the work or assess double the maximum penalty outlined in the table above.

| Mean of the Deviation of the Asphalt Binder Content from the JMF | B-HF Price Adjustment for Asphalt Binder Content (\$ per Tonne) | C-HF, Special C, D-HF Price Adjustment for Asphalt Binder Content (\$ per Tonne) |
|---|--|---|
| 0.00 to 0.30 | 0 | 0 |
| 0.31 to 0.35 | 0 | -0.50 |
| 0.36 to 0.40 | 0 | -1.00 |
| 0.41 to 0.45 | -0.50 | -1.50 |
| 0.46 to 0.50 | -1.00 | -2.50 |
| 0.51 to 0.55 | -1.50 | -3.00 |
| 0.56 to 0.60 | -2.00 | Rejection* |
| 0.61 to 0.65 | -2.50 | Rejection* |
| 0.66 to 0.70 | -3.00 | Rejection* |
| >0.70 | Rejection* | Rejection* |

* The engineer reserves the right to reject the work or assess double the maximum penalty outlined in the table above.

HRM’s testing company will take duplicate samples in the event of an appeal. Appeals shall be sent in writing to HRM within five (5) business days of receiving test results. Should the price adjustment remain the same or increase, based on the new results, the Contractor will be responsible for the new price adjustment plus the cost of the additional sampling and testing. Should the price adjustment be eliminated or reduced based on the new results, the cost of the sampling and testing will be borne by HRM. Loose mix samples shall not be taken from the first or last loads of the day. On

projects where less than 300 tonne of asphalt is placed, price adjustments for gradation and asphalt cement shall not apply. For projects with tonnage greater than 1200 t per mix type, the contractor may elect to complete up to a 300 t trial prior to submitting the job mix formula.

4.2 Anti-Stripping Agents

An anti-stripping additive may be required in the Hot Mix Asphalt Concrete. Resistance of Compacted Hot Mix Asphalt to Moisture-Induced Damage tests in accordance with AASHTO T283 shall be completed following the mix design procedure, to determine the need for and the required amount of anti-stripping additive. An anti-stripping agent will be required if the tensile strength ratio of the asphalt concrete is less than 75%, as determined by AASHTO T 283. Additionally, the tested specimens are to be inspected by the firm conducting the mix design for any visual evidence of moisture damage as evidence by the loss of asphalt coating on the aggregate matrix. If coating loss is evident, the test procedure is to be repeated incorporating an approved anti-stripping agent. The testing procedure is repeated at increments of 0.2% LAS, or 0.5% lime until such time that the moisture damage is not evident. An asphalt mixture will also require the addition of an approved anti-stripping agent if based on past knowledge that the aggregate source is susceptible to moisture damage.

Either hydrated lime ($\text{Ca}(\text{OH})_2$) or approved liquid anti-strip additives can be utilised.

Where stripping tests are deemed necessary, the Contractor must submit a report to the Engineer summarizing the test results. The report must contain, as a minimum, the following:

- The source and percentage of aggregates used within the proposed asphalt concrete;
- The type and percentage of asphalt binder used;
- The percentage of air voids for both the untreated and treated mix;
- The average tensile strength of both the treated and untreated mix;
- The Tensile Strength Ratio (TSR); and
- Visual inspections of any moisture damage.

Where liquid anti-stripping agents are required as an additive to the PGAB, the dosage added will be the minimum dosage required to satisfy the above criteria.

Contractors electing to utilize liquid anti-stripping agents in their PGAB are required to ensure all appropriate safety precautions are taken in the handling, use and blending of this material. All workers are to be formally trained with respect to working with PGAB containing liquid anti-stripping additives.

Where hydrated lime is used as an anti-stripping agent, the dosage requirement shall be the greater of one half ($\frac{1}{2}$) percent by mass of total dry aggregate, or the recommended percentage as determined from AASHTO T283 test results.

Where hydrated lime is utilised, the hydrated lime shall be added to the aggregates by the dry method or the wet method.

For the dry method, lime shall be taken from the lime storage facility and combined with aggregate with an appropriate mixing device. Prior to the addition of the hydrated lime, the aggregate source must be dampened to improve aggregate coating.

For the wet method, a slurry containing one part hydrated lime to three parts water by mass shall be used. The slurry shall be prepared in a central mixing tank. When the wet method of lime addition is utilised, no addition of water to the aggregate prior to the mixing of the slurry mix and aggregate will be required.

Both the coarse and fine aggregate components must be treated if an anti-stripping agent is required.

PART 5 - TRANSPORTATION, PLACEMENT AND CONSTRUCTION

5.1 Transportation of Hot

Mix Asphalt

The Hot Mix Asphalt shall be transported from the mixing plant to the work site in tight vehicles with the bottoms cleaned of all foreign materials. Vehicles shall be equipped with tarpaulins of water-repellent material with a maximum mesh size of 0.5 mm when stretched, a minimum melting point of 200°C and of sufficient size to completely cover truck bodies from edge of box to edge of box and about the tailgate.

Tarps shall be in good condition and shall have no holes or tears. The tarps shall be securely tied down so there is no visible opening between the truck box and tarp. Vehicles shall also be equipped with wind deflectors at the front of the truck box. Tarpaulins must always be used during the transportation of hot mix asphalt to the respective job site unless otherwise stated by the Engineer.

The use of hydrocarbon-based fuels or solvents to lubricate the truck bodies or to clean tools or equipment will not be permitted. A biodegradable release agent shall be supplied by the Contractor to clean or lubricate tools, equipment and truck bodies.

In no case shall the temperature of the Hot Mix Asphalt/Warm Mix Asphalt exceed 165°C. Hot Mix Asphalt shall have temperatures of at least 125°C immediately prior to loading into the spreader hopper. Warm Mix Asphalt shall have temperatures of 105°C immediately prior to loading into the spreader hopper.

5.2 Placing of Hot Mix Asphalt

The mixing and compaction temperature ranges for the Marshall Mixtures shall be determined from the supplier temperature-viscosity charts current for the calendar year. Laboratory asphalt mixing shall occur within temperature ranges such that the viscosity of the PGAB is 170 ± 20 centistokes. Asphalt compaction shall occur within temperature ranges such that the viscosity of the PGAB is 280 ± 30 centistokes.

Asphalt concrete shall be placed upon a prepared gravel surface, which is free from standing water, and cleaned of all loose or foreign material including fine dust. Hand sweeping, power sweeping, power blowers, vacuum sweepers and/or pressure washers may be required between successive lifts of asphalt or on milled surfaces when deemed necessary by the Engineer.

Asphalt concrete shall be placed upon a milled and/or existing asphalt surface, which is dry, and cleaned of all loose or foreign material including fine dust. Hand sweeping, power sweeping, power blowers, vacuum sweepers, and/or pressure washers may be required between successive lifts of asphalt or on milled surfaces when deemed necessary by the Engineer, prior to placement of tack coat.

Placement shall not take place during rain, after October 31, or when the ambient temperature is below 5°C , unless otherwise directed by the Engineer.

Where a Hot Mix Asphalt is to be placed as an overlay to an existing asphalt wearing or milled surface, a tack coat must be applied to the surface prior to the placement of the Hot Mix Asphalt. Tack coat as per NSTIR specification Division 4, Section 1 for Rapid Setting Emulsified Asphalt RS-1. The method of application shall be as recommended by the manufacturer and shall be subject to the approval of the Engineer. The tack coat utilised must be appropriate for the prevailing weather conditions.

New pavement may be applied directly over a freshly placed mat without applying a tack coat when multiple lifts are being placed and the fresh mat is free of any type of contamination or debris. However, a tack coat must be applied if more than 24 hours expires between consecutive lifts.

Where tack coat is required by the Engineer, an application rate of 0.25 L/m^2 for non-tracking and 0.15 L/m^2 for RS-1 shall be utilized. On milled surfaces the application rate shall be increased to 0.30 L/m^2 for non-tracking and 0.20 L/m^2 for RS-1.

The placing of asphalt concrete shall be at a constant and even rate of speed compatible with the rate of compaction rolling and plant output.

Asphalt concrete ramps shall be installed at all limits including side streets and pedestrian ramps using hot mix asphalt (or approved equivalent) and a bond separator. Asphalt ramps are to be installed before work is completed for the day, and before the area is opened to live traffic. Asphalt ramps to be constructed to at least a 20 to 1 horizontal to vertical ratio.

5.3 Thickness Requirements The maximum thickness allowed for any one lift of hot mix asphalt shall be 75 mm unless otherwise approved by the Engineer.

For new construction as well as paving atop a milled surface, the average compacted thickness of the hot mix asphalt mat shall be within 5 mm with all core results within 10 mm of the thickness as specified by the contract documents or by the Engineer. Based on the thickness test results determined by the Engineer’s testing agency, the following unit price adjustment table will be applied:

| Table 9 - Thickness Price Unit Price Adjustments⁽¹⁰⁾⁽¹¹⁾ | |
|--|--|
| Scenario of Core Results | Price Adjustment / square metre |
| 1) Average Core Results greater than total specified thickness | +\$0.30 / mm) ⁽¹²⁾ |
| 2) Average Core Results deficient more than 5 mm relative to the total specified thickness | -\$0.30 / mm) ⁽¹³⁾ |
| 3) For each individual Core Result deficient more than 10 mm relative to the total specified thickness | (-\$0.50 / mm ⁽¹⁴⁾) / (total # of core samples taken on project) |

⁽¹⁰⁾ Items 1 & 2 will not apply on projects in which hot mix asphalt payment is on a per mass (metric tonne) basis.

⁽¹¹⁾ Table will be applied in numerical order. When item 2 applies, item 3 will not be applied on the same project. Items 1 and 3 will each be applied on a project if applicable.

⁽¹²⁾ Applied to a maximum of 5 mm or \$1.50 / m² unit price adjustment. No price adjustment will be applied if any compaction penalty applies.

⁽¹³⁾ Thickness deviation will be difference between average and specified thickness.

⁽¹⁴⁾ Thickness deviation on individual core results is as follows:

[(Specified Thickness - 10 mm tolerance) - Actual Thickness]

.1 Dispute Resolution

Should the Contractor wish to appeal the original thickness results obtained the following option is available. Within five business days of receiving the quality assurance test results from the Engineer’s testing agency the Contractor may request in writing to the HRM Construction Supervisor appeal sampling for thickness determination. The specific core sample locations to be appealed shall be identified by the Contractor and will be sampled by the Engineer within

one metre of the original sample location. The original thickness result will be discarded from the data set and replaced with the new result determined during the appeal testing.

.2 Appeal Testing Process

The Engineer will coordinate the additional testing with their testing agency and the Contractor. The Contractor may have a representative present during the time of the appeal sampling and testing to verify the accuracy of the test method. Should the Contractor's representative take issue with the test procedures utilized in the appeal testing, they must provide the issue in writing prior to leaving the QA testing laboratory. Any concerns identified will be reviewed by the Engineer to determine the appropriate action. Concerns identified in writing or otherwise raised by the Contractor after leaving the QA laboratory will not be considered by the Engineer.

.3 Cost of Appeal Testing

Should the thickness price adjustment remain the same or increase, based on the new results, the Contractor will be responsible for the new price adjustment plus the cost of the additional sampling and testing. Should the price adjustment be eliminated or reduced based on the new results, the cost of the sampling and testing will be borne by HRM.

5.4 Placement by Hand

Where areas are not accessible by equipment, hand placement will be permitted. Care must be taken during hand placement to avoid segregation of the coarse and fine aggregate. Lutes and rakes must be utilised during hand placement to thoroughly loosen and uniformly distribute the mix. Any lumps that do not readily break down must be removed.

All hand tools must be heated prior to hand placement operations to keep them free from sticking asphalt. Care must be taken when heating the tools to ensure the mix is not overheated.

Prior to rolling, the surface must be checked with a straightedge for level, and any irregularities must be corrected.

5.5 Compaction

Compaction of the asphalt concrete shall be with any combination of rollers that can achieve the specified smoothness and density. However, the Contractor is encouraged to utilise a fully functional pneumatic tire roller on all paving projects. A 'paving' project shall be defined as a contract which involves full-width replacement or overlay of new HMA.

Trench reinstatement or partial-width road paving will be considered 'patching' projects.

The Contractor shall demonstrate a rolling pattern for achieving compaction at the start of paving operations, and the degree of compaction will be verified by the Engineer.

Rollers shall be in good condition, capable of reversing direction without backlash, and they shall be operated by competent and trained operators. The speed of steel-wheeled rollers and pneumatic rollers shall not exceed 5 km/h. The speed shall be slow enough to avoid displacement of the asphalt concrete. Any displacement occurring as a result of reversing the direction of the roller, or from any other cause, shall be corrected.

Rolling shall proceed continuously until all roller marks are removed and the specified compaction is achieved.

Water or a biodegradable release agent shall be used on the roller wheels or tires to prevent adhesion of asphalt concrete. Hydrocarbon fuels or solvents shall not be permitted.

Breakdown rolling shall take place as closely behind the laying machine as the temperature and condition of the mat will allow.

Secondary rolling shall follow the breakdown rolling as closely as possible while the asphalt concrete is still viscous enough to achieve the specified compaction.

Final rolling shall be performed while the asphalt concrete is still viscous enough to permit the removal of roller marks.

Sufficient rollers must be maintained on the job site to ensure full compaction of the asphalt mix before the temperature of the mix falls below 80°C.

The surface, after final rolling, shall be smooth and true to the established crown and grade.

All defective areas shall immediately be repaired by removing the asphalt concrete and replacing it with the same type of hot mix asphalt concrete used in that particular lift as per the specifications.

The surface shall be free from roller marks or any depressions exceeding 5 mm when measured with a 3 m straight edge held parallel to the centerline. A lower surface tolerance may be accepted with 5 m of iron works at the discretion of the Engineer.

The surface shall have a cross slope of 20 mm/m to 35 mm/m or as specified by the Engineer (in areas of normal crown).

.1 Compaction Requirements

The minimum density acceptable shall be 92.0% of the theoretical maximum density determined according to ASTM D 3203. The percent compaction shall be determined by comparing the core densities with the average theoretical maximum relative density determined from the recovered field samples from each day's production of any given mix designation.

A bonus will be paid if the average density of all cores is above 92.0% with no individual cores below 91.0%. If any core results fall below 88.5% the Contractor shall either repair, remove and replace or recap the deficient sections at the Contractor's expense subject to the approval of the Engineer, or the Contractor shall be penalized by HRM as outlined in Table 10.1. No bonus will be applied if thickness penalty applies.

Core compaction results shall be based on 1 core sample per 1,500 m², with a minimum of 5 core samples per project or area of consideration. Connecting streets shall be considered as one project, with a minimum of 2 cores per street.

At the discretion of the Engineer rejected asphalt concrete can remain in place without payment to the contractor.

| Table 10.1 - Compaction Unit Price Adjustments (per metric tonne)⁽¹⁵⁾⁽¹⁶⁾ | | | | |
|---|---------------------------------|-------------|-------------|------------|
| Average Compaction of Cores less than 92.0% of MTD | Percentage of Cores ≥ 92.0% MTD | | | |
| | 60.0 - 79.9 | 40.0 - 59.9 | 20.0 - 39.9 | 0.0 - 19.9 |
| 91.9 | -\$0.96 | -\$1.92 | -\$2.88 | -\$3.84 |
| 91.8 | -\$1.08 | -\$2.16 | -\$3.24 | -\$4.32 |
| 91.7 | -\$1.20 | -\$2.40 | -\$3.60 | -\$4.80 |
| 91.6 | -\$1.32 | -\$2.64 | -\$3.96 | -\$5.28 |
| 91.5 | -\$1.44 | -\$2.88 | -\$4.32 | -\$5.76 |
| 91.4 | -\$1.56 | -\$3.12 | -\$4.68 | -\$6.24 |
| 91.3 | -\$1.68 | -\$3.36 | -\$5.04 | -\$6.72 |
| 91.2 | -\$1.80 | -\$3.60 | -\$5.40 | -\$7.20 |
| 91.1 | -\$1.92 | -\$3.84 | -\$5.76 | -\$7.68 |
| 91.0 | -\$2.04 | -\$4.08 | -\$6.12 | -\$8.16 |
| 90.9 | -\$2.16 | -\$4.32 | -\$6.48 | -\$8.64 |
| 90.8 | -\$2.28 | -\$4.56 | -\$6.84 | -\$9.12 |
| 90.7 | -\$2.40 | -\$4.80 | -\$7.20 | -\$9.60 |
| 90.6 | -\$2.52 | -\$5.04 | -\$7.56 | -\$10.08 |
| 90.5 | -\$2.64 | -\$5.28 | -\$7.92 | -\$10.56 |
| 90.4 | -\$2.76 | -\$5.52 | -\$8.28 | -\$11.04 |
| 90.3 | -\$2.88 | -\$5.76 | -\$8.64 | -\$11.52 |
| 90.2 | -\$3.00 | -\$6.00 | -\$9.00 | -\$12.00 |
| 90.1 | -\$3.20 | -\$6.40 | -\$9.60 | -\$12.80 |
| 90.0 | -\$3.40 | -\$6.80 | -\$10.20 | -\$13.60 |
| 89.9 | -\$3.60 | -\$7.20 | -\$10.80 | -\$14.40 |
| 89.8 | -\$3.80 | -\$7.60 | -\$11.40 | -\$15.20 |
| 89.7 | -\$4.00 | -\$8.00 | -\$12.00 | -\$16.00 |
| 89.6 | -\$4.20 | -\$8.40 | -\$12.60 | -\$16.80 |
| 89.5 | -\$4.40 | -\$8.80 | -\$13.20 | -\$17.60 |
| 89.4 | -\$4.60 | -\$9.20 | -\$13.80 | -\$18.40 |
| 89.3 | -\$4.80 | -\$9.60 | -\$14.40 | -\$19.20 |
| 89.2 | -\$5.00 | -\$10.00 | -\$15.00 | -\$20.00 |
| 89.1 | -\$5.30 | -\$10.60 | -\$15.90 | -\$21.20 |

| | | | | |
|-------|-----------|-----------|-----------|-----------|
| 89.0 | -\$5.60 | -\$11.20 | -\$16.80 | -\$22.40 |
| 88.9 | -\$5.90 | -\$11.80 | -\$17.70 | -\$23.60 |
| 88.8 | -\$6.20 | -\$12.40 | -\$18.60 | -\$24.80 |
| 88.7 | -\$6.50 | -\$13.00 | -\$19.50 | -\$26.00 |
| 88.6 | -\$6.80 | -\$13.60 | -\$20.40 | -\$27.20 |
| 88.5 | -\$7.10 | -\$14.20 | -\$21.30 | -\$28.40 |
| <88.5 | Rejected* | Rejected* | Rejected* | Rejected* |

* The engineer reserves the right to reject the work or assess double the maximum penalty outlined in the table above.

⁽¹⁵⁾ \$1.20 per metric tonne bonus will be extended should the average of all cores in the project area of consideration meet or exceed 92.0% with no individual core below 91.0%.

⁽¹⁶⁾ Additional cores will be taken by HRM to delineate poorly compacted area(s) to be removed, irrespective to percentage of cores applicable.

.2 Analysis of Rejected Asphalt Concrete Mix

The Contractor is responsible for any Asphalt Concrete Mixture with low compaction deemed 'rejected' by Table 10.1. The Engineer will sample additional cores to delineate location(s) with low density. The delineated area determined by all the core results will dictate where asphalt concrete mix is to be milled and replaced with the equivalent mix type. Replacement mixtures will be subject to testing.

.3 Dispute Resolution

Should core compaction results obtained on a project result in a unit price adjustment that is considered unfavourable by the Contractor, the Contractor may request a review of the project data. This request must be sent to HRM's Construction Supervisor in writing within five business days of receipt of the test results from the Engineer's testing agency. Following this request, the Engineer will review the 'Asphalt Concrete Pavement Inspection Checklist(s)' completed for the day(s) of HMA placement in which the core samples were retrieved.

Should the inspection checklist detail satisfactory paving practices to achieve compaction, additional core samples will be recovered by the Engineer's representative within one metre of the original sample location in question and tested at HRM's designated laboratory. The original compaction result will be discarded from the data set and replaced with the new result determined during the appeal testing.

Should the inspection checklist detail paving practices determined by the Engineer to be unsatisfactory, no appeal of results will be permitted, and the negative unit price adjustment will stand.

The use of a full rubber tire pneumatic roller during pavement laydown is considered best practice and required for consideration of compaction appeal.

.4 Appeal Testing Process

The Engineer will coordinate the additional testing with their testing agency and the Contractor. The Contractor may have a representative present during the time of the appeal sampling and testing to verify the accuracy of the test method. Should the Contractor's representative take issue with the test procedures utilized in the appeal testing, they must provide the issue in writing prior to leaving the QA testing laboratory. Any concerns identified will be reviewed by the Engineer to determine the appropriate action. Concerns identified in writing or otherwise by the Contractor after leaving the QA laboratory will not be considered by the Engineer.

.5 Cost of Appeal Testing

Should the thickness price adjustment remain the same or increase, based on the new results, the Contractor will be responsible for the new price adjustment plus the cost of the additional sampling and testing. Should the price adjustment be eliminated or reduced based on the new results, the cost of the sampling and testing will be borne by HRM.

5.6 Joints

Joints shall be constructed in a careful and workmanlike manner by experienced and competent personnel. Joints shall be smooth, well-bonded and tightly sealed.

.1 Transverse Joints

Transverse joints shall be formed by butt joints. When forming butt joints, the edge of the previously placed asphalt concrete shall be cut back to its full depth so as to expose a fresh surface after which it shall be coated with tack coat or heated before fresh asphalt concrete is placed in contact with it. Heat shall be applied to the joint using a method approved by The Engineer, with care taken not to overheat the existing asphalt concrete. The freshly placed asphalt concrete shall be raked to the proper depth and grade and then the transverse joints shall be rolled transversely (perpendicular to the travel lanes) and the compacted joint

shall be inspected with a 3 m straightedge. If there is more than a 6 mm depression, the joint shall be reconstructed.

Should any separation of the construction joint be present on or before 2 years after 100 percent completion of the project section, the Contractor will be required to undertake the following corrective action at their own cost prior to the end of the current construction year:

| Table 11 - Joint Rehabilitation under Warranty Period | |
|--|---|
| Gap in Construction Joint | Required Corrective Action |
| 3 - 20 mm | The affected joint must be cleaned, hot-air lanced, and filled with appropriate sealant |
| > 20 mm | Milled, tacked and replaced with equivalent HMA at a minimum width of 300 mm |

.2 Keyed Joints

When overlaying existing asphalt concrete pavement, keyed joints shall be constructed at both ends of the Project repaved area, at all intersecting roads, ramps, and at all bridge decks in the repaved area, to avoid a feather joint. Keys will only be required between the final lift of pavement and the existing pavement, unless otherwise directed by the Engineer.

The existing asphalt concrete pavement shall be removed to expose a vertical surface of a depth equal to the thickness of the final lift against which new asphalt concrete may be placed. The minimum slope measured parallel to the centerline of the milled area shall be 200 horizontal to 1 vertical (200H:1V). The angle that the joint makes with the centerline shall not exceed forty-five degrees (45°) or as otherwise directed by the Engineer.

When existing pavement has been removed in advance of paving the joint area, the Contractor shall construct a smooth asphalt taper at the joint area to a slope of at least 20 horizontal to 1 vertical (20H:1V). The taper may be placed on tar paper and shall be removed just prior to paving the keyed area or as directed by the Engineer. The transverse joint shall be straight and have a vertical face when the taper is removed.

The associated cost of providing all keys shall be included in the price per tonne of asphalt concrete.

The paver shall not move more than 20 m from any transverse joint until that joint has been rolled and checked with a straight edge. If the joint is not satisfactory, it shall be immediately corrected before the paver may proceed.

.3 Longitudinal Joints

Longitudinal Joints with temperatures less than 60°C must be tacked prior to placement of the successive mat. Adjacent mats must be completed to provide for exposed joint edges of maximum length of 100 m at the end of each day. When paving is conducted on multi-lane roads, the maximum length of permissible edge mat at the end of each day will be increased should the Engineer deem it safe to do so. The Contractor will not be permitted to leave exposed joints longer than 24 hours should conditions permit paving the following working day. Multi-lane roads are defined as roads with widths requiring more than two mat widths to traverse the full width of pavement.

Where practical, pavers may be used in echelon to lay full-width pavement sections, when traffic can be diverted and when production of the mixture can be maintained. Echelon paving may require a road closure permit if traffic cannot be maintained. The pavers shall follow one behind the other close enough that cooling of the longitudinal joints between the mats is minimized and in no case is less than 125°C. Adjacent mats must be completed to provide for exposed joint edges of maximum length of 100 m at the end of each day.

Should any separation of the construction joint be present on or before 2 years after 100 percent completion of the project section, the Contractor will be required to undertake the following corrective action at their own cost prior to the end of the current construction year:

| Table 12 - Joint Rehabilitation under Warranty Period | |
|--|---|
| Gap in Construction Joint | Required Corrective Action |
| 3 - 20 mm | The affected joint must be cleaned, hot-air lanced, and filled with appropriate sealant |
| > 20 mm | Milled, tacked and replaced with equivalent HMA at a minimum width of 300 mm |

PART 6 - QUALITY CONTROL / QUALITY ASSURANCE6.1 General

All workmanship and all materials supplied under this specification are subject to close and systematic inspection by the Engineer. The Engineer shall be afforded full access both at the Site and any production plant to determine whether the material being supplied is in accordance with this specification.

All materials supplied under this specification shall be subject to testing and approval by the Engineer.

6.2 Quality of Asphaltic Concrete Paving Mixture

The Engineer shall obtain samples of the asphaltic concrete paving material and of the constituent materials (aggregates and PGAB) for quality assurance testing purposes.

The frequency and number of quality assurance tests shall be determined by the Engineer.

The physical properties of the asphaltic concrete mixture and constituent materials must meet the requirements listed in section 3.0 of this specification.

6.3 Quality of Asphaltic Concrete Compacted Pavement

Pavement core specimens shall be taken from each compacted pavement course by the Engineer. Holes left as a result of sample removal must be filled with hot mix asphalt and thoroughly compacted by the Engineer.

The thickness and percent compaction of the as-placed asphaltic concrete mix must meet the requirements listed in Section 3.0, 4.0 & 5.0 of this specification.

Core specimens shall not be sampled within 600 mm of longitudinal joints and edge of pavements, 10 m from transverse joints, or 1.5 m from ironworks. HRM reserves the right to request cores on patching and reinstatement for hardware adjustments and curb placement. Cores with compaction results below 88.5% will be removed and replaced by the Contractor at no additional cost to the Owner.

PART 7 - PRICE ESCALATION / DE-ESCALATION - PERFORMANCE GRADED ASPHALT BINDER (PGAB)

The Contractor may be assessed a price increase or decrease for asphalt concrete mix placed under this contract (not including off road asphalt work if the tonnage is less than 200 tonne), if the Monthly Asphalt Binder Rack Price (MABRP) for the PGAB specified differs by more than \$10.00 per tonne of PGAB, from the month prior to the month in which this tender closes and the month(s) in which the asphaltic concrete placement is performed. The MABRP will be the weighted average posted rack price established for the month, based on the rack prices provided by each approved supplier. This information can be reviewed on the Nova Scotia Department of Transportation & Infrastructure Renewal website at the end of each month: www.gov.ns.ca/tran.

Participation in the price escalation / de-escalation program for performance graded asphalt binder (PGAB) used in asphaltic concrete mix is mandatory.

HRM's assessment of a price increase/decrease will be based on the difference between the posted weighted average MABRP for the month prior to the month in which the tender closes, and the weighted average MABRP for the month(s) in which the asphaltic concrete placement is performed.

Price differentials will only be applied for MABRP differences of \$10.00 or more per tonne of PGAB. Corresponding amounts will be calculated based on the number of tonnes of asphalt concrete mix placed and accepted by the Engineer multiplied by \$0.50 per tonne of hot mix for each full \$10.00 incremental difference in the posted MABRP.

Where the contract unit rate for asphaltic concrete is by the square metre, conversion to tonnes shall be calculated based on the measured surface area of asphalt placed multiplied by the average thickness determined from the cores multiplied by 2.3 tonnes per cubic metre.

Price adjustments due to the Contractor or amounts owing to HRM will be paid/recovered when all the asphaltic concrete placement is completed.

Asphaltic concrete associated with vertical deflections including, but not limited to speed humps and tables, will not be included or considered for escalation/de-escalation.

All efforts shall be taken to complete the work in a timely manner and price adjustments will not be applied for any time periods where liquidated damages are being charged.

Examples of price adjustment calculations follow:

Example #1

1. Project tender closed June 5
2. Paving work carried out in June and July (total of 5,000 tonnes of hot mix)
3. 3,000 tonnes of hot mix placed in June and 2,000 tonnes placed in July
4. MABRP for PG 58-28 posted for month of May is \$598.71
5. MABRP for PG 58-28 posted for month of June is \$593.33
6. MABRP for PG 58-28 posted for month of July is \$741.93

Weighted average price (for months in which mix was placed)
 $(3,000 \times \$593.33) + (2,000 \times \$741.93) / 5,000 = \$652.77$

Price Differential = $\$652.77 - \$598.71 = \$54.06$ or 5 full increments of \$10.00

Amount Owing to the Contractor = 5,000 tonnes x (5 x \$0.50) = \$12,500.00

Example #2

1. Project tender closed May 8
2. Paving work carried out in June and July (total of 5,000 tonnes of hot mix)
3. 3,000 tonnes of hot mix placed in June and 2,000 tonnes placed in July.
4. MABRP for PG 58-28 posted for month of April is \$500.00
5. MABRP for PG 58-28 posted for month of May is \$500.00
6. MABRP for PG 58-28 posted for month of June is \$493.33
7. MABRP for PG 58-28 posted for month of July is \$475.00

Weighted average price (for months in which mix was placed)
 $(3,000 \times \$493.33) + (2,000 \times \$475.00) / 5,000 = \$486.00$

Price Differential = $\$486.00 - \$500.00 = -\$14.00$ or 1 full increment of \$10.00

Amount Recovered from the Contractor = 5,000 tonnes x (1 x \$0.50) = \$2,500.00

PART 8 - WARM MIX ASPHALT

8.1 General

The following Warm Mix Asphalt products are approved for use on HRM projects:

- Evotherm 3G
- Sonne Warmmix
- Evotherm DAT
- Cecabase RT
- Advera
- ALmix Foaming Systems
- Gencor Ultraform GX
- Meeker Foaming Systems
- Astec Double Barrel Green Foaming
- Zycotherm

The contractor shall submit a WMA mix design to HRM for review a minimum of 14 days prior to use. The contractor shall inform HRM of when WMA is used on HRM projects. The WMA must meet the Marshall mix properties outlined in S1 and shall provide the manufactures recommended compaction temperatures for Marshall air void analysis.

HRM shall be notified of every project containing WMA prior to paving.

In no case shall the temperature of the Warm Mix Asphalt exceed 165°C. Warm Mix Asphalt shall have temperatures of at least 105°C immediately prior to loading into the spreader hopper.

PART 9 – WARRANTY

9.1 General

The 2-year warranty shall begin upon substantial completion of the project. During this period any failure to the asphaltic concrete including but not limited to segregation, cracking, surface deformation, spalling, delamination, debonding, and joint failure shall be repaired and/or reconstructed at the contractor's expense to the satisfaction of the Engineer. The cost of materials, hauling, labour and all other related work including traffic control required for repair and/or reconstruction of unacceptable areas shall be borne by the contractor.

Regarding lane width requirements for remediation, the minimum repair shall include replacement of the riding (surface) lift of asphaltic concrete to be removed by cold planing to the center joint. If echelon paving was specified or used the repair patch shall be measured to the centerline of the roadway. If the failure is beyond the centerline, then both lanes shall receive the same treatment. If the failure continues below the riding (surface) lift of asphaltic concrete, then both lifts shall be removed and reconstructed as necessary.

****** END OF SECTION S-1 ******

INDEX TO CLAUSES

PART 1 - GENERAL

- 1.1 Work Included
- 1.2 Related Sections
- 1.3 Reference Standards

PART 2 - SUBMISSIONS AND DESIGN REQUIREMENTS

- 2.1 Contracts Completed in Calendar Year

PART 3 - MATERIALS

- 3.1 Physical Requirements
- 3.2 General Requirements

PART 4 – CONSTRUCTION METHODS

- 4.1 Tankers, Storage Tanks

PART 5 – QUALITY CONTROL / QUALITY ASSURANCE

- 5.1 PGAB Documentation
- 5.2 Laboratory Testing Qualifications
- 5.3 Anti-Stripping Additive
- 5.4 Samples for Testing
- 5.5 Quality Control Plan
- 5.6 Basis of Initial Acceptance
 - .1 Lot Sizes
 - .2 Quality Assurance
 - .3 Disposition of Reduced/Rejected Lots
- 5.7 Appeal Testing

PART 1 – GENERAL

1.1 Work Included

This specification covers the supply and transportation of various grades of Performance Graded Asphalt Binder (PGAB) to the Contractor's plant for use in the manufacture of hot mix asphaltic concrete.

PGAB shall be comprised of asphaltic-based cement that is produced from petroleum residue either with or without the addition of non-particulate organic modifiers.

Quality Control (QC) and Quality Assurance (QA) procedures are described herein. The Contractor shall be responsible to submit the QC test results and to ensure that all materials meet specification.

Initial acceptance of PGAB shall be based on samples taken and tested by the supplier's designated laboratory, subject to the conditions detailed in this specification.

To determine final acceptance of the product, the Engineer will conduct QA testing to confirm test results supplied by the Contractor. QA testing will be conducted on a random basis from samples recovered from the Contractor's asphalt storage tank(s) located at the hot mix plant.

1.2 Related Sections

.1 Specification for Hot-Mix Asphalt Section S1

1.3 Reference Standards

.1 AASHTO M 320, Standard Specification for Performance Graded Asphalt Binder
.2 ASTM D 140, Standard Practice for Sampling Asphalt Materials
.3 ASTM D 4402, Standard Test Method for Viscosity Determination of Asphalt at Elevated Temperatures Using a Rotational Viscometer

PART 2 - SUBMISSIONS AND DESIGN REQUIREMENTS

2.1 Contracts Completed in Calendar Year

In the event that the Contractor wishes to change the source of supply during the progress of the contract, the Contractor shall apply for approval, in writing, to the Halifax Regional Municipality (HRM). Approval in writing must be given by HRM before the source of supply is changed.

Asphalt escalation/de-escalation shall be as per S-1 - Specification for Hot Mix Asphalt Concrete.

PART 3 - MATERIALS

3.1 Physical Requirements

The PGAB as outlined in Table 2 shall conform (**with or without liquid anti-stripping additive**, or other approved additives) to the requirements of AASHTO M 320; Standard Specification for Performance Graded Asphalt Binder.

3.2 General Requirements

The PGAB shall be homogeneous, free of water and any contamination and shall not foam when heated to the temperatures specified by the manufacturer for the safe handling and use of the product.

Recycled engine oil binders (REOB) are not accepted in any PGAB to be used on HRM streets and roads. All suppliers of PGAB shall provide the Engineer with certification that the PGAB supplied does not contain REOBs

PART 4 - CONSTRUCTION METHODS

4.1 Tankers, Storage Tanks

Tankers used to transport PGAB and PGAB storage tanks located at asphalt concrete mixing plants shall meet the following requirements:

- Be free from hydrocarbon fuels or solvents, such as gasoline, diesel, varsol, etc.;
- Have a sampling spigot as outlined in ASTM D 140; and
- Be equipped with thermometers, accurate and capable of reading to the nearest 2°C.

PART 5 - QUALITY CONTROL / QUALITY ASSURANCE

5.1 PGAB Documentation

For each grade of PGAB specified in the Contract, the Contractor shall supply a copy of current test data to the Engineer prior to the use of the product(s). The PGAB shall have been graded by conducting the required testing specified in AASHTO Designation M 320 (Standard Specification for Performance Graded Asphalt Binder)

5.2 Laboratory Testing Qualifications

The laboratory conducting the QC testing shall have participated in the most recent AASHTO proficiency sample correlation program for PGAB, and shall have obtained proficiency ratings in the program satisfactory to the Engineer. Alternatively, the laboratory shall have satisfactorily participated in any equivalent correlation program acceptable to the

Engineer. Documentation of the laboratory's participation and proficiency shall be provided to the Engineer upon request.

5.3 Anti-Stripping Additive

When a liquid anti-stripping agent is to be incorporated into the mix, samples of PGAB for QC or QA are to be taken after the anti-stripping agent has been added to the PGAB.

5.4 Samples for Testing

All QA samples shall be a minimum size of one litre and shall be taken from the Contractor's storage tank in accordance with ASTM D 140. Sampling will be conducted by the contractor and witnessed by the Engineer. An additional set-aside sample shall be taken by the Contractor in the event an appeal test is required. PGAB sampling will be based on a random basis with sample time supplied by the Engineer.

The Engineer will verify the sampling, package and transport all samples (including set-aside samples) for QA testing.

5.5 Quality Control Plan

The contractor shall provide a QC Plan to the Engineer detailing the quality control activities related to the use of PGAB. The Supplier's QC Plan may be used for this purpose, provided that specific storage/handling details, etc. are furnished by the Contractor. The QC Plan shall be submitted at least seven (7) days prior to the start of the construction season. Hot mix production shall not commence until the QC Plan is accepted by the Engineer.

As a minimum, the QC Plan shall provide the following information:

- The type of facility from which the product(s) will be supplied (refinery, terminal) and its location.
- The method and frequency for initial testing, specification compliance testing and any other testing employed to either guide the manufacturing process of the PGAB or to ensure the on-going compliance of the product(s) to Table 2.
- If specification compliance testing is carried out prior to shipping the product(s) from the Supplier's facility to the hot mix plant, the QC Plan shall provide an outline of the procedures to be followed for checking transport vehicles before loading to prevent contamination of shipments.
- The QC Plan shall provide an outline of procedures detailing how anti-strip additive products and dosage rates will be identified on shipping documentation. Tests employed to ensure compliance of the product(s)

to Table 2 after anti-strip additives are incorporated in the product(s) shall be identified.

- The QC Plan shall detail the methods to be used to identify and provide for the exclusion of materials which do not conform to specifications, prior to incorporating into the hot mix. The QC Plan shall also detail how such materials will be identified and dealt with in the event that they are inadvertently incorporated into the hot mix. The QC Plan shall detail how such occurrences will be documented, and the methods of disposition of such materials.

5.6 Basis of Initial Acceptance

Initial acceptance of PGAB will be based on QC test results submitted to the Contractor, subject to the conditions specified herein. The Contractor shall be responsible to submit the Supplier's QC test result data and to ensure that all materials meet specification. The supplied product shall meet the requirements of AASHTO Designation M 320 (Standard Specification for Performance Graded Asphalt Binder) for the specified performance grade.

For initial acceptance purposes, a minimum of one complete compliance verification test shall be performed for each Supplier batch of PGAB.

.1 Lot Sizes

Lot sizes for the recovery and testing of PGAB shall be based on the total tender quantity of asphalt concrete hot mix for each grade of PGAB specified in the tender. A Lot shall be determined when the source of the PGAB is changed.

.2 Quality Assurance

QA testing will be carried out by the Engineer for the purposes of ensuring that the materials used in the work conform to the quality requirements of Table 2.

One PGAB sample shall be recovered from the plant site for every 5 000 tonnes of mix placed for HRM, with a minimum of one sample per year from each plant providing HMA to HRM. Additional samples may be taken by the Engineer at any time for QA conformance testing. All samples shall be appropriately labeled (date, time, contract, PGAB type, anti-stripping agent type/dosage) and delivered to the Engineer within 48 hours of sampling.

If a QA test result for any sample indicates non-compliance with the specification, the Engineer will advise the Contractor of the test result and may conduct a performance-graded classification to determine the actual grade of the PG binder. The additional testing will determine the actual performance high and low temperatures of the sample, rounded to the nearest 0.5 degrees Celsius.

Test results for sub-lots which do not comply with the performance grading requirements shall be categorized based on individual deviations from the design maximum or minimum temperature defined below. Price adjustments, where applicable, will be expressed as a percentage of the Contractor's unit bid price for the hot mix within the given sub-lot.

Table 1 - Price Adjustment

| Temperature Deviation | Price Adjustment (% of Mix Price) |
|-------------------------------------|--|
| $\leq 3^{\circ}\text{C}$ | 10 % |
| $> 3 \ \& \ \leq 6^{\circ}\text{C}$ | 20 % |

.3 Disposition of Reduced / Rejected Lots

The Engineer will review the test results and determine the disposition of the mix using any PGAB product which does not conform to Table 2. Hot mix constructed using PGAB for which test results indicate that the product did not conform to specification will be dealt with as follows:

Price Reductions: As per the above table

Rejection: The Engineer reserves the right to reject all asphalt concrete mix produced with PGAB sub-lot temperature deviations exceeding 6°C from the specified minimum and maximum temperature range. Rejected sub-lots shall be removed and replaced at the Contractor's expense.

The full thickness of the appropriate lift of pavement shall be removed by cold milling. The asphalt concrete mix used to replace the rejected pavement shall meet the same requirements as those originally specified. Repair areas will be retested for acceptance with the cost of retesting to be borne by the Contractor.

5.7 Appeal Testing

The Contractor shall serve notice of appeal to the Engineer, in writing, within 48 hours of receipt of the QA test results. Appeal re-testing may be carried out on set-aside samples only if the cost of the impact of non-compliance, as determined by the Engineer, exceeds the cost of retesting.

The Contractor may have a representative present during testing at HRM's QA facility. During the period of testing, the Contractor's representative shall comment on anything concerning the testing which they do not consider to be valid, and the Engineer shall respond to all comments in order to resolve them.

The appeal testing will determine the actual performance high and low temperatures, rounded to the nearest 0.5 degrees Celsius, of the PGAB, and the outcome is binding on HRM and the Contractor.

The cost of the appeal testing, including sample delivery, shall be borne by the Contractor unless the testing confirms total conformance of the material sample to contract specifications, in which case the cost will be borne by HRM.

Table 2 – Performance Graded Asphalt Binder Specification

| Performance Grade | PG-52 | | | | | | | PG-58 | | | | | PG-64 | | | | | |
|--|-------|-----|-----|-----|-----|-----|-----|-------|-----|-----|-----|-----|-------|-----|-----|-----|-----|-----|
| | -10 | -16 | -22 | -28 | -34 | -40 | -46 | -16 | -22 | -28 | -34 | -40 | -10 | -16 | -22 | -28 | -34 | -40 |
| Average 7-day Maximum Pavement Design Temperature, °C ⁽¹⁾ | <52 | | | | | | | <58 | | | | | <64 | | | | | |
| Minimum Pavement Design Temperature, °C | >10 | >16 | >22 | >28 | >34 | >40 | >46 | >16 | >22 | >28 | >34 | >40 | >10 | >16 | >22 | >28 | >34 | >40 |
| Original Binder | | | | | | | | | | | | | | | | | | |
| Flash Point Temp., T48: Minimum °C ⁽¹⁾ | 230 | | | | | | | | | | | | | | | | | |
| Viscosity, ASTM D 4402: ⁽²⁾ Maximum, 3 Pa.s (3000cP), Test Temp., °C | 135 | | | | | | | | | | | | | | | | | |
| Dynamic Shear, TP5 ⁽³⁾ G* $\sin\delta$ ⁽⁷⁾ , Minimum, 1.00 kPa Test temperature @ 10 rad/s, °C | 52 | | | | | | | 58 | | | | | 64 | | | | | |
| Rolling Thin Film Oven (T 240) or Thin Film Oven (T 179) Residue | | | | | | | | | | | | | | | | | | |
| Mass Loss, Maximum % | 1.00 | | | | | | | | | | | | | | | | | |
| Dynamic shear, TP5: G* $\sin\delta$ ⁽⁷⁾ , Minimum, 2.20 kPa Test Temperature @ 10 rad/s, °C | 52 | | | | | | | 58 | | | | | 64 | | | | | |
| Pressure Aging Vessel Residue (PPI) | | | | | | | | | | | | | | | | | | |
| PAV Aging Temperature, °C ⁽⁴⁾ | 90 | | | | | | | 100 | | | | | 100 | | | | | |
| Dynamic shear, TP5: G* $\sin\delta$ ⁽⁷⁾ , Maximum, 5000 kPa Test Temperature @ 10 rad/s, °C | 25 | 22 | 19 | 16 | 13 | 10 | 7 | 25 | 22 | 19 | 16 | 13 | 31 | 28 | 25 | 22 | 19 | 16 |
| Physical Hardening⁽⁵⁾ | | | | | | | | | | | | | | | | | | |
| Report | | | | | | | | | | | | | | | | | | |
| Creep Stiffness, TP1 ⁽⁶⁾ S, Maximum, 300 Mpa m-value, Minimum, 0.300 Test Temp., @ 1.0 mm/min, °C | 0 | -6 | -12 | -18 | -24 | -30 | -36 | -6 | -12 | -18 | -24 | -30 | 0 | -6 | -12 | -18 | -24 | -30 |
| Direct Tension, TP3: ⁽⁶⁾ Failure strain, Minimum, 1.0% Test Temp. @ 1.0 mm/min, °C | 0 | -6 | -12 | -18 | -24 | -30 | -36 | -6 | -12 | -18 | -24 | -30 | 0 | -6 | -12 | -18 | -24 | -30 |

- (1) Pavement temperatures are estimated from air temperatures using an algorithm contained in the LTPP Bind program and may be provided by the specifying agency, or by following the procedures as outlined in MP2 and PP28.
- (2) This requirement may be waived at the discretion of the specifying agency if the supplier warrants that the asphalt binder can be adequately pumped and mixed at temperatures that meet all applicable safety standards.
- (3) For quality control of unmodified PGAB production, measurement of the viscosity of the original PGAB may be used to supplement dynamic shear measurements of G*/ $\sin\delta$ at test temperatures where the asphalt is a Newtonian fluid.
- (4) The PAV aging temperature is based on simulated climatic conditions and is one of three temperatures: 90°C, 100°C, or 110°C. The PAV aging temperature is 100°C for PG58- and above, except in desert climates, where it is 110°C.
- (5) Physical Hardening - TP1 is performed on a set of asphalt beams according to Section 13.1, except that the conditioning time is extended to 24 hrs \pm 10 minutes at 10°C above the minimum performance temperature. The 24-hour stiffness and m-value are reported for information purposes only.
- (6) If the creep stiffness is below 300 MPa, the direct tension test is not required. If the creep stiffness is between 300 and 600 Mpa, the direct tension failure strain requirement can be used in lieu of the creep stiffness requirement. The m-value requirement must be satisfied in both cases.
- (7) G*/ $\sin\delta$ = high temperature stiffness, and G* $\sin\delta$ = intermediate temperature stiffness.

INDEX TO CLAUSES

PART 1 - GENERAL

- 1.1 Work Included
- 1.2 Work Excluded
- 1.3 Related Sections
- 1.4 Codes, Bylaws, Ordinances and Regulations

PART 2 - PRODUCTS

- 2.1 Equipment

PART 3 - EXECUTION

- 3.1 General

PART 1 - GENERAL

- 1.1 Work Included .1 This section specifies the requirements for the asphaltic concrete planing and profiling. The Work consists of the furnishing of all materials, tools, equipment and labour required for the planing/profiling and removal of asphaltic concrete and Portland Cement concrete from existing roadways.
- .2 Those materials which are not specified and/or indicated but are necessary for the complete installation of the work shall be deemed the responsibility of the Contractor and shall be included at no extra cost to the Contract.
- 1.2 Work Excluded .1 Adjustment of underground appurtenance and structures.
- 1.3 Related Sections .1 S-1 Specification for Hot Mix Asphaltic Concrete.
- .2 S-2 Specification for Performance Graded Asphalt Binder.
- 1.4 Codes, Bylaws, Ordinances and, Regulations .1 All work covered by this section shall be performed according to applicable Halifax Regional Municipality Codes, bylaws, Ordinances, and Regulations.
- .2 Nova Scotia Department of Transportation and Infrastructure Renewal "Temporary Work Place Traffic Control Manual" (latest revision).
- .3 HRM Traffic Control Manual Supplement.

PART 2 - PRODUCTS

- 2.1 Equipment .1 Cold planing machine or heater planer specifically designed for automatically controlled profiling to pre-assigned depths with the following capabilities:
- Automatic controls for accurately establishing profile grades at each edge of the machine by referencing from existing pavement or an independent grade reference.
 - Capable of automatically maintaining a designed cross slope from a single reference.
 - Self propelled with sufficient power, traction, and stability to maintain an accurate depth of cut.

- Equipped with means to control dust, excessive noise, fire and/or overheating of adjacent materials (i.e. trees, grass, hedges).

PART 3 - EXECUTION

3.1 General

- .1 Location, depth, width and grade as directed by Engineer.
- .2 Locate and protect from damage any appurtenances within the site, such as manhole covers, water valves, curb and gutters, etc.
- .3 Plane pavement surface so that surface remaining has a constant and continuous cross fall, and an even texture longitudinally and transversely.
- .4 Make transverse faces at end of work period vertical. Install temporary asphalt ramps to avoid traffic hazard. Asphalt ramps are to be installed before work is completed for the day, and before the area is opened to live traffic. Asphalt ramps to be constructed to at least a 20 to 1 horizontal to vertical ratio.
- .5 Clearly mark longitudinal faces at end of work period to avoid traffic hazard. Signing in accordance with the Temporary Workplace Traffic Control Manual (latest revision).
- .6 Do not disturb appurtenances such as manhole covers, water valves, etc. during planing/profiling operations. Clearly mark appurtenances to avoid a traffic hazard after planing/profiling operations are completed. Install temporary ramps to avoid traffic hazard.
- .7 Prior to excavation around any manhole within the workplace (existing or newly constructed as part of the tender), the contractor shall supply and install catchment devices in all manholes prior to work commencing on the manhole. Such catchment devices shall be constructed and installed in a manner so as not to impede the flows through the manhole and shall be removed after all work is completed.
- .8 Remove asphaltic or Portland cement concrete which cannot be removed by planing/profiling using other methods approved by the Engineer.

- .9 Clean up site prior to shutdown at the end of each working day.
- .10 Clearly mark longitudinal faces at end of work period to avoid traffic hazard.
- .11 Paving of Arterials and Major Collectors shall take place within one week from milling, unless directed by the Engineer.
- .12 Where hardware adjustments are not made within 48 hrs. on arterial and collector roadways, temporary asphalt ramps shall be installed at a ratio of 20 to 1.

****** End S-3 ******

INDEX TO CLAUSES

PART 1 - GENERAL

- 1.1 Work Included
- 1.2 Related Sections
- 1.3 Reference Standards
- 1.4 Shop Drawings
- 1.5 Codes, Bylaws, Ordinances and Regulations
- 1.6 Certificates
- 1.7 Handling and Storage

PART 2 - PRODUCTS

- 2.1 General
- 2.2 Temporary Pavement Markings
- 2.3 Permanent Pavement Markings
- 2.4 Contact Cement

PART 3 - EXECUTION

- 3.1 General
- 3.2 Pavement Marking Drawings
- 3.3 Paint
- 3.4 Pavement Marking Tape
- 3.5 Temporary Pavement Markings
- 3.6 Arrows, Symbols and Letters

PART 1 - GENERAL

- 1.1 Work Included .1 This section specifies the requirements for the application of pavement markings. The Work consists of the furnishing of all materials, tools, equipment and labour to lay down pavement markings for the delineation and control of traffic.
- .2 Those materials which are not specified and/or indicated but are necessary for the complete installation of the work shall be deemed the responsibility of the Contractor and shall be included at no extra cost to the Contract.
- 1.2 Related Sections .1 S-1 Specification for Hot Mix Asphaltic Concrete.
- .2 S-2 Specification for Performance Graded Asphalt Binder.
- 1.3 Reference Standards .1 Manual of Uniform Traffic Control Devices for Canada (MUTCD), (5th Edition), latest revision.
- 1.4 Shop Drawings .1 Submit shop drawings in accordance with Section 01 10 00 for items listed in Supplementary Specifications.
- 1.5 Codes, Bylaws, Ordinances and Regulations .1 All work covered by this section shall be performed according to applicable Halifax Regional Municipality Codes, bylaws, Ordinances, and Regulations.
- .2 Nova Scotia Department of Transportation and Infrastructure Renewal "Temporary Work Place Traffic Control Manual" (latest revision).
- .3 HRM Traffic Control Manual Supplement.

PART 2 - PRODUCTS

- 2.1 General .1 All material supplied shall be new.
- 2.2 Temporary Pavement Markings .1 Paint: to CGSB 1-GP-71. Color to conform to CGSB 1-GP-12C, 505-308 for yellow and 513-301 for white.
- .2 Reflectorized self adhesive marking tape.
- .3 Milled surfaces shall have reflective temporary pavement marking "tabs".
- .4 Temporary markings shall be removed within 24 hours once permanent markings have been applied.

2.3 Permanent
Pavement Markings

- .1 Yellow paint: to CGSB 1-GP-71. Color to conform to CGSB 1-GP-12C, 505-308. Add 75 g/L titanium dioxide and 100 g/L lead chromate.
- .2 White paint: to CGSB 1-GP-71. Color to conform to CGSB 1-GP-12C, 513-301. Add 150 g/L titanium dioxide
- .3 Glass beads: overlay type and to CGSB 1-GP-74M, premix type to CGSB 1-GP-149M.
- .4 Marking tape: 3M Stamark 380IES or equivalent

2.4 Contact Cement

- .1 3M Stamark Surface Preparation Adhesive P-50 or equivalent.

PART 3 - EXECUTION

3.1 General

- .1 Clean pavement surface of all dirt, dust, oil, surface water and pavement markings that have been previously or poorly applied.
- .2 Thoroughly clean distributor tank before refilling with materials of different colour.
- .3 Pavement markings which are partially impacted at any intersection shall have the complete marking painted.
- .4 All incorrectly painted pavement markings are to be removed by grinding, resulting in minimal scarring and removal of at least 95% of existing markings. Markings shall be removed in such a way that the pavement surface is not damaged below a depth of 3 mm ($\frac{1}{8}$ "). Grooving, rutting or other significant damage is not acceptable. Removal equipment used for pavement marking removal shall be capable of vacuuming the debris they generate simultaneously with the grinding operation.

3.2 Pavement Marking Drawings

Where a pavement marking drawing is provided, the Contractor is required to paint markings as indicated on the drawing. Where a pavement marking drawing is not provided, the Contractor is to accurately inventory existing markings. HRM approval of the Contractor's inventory drawing is required prior to the removal of the existing pavement markings. In locations where a pavement marking drawing is not provided, the following shall apply to assist the Contractor in establishing uniformity in the development of pavement marking drawings/descriptions. This checklist should be used as a guide to ensure that all of the basic elements are covered.

For locations which require a scaled and surveyed drawing:

The contractor shall submit a pavement marking drawing that is to a 1:250 scale for signalized intersections and approaches, and a 1:500 scale on all other streets unless otherwise approved by the Engineer. Drawings shall be submitted in PDF form and printed to either an 11 x 17 or A-1 size. The pavement marking drawing shall be produced from a survey and shall inventory the existing pavement markings. The contractor shall be responsible for including any revisions as directed by HRM Traffic Management. The inventory shall include pavement markings at all intersections crossed or at the limit of streets in the contract, except for continuous center or lane lines.

The pavement marking drawing shall be submitted no later than 10 business days before scheduled removal of pavement markings and/or asphalt.

The pavement marking drawing shall include:

- Project name, street name, limits, tender number and date
- Indicate north arrow and scale
- Use a legend to define all symbols (as per HRM Red Book detail DS 13)
- Show colours, sizes and configurations of existing pavement markings (crosswalks, arrows, solid/dashed lines, hatching, bicycle symbols, etc.)
- Dimension individual lane widths, bike lane widths, length/width of hatching, stop bar setbacks, etc.
- Layout pavement markings in accordance with the HRM Red Book and the Manual of Uniform Traffic Control Devices for Canada, unless otherwise indicated.
- Pre-marking for permanent pavement markings shall be laid out by survey based on the reviewed pavement markings plan.

For locations which require a non-scaled drawing:

The contractor shall submit a pavement marking drawing, not to scale for the identified street. Drawings shall be submitted in PDF form and printed to either an 11 x 17 or A-1 size. The pavement marking drawing shall inventory the existing pavement markings and the contractor shall be responsible for including any revisions as directed by HRM Traffic Management. The inventory shall include pavement markings at all intersections crossed or at the limit of streets in the contract, except for continuous center or lane lines.

The pavement marking drawing shall be submitted no later than 10 business days before scheduled removal of pavement markings and/or asphalt.

The pavement marking drawing shall include:

- Project name, street name, limits, tender number and date
- Indicate north arrow and scale or NOT TO SCALE (N.T.S.)
- Use a legend to define all symbols (as per HRM Red Book detail DS 13)
- Show colours, sizes and configurations of existing pavement markings (crosswalks, arrows, solid/dashed lines, hatching, bicycle symbols, etc.)
- Dimension individual lane widths, bike lane widths, length/width of hatching, stop bar setbacks, etc.
- Layout pavement markings in accordance with the HRM Red Book and the Manual of Uniform Traffic Control Devices for Canada, unless otherwise indicated.

For locations which require a description:

The contractor shall submit a pavement marking description for the identified street. This pavement marking description shall inventory the existing pavement markings and the contractor shall be responsible for including any revisions as directed by HRM Traffic Management. The inventory shall include pavement markings at all intersections crossed or at the limit of streets in the contract, except for continuous center or lane lines. The pavement marking description shall include:

- Project name, street name, limits, tender number and date.
- Indicate colours, sizes and configurations of existing pavement markings (crosswalks, arrows, solid/dashed lines, hatching, bicycle symbols, etc.).
- Indicate individual lane widths, bike lane widths, length/width of hatching, stop bar setbacks, etc.

3.3 Paint

- .1 Apply paint only when air temperature is above 12 degrees Celsius and in dry weather.
- .2 Apply markings to within a tolerance of 12 mm of the dimensions indicated with a 5 mm maximum deviation in any 3.0 metre of length.
- .3 Apply paint under pressure at a rate to achieve a paint thickness of not less than 0.253 mm (10 mils) when sprayed on the surface.
- .4 Apply glass beads to all pavement markings. Apply glass beads at a rate of 300 g/m²

- .5 Protect newly painted markings from traffic by barricades or cones or other suitable method until paint has dried sufficient so as to not be damaged by traffic.
- 3.4 Marking Tape
- .1 Apply marking tape only when the air temperature, pavement temperature, and weather conditions meets or exceeds manufacturer's recommendations.
- .2 Apply markings to within a tolerance of 12 mm of the dimensions indicated with a 5 mm maximum deviation in any 3.0 metre of length.
- .3 Apply marking film into the surface of newly laid asphalt and in accordance with manufacturer's recommendations. Roll marking tape into the asphalt surface using a two-wheel or three-axle tandem roller.
- .4 Protect newly laid markings from traffic by barricades or cones or other suitable method until asphalt has cooled or markings have set sufficiently so as to not be damaged by traffic.
- 3.5 Temporary Pavement Markings
- .1 Apply temporary lane markings (tabs on milled surface, temporary tape on micro and pavement) to Arterials immediately after the placement of each lift of asphaltic concrete. Permanent markings shall be applied within 48 hours. For all other streets, apply temporary lane markings to base course of asphalt if the placement of the surface course of asphalt will not be proceeding within one week of the completion of the base course. All other streets shall have the permanent markings applied within one week after the placement of the final lift of asphaltic concrete. Pavement markings on speed humps shall be applied within 48 hours.
- .2 Apply temporary pavement markings to section 3.3 and 3.4.
- 3.6 Arrows, Symbols and Letters
- .1 Prepare templates to match patterns supplied by Owner. Obtain approval of all templates prior to use.
- Arrows to be $\frac{3}{4}$ size of Transportation Association of Canada standards listed in the Uniform Traffic Control Devices for Canada.
- .2 Apply painted arrows, symbols, and letters in accordance with section 3.3.
- .3 Arrows, symbols, and letters applied with marking tape to section 3.4.

INDEX TO CLAUSES

PART 1 - GENERAL

- 1.1 Work Included
- 1.2 Related Sections
- 1.3 Reference Standards
- 1.4 Codes, Bylaws, Ordinances and Regulations
- 1.5 Quality Control and Testing
- 1.6 Quality Assurance

PART 2 - PRODUCTS

- 2.1 General
- 2.2 Polymer Modified Emulsified Asphalt (Binder)
- 2.3 Aggregates
- 2.4 Mineral Filler
- 2.5 Water
- 2.6 Polymer Modifier
- 2.7 Additives
- 2.8 Mix Design
- 2.9 Equipment

PART 3 - EXECUTION

- 3.1 General
- 3.2 Trial Area
- 3.3 Placement/Weather Limitations
- 3.4 Notification and Traffic Control
- 3.5 Surface Preparation
- 3.6 Application
- 3.7 Temporary Pavement Markings
- 3.8 Clean Up
- 3.9 Protection of Work
- 3.10 Testing
- 3.11 Liability

PART 1 - GENERAL

1.1 Work Included

- .1 This section specifies the requirements for polymer modified micro-surfacing. The reference to micro-surfacing shall be understood to include both surface and scratch course application unless otherwise specified.
- .2 Micro-surfacing shall consist of thoroughly cleaning the existing surface, applying a homogeneous proportioned mixture of cationic polymer modified emulsified asphalt, mineral aggregate, mineral filler, water and other additives to the existing pavement surface.
- .3 Those materials which are not specified and/or indicated but are necessary for the complete installation of the work shall be deemed the responsibility of the Contractor and shall be included at no extra cost to the Contract.

1.2 Related Sections

- .1 S-1 Specification for Hot Mix Asphaltic Concrete.
- .2 S-4 Pavement Markings

1.3 Reference Standards

- .1 Uniform Traffic Control Devices for Canada, (3rd Edition), latest revision.
- .2 ASTM D2397, Standard Specification for Cationic Emulsified Asphalt
- .3 ASTM D6997, Standard Test Method for Distillation of Emulsified Asphalt
- .4 ASTM D6930, Standard Test Method for Settlement and Storage Stability of Emulsified Asphalts
- .5 ASTM D36, Standard Test Method for Softening Point of Bitumen (Ring-and-Ball Apparatus)
- .6 ASTM D2170, Standard Test Method for Kinematic Viscosity of Asphalts
- .7 ASTM C131, Standard Test Method for Resistance to Degradation of Small-Size Coarse Aggregate by Abrasion and Impact in the Los Angeles Machine
- .8 ASTM D2419, Standard Test Method for Sand Equivalent Value of Soils and Fine Aggregate
- .9 CSA A23.2-23A, Concrete materials and methods of concrete construction / Test methods and standard practices for concrete
- .10 ISSA TB-139, Classify Emulsified Asphalt/Aggregate Mixture Systems by Modified Cohesion Tester Measurement of Set and Cure Characteristics
- .11 ASTM D242, Standard Specification for Mineral Filler For Bituminous Paving Mixtures
- .12 ISSA TB-114, Wet Stripping Test for Cured Slurry Seal Mix
- .13 ISSA TB-100, Wet Track Abrasion of Slurry Surfaces

-
- | | |
|--|---|
| .14 | ISSA TB-147, Measurement of Stability and Resistance to Compaction, Vertical and Lateral Displacement of Multi-layered Fine Aggregate Cold Mixes - Method A |
| .15 | ISSA TB-109, Measurement of Excess Asphalt in Bituminous Mixtures by Use of a Loaded Wheel Tester and Sand Cushion |
| .16 | ISSA TB-113, Trial Mix Procedure for Slurry Seal Design |
| .17 | ISSA TB-144, Classification of Aggregate Filler - Bitumen Compatibility by Schulze-Breuer and Ruck Procedures |
| | |
| 1.4 Codes, Bylaws, Ordinances and Regulations | .1 All work covered by this section shall be performed according to applicable Halifax Regional Municipality Codes, bylaws, Ordinances, and Regulations. |
| | .2 Nova Scotia Department of Transportation and Infrastructure Renewal "Temporary Work Place Traffic Control Manual" (latest revision). |
| | .3 HRM Traffic Control Manual Supplement. |
| | |
| 1.5 Quality Control / Testing | .1 Quality Control testing is the responsibility of the Contractor throughout every stage of the work from and including the production of the aggregates and polymer modified asphalt emulsion to the design and placement of the final product |
| | .2 The Contractor shall provide the Engineer with a copy of all quality control test results within 24 hours of testing. |
| | |
| 1.6 Quality Assurance | .1 During the progress of the work, quality assurance testing may be conducted by the Engineer or his representative to ensure compliance with the specifications. |
| | .2 Results of the Quality Assurance testing shall be available to the Contractor. |
| | .3 Quality Assurance testing performed by the Engineer or his representative shall not be considered to be quality control testing. Sampling and testing necessary to perform quality assurance monitoring shall be at no cost to the Contractor. |
| | |
| <u>PART 2 - PRODUCTS</u> | |
| | |
| 2.1 General | .1 No recycle or other waste materials shall be permitted. |
| | |
| 2.2 Polymer Modified Emulsified Asphalt (Binder) | .1 The binder shall be a polymer modified cationic type CQS-1hP emulsion. |
| | .2 The polymer modified emulsified asphalt shall be homogeneous after mixing and show no signs of separation within 14 days of |

delivery. The addition of polymers or other additives after the manufacture of the emulsified asphalt shall not be permitted.

- .3 The emulsified asphalt shall conform to the requirements of ASTM D2397 for CQS-1hP emulsion, with the amendments listed in Table 1 below.

| Test Method | Property | Requirements |
|-------------------------|--|--------------------------------|
| ASTM D6997 | Residue by Distillation | 62% minimum |
| ASTM D6930 | Settlement and Storage Stability of Emulsified Asphalt, 24 hr. | 1% maximum |
| Tests on Residue | | |
| ASTM D36 | Softening Point | 57°C minimum |
| ASTM D2170 | Kinematic Viscosity @ 135°C | 650 mm ² /s minimum |

2.3 Aggregates

- .1 The aggregates shall consist of 100 percent crushed bedrock material, meeting the physical properties provided in Table 2 below.

| Test Method | Property | Requirements |
|--------------------|----------------------------|---------------------|
| ASTM C131* | Los Angeles Abrasion | 30% maximum |
| ASTM D2419 | Sand Equivalency | 65 minimum |
| CSA A23.2-23A | Fine Aggregate Micro-Deval | 20% maximum |

* LA Abrasion completed on parent aggregate

- .2 The aggregate gradation shall conform to the requirements for Type II and Type III M provided below in Table 3.
- .3 The aggregate stockpile shall be within the specified tolerances. The Engineer reserves the right to sample aggregate stockpiles to ensure the gradation conforms to the specifications.
- .4 Type III M modified shall be used on all streets except for low volume residential streets.

Table 3 – Aggregate Gradation

| Sieve | Type II | Type III M |
|---------|---------|------------|
| 6.7 mm | --- | 95-100 |
| 4.75 mm | 90-100 | 80-95 |
| 2.36 mm | 65-90 | 50-75 |
| 1.18 mm | 45-70 | 33-55 |
| 600 µm | 30-50 | 25-40 |
| 300 µm | 18-30 | 15-30 |
| 150 µm | 10-21 | 7-20 |
| 75 µm | 5-15 | 5-15 |

- 2.4 Mineral Filler .1 The requirement for use of mineral filler, to a maximum of 3 percent and meeting the requirements of ASTM D242, shall be determined by the mix design.
- 2.5 Water .1 The water shall be potable and shall be free of harmful salts and contaminants.
- 2.6 Polymer Modifier .1 The polymer solids shall be milled or blended into the emulsifier solution prior to the emulsification process.
- .2 The polymer modifier shall consist of a minimum of 3% polymer solids by mass of asphalt residue.
- 2.7 Additives .1 Additives may be added to the emulsion mix during construction to provide control of the quick-set properties and increase of adhesion. They shall be included in the mix design and compatible with the other components of the micro-surfacing.
- 2.8 Mix Design .1 The Contractor shall designate the mix proportions and prepare the job mix formula.
- .2 The aggregate and the polymer modified emulsified asphalt shall be assessed to confirm compatibility. The Contractor shall supply the results of the physical tests for the aggregate.
- .3 All component materials used in the mix design shall be representative of the material proposed by the Contractor for use on the contract.
- .4 The Contractor shall submit to the Engineer the final mix design and the results of the tests listed in Table 4. The material shall not be placed until the Engineer has received the mix design. The mix proportions shall be within the following limits:

| Table 4 - Micro-Surfacing Mix Properties | | |
|---|---|------------------------------------|
| | Residual Asphalt | 5.5% - 9.5% by dry mass |
| | Mineral Filler | As required |
| Test | Property | Requirements |
| ISSA TB-139 | Wet Cohesion | |
| | @ 30 minutes min. (set) | 12 kg-cm minimum |
| | @ 60 minutes min. (traffic) | 20 kg-cm minimum |
| ISSA TB-114 | Wet Stripping | Pass (90% min.) |
| ISSA TB-100 | Wet Track Abrasion Loss | |
| | One Hour Soak | 538 g/m ² maximum |
| | Six Day Soak | 807 g/m ² maximum |
| ISSA TB-147 | Lateral Displacement | 5% maximum |
| | Specific Gravity after 1,000 Cycles of 56.7 kg. | 2.1 maximum |
| ISSA TB-109 | Excess Asphalt by LWT Sand Adhesion | 538 g/m ² maximum |
| ISSA TB-113 | Mix Time @ 25°C | Controllable to 120 sec min. |
| ISSA TB-144 | Classification Compatibility | 11 Grade Points Minimum (AAA, BAA) |

- .5 The micro-surfacing shall be designed so that traffic can be allowed on the surface within one hour.

2.9 Equipment

- .1 Rotary Power Brooms shall be capable of cleaning gravel, sand, dirt and other debris from bituminous surfaces.
- .2 Mixing Equipment shall be specifically designed and manufactured to place micro-surfacing. The material shall be mixed by an automatic sequenced, self-propelled micro surfacing mixing machine, which shall be a continuous flow mixing unit, able to accurately deliver and proportion the aggregate, emulsified asphalt, mineral filler, control setting additive, and water to a revolving multi-blade double shaft mixer and discharge the mixed product on a continuous flow basis. The machine shall have sufficient storage capacity for aggregate, emulsified asphalt, mineral filler, control additive and water to maintain an adequate supply to the proportioning controls.

- .3 Proportioning Devices shall have individual volume or weight controls for proportioning each material to be added to the mix (i.e. aggregate, mineral filler, emulsified asphalt, additive, and water) shall be provided and properly marked. These proportioning devices are usually revolution counters or similar devices and are used in material calibration and determining the material output at any time.
- .4 Calibration of Proportioning Devices. Prior to beginning placement of micro-surfacing on this contract, the Proportioning Devices shall be calibrated to the satisfaction of the Engineer. The Engineer shall be notified 24 hours prior to calibration occurring. A copy of the results of the calibration must be given to the Engineer prior to any micro-surfacing operation.
- .5 Re-Calibration of Proportioning Devices. Over the duration of the work, the Proportioning Devices shall be re-calibrated, to the satisfaction of the Engineer, should the following occur:
 - .1 After every 2000 tonne of aggregate placed throughout the duration of the contract.
 - .2 A change in the source of aggregate from that used in the previous calibration.
 - .3 Mechanical failure to the application system and/or Proportioning Devices in which repair is required.
- .6 Spreading Equipment shall be used to apply the mixture. The mixture shall be spread uniformly by means of a conventional augured surfacing spreader box attached to the mixing machine and equipped with paddles to agitate and spread the material evenly throughout the box. A front seal shall be provided to ensure no loss of the mixture at the pavement contact point. The rear seal shall act as final strike-off and shall be adjustable. The spreader box and rear strike-off shall be so designed and operated that a uniform consistency is achieved to produce a free flow of material to the rear strike-off. The spreader box shall have suitable means provided to manoeuvre the box to compensate for variations in the pavement geometry. The rut filling spreader box shall be specifically designed for rut filling applications. Rear strike-off bar shall be one piece of rigid steel or metal (scratch course only).

PART 3 - EXECUTION

3.1 General

- .1 Location and dimensions as indicated on drawings or as directed by Engineer.

- 3.2 Trial Area .1 The Contractor shall place a trial area 100 m in length for the commencement of the micro-surfacing operation, one lane width, to demonstrate the ability to produce micro-surfacing in conformance with this specification. The trial area shall be accepted after inspection by the Engineer after 1 hour. The Contractor shall remove and replace any damaged or unsatisfactory micro-surfacing at no cost to the Municipality. The location of the trial area shall be approved by the Engineer.
- 3.3 Placement/
Weather Limitations .1 Micro-surfacing work shall only be completed between June 1st and September 1st. In addition, the micro-surfacing shall not be applied if either the pavement or air temperature is below 50°F (10°C) and falling but may be applied when both pavement and air temperature are above 45°F (7°C) and rising. No micro-surfacing shall be applied when there is danger that the finished product will freeze before 24 hours. The mixture shall not be applied when weather conditions prolong opening to traffic beyond a reasonable time.
- 3.4 Notification and
Traffic Control .1 The Contractor shall notify homeowners and businesses affected by the construction at least one day in advance of the surfacing. Should work not occur on the specified day, a new notification shall be distributed. The notification shall be in the form of a written posting, stating the time and date that the surfacing will take place. If necessary, signage alerting traffic to the intended project shall be posted.
- .2 The Contractor is responsible for providing traffic control required to protect the work zone and to ensure the safe passage of traffic in conformance with the Nova Scotia Department of Transportation and Infrastructure Renewal “Temporary Work Place Traffic Control Manual” (latest revision), the HRM Traffic Control Manual Supplement and as directed by the Engineer.
- 3.5 Surface
Preparation .1 Immediately prior to applying the micro-surfacing, the area to be surfaced shall be thoroughly cleaned of all vegetation, loose material, sand, dirt and other debris. Dried mud or other foreign matter, which cannot be removed with the rotary power broom, shall be removed by hand blade or other approved method. Water, if required, shall be applied to pre-wet the surface immediately ahead of the spreader at a rate to dampen the surface without allowing any freestanding or free flowing water. If water is used, cracks shall be allowed to dry thoroughly before applying micro-surfacing. Manholes, valve boxes, drop inlets and other service entrances shall be protected from the micro-surfacing by a suitable method. Tack coat shall be applied at a rate of 0.30 l/m².
- 3.6 Application .1 The mixture shall be spread to fill minor cracks and shallow potholes and leave a uniform surface. The application shall consist of a minimum of a scratch coat and a final coat with combined minimum rate of application of 18 kg/m².

- .2 A sufficient amount of surface sealer shall be carried in all parts of the spreader box at all times so that complete coverage is obtained. Spraying of additional water into the spreader box shall not be permitted.
- Overloading of the spreader box shall be avoided. No lumping, balling, or unmixed aggregate shall be permitted in the finished surface. No dry aggregate, either spilled from the lay-down machine or existing on the road, shall be permitted. Any oversized aggregate or foreign materials shall be screened from the aggregate prior to delivery to the mixing machine.
- .3 Handwork. In restricted areas where hand spreading is necessary, slight adjustments to the mix formula may be used to retard the setting time. The mixture shall be poured into a small windrow along one edge of the surface to be covered. The mixture shall be spread uniformly with squeegees or other suitable hand tools. As much as possible, handwork shall exhibit the same finish as that applied by the spreader box. All handwork shall be completed prior to final surfacing.
- .4 Appearance as follows:
- .1 The finished micro-surfacing shall have a uniform texture free from excessive scratch marks, tears or other surface irregularities. Tear marks in any 12 m² per lane are considered excessive if there are: 1) four or more marks 12 mm wide or wider and 100 mm or more long; or 2) any marks 25 mm wide or wider and 25 mm or more long.
 - .2 There shall be no longitudinal ripples (raking) or wash-boarding (chatter), 7.5 mm deep, as measured with a 3 metre straight edge or other irregularities that will affect the ride quality.
 - .3 The edges of the micro-surfacing for surface application shall be uniform with neat appearance along the roadway centerline, lane lines, shoulder, pavement edge, and curb lines.
- .5 Joints as follows:
- .1 The longitudinal and transverse joints shall be neat and uniform in appearance. No excessive buildup, uncovered areas, non-homogeneous mixture or unsightly appearance shall be permitted on longitudinal or transverse joints.
 - .2 The longitudinal joints in the scratch course shall be constructed as a butt joint. The longitudinal joints in the surface course shall be placed on lane lines with less than 100 mm overlap on adjacent passes.
 - .3 Transverse joints shall be constructed with no more than 6 mm difference in elevation across the joint as measured with a 3 m straight edge.
 - .4 Rolling. The micro-surfacing shall be rolled unless otherwise directed by the Engineer.

- .6 Mixture as follows:
- .1 The micro-surfacing shall possess sufficient stability so that premature breaking of the material in the spreader box does not occur. The mixture shall be homogeneous during and following mixing and spreading. It shall be free of excess liquids which create segregation of the aggregate. Spraying of additional water into the spreader box shall not be permitted.
- .7 Defects as follows:
Defects in finished surface shall include but are not necessarily limited to the following:
- Total ruts > 6 mm deep, as measured with a 3-metre straight edge, exceeding 2% base on 10 random samples per lane-km.
 - Total areas exhibiting raking and chatter exceeding 2% in any 100 m² area.
 - Bleeding and flushing exceeding 2% in any 100 m² area.
 - Bleeding and/or flushing at joints

Any 400 metre lane segment with repairs or defects exceeding 5% of the area shall require re-application of micro-surfacing over the entire segment.

All work for reconstruction of unacceptable areas shall be at the Contractor's expense.

Any part of completed micro-surfacing rejected for surface defects shall be repaired within 20 days from the time the Contractor receives notification of rejection, but in no case later than August 31st of the current year.

If the 20day period extends past August 31st of the current year, the Contractor shall complete the repairs between June 1st and June 16th of the following year. All defects shall be repaired using micro-surfacing (this includes any repairs within the two-year warranty).

The Contractor shall guarantee the Work against failure and defects, and shall hold the Owner blameless in all claims arising from the Work, any of which results from factors including, but not limited to poor workmanship, poor or incompatible materials, improper design of application rates, inadequate traffic control, and/or failing to practice proven micro-surfacing procedures.

Generally, areas of delamination and flushing or bleeding surfaces shall be construed as failure; however, the Engineer shall be the sole judge as to the areas that must be re-treated.

- 3.7 Temporary Pavement Markings .1 Once the micro-surfacing application is capable of supporting traffic, temporary pavement markings shall be installed immediately.
- 3.8 Clean Up .1 All areas, such as shoulders and gutters, shall have the micro-surfacing mix removed as specified by the Engineer. The Contractor shall, on a daily basis, remove any debris associated with the performance of the work.
- .2 After completion of the micro-surfacing, all areas such as gutters and adjacent asphalt surfaces, shall be thoroughly cleaned of all loose material, sand, dirt and other debris.
- .3 All hardware to be removed from site daily.
- 3.9 Protection of Work .1 The Contractor shall be responsible for ensuring that the mixture is not damaged by traffic.
- .2 Traffic, including construction traffic, shall be kept off the freshly placed mixture for whatever time is required to prevent damage to the surface and until premarking of traffic lines with paint is complete.
- 3.10 Testing .1 Straight Edges. A 3 m straight edge may be used to check for cross fall at the discretion of the Engineer.
- .2 Stringline. A stringline or other device may be required to ensure the longitudinal edges are straight and meet the existing pavement edge or as directed by the Engineer.
- 3.11 Liability .1 During the period of construction and the two year maintenance period the Contractor shall be responsible for processing any and all claims for property damage and/or bodily injury caused by failure of the Micro-Surfacing including but not limited to motor vehicle or pedestrians. The contractor shall be responsible for the payment of all property damage and bodily injury claims and agrees to save and holds harmless Halifax Regional Municipality from all such claims.

**** End S-5 ****

HALIFAX REGIONAL MUNICIPALITY
TRAFFIC CONTROL MANUAL SUPPLEMENT

HALIFAX REGIONAL MUNICIPALITY
TRAFFIC CONTROL MANUAL SUPPLEMENT

The following provisions shall apply to all contractors/organizations and others doing work on streets under the jurisdiction of the Halifax Regional Municipality. These provisions are in addition to the “Nova Scotia Temporary Workplace Traffic Control Manual”, latest edition, (occasionally referred to in this document as the MANUAL) published by the Nova Scotia Department of Transportation & Infrastructure Renewal.

For the purposes of this document, "Engineer" means the Engineer of the Halifax Regional Municipality and includes a person acting under the supervision and direction of the Engineer. The Traffic Authority shall be the Traffic Authority or Deputy Traffic Authority of the Municipality; as appointed by Administrative Order 12, as amended from time to time. All other definitions shall be consistent with those provided in the Nova Scotia Temporary Workplace Traffic Control Manual, latest edition (MANUAL).

NEW FOR 2024

The following is a list of significant changes in this document compared to the version published in January 2023.

2024

General Changes

Significant changes from previous versions highlighted in text using the year graphic in the left margin. Minor changes will not be specifically called out.

Part I – General

6. Minimum Lane Widths

- Changes in minimum lane width.

Part II – Additional provisions

7. Roundabouts

- Section removed.

12. Identification of Traffic control signage

- Part of the section removed.

Part III – Closures

13.4 Street Closures

- Minor text edits.

14. Closure Notifications

- Minor edits.

Schedule A – List of Restricted Streets

- Barrington Street – Cornwallis Street changed to Nora Bernard Street
Nora Bernard Street – Name changed from Cornwallis Street to Nora Bernard Street
- Dunbrack Street – North West Arm Drive changed to Main Street
- Hammonds Plains Road – Segment adjusted
- Highway 7 – Segment expanded to account for 2022 boundary update
- Lawrencetown Road – Included to account for 2022 boundary update
- St. Margarets Bay Road – Segment expanded to account for 2022 boundary update

TABLE OF CONTENTS

PART I - GENERAL

- 1 BYLAWS AND ORDINANCES
- 2 PRECONSTRUCTION MEETINGS
- 3 PERMITS

PART II – ADDITIONAL PROVISIONS

- 4 TRAFFIC AUTHORITY APPROVALS
- 5 TRAFFIC AUTHORITY CONSULATION
- 6 MINIMUM LANE WIDTHS
- 7 ROUNDABOUTS
- 8 ADVANCE WARNING SIGNS
- 9 PARKING RESTRICTIONS
- 10 CONSTRUCTION MANAGEMENT PLANS
- 11 IMPACTS TO TRANSIT ROUTES AND STOPS
- 12 IDENTIFICATION OF TRAFFIC CONTROL SIGNAGE

PART III - CLOSURES

- 13 CLOSURES
 - 13.1 SIDEWALK CLOSURES
 - 13.2 BICYCLE LANE CLOSURES
 - 13.3 TRANSIT LANE CLOSURES
 - 13.4 STREET CLOSURES
- 14 CLOSURE NOTIFICATIONS

PART IV – DISRUPTION MANAGEMENT

- 15 MINIMUM NUMBER OF LANES
- 16 HOURS OF WORK
- 17 EXEMPTIONS AND EXCEPTIONS
 - 17.1 VERY SHORT DURATION WORK
- 18 SIGNALIZED INTERSECTIONS

SCHEDULE A – List of Restricted Streets

SCHEDULE B – List of Holiday Exemptions to Restricted Streets

SCHEDULE C – Document Version Control

PART I - GENERAL

1 BYLAWS AND ORDINANCES

It is the responsibility of every contractor, owner or organization doing work in Halifax Regional Municipality to be familiar with Provincial laws and with By-laws, Administrative Orders, Regulations and Ordinances of the Halifax Regional Municipality. This includes but is not limited to the Streets By-law, the Noise By-law, the Truck Routes By-law and the Administrative Order Respecting Construction Site Management. Failure to comply with any legislation or regulation may result in penalties.

2 PRECONSTRUCTION MEETINGS

For any work where the requirement for a pre-construction meeting is not already addressed as a condition of a tender or permit; where a planned project for which the work area is located on any street appearing on the list in Schedule A, as well as for any Halifax Transit routes and truck routes, HRM may require a preconstruction meeting to discuss the scope of work. Stakeholders invited to attend may include (but is not limited to) the owner/developer, contractor(s), inspector(s), Transit, Utilities, Traffic Management, Development Approvals.

3 PERMITS

With the exception of emergency situations, no work may commence on any HRM street without first obtaining a permit as required by the provisions of the HRM Street By-Law (S-300). Permit applications must be submitted at least 5 business days before the proposed construction start date. Construction must not start before the permit is issued.

PART II – ADDITIONAL PROVISIONS

4 TRAFFIC AUTHORITY APPROVALS

As per the requirements of the MANUAL, the following traffic control conditions are not permitted without authorization of the Traffic Authority:

| Description | Corresponding MANUAL Section |
|--|------------------------------|
| Partial Lane closures on multi-lane roads | 7.0 |
| Altered centerline on Highway (road with speed limit > 50 km/h) | 7.0 |
| Altered Centrelines on multi-lane roads when lane widths are being reduced | 7.0 |
| Speed Zone Restrictions, meaning any speed limit reductions | 8.3 + 13.3 |
| Installation of permanent Stop signs | 8.4 |
| Extending work areas where pilot vehicles are used beyond 2km | 9.4 |
| Temporary Traffic Control Signals | 9.6 |
| As noted in various Application Guides A, B and C | |

In addition, if the Traffic Authority is to authorize the above noted conditions, the Traffic Control Plan must have a space for the Traffic Authority's signature and date as well as identify why the Traffic Authority is signing the document.

Example:

| | |
|--|------------|
| Approved by _____ Traffic Authority | _____ Date |
|--|------------|

For the approval of (insert reason here, e.g.: the altered centreline) only. All other aspects of this Temporary Traffic Control Plan must follow the Temporary Traffic Control Manual, latest edition.

5 TRAFFIC AUTHORITY CONSULTATION

As per the requirements of the MANUAL additional consultation is required before disabling, covering or removing any permanent regulatory, warning signs, traffic signals, beacons or pavement markings (Section 4) and before establishing a detour Application Guides A77, B77 and C77, C114, C119, and C139).

6 MINIMUM LANE WIDTHS

Notwithstanding the requirements of the MANUAL, the minimum width of any narrowed lane shall be 3.0 metres. Where the lanes are delineated by painted lines, the minimum lane width shall be 3.5 metres.

Notwithstanding, the Engineer may require lane widths wider than the minimums stated above in order to ensure safe traffic conditions.

7 ROUNDABOUTS

[REMOVED. See the “D” Application Guides for Roundabouts in the MANUAL]

8 ADVANCE WARNING SIGNS

HRM may require advance warning signs for any construction project which is expected to cause major delays or affect a large number of road users. Any time advanced warnings are used to complement a traffic control setup, a plan must be provided to HRM for review prior to construction. The submission must include the location of the advance warning, the proposed type of advance warning (electronic variable message signs, static text signs, etc.) and the proposed message. HRM may require the message to be modified at any time.

Portable Electronic Variable Message Sign usage is to be consistent with Nova Scotia Public Works Policy PO1028 – Use of Portable Variable Message Signs.

9 PARKING RESTRICTIONS

The contractor shall make every attempt to prevent parking in the construction zone by using cones or barrels to reserve curb space required for construction activities. Posting regulatory signage for the purposes of restricting parking for construction activities will only be considered in exceptional circumstances. Requests for temporary regulatory signage must be submitted a minimum of 10 business days in advance of construction.

Contractors may install their own non-regulatory signs to restrict parking. They must be text only and resemble a construction sign, with black letters on an orange background. Any non-regulatory signs must not cover any existing signs (including but not limited to other regulatory signage used to control parking). They are not enforceable through HRM Parking Enforcement but may prove helpful in protecting space ahead of planned works. These signs should be installed 24 hours in advance of construction for maximum effectiveness.

10 CONSTRUCTION MANAGEMENT PLANS

Construction Management Plans (CMP, formerly called traffic control and pedestrian management plans, or TCP and PMP respectively) must be submitted for every project. The CMP must be prepared in accordance with applicable regulatory requirements and must include the contact information for the qualified Temporary Workplace Signer (TWS) who created it.

Plans must include information about how each types of road user - pedestrians, cyclists, and motor vehicles – will be accommodated past the work area.

Particular attention to detail is necessary for pedestrian impacts along a Transit route where the work area includes a bus stop that will remain open; the plans must include comments on how access will be maintained to the Transit stop. Special consideration should also be made for pedestrian access for work areas within Business Improvement Districts, School Zones, and other locations significant when pedestrian volume is expected.

Pedestrian management plan shall consider pedestrians of all abilities, including but not limited to those using mobility aids such as canes, walkers, wheelchairs.

PART II – ADDITIONAL PROVISIONS

The CMP must include a detailed diagram and signature block whenever Traffic Authority approval or consultation is required (see Sections 4 and 5 of this document). Otherwise, the format of the CMP will depend on the complexity of the traffic control setups, and information may be conveyed through an appropriate combination of text and/or diagrams.

HRM reserves the right to request additional detail or information prior to issuing a Streets and Services Permit.

11 IMPACTS TO TRANSIT ROUTES AND STOPS

Every effort should be made to maintain transit accessibility along designated Halifax Transit routes and at stops. If work will impact Halifax Transit routes or stops, a minimum of 5 business days notice is required to schedule work.

Halifax Transit bus stops may remain open near work areas under the following circumstances:

- The curbside lane of the travel way remains open and accessible for buses. A minimum of 40 m of curb space preceding the bus stop sign is required.
- The sidewalk or shoulder adjacent to the street remains open and accessible for pedestrians. If sidewalk and bus pad at the bus stop will be temporarily reinstated with gravel then the stop is still considered open but no longer considered accessible. Halifax Transit must be notified 5 days in advance when the accessibility status of a bus stop is changed due to construction activity.

If the above criteria cannot be met, the bus stop must be closed. The intention to close the bus stop must be clearly indicated on the CMP when making the application for Streets and Services Permit.

12 IDENTIFICATION OF TRAFFIC CONTROL SIGNAGE

[REMOVED. See Section 8 Temporary Condition Signs – Urban Signs]

[REMOVED. See Section 13.3 Operational Requirements and Standards, Rule 1.17 Urban Signs]

Traffic control signage that is placed within the HRM Street right of Way must include the owner's name or logo in a format that is compliant with *Section 9 – Temporary Condition Devices – Company Name or Logo* so that the owner of the sign can be immediately identified.

PART III – CLOSURES

13 CLOSURES

The Integrated Mobility Plan was unanimously approved by Halifax Regional Council on December 5, 2017. Objective 2.3.1 of the Plan is to “*Meet the needs of all ages, abilities and travel modes in the design and maintenance of streets*”. Construction Management Plans that must also consider the needs and travel modes of all road users when construction activities close critical parts of the street.

13.1 Sidewalk Closures

Sidewalk closures should be avoided wherever possible, and the Engineer must grant approval before a sidewalk¹ can be closed. A request for a sidewalk closure must be accompanied by a CMP that describes the proposed detour route. Pedestrians should be directed to the other side of the street at marked crosswalks, where possible.

13.2 Bicycle Lane Closures

The MANUAL addresses procedures for closing bicycle lanes. In HRM, the MANUAL processes are appropriate for closing painted bicycle lanes (unprotected bicycle lanes) only. Unless otherwise approved by the Engineer, protected bicycle lanes and other components of an “All Ages and Abilities” (AAA) bicycle network that are closed or adversely affected by construction should be provided a facility which provides reasonably similar protection, and this must be provided as part of the CMP. Short Duration Work and works done under an Annual Permit are exempt from the requirement to provide reasonably similar protection, and instead must comply with the requirements of the MANUAL. The Engineer must grant approval for any exceptions.

13.3 Transit Lane Closures

Work affecting Transit Lanes shall be restricted to non-operational hours (meaning hours that the lane is not dedicated to Transit vehicles only). The Engineer must grant approval for any exceptions. Exceptions shall be requested through the CMP.

13.4 Street Closures

The Engineer must grant approval before a street can be closed. Any request for a construction related street closure must be complete and include the following:

- Purpose of closure
- Date and duration of planned closure, as well as rain dates or backup dates if known
- Location of work site
- Limits of planned closure
- Detour plan(s):
 - Pedestrian and Vehicle detours, as well as separate Bicycle, Transit, Passenger, and Truck Detours if they are different than the standard vehicle detour
- Copy of closure notification letter to be distributed to the affected residents
- Contact information for the person or company responsible for the closure

¹ For the purposes of this document, only an improved area – asphalt or concrete – between the travelled way and the edge of the right of way shall be considered a sidewalk. This is **not** consistent with the definition of a sidewalk in the Nova Scotia Motor Vehicle Act.

PART III – CLOSURES

Prior to closing a street, an applicant must have a plan to prevent disruptions in services such as solid waste removal, Halifax Transit, Canada Post community mailbox access and snow clearing activities when applicable. The Traffic Authority may dictate additional requirements regarding detour signage as their sole discretion.

14 CLOSURE NOTIFICATIONS

For all planned construction related street closures, the contractor is responsible to distribute notification to all affected property owners/business owner/tenants regarding the planned disruption. A closure must be approved by the Engineer prior to notice delivery and be hand delivered to all property owners or businesses within the closed area. These notices must contain the following:

- the name of the person(s) responsible for the closure, including a contact person and telephone number (contact person(s) must be available throughout the duration of the closure);
- the intended date and time the closure or disruption will commence;
- the expected duration of the closure or disruption; and
- the location of the closure or disruption and affected area.

Notices must be delivered at least 5 business days in advance of any street closure. After the initial hand-delivered notification, the contractor must provide confirmation to HRM that the notices were delivered, including a list of all the civic addresses included in the distribution. In addition to the notification process above, HRM shall issue a Public Service Announcement in advance of the closure of any street on the list found in Schedule A.

When multiple or repeated street closures on the same project are required, notification must follow the above process, and also include the expected number of closures and schedule in the notice. Subsequent notification for closures on the same project must be provided to affected residents a minimum of 48 hours in advance of the closure.

PART IV – DISRUPTION MANAGEMENT

15 MINIMUM NUMBER OF LANES

In most cases, activities in the Street may reduce the travelled way to one lane of vehicular traffic, supporting two-way traffic where it normally exists. On certain streets, reducing the travelled way to one lane must be avoided due to the significant delays it would cause. Additional restrictions may be imposed on any work within the HRM Street by permit condition. The following conditions regarding lane reductions shall apply unless otherwise specified on the Streets and Services permit according to the table in Schedule A (attached).

- Maintain two lanes during Peak Hours: In this case, at least two lanes (one in each direction) must be maintained during Peak Hours. If this condition is met, work may continue through the Peak Hours. If this condition cannot be met, normal Peak Hour Restrictions apply. Peak Hours shall be defined as being from 7:00 a.m. to 9:00 a.m. and 4:00 p.m. to 6:00 p.m. from Monday to Friday, Holidays excluded. Holidays are identified in Schedule B (attached).
- Maintain two lanes at all times: In this case, at least two lanes (one in each direction) must be maintained at all times. “Stop and Go” traffic is permitted by exception only. This condition may be used in addition to other restrictions.

Failure to respect restrictions on the permit concerning minimum number of lanes may result in penalties in accordance with the HRM Street By-law (S-300).

16 HOURS OF WORK

Hours of work shall be restricted in accordance with the provisions of the HRM Noise By-law (N-200). Additional restrictions may be imposed on any work within the HRM Street by permit condition. The following restrictions regarding hours of work shall apply, unless otherwise specified on the Streets and Services permit, according to the table in Schedule A (attached).

- PM PHR (Peak Hour Restrictions) Only: In this case, no on street work² may proceed during the PM Peak Hours. PM Peak Hours shall be defined as being from either 4:00 p.m. to 6:00 p.m. from Monday to Friday. Holidays excluded. Holidays are identified in Schedule B (attached).
- PHR (Peak Hour Restrictions) apply only in Peak Direction: In this case, work may proceed if the capacity in the peak direction is not compromised; typically on a multi-lane street. For example, if there are two lanes in each direction, work may proceed in the morning peak if both inbound lanes are open and one outbound lane is also open.
- Peak Hour Restricted: In this case, no on street work² may proceed during Peak Hours. Peak Hours shall be defined as being from 7:00 a.m. to 9:00 a.m. and from 4:00 p.m. to 6:00 p.m. from Monday to Friday, Holidays excluded and from 2:00 p.m. to 6:00 p.m. on the day in advance of the July 1 long weekend (if applicable) and the Friday in advance of Natal Day and Labour Day long weekend. Holidays are identified in Schedule B (attached).
- Evening and Weekend Only: In this case, no on street work² may proceed between the hours of 7:00 a.m. and 6:00 p.m. from Monday to Friday, Holidays excluded. Holidays are identified in Schedule B (attached). Work must either take place over night or on a Saturday

² References to “on street work” include the entire right of way width; not just the travelled way or traffic lanes.

PART IV – DISRUPTION MANAGEMENT

or Sunday. Provisions of the HRM Noise By-law shall apply. Some work may require an exemption from Regional Council to satisfy certain Noise By-law provisions.

Note that when a temporary workplace encompasses multiple streets the most stringent restrictions apply. Failure to respect hour of work restrictions on the permit may result in penalties in accordance with the HRM Street By-law (S-300).

17 EXEMPTIONS AND EXCEPTIONS

Exceptions to these restrictions will be considered on a case by case basis only when specifically requested by the permit applicant and/or contractor. The two main criteria for evaluating the exception request will be (1) what the actual impact of the work area will be on the public and (2) whether the scope of work and excavation size prevents the work area from being re-opened to traffic in accordance to the applicable restricted times noted above. Any exception to the hours of work restrictions will be reflected on the permit.

Permission to work through restricted times may be granted by the Engineer or the HRM Inspector, only in the event of unforeseen circumstances which make re-opening the work area to traffic impractical. All requests to continue work through restricted hours must be requested in writing at least one hour before the restriction is to take effect. Permission is only considered granted upon receipt of a response in writing from the Engineer or the HRM Inspector indicating the request is approved. A Public Service Announcement will be issued by HRM advising motorists of the continuing works.

17.1 VERY SHORT DURATION WORK

Very Short Duration Work – defined in the MANUAL as work at a location that does not take more than 30 minutes excluding the time required to set-up and take-down traffic control equipment – will generally be exempt from “Evening and Weekend Only” restrictions provided Peak Hour Restrictions are respected.

18 SIGNALIZED INTERSECTIONS

On a case by case basis, HRM may impose stricter hours of work restrictions after reviewing traffic control plans if a project requires traffic signals to be shut off. In any case that traffic signals are to be shut off additional traffic control persons must be available to assist pedestrians to ensure safe crossings. Stricter hours of work may also be imposed for sections of work near traffic signals when the setup would force unreasonable delays at the signals.

SCHEDULE A - List of Restricted Streets

| Street Name | Segment | | Minimum Number of Lanes | | Hours of Work | | | |
|-----------------------------|---|------------------------------|--------------------------------------|---------------------------------|---------------|----------------------------------|----------------------|--------------------------|
| | From | To | Maintain two lanes during Peak Hours | Maintain two lanes at all times | PM PHR only | PHR apply only in Peak Direction | Peak Hour Restricted | Evening and Weekend Only |
| Agricola Street | Cunard Street | Duffus Street | | | | | X | |
| Ahern Avenue | Cogswell Street | Bell Road | | | | | X | |
| Akerley Boulevard | Windmill Road | John Savage Avenue | | X | | | X | |
| Albemarle Street | Cogswell Street | Duke Street | | | | | X | |
| Albro Lake Road | Victoria Road | Windmill Road | | | | | X | |
| Alderney Drive | Windmill Road | Prince Albert Road | | X | | | X | |
| Alma Crescent | Titus Street | Supreme Court | | X | | | X | |
| Almon Street | Connaught Avenue | Gottingen Street | | | | | X | |
| Armdale Roundabout | All circulating lanes, including all approach and exit lanes - see Section 6 of this document | | | | | | | X |
| Atlantic Street (Dartmouth) | Pleasant Street | Transit Terminal – civic 9 | | | | | X | |
| Baker Drive | Portland Street | Norm Newman Drive | | X | | | X | |
| | Norm Newman Drive | Mount Hope Avenue | | | | | X | |
| Barrington Street | MacKay Bridge Ramp | Duffus Street | | | | | | X |
| | Duffus Street | Nora Bernard Street | | | | | X | |
| | Duke Street | Spring Garden Road | | | | | | X |
| | Spring Garden Road | Inglis Street | | | | | X | |
| Basinview Drive (Bedford) | Hammonds Plains Road | Meadowbrook Drive | | | | | X | |
| Bayers Road | Connaught Avenue | Windsor Street | | X | | | X | |
| | Highway 102 | Connaught Avenue | | X | | | | X |
| | Joseph Howe Drive | Highway 102 | | X | | X | | |
| Bayview Road | Bedford Highway | Lacewood Drive | | | | | X | |
| Beaver Bank Road | Earl Gordon Drive | Sackville Drive | | | | | X | |
| Bedford Highway | Hwy 102 | Moirs Mills Road | | X | | | X | |
| | Moirs Mills Road | Kearney Lake Road | | | | | | X |
| | Kearney Lake Road | Flamingo Drive | | X | | | X | |
| | Flamingo Drive | Sherbrooke Drive | | X | | | | X |
| | Sherbrooke Drive | Traffic Signals at Civic #50 | | X | | | X | |
| | Traffic Signals at Civic #50 | Windsor Street | | | | | | X |
| Bell Road | Robie Street | Sackville Street | | | | | X | |
| Bissett Road | Cole Harbour Road | Cow Bay Road | | | | | X | |
| Bluewater Road | Hammonds Plains Road | Larry Uteck Boulevard | | X | | | | |
| Boland Road | Victoria Road | Wyse Road | | | | | X | |
| Braemar Drive | Waverley Road | Grahams Grove | | | | | X | |
| Brunswick Street | Cogswell Street | Spring Garden Road | | | | | X | |
| Burnside Drive | Akerley Drive | Hwy 111 | | X | | | X | |
| Caldwell Road | Cole Harbour Road | Shore Road | | | | | X | |
| Caledonia Road | Main Street | Montebello Drive | | X | | | | |
| Chain Lake Drive | Lacewood Drive | Otter Lake Court | | X | X | | | |
| | Otter Lake Court | Horseshoe Lake Drive | | X | | | | |
| Chebucto Road | Armdale Rotary | Mumford Road | | X | | | | X |
| | Mumford Road | North Street | | X | | | X | |
| | North Street | Windsor Street | | | | | X | |
| Cobequid Road | Sackville Drive | Nelson Drive | | X | | | X | |
| | Nelson Drive | Rocky Lake Drive | | | | | X | |
| Coburg Road | Oxford Street | Robie Street | | | | | X | |
| Cogswell Street | Robie Street | North Park Street | | X | | | | |
| | North Park Street | Brunswick Street | | | | | X | |
| Cole Harbour Road | Portland Street | Bissett Road | | X | | X | | |
| | Bissett Road | Ross Road | | | | | X | |
| Commodore Drive | Burnside Drive | Eileen Stubbs Drive | | X | | | | X |
| | Eileen Stubbs Drive | Highway 118 Ramp | | X | | | X | |
| Connaught Avenue | Windsor Street | Jubilee Road | | X | | X | | |
| Nora Bernard Street | North Park Street | Barrington Street | | | | | X | |
| Countryview Drive | Wright Avenue | Commodore Drive | | X | X | | | |
| Cow Bay Road | Main Road | Dyke Road (west) | | | | | X | |
| Cowie Hill Road | Herring Cove Road | Cowie Hill Connector | | | | | X | |
| Crichton Avenue | Glen Manor Drive | Ochterloney Street | | | | | X | |
| Cumberland Drive | Cole Harbour Road | Colby Drive | | X | | | | |
| Cunard Street | Windsor Street | Gottingen Street | | | | | X | |
| Dartmouth Road | Bedford Highway | Magazine Hill (Highway 7) | | X | | | X | |
| Dentith Road | Old Sambro Road | Herring Cove Road | | X | | | | |
| Devonshire Avenue | Novalea Drive | Barrington Street | | | | | X | |
| Duffus Street | Robie Street | Novalea Drive | | | | | X | |

| Street Name | Segment | | Minimum Number of Lanes | | Hours of Work | | | |
|-----------------------|------------------------|------------------------|--------------------------------------|---------------------------------|---------------|----------------------------------|----------------------|--------------------------|
| | From | To | Maintain two lanes during Peak Hours | Maintain two lanes at all times | PM PHR only | PHR apply only in Peak Direction | Peak Hour Restricted | Evening and Weekend Only |
| Duke Street (Bedford) | Glendale Avenue | Rocky Lake Drive | | X | | | | |
| Duke Street (Halifax) | Brunswick Street | Hollis Street | | X | | | X | |
| | Hollis Street | Upper Water Street | | | | | | X |
| Dunbrack Street | Kearney Lake Road | Main Street | | X | | | X | |
| Dutch Village Road | Joseph Howe Drive | Joseph Howe Drive | | | | | X | |
| Dyke Road | Cow Bay Road | Cow Bay Road | | | | | X | |
| Eisener Boulevard | Portland Street | Norm Newman Drive | | X | | | X | |
| | Norm Newman Drive | Portland Hills Drive | | X | | | | |
| Fall River Road | Windsor Junction Road | Highway 2 | | | | | X | |
| Farnham Gate Road | Parkland Drive | Dunbrack Street | | X | | | | |
| Finlay Drive | Commodore Drive | Wright Avenue | | X | | | | |
| First Lake Drive | Metropolitan Avenue | Cobequid Road | | | | | X | |
| Flamingo Drive | Knightsridge Drive | Bedford Highway | | | | | X | |
| Forest Hills Parkway | Main Street | Circassion Drive | | | | | X | |
| | Circassion Drive | Cole Harbour Road | | X | | | X | |
| Gary Martin Drive | Hammonds Plains Road | Broad Street | | | | | X | |
| George Street | Barrington Street | Lower Water Street | | | | | X | |
| Glen Manor Drive | Crichton Avenue | Mic Mac Boulevard | | X | | | X | |
| Glendale Avenue | Cobequid Road | Duke Street (Bedford) | | X | | | X | |
| Glendale Drive | Beaverbank Road | Cobequid Road | | | | | X | |
| Gordon Avenue | Main Street | Hwy 111 | | | | | X | |
| Gottingen Street | Young Street | Black Street | | | | | X | |
| | Black Street | Cogswell Street | | | | | | X |
| | Cogswell Street | Brunswick Street | | X | | | | |
| Grahams Grove | Highway 111 | Prince Albert Road | | | | | X | |
| Hammonds Plains Road | St. Margarets Bay Road | Gary Martin Drive | | | | | X | |
| | Gary Martin Drive | Hwy 102 | | X | | | X | |
| | Hwy 102 | Bedford Highway | | | | | | X |
| Hartlen Street | Main Street | Tacoma Drive | | | | | X | |
| Herring Cove Road | Armdale Rotary | Purcells Cove Road | | X | | | | X |
| | Purcells Cove Road | Highfield Street | | | | | X | |
| | Highfield Street | Old Sambro | | | | | X | |
| | Old Sambro Road | Auburn Avenue | | X | | | | |
| | Auburn Avenue | Hebridean Drive | | | | | X | |
| Highfield Park Drive | Hwy 111 | Victoria Road | | X | | | | |
| Highway 2 | Sunnylea Road | Rocky Lake Drive | | | | | X | |
| Highway 7 | Forest Hills Parkway | Little Salmon River | X | | | X | | |
| | Highway 107 | Bluerock Road | | | | | X | |
| Hines Road | Main Road | Caldwell Road | | | | | X | |
| Hollis Street | Upper Water Street | Terminal Road | | | | | X | |
| Horseshoe Lake Drive | Susie Lake Crescent | End | | X | X | | | |
| Ilsley Avenue | Wright Avenue | End | | | | | X | |
| Inglis Street | Robie Street | Barrington Street | | | | | X | |
| Innovation Drive | Gary Martin Drive | Hammonds Plains Road | | | | | | X |
| John Brackett Drive | Purcells Cove Road | Hebridean Drive | | | | | X | |
| Joseph Howe Drive | Fairview Overpass | Mumford Road | | X | | | | X |
| | Mumford Road | Craigmore Drive | | X | | | X | |
| | Craigmore Drive | Armdale Rotary | | X | | | | X |
| Joseph Zatzman Drive | Akerley Avenue | Wright Avenue | | X | | | | |
| Jubilee Road | Connaught Avenue | Robie Street | | | | | X | |
| Kearney Lake Road | Larry Uteck Boulevard | Hwy 102 | | | | | X | |
| | Hwy 102 | Dunbrack Street | X | | | | | |
| | Dunbrack Street | Bedford Highway | | | | | X | |
| Kempt Road | Lady Hammond Road | Young Street | | | | | X | |
| Knightsridge Drive | Dunbrack Street | Flamingo Drive | | X | | | | |
| Lacewood Drive | Chain Lake Drive | Titus Street | | X | | | X | |
| Lady Hammond Road | Bedford Highway | MacKintosh Street | | | | | | X |
| | MacKintosh Street | Robie Street | X | | | | | |
| Lake Major Road | Reddy Drive | Main Street | | | | | X | |
| Lakelands Boulevard | Chain Lake Drive | St. Margarets Bay Road | | X | X | | | |
| Larry Uteck Boulevard | Hammonds Plains Road | Kearney Lake Road | | | | | X | |
| | Kearney Lake Road | Southgate Drive | | | | | | X |
| | Southgate Drive | Bedros Lane | | | | | X | |
| | Bedros Lane | Bedford Highway | | X | | | | |
| Lawrencetown Road | Ross Road | Mineville Road | | | | | X | |

| Street Name | Segment | | Minimum Number of Lanes | | Hours of Work | | | |
|-----------------------------|----------------------------------|-------------------------------|--------------------------------------|---------------------------------|---------------|----------------------------------|----------------------|--------------------------|
| | From | To | Maintain two lanes during Peak Hours | Maintain two lanes at all times | PM PHR only | PHR apply only in Peak Direction | Peak Hour Restricted | Evening and Weekend Only |
| Lower Water Street | Terminal Road | George Street | | | X | | | |
| Lucasville Road | Sackville Drive | Hammonds Plains Road | | | | | X | |
| Main Avenue (Halifax) | Washmill Lake Drive | Willet Street | | X | | | | |
| | Willet Street | Titus Street | | | | | X | |
| | Titus Street | Bedford Hwy | | | | | X | |
| Main Road (Eastern Passage) | Pleasant Street | Hines Road | | X | | | X | |
| | Hines Road | Cow Bay Road | | | | | X | |
| Main Street (Dartmouth) | Hwy 111 | Caledonia Road | | X | | | X | |
| | Caledonia Road | Forest Hills Parkway | | X | | X | | |
| Maple Street (Dartmouth) | Thistle Street | Ocheterloney Street | | | | | X | |
| Massachusetts Avenue | Lady Hammond Road | Robie Street | | X | | | X | |
| Meadowbrook Drive | Basinview Drive | Bedford Highway | | | | | X | |
| Metropolitan Avenue | Nictaux Crescent | Glendale Drive | | | | | X | |
| Mimmac Boulevard | Woodland Avenue | Horizon Court | | | | | X | |
| | Horizon Court | Hwy 111 | | X | | | X | |
| Millwood Drive | Sackville Drive | Beaverbank Road | | | | | X | |
| Moirs Mills Road | Amin Street | Bedford Highway | | | | | X | |
| Montebello Drive | Waverley Road | Caledonia Road | | X | | | | |
| Morris Street | South Park Street | Lower Water Street | | | | | X | |
| Mount Edward Road | Woodlawn Road | Ridgecrest Drive | | | | | X | |
| Mount Hope Avenue | Pleasant Street | Baker Drive | | X | | | | |
| Mumford Road | Joseph Howe Drive | Romans Avenue | | | | | X | |
| | Romans Avenue | Chebucto Road | | X | | | X | |
| Nantucket Avenue | Victoria Road | Wyse Road | | | | | | X |
| Norm Newman Drive | Baker Drive | Eisener Boulevard | | | | | X | |
| North Street | Chebucto Road | Barrington Street | | | | | | X |
| North Park Street | Cunard Street | Cogswell Street | | | | | X | |
| North Preston Road | Johnson Road | Reddy Drive | | | | | X | |
| Novalea Drive | Young Street | Duffus Street | | X | | | | |
| Ochterloney Street | Prince Albert Road | Alderney Drive | | | | | X | |
| Old Sambro Road | Herring Cove Road | Dunbrack Street | | | | | X | |
| | Dunbrack Street | Dentith Road | | X | | | X | |
| | Dentith Road | Leiblin Drive | | | | | X | |
| Old Sackville Road | Beaver Bank Connector | Walker Avenue | | | | | X | |
| Osborne Street | Dunbrack Street | Herring Cove Road | | | | | X | |
| Oxford Street | Bayers Road | South Street | | | | | X | |
| Parkland Drive | Kearney Lake Road | Lacewood Drive | | X | | | | |
| Peter Saulnier Drive | Dunbrack Street | Cowie Hill Road | | | | | X | |
| Pinehill Drive | Glendale Drive | Sackville Drive | | | | | X | |
| Pleasant Street | Prince Albert Road | Acadia Street | | | | | X | |
| | Acadia Street | Main Road | | X | | | X | |
| Portland Street | Alderney Drive | Gaston Road | | | | | X | |
| | Gaston Road | Caldwell Road | | X | | | X | |
| Portland Estates Boulevard | Portland Street | Josephine Court | | X | | | | |
| Portland Hills Drive | Portland Street | Berry Hill Drive | | X | | | | |
| Prince Albert Road | Grahams Gove | Sinclair Street | | | X | | X | |
| | Sinclair Street | Alderney Drive | | | | | X | |
| Prince Street (Halifax) | Brunswick Street | Lower Water Street | | | | | X | |
| Princess Margaret Boulevard | Halifax-bound Ramp | Windmill Road | | | | | X | |
| Purcells Cove Road | Herring Cove Road | John Brackett Drive | | | | | X | |
| Queen Street (Halifax) | Sackville Street | South Street | | | | | X | |
| Quinpool Road | Armdale Rotary | Marked Crosswalk @ civic 7121 | | X | | | | X |
| | Marked Crosswalk @ civic 7121 | Robie Street | | X | | | X | |
| Ridgecrest Drive | Main Street | Mount Edward Road | | | | | X | |
| Riverside Drive | Glendale Drive | Sackville Drive | | | | | X | |
| Robie Street | Stairs Street | Almon Street | | X | | | X | |
| | Almon Street | Cunard Street | | X | | | | X |
| | Cunard Street | Inglis Street | | X | | | X | |
| Rocky Lake Drive | Waverley Road | Fraser Drive | | | | | X | |
| | Duke Street | Central Street | | | | | X | |
| | Central Street | Bedford Highway | | | | | | X |
| Ronald Smith Avenue | Ilisley Avenue | Burnside Drive | | | | | | X |
| Sackville Drive (Sackville) | Patton Road (North intersection) | Millwood Drive | | | | | X | |
| | Millwood Drive | Bedford Highway | | X | | | X | |
| Sackville Street (Halifax) | Summer Street | Lower Water Street | | | | | X | |

| Street Name | Segment | | Minimum Number of Lanes | | Hours of Work | | | |
|--|--------------------------|------------------------|--------------------------------------|---------------------------------|---------------|----------------------------------|----------------------|--------------------------|
| | From | To | Maintain two lanes during Peak Hours | Maintain two lanes at all times | PM PHR only | PHR apply only in Peak Direction | Peak Hour Restricted | Evening and Weekend Only |
| Shore Road (Eastern Passage) | Cow Bay Road | Caldwell Road | | | | | X | |
| St. Margarets Bay Road | Ingram River Lane | Albert Walker Drive | | | | | X | |
| | Albert Walker Drive | Armdale Rotary | X | | | | | X |
| South Street | Oxford Street | Hollis Street | | | | | X | |
| South Park Street | Sackville Street | Inglis Street | | | | | X | |
| Spring Avenue | Mount Edward Road | Portland Street | | | | | X | |
| Spring Garden Road | Robie Street | South Park Street | X | | | | X | |
| | South Park Street | Barrington Street | | | | | | X |
| Springvale Avenue | Arlington Avenue | Joseph Howe Drive | | | | | X | |
| Starboard Drive | Larry Uteck Boulevard | Larry Uteck Boulevard | | | | | X | |
| Summer Street | Bell Road | University Avenue | X | | | | X | |
| Susie Lake Crescent | Horseshoe Lake Drive | Chain Lake Drive | X | | X | | | |
| Sussex Street | Old Sambro Road | Herring Cove Road | | | | | X | |
| Tacoma Drive | Gordon Avenue | Valleyfield Road | X | | | | X | |
| | Valleyfield Road | Main Street | | | X | | | |
| Terminal Road | Hollis Street | Lower Water Street | | | | | X | |
| Thistle Street | Wyse Road | Victoria Road | X | | | | X | |
| | Victoria Road | Crichton Park Road | | | | | X | |
| Timberlea Village Parkway | Hwy 103 | St. Margarets Bay Road | | | | | X | |
| Titus Street | Lacewood Drive | Alma Crescent | X | | | | X | |
| Tower Road | Inglis Street | Point Pleasant Drive | | | | | X | |
| Trollope Street | Cogswell Street | Bell Road | | | | | X | |
| University Avenue | LeMarchant Street | South Park Street | X | | | | X | |
| Upper Water Street | Barrington Street | George Street | | | | | | X |
| Valleyfield Road | Tacoma Drive | Woodlawn Road | X | | | | X | |
| Veterans Memorial Drive | Robie Street | Summer Street | | | | | X | |
| Victoria Road | Windmill Road | Albro Lake Road | X | | | | X | |
| | Albro Lake Road | Woodland Avenue | | | | | X | |
| | Woodland Avenue | Nantucket Avenue | | | | | | X |
| | Nantucket Avenue | Portland Street | | | | | X | |
| Walker Avenue | Transit Terminal-civic 7 | Old Sackville Road (N) | | | | | X | |
| Washmill Lake Drive (excl. Under Highway 102 Overpass) | Chain Lake Drive | Dunbrack Street | X | | | | | |
| Waverley Road | Rocky Lake Drive | Breamar Drive | | | | | X | |
| Willet Street | Dunbrack Street | Rosedale Avenue | | | | | X | |
| | Lacewood Drive | Dunbrack Street | X | | | | | |
| Wilkinson Avenue | Wright Avenue | Cutler Avenue | X | | | | | |
| Windgate Drive | Beaverbank Road | Windsor Junction Road | | | | | X | |
| Windmill Road | Bedford Bypass | Victoria Road | X | | | | | X |
| | Victoria Road | Wyse Road | | | | | X | |
| | Wyse Road | Alderney Drive | X | | | | X | |
| Windsor Junction Road | Fall River Road | Cobequid Road | | | | | X | |
| | Bedford Highway | Connaught Avenue | X | | | | X | |
| Windsor Street | Connaught Avenue | Quinpool Road | | | | | X | |
| Woodland Avenue | Victoria Road | Ryland Street | X | | | | X | |
| Woodlawn Road | Main Street | Portland Street | X | | | | X | |
| Wright Avenue | Windmill Road | Hwy 118 | X | | | | X | |
| Wyse Road | Albro Lake Road | Windmill Road | X | | | | X | |
| Young Street | Windsor Street | Robie Street | | | | | X | |
| | Robie Street | Gottingen Street | | | | | X | |

SCHEDULE B – List of Holiday Exemptions to Restricted Streets

| Holiday | Date | Peak Hour Restrictions waived on... |
|--|------------------------------|--|
| New Year's Day | January 1 | ... January 1st. If the holiday is on a Saturday or a Sunday, restrictions are also waived on the first weekday following. |
| Heritage Day | Third Monday in February | ... the holiday only. |
| Good Friday | Floating | ... the holiday only. |
| Victoria Day | Last Monday preceding May 25 | ... the holiday only. |
| Canada Day | July 1 | ... July 1st. If the holiday is on a Saturday or a Sunday, restrictions are also waived on the first weekday following. |
| Natal Day | First Monday in August | ... the holiday only. |
| Labour Day | First Monday in September | ... the holiday only. |
| National Day for Truth and Reconciliation | September 30 | ... September 30th. If the holiday is on a Saturday or a Sunday, restrictions are also waived on the first weekday following. |
| Thanksgiving Day | Second Monday in October | ... the holiday only. |
| Remembrance Day | November 11 | If work must be carried out on November 11 in accordance with the <i>Provincial Remembrance Day Act</i> restrictions will be waived. If Remembrance Day is on a Saturday or a Sunday, restrictions are waived on the first weekday following. |
| Christmas Day | December 25 | ... December 25th. If the holiday is on a Saturday or a Sunday, restrictions are also waived on the first weekday following. |
| Boxing Day | December 26 | ... December 26th. If the holiday is on a Saturday or a Sunday, restrictions are also waived on the first weekday following that date. If both Christmas Day and Boxing Day are on Saturday and Sunday, then restrictions are also waived on the first two weekdays following. |

SCHEDULE C – Document Version Control

Version 2017v01

Published: December 20, 2016

Includes changes to sections 2, 4, 5, 7, 10, 11, and 12, as well as amendments to Schedule A. Schedules C and D repealed.

Version 2018

Published: November 30, 2017

Minor amendments to Schedule A.

Version 2019

Published: January 2019

Includes changes to sections 4, 5, 6, 7, 9, 10, 11, 12, 13, 14, 15, and 16 as well as amendments to Schedule A. Note that additional sections have been added and sections have been renumbered from previous additions.

Version 2020

Published: January 2020

Includes changes to sections 10, 12, and amendments to Schedule A.

Version 2021

Published: January 2021

Includes changes to sections 6, 10, 11, 13 (formerly 12), add new section 12, and amendments to Schedule A. Note that additional sections have been added and sections have been renumbered from previous additions.

SCHEDULE C – Document Version Control

Version 2022

Published: January 2022

Includes minor edits to sections 13, amendment to Schedule A and a new holiday added to section C.

Version 2023

Published: January 2023

Includes minor edits to sections 10, 11 & 12 of the Traffic Control Manual Supplement and amendments to Schedule A.

Version 2024

Published: January 2024

Includes minor edits to sections 6, 13.4 & 14 of the Traffic Control Manual Supplement. Section 7 (Roundabouts) removed and part of Section 12 was removed. This is also accompanied by some changes to the Schedule A – List of Restricted Streets.

PART 1 - GENERAL

- 1.1 Work Included
- 1.2 Related Work
- 1.3 References
- 1.4 Shop Drawing and Product Data
- 1.5 Closeout Submittals

PART 2 – PRODUCTS

- 2.1 General
- 2.2 Ornamental Street Lighting
- 2.3 Concrete Bases (Metal Poles)
- 2.4 Poles
- 2.5 Lighting Control Nodes
- 2.6 Street Lighting Luminaires
- 2.7 Conduit
- 2.8 Mounting Equipment

PART 3 – EXECUTION

- 3.1 General
- 3.2 Grounding
- 3.3 Pole and Base Installation
- 3.4 Bracket Installation
- 3.5 Wiring Installation
- 3.6 Luminaries Installation
- 3.7 Luminaire Cleaning
- 3.8 Commissioning and Take Over

PART 1 - GENERAL

- 1.1 Work Included .1 This section specifies the requirements to supply and install lighting equipment including poles, bases, conduit, luminaires, and mounting accessories.
- 1.2 Related Work .1 General Requirements: Section 01 10 00
.2 Metal Fabrications: Section 05 50 00
.3 Concrete: Section 03 30 00
.4 Ornamental Street Lighting Map: Attachment A
- 1.3 References .1 ANSI/IES RP-8 – 18, Roadway Lighting.
.2 IEEE C62.41.1-2002, Guide on the Surge Environment in Low-Voltage (1000 V and Less) A/C Power Circuits.
.3 ANSI/NEMA C136.41-2013, Standard for Roadway and Area Lighting – Dimming Control.
.4 ASTM B117-18, Standard Practice for Operating Salt Spray (Fog) Apparatus.
.5 ASTM C1804-14e1, Standard Specification for Spun Cast Prestressed Concrete Bases for Tapered Steel Lighting Poles.
.6 ASTM C1824-16e1, Standard Test Method for Full Scale Bending Test of Spun, Prestressed Concrete Bases for Tapered Steel Lighting Poles.
.7 ANSI C136.15-2015 Standard for Roadway Lighting Equipment - Luminaire Field Identification.
.8 CSA C22.2 No. 41-13(R2017), Grounding and Bonding Equipment.
.9 CSA C22.2 No. 45.1-07(R2017), Electrical Rigid Metal Conduit.
.10 CSA C22.2 No. 206-17, Lighting Poles.
.11 CSA 22.2 No. 211.2-06(R2016), Rigid PVC Conduit.
.12 CSA A23.4-16, Precast Concrete - Materials and Construction.
- 1.4 Shop Drawings And Product Data .1 Submit shop drawings and product data in accordance with Section 01 10 00.
.2 Submit shop drawings for the following:
.1 Luminaire.
.2 Lamp for each luminaire type.

- .3 Driver for each luminaire type.
- .4 Poles and brackets.
- .5 Lighting control nodes.
- .3 Shop Drawings:
 - .1 Shop drawings to clearly indicate the following:
 - .1 Unique Luminaire ID number.
 - .2 Fixture specification as identified in Part 2.
 - .3 Driver specification as identified in Part 2.
 - .4 Controller specification as identified in Part 2.
 - .5 Photometric data for each luminaire type.
 - .6 Pole and base detail including anchor belt sizing.
 - .4 Catalogue cuts lacking sufficient detail to indicate compliance with Contract documents will not be acceptable.
 - .5 Submit complete photometric data prepared by independent testing laboratory for luminaires where specified, for review by the Engineer. Photometric data to include:
 - .1 VCP Table, spacing criterion;
 - .2 Total input watts;
 - .3 Candlepower summary, candela distribution, zonal lumen summary;
 - .4 Luminaire efficiency, C.I.E. type, coefficient of utilization;
 - .5 Lamp type;
 - .6 Lumen ratings; and
 - .7 Summary in accordance with IES procedures.
- 1.5 Closeout Submittals
 - .1 Provide operation and maintenance data as well as any special tools, cleaners or spares for all materials supplied herein in accordance with Section 01 10 00.
 - .2 Provide the following additional spare material for each type of item specified in the Work:
 - .1 10% spare poles, minimum of one (1).
 - .2 10% metal poles, minimum of one (1).
 - .3 10% of brackets, minimum of one (1).

PART 2 - PRODUCTS

- 2.1 General
 - .1 All lighting equipment and connectors must be compatible with HRM's existing lighting systems and must be approved by HRM prior to ordering.

- .2 Provide equipment designed to meet or exceed wind loading requirements as set forth in the National Building Code for the HRM region.
- 2.2 Ornamental Street Lighting .1 Provide the ornamental fixtures as shown on Attachment A – Ornamental Street Lighting Map, appended at the end of this Section.
- 2.3 Concrete Bases (Metal Poles) .1 Precast:
 - .1 Concrete: to CSA A23.4.
 - .2 Prestressed concrete bases: to ASTM C1804, tested to ASTM C1824..2 Cast-in-Place to Section 03 30 00.
- 2.4 Poles .1 To CSA C22.2 No. 206.
 - .2 Pole wiring to be #12/2 NMWU.
 - .3 Handhole: to HRM Detail 103
 - .4 Acceptable Products:
 - .1 Wood Poles - 9.3 m – to CSA C22.2 No. 206
 - .2 Metal Poles:
 - .1 4.7 m Aluminum – Valmont 11-2506C0860
 - .2 7.3 m Aluminum – Valmont 11-3504C0860-1
 - .3 9.1 m Aluminum – Valmont 12-40010E1060
- 2.5 Lighting Control Nodes .1 ANSI 7-Pin design.
 - .2 Integrated GPS connectivity to report Latitude/Longitude coordinates.
 - .3 Battery – backed real-time clock.
 - .4 Universal AC input 85V-264V or 347V as required for street lighting fixture, 50/60Hz.
 - .5 Revenue grade energy measurement and reporting via web based software.
 - .6 Wireless mesh-network communication.
 - .7 Capable of dimming, on/off, and scheduling control of connect light fixture.
 - .8 Minimum IP65 rating.
 - .9 Suitable for operation in -40°C to 70°C ambient environments.

- .10 Minimum 1000W, 1800VA load rating with minimum 15A switching.
 - .11 Integrated photocell.
- 2.6 Street Lighting
Luminaires
- .1 Surface mounted incandescent luminaire suitable for mounting in a wet location.
 - .2 Rating: 120V or 347V as required, based on local utility secondary voltage.
 - .3 Light Output: As required to comply with Halifax Street Lighting Standards and ANSI/IES RP-8.
 - .4 Housing: low copper alloy die cast aluminum, complete with minimum 2 mil thick polyester powder coat.
 - .5 Luminaire and finishes must pass the 1000 hour salt test per ASTM B117.
 - .6 Minimum 88,000 hour rated life at 20 degrees Celsius to 80% of rated initial output (IES LM-80).
 - .7 Fixture to be adjustable +/- 5 degrees relative to mounting arm.
 - .8 Provide fixture complete with permanent internal labelling which must be entirely legible for the lifetime of the luminaire, indicating:
 - .1 Manufacturer's Name
 - .2 Catalogue Number
 - .3 Date of Manufacture
 - .4 Rated luminaire voltage
 - .5 Rated Luminaire wattage
 - .9 Waterproof permanent label on exterior of fixture indicating fixture wattage, clearly visible from street level.
 - .10 IP66 fixture rating.
 - .11 0-10V DC Dimmable driver.
 - .12 7-pin receptacle for twist lock photo controller per ANSI C136.41 and Lighting Control Node (see 2.4).
 - .13 Complete with internal or external surge suppression achieving Category C High (10kV, 10kA) per IEEE C62.41.1.
 - .14 Color Rendering Index (CRI) greater than or equal to 80.
 - .15 IES type II distribution for roadway applications, IES type IV distribution for all cul-de-sac turning circles.
 - .16 Up-light component of fixture BUG rating to be not greater than U0.
 - .17 Acceptable Products:

- .1 AEL ATB0/ATB2 series
 - .2 LRL – NXT series.
- 2.7 Conduit
- .1 Minimum conduit size to be 38 mm, except 16 mm for connections to fixture brackets.
 - .2 Metal Conduit: to CSA C22.2 No. 45.1.
 - .3 PVC Conduit: to CSA C22.2 No. 211.2.
- 2.8 Mounting Equipment
- .1 Brackets to be nominally 1800 mm, or 3050 mm in length, single member arm, galvanized steel, elliptical in shape and adjustable as required for application to achieve the Halifax Design Standards and IES RP-8.

PART 3 - EXECUTION

- 3.1 General
- .1 When connecting any fixture to Nova Scotia Power (NSP) infrastructure, follow all NSP installation specifications and details as shown on the Project Drawings.
 - .2 Confirm, through survey review, the locates of underground infrastructure and review overhead wire routing prior to excavation to avoid conflicts or obstructions and achieve required offsets.
 - .3 Ground transformer base with a grounding lug.
 - .4 Ground u-guard to main service ground.
 - .5 Before beginning the Work, review the overhead wire routing for conflicts or obstructions. Report any conflicts or obstructions to the Engineer who will provide a resolution.
 - .6 Obtain a Fixture (FX) and Support (SS) number from the Owner prior to commencing installation.
 - .7 Provide a list of MAC addresses and associated serial number prior to commencing installation.
- 3.2 Grounding
- .1 Ground equipment and wiring in accordance with CSA C22.2 No. 41.
- 3.3 Pole and Base Installation
- .1 Where cast-in-place bases are used, do concrete work in accordance with Section 03 30 00 – Concrete.

- .2 Support poles in cast-in-place bases as required during construction.
 - .3 Grease all screws and bolts using never seize paste.
 - .4 Do not weld nuts.
 - .5 Use lock washers on all anchor bolts.
 - .6 Split bolts are not acceptable.
 - .7 Every pole must have a separate ground plate installed and bonded to pole through ground lug.
 - .8 Set all poles on concrete bases. Do not set on nuts, Orientate poles such that they are parallel to the roadway.
 - .9 Install a fuse kit for every individual head.
- 3.4 Bracket Installation
- .1 Install bracket prior to installing street lighting fixture.
 - .2 Use through bolt with square washer in addition to 16 mm lag bolt to secure arm to pole.
 - .3 Connect ground to bracket via ground bolt.
 - .4 Connect 16 mm NM LTF to bracket.
- 3.5 Wiring Installation
- .1 Identify electrical circuits using numbered wire tags, not duct tape or masking tape. Clearly identify the neutral.
 - .2 Minimum wire size #8AWG R90 XLPE Simpull.
 - .3 Tape wire connectors with super 88 electrical tape.
 - .4 Make overhead connections using piercing connectors.
 - .5 Run underground electrical joints to the nearest pole. Avoid the usage of underground junction boxes where possible.
 - .6 All wire runs to contain an extra conductor as a spare.
 - .7 For overhead connections, use a piercing type connector.
 - .8 Cut off conduits 100mm high above concrete base and not level with concrete base.
 - .9 Where possible, minimize bends to two (2) 90° bends in each run from pole to pole.
- 3.6 Luminaries Installation
- .1 Install luminaires in accordance with the manufacturer's written instructions and in accordance with the Engineer's written approval.

- 3.7 Luminaire Cleaning
- .1 Clean luminaires one (1) week prior to Substantial Performance.
 - .2 Replace blemished, damaged or unsatisfactory luminaries as directed by the Engineer.
- 3.8 Commissioning and Take Over
- .1 Prior to take over of any new lighting installations by the Owner, arrange for commission by the Owner or their designated representative.
 - .2 Make arrangements for commissioning a minimum of one (1) week prior to completing Work.
 - .3 Assist the process of commissioning as required.
 - .4 Once commissioning is complete, the Owner will take over the system.

**** End 26 50 00 ****

INDEX TO CLAUSES**PART 1 - GENERAL**

- 1.1 Work Included
- 1.2 Work Not Included
- 1.3 Related Work
- 1.4 References
- 1.5 Submittals
- 1.6 Protection
- 1.7 Delivery and Storage
- 1.8 Allowable Tolerances
- 1.9 Warranty

PART 2 – PRODUCTS

- 2.1 Materials

PART 3 – EXECUTION

- 3.1 Dewatering
- 3.2 Soil Preparation
- 3.3 Installation and Review
- 3.4 Protection
- 3.5 Adjustment and Cleaning
- 3.6 Reinstatement

PART 1 - GENERAL

- 1.1 Work Included .1 This Section contains performance specifications for the provision of design and construction of prefabricated wet cast or dry cast segmental concrete unit gravity retaining walls and associated appurtenances to the lines and levels indicated on the Project drawings.
- 1.2 Work Not Included .1 This section does not cover:
.1 Walls greater than 3.0m in height.
.2 Mechanically Stabilized Earth Walls requiring a designed tie back system.
- 1.3 Related Work .1 Metal Fabrications: Section 05 50 00
.2 Earthwork: Section 31 20 00
.3 Reinstatement: Section 32 98 00
- 1.4 References .1 ASTM D1557 (latest edition), Test Methods for Laboratory Compaction Characteristics of Soil Using Modified Effort (45,000 ft-lbf/ft³ - 2,700 KN-m/m³).
.2 ASTM C1372 (latest edition), Standard Specification for Dry-Cast Segmental Retaining Wall Units.
.3 ASTM C1262/C1262M (latest edition), Standard Test Method for Evaluating the Freeze-Thaw Durability of Dry-Cast Segmental Retaining Wall Units and Related Concrete Units.
.4 ASTM C1776/C1776M (latest edition), Standard Specification for Wet-Cast Precast Modular Retaining Wall Units.
.5 ASTM C94/C94M (latest edition), Standard Specification for Ready-Mixed Concrete.
.6 ASTM C143/C143M (latest edition), Standard Test Method for Slump of Hydraulic-Cement Concrete.
.7 CSA B1800 (latest edition), Thermoplastic Nonpressure Piping Compendium.

- .8 CSA G164 (latest edition), Hot Dip Galvanizing of Irregularly Shaped Articles.
 - .9 CSA S6-19 (latest edition), Canadian Highway Bridge Design Code.
 - .10 National Concrete Masonry Association (NCMA) Design Manual for Segmental Retaining Walls, Third Edition.
- 1.5 Submittals
- .1 Submit designs and details of prefabricated segmental concrete retaining wall systems for review by the Engineer in accordance with Section 01 10 00.
 - .2 For walls over 1.0m in height, as measured from the finished grade to the top of the wall, design and shop drawings must be stamped by a professional engineer licensed to practice in the Province of Nova Scotia.
 - .3 Design wall system in accordance with the recommendations set forth in NCMA Design Manual for Segmental Retaining Walls and the requirements of CSA S6.
 - .4 Designs to provide for level installation of precast unit courses and be of sufficient design to retain areas indicated, accommodate live load surcharge in retained area, support handrail where indicated, support snow windrow loading, and sustain minor impacts without prefabricated concrete unit failure. Submissions to include all necessary items to provide for installation of the required retaining wall systems including but not necessarily limited to:
 - .1 Plans and elevations.
 - .2 Cross-sectional details.
 - .3 Slope above and below the wall
 - .4 Miscellaneous details including anchoring, railings and drainage.
 - .5 Soil strength design parameters for backfill, levelling pad, infill, and drainage layer.
 - .6 Code references.
 - .5 Where additional fill is needed, submit sample and specifications to the Engineer for review.
- 1.6 Protection
- .1 Prevent damage to landscaping, fences, adjacent property and all other items designated to remain.

- | | | | |
|-----|-----------------------------|----|---|
| 1.7 | <u>Delivery And Storage</u> | .1 | Check materials upon delivery to assure proper material has been received. |
| | | .2 | Prevent excessive mud, wet cement, and like material from coming in contact with the materials. |
| | | .3 | Protect materials from damage. Do not incorporate damaged materials into the project. Promptly remove damaged units from the site. |
| | | .4 | Do not stack units more than two high. |
| 1.8 | <u>Allowable Tolerances</u> | .1 | Finished top of wall surface to within 25mm of specified elevations and locations, and within a tolerance of 12mm for both top and face surfaces when measured under a 3.0m long straightedge. |
| 1.9 | <u>Warranty</u> | .1 | Provide a warranty that expressly states the retaining wall is covered for a period of two (2) years from the date of Substantial Completion against workmanship, heaving, or settlement and cracking, spalling or other product failure. |

PART 2 - PRODUCTS

- | | | | |
|-----|------------------|----|--|
| 2.1 | <u>Materials</u> | .1 | Provide a precast segmental retaining wall system complete with, but not necessarily limited to, the following: <ul style="list-style-type: none">.1 Block units:<ul style="list-style-type: none">.1 Wet cast segmental units:<ul style="list-style-type: none">.1 To ASTM C1776..2 Minimum compressive strength: 28 MPa..3 Free of water soluble chlorides and chloride based accelerator admixtures..4 6% +/- 1½% air-entrainment in conformance ASTM C94..5 Maximum slump of 125 mm +/- 40 mm per ASTM C143 for conventional concrete mix designs..2 Dry cast segmental units:<ul style="list-style-type: none">.1 To ASTM C1372..2 Passing freeze thaw tests as set forth in ASTM C1262/C1262M with an average absorption rate of 120kg/m3. |
|-----|------------------|----|--|

- .3 Compressive strength range: 28-40 MPa in accordance with ASTM C1372.
- .4 Infill rock/soil: as approved by the Engineer.
- .3 Block units may be mass concrete or designed to incorporate granular infill.
- .2 Gravel levelling pad and/or concrete footing as required by design.
- .3 Prefabricated concrete units including bottom, intermediate, end, top and cap units as required.
- .4 Drainage tile: perforated pipe, polyvinyl chloride (or approved equivalent), diameter as indicated, to CSA B1800, capable of being tied into new storm system construction. Provide connection to existing storm system in accordance with Section 33 39 00.
- .5 Geotextile: to Section 31 15 53.
- .6 Metal fabrications: posts, handrails, anchors, and fasteners to Section 05 50 00, galvanized to CSA G164. Provide design details to accommodate anchorage of railing, including infill materials, infill concrete or grout, holes drilled in block units, fasteners, all in accordance with the railing design.
- .7 Backfill Material:
 - .1 Free Draining Backfill material to be granular, well-draining stone placed to a minimum of 300 mm depth behind the back of the wall and shall extend vertically from the leveling pad or concrete footing to an elevation 100 mm below the top of wall.
 - .2 Backfill material must be approved by a geotechnical engineer licensed to practice in the Province of Nova Scotia. Site excavated soils may be used if approved, unless otherwise specified in the drawings. Do not use unsuitable soils as defined in Section 31 20 00, organic soils and frost susceptible soils within a 1 to 1 influence area.
- .8 Anchored wall cap or top unit.
- .9 Face texture: Cobblestone texture, gray in color, or as shown in the Tender Drawings.
- .2 Granular Fill: where required, use Type 1 gravel as specified in Section 31 20 00.

PART 3 - EXECUTION

- | | | | |
|-----|--------------------------------|----|--|
| 3.1 | <u>Dewatering</u> | .1 | Perform dewatering in accordance with accepted method and in accordance with Section 31 20 00. |
| 3.2 | <u>Soil Preparation</u> | .1 | Complete excavations in accordance with approved submissions, Section 31 20 00 and as indicated on Drawings. Notify the Engineer of unsatisfactory conditions. |
| | | .2 | Confirm site foundation soil strength meets or exceeds assumed design strength. Submit results to the Engineer for review. |
| | | .3 | Remove and replace soil not meeting the required strength with acceptable material. Compact to a minimum 95% to ASTM D1557 Density. |
| | | .4 | Place geotextile between the Free Draining Backfill and retained soil as required. |
| 3.3 | <u>Installation and Review</u> | .1 | Install retaining wall system in accordance with approved submission and manufacturer's recommendations including preparation of levelling pad, block unit, infill (where applicable), backfill and drainage layer, compaction, geotextile, railing, and associated work in accordance with the Engineer and the design requirements of the wall designer. |
| | | .2 | Have contractor provide sealed drawings and certification of finished retaining wall construction, by a Professional Engineer (P.Eng.) licensed to practice in Nova Scotia. |
| 3.4 | <u>Protection</u> | .1 | Protect and maintain work of this Section including accessories, until acceptance of project work. |
| 3.5 | <u>Adjustment and Cleaning</u> | .1 | Replace entire units that are defective. Immediately remove from site defective and damaged materials. Replace, repair, re-finish, or otherwise make good to the Engineer's review. |
| 3.6 | <u>Reinstatement</u> | .1 | Reinstate any damaged surface adjacent to the Work area in accordance with Section 32 98 00. |

**** END SECTION 32 32 23 ****

INDEX TO CLAUSES

PART 1 - GENERAL

- 1.1 Work Included
- 1.2 Related Sections
- 1.3 Reference Standards
- 1.4 Quality Control
- 1.5 Delivery, Storage and Protection
- 1.6 Samples
- 1.7 Warranty
- 1.8 Definitions

PART 2 - PRODUCTS

- 2.1 Plant Materials
- 2.2 Species Selection
- 2.3 Water
- 2.4 Tree Support
- 2.5 Mulch
- 2.6 Fertilizer
- 2.7 Anti-desiccant
- 2.8 Flagging Tape

PART 3 - EXECUTION

- 3.1 General
- 3.2 Pre-planting Operations
- 3.3 Preparation of Planting Beds and Pits
- 3.4 Planting
- 3.5 Tree Supports
- 3.6 Mulching
- 3.7 Maintenance During Establishment Period
- 3.8 Acceptance
- 3.9 Maintenance During Warranty Period
- 3.10 Clean Up

PART 1 - GENERAL

- 1.1 Work Included .1 This section specifies requirements for planting of trees, shrubs and groundcover. Work includes:
- .1 Developing and managing planting plans, weekly schedules, and digital planting inventories;
 - .2 Supply and installation of planting soil mix or soil amendments;
 - .3 Supply and planting of trees, shrubs and groundcover complete with all related components and accessories.
- 1.2 Related Sections
- .1 Environmental Protection Section 01 57 00
 - .2 Clearing and Grubbing Section 31 10 00
 - .3 Earthwork Section 31 20 00
 - .4 Protection of Existing Trees Section 32 91 10
 - .5 Topsoiling and Finish Grading Section 32 91 19
 - .6 Seeding and Sodding Section 32 92 00
- 1.3 References
- .1 Canadian Nursery Landscape Association (CNLA), Standards Canadian Standards for Nursery Stock. Canadian Landscape Standard (CLS), 2nd edition
- 1.4 Quality Control
- .1 Obtain approval of plant material prior to planting.
 - .2 Supply necessary permits and import licenses in compliance with federal and provincial regulations for imported plant material.
 - .3 HRM Urban Forestry and/or HRM's Landscape Architect may review all plants subject to approval of size, health, quality, character, etc.
- Review or approval of any plant during the process of selection, delivery, installation and establishment period shall not prevent that plant from later rejection in the event that the plant quality changes, or defects become apparent.

-
- .4 HRM Urban Forestry and/or HRM's Landscape Architect reserves the right to select and observe all plants prior to planting and to reject plants that do not meet specifications.
- .5 The contractor shall be responsible for documenting the locations of all plantings on an as-built drawing complete with an accompanying plant schedule and key.
- .6 All plants that are rejected shall be immediately removed from the site and acceptable replacement plants provided at no additional cost.
- 1.5 Delivery, enclosed Storage and Protection
- .1 Protect plant material from damage during transportation. Use an vehicle or other approved method.
- .2 Immediately store and protect plant material which will not be installed within 1 hour after arrival at site in an approved storage location.
- .3 Protect plant material from frost, excessive heat, wind, and sun during and after delivery as follows:
- .1 For pots and containers, maintain moisture level in containers.
- .2 For balled and burlapped and wire basket root balls, place to protect branches from damage. Maintain adequate moisture level in root zones.
- .3 For bare root plant material, preserve moisture around roots by heeling-in or burying roots in approved moisture-retaining medium and watering to full depth of root zone.
- 1.6 Samples
- .1 Submit samples in accordance with Section 01 10 00 for items listed in Supplementary Specifications.
- 1.7 Warranty
- .1 Notwithstanding GC 25 - WARRANTY, warrant that plant material provided will be maintained to remain healthy and free of defects for two (2) years from the date of final acceptance or as specified in the Project Documents, subject to sub-section 3.9.
- .2 Extend warranty period an additional one (1) year for plant materials if leaf development and growth is not sufficient at the end of the original warranty period to ensure future survival as determined by the Engineer or designated consultant.
- 1.8 Definitions
- .1 Defective Plant: Any plant that fails to meet the plant quality requirement of this specification.

PART 2 - PRODUCTS

2.1 Plant
Materials

- .1 Type of root preparation, sizing, grading and quality: comply with Canadian Nursery Landscape Association (CNLA) Standards. All trees to be Canada #1 Nursery Grown.
- .2 Plant material: free of disease, insects, pests, defects or injuries, structurally sound with strong fibrous root system, of excellent vigor and condition, and with the roots pruned regularly.
- .3 Trees: with straight trunks, well and characteristically branched for species except where specified otherwise, straight stem, full crown and main leader.
- .4 Bare root stock: nursery grown, in dormant stage, not balled and burlapped or container grown.
- .5 Collected native stock not acceptable unless otherwise approved.
- .6 No substitutions shall be permitted without the written approval of the Engineer and/or HRM Urban Forestry.
- .7 The Contractor shall provide plants of quality, size, genus, species, and variety or cultivars as shown and scheduled in the Project Documents or as specified in HRM's Municipal Design Guidelines or as approved by the Urban Forester.
- .8 Unless otherwise stipulated all conifer shall be 150cm W.B. stock balled and burlapped and all other trees shall be 60mm caliper balled and burlapped.
- .9 All trees shall be true to name as ordered or shown on planting plans and shall be labeled individually or in groups by genus, species, variety and cultivar.
- .10 Tags bearing species and genus information shall be retained on individual trees until approved by HRM Urban Forestry or designate.
- .11 All balled and burlapped plants shall be field grown, and the root ball packaged in a burlap and twine and /or burlap and wire basket package.
- .12 Trees shall be harvested with a tree spade within the same calendar year that they will be planted.
- .13 The tree trunk shall be relatively straight, vertical, and free of wounds that penetrate to the wood (properly made pruning cuts,

closed or not, are acceptable and are not considered wounds), sunburned areas, conks (fungal fruiting bodies), wood cracks, sap leakage, signs of boring insects, galls, cankers, girdling ties, or lesions (mechanical injury).

- .14 Shoot growth (length and diameter) throughout the crown should be appropriate for the age and size of the species or cultivar.
- .15 Trees shall not have dead, diseased, broken, distorted, or otherwise injured branches.
- .16 All graft unions, where applicable, shall be completely closed without visible sign of graft rejection. All grafts shall be visible above the soil line. The root collar shall be within the upper 5 (five) cm of the substrate/soil.

2.2 Species Selection

- .1 The following species have been approved for use within the HRM Right-of-Way. In addition to the presence of overhead utilities (see note below), species selection should include consideration of tree canopy space and shadows, especially when planting trees near tall buildings. Additional species may be considered, subject to the approval of the Urban Forester.

- .1 List of Acceptable Tree species for replanting (*site where tree previously existed*):

A) Acceptable tree species for plantings under single or 2-phase Distribution Lines:

- Red Maple; *Acer rubrum* (*species & cultivars*)
- Freeman Maple; *Acer x fremannii* (*cultivars*)
- Pin Oak; *Quercus palustris*
- American Elm; *Ulmus americana* (DED resistant cultivars e.g. 'Princeton', 'Liberty', 'Prospector')
- Kentucky Coffee tree; *Gymnocladus dioicus*
- European Beech; *Fagus sylvatica* (tree form only)
- American sycamore; *Platanus occidentalis*
- Sweetgum; *Liquidambar styraciflua*
- Common Hackberry; *Celtis occidentalis*
- Honeylocust; *Gleditsia triacanthos* Inermis
- Tuliptree; *Liriodendron tulipifera*
- Cucumbertree; *Magnolia acuminata*

B) Acceptable tree species for plantings under 3-phase, single circuit Distribution:

- *All species from 'A)' above*
- *All species from 'C)' below*

C) Acceptable tree species for plantings under 3-phase, double circuit Distribution Lines:

- Hedge Maple; *Acer campestre*
- Crabapple; *Malus x hybrids*
- Japanese Tree Lilac; *Syringa reticulata*
- American Hophornbeam; *Ostrya virginiana*
- Ornamental Pear; *Pyrus calleryana* cultivars, *Pyrus ussuriensis*
- Katsura; *Cercidiphyllum japonicum*
- Amur Maackia; *Maackia amurensis*
- Ginkgo (male selection); *Ginkgo biloba*
- Red Oak; *Quercus rubra*
- Burr Oak; *Quercus macrocarpa*
- Swamp White Oak; *Quercus bicolor*

2. List of Acceptable Tree species for new planting (*Site where no tree previously existed*)

D) Acceptable tree species for plantings under single or 2-phase Distribution Lines:

- Red Maple; *Acer rubrum* (*species & cultivars*)
- Freeman Maple; *Acer x fremannii* (*cultivars*)
- Pin Oak; *Quercus palustris*
- American Elm; *Ulmus americana* (DED resistant cultivars e.g. 'Princeton', 'Liberty', 'Prospector')
- Kentucky Coffee tree; *Gymnocladus dioicus*
- European Beech; *Fagus sylvatica* (tree form only)
- American sycamore; *Platanus occidentalis*
- Sweetgum; *Liquidambar styraciflua*
- Common Hackberry; *Celtis occidentalis*
- Honeylocust; *Gleditsia triacanthos* Inermis
- Tuliptree; *Liriodendron tulipifera*
- Cucumber tree; *Magnolia acuminata*

E) Acceptable tree species for plantings under 3-phase, single & double circuit Distribution Lines:

- Hedge Maple; *Acer campestre*
- Crabapple; *Malus x hybrids*
- Japanese Tree Lilac; *Syringa reticulata*
- American Hophornbeam; *Ostrya virginiana*

- Ornamental Pear; *Pyrus calleryana* cultivars, *Pyrus ussuriensis*
- Katsura; *Cercidiphyllum japonicum*
- Amur Maackia; *Maackia amurensis*
- Ginkgo (male selection); *Ginkgo biloba*
- Species substitutions may be considered under approval of both HRM and NSPI

Note: Any species of *Fraxinus* (ash) are currently considered unacceptable for planting in HRM due to the influx of the Emerald Ash Borer pest.

- 2.3 Water .1 Free of impurities that would inhibit plant growth.
- 2.4 Tree Support .1 Stakes: wood, regular or treated, 25 x 40 x 2400 mm long, or as detailed in Project Documents.
- .2 Turnbuckle: galvanized steel, 9 mm diameter with 250 mm open length. Painted fluorescent orange.
- .3 Guying wire: galvanized steel, 3 mm wire or 3 mm diameter multi-wire steel cable.
- .4 Anchors:
.1 Wood: 50 mm x 50 mm x 600 mm.
.2 Steel: T-bar, 600 mm.
- .5 Guying collar: tube, plastic 13 mm diameter nylon reinforced, rubber hose or approved commercial equivalent or as detailed in Project Documents.
- 2.5 Mulch .1 Organic:
.1 Bark Mulch: Aged, shredded, bark and wood from coniferous trees or approved commercial bark nugget. Maximum length of any individual component to be 50 mm and a minimum of 75% of the mulch will pass through a 25 mm screen. Mulch to be free of growth or germination-inhibiting ingredients. Mulch to have characteristics of retaining moisture, forming a mat not susceptible to spreading by wind or rain, and providing a good growth medium for plants. Shredded bark may contain up to 50% shredded wood material. Wood chips are not acceptable. Bark mulch containing shredded wood to be aged for one (1) year minimum prior to installation.
- .2 Inorganic:
.1 Washed River Rock: To be 25 mm to 76 mm washed river rock, uniform in size. All fines shall be screened from the

aggregate within a 6mm tolerance. Rock mulch to be composed of round stones or pebbles that may be varied in colour. The material must be free of organic and inorganic debris and litter.

- 2.6 Fertilizer .1 Slow release, inorganic granular fertilizer; as determined by soil test.
- 2.7 Anti-Desiccant .1 A waxy or polymer spray providing a protective coating to evergreen foliage and reducing the amount of water that escapes.
- 2.8 Flagging Tape .1 Fluorescent, colour choice optional.

PART 3 - EXECUTION

- 3.1 General .1
- Qualifications
- .1 The Contractor and its crews shall have at least two (2) years of successful experience of a scope similar to that required for the work, including the handling and planting of large specimen trees in urban areas.
- .2 The planting crew shall employ at least one (1) person who is a member in good standing of Landscape Nova Scotia.
- .2 Planting Season
- .1 Planting shall only be performed when weather and soil conditions are suitable for planting the materials specified in accordance with locally accepted practice.
- .2 Install plants during the planting time as described above unless otherwise approved in writing by HRM Urban Forestry.
- .3 In the event that the Contractor requests planting outside the dates of the planting season, approval of the request does not change the requirements of the warranty.
- .3 Site Examination
- .1 Examine the surface grades and soil conditions. Placement of trees to be verified in field; do not place trees over gas, sewer, or water laterals or within proximity to Halifax Water infrastructure such as catch basins, manholes or fire hydrants. For manholes and catch basins, the offset guideline from centre of the infrastructure is 1.5 metres, or as much as possible. However, where no other suitable locations exist, trees may be located closer with the approval of the Engineer or Urban Forestry.
- .2 Notify HRM Urban Forestry in writing of any unsatisfactory conditions.
- .3 It is the responsibility of the Contractor to visit the planting sites and assess all requirements.

- .4 Delivery, Storage and Handling
 - .1 Protect materials from deterioration during delivery and storage. Adequately protect plants from drying out, exposure of roots to sun, wind or extremes of hot and cold temperatures.
 - .2 Plants and trees are to be planted the day they arrive on site. If planting is delayed more than 24 hours after delivery, set plants in a location protected from sun and wind.
 - .3 Provide adequate water to the root ball package during the shipping and storage period.
 - .4 Do not deliver more plants to the site that there is space with adequate storage conditions. Provide a suitable remote staging area for plants and other supplies.
 - .5 Provide protective covering over all plants during transporting.
 - .6 Provide protective covering on equipment that will cause bark damage during transportation, such as tailgate padding, etc.
 - .7 Trees are to be handled, transported and planted in a manner that does not cause damage or injury to trunk/crown or root ball.
 - .8 Trees shall be lifted by the root ball and not by the trunk when being moved or set into the planting hole.
 - .9 Root systems of balled specimens shall be handled with sufficient care so that root balls shall not be broken. Broken balls or balls consisting of loose soil will not be accepted and shall be replaced.

3.2 Pre-planting
Operations

- .1 Observe each plant after delivery and prior to installation for damage or other characteristics that may cause rejection of the plant. Notify the Urban Forester of any adverse condition observed.
- .2 Prune and remove damaged roots and branches from plant material using proper pruning cuts.
- .3 Apply anti-desiccant to conifers and deciduous trees in accordance with manufacturer's directions. Apply anti-desiccant when material is dug out of recommended season for protection, during extreme temperatures and such other conditions deemed necessary by the Engineer or designated consultant.

3.3 Preparation
of Planting Beds
and Pits

- .1 Obtain approval of plant materials prior to use.
- .2 Excavate to depth and width as indicated. Excavated planting holes shall not be left overnight.

- .3 Excavate the planting hole to the depth of the root ball, measured after any root ball modification. The hole shall be wide enough to allow for working around the root ball, or to the size indicated on the drawing or as noted.
- .4 In the event that ground conditions and/or excessive rock does not allow for section (.3) to be achieved, the contractor shall report to the Urban Forester.
- .5 Remove damaged roots and branches from plant material.

3.4 Planting

- .1 For bare root stock, place 50 mm planting mixture in bottom of pit. Plant trees and shrubs with roots placed straight in pit.
- .2 For jute or biodegradable burlapped root balls, untie and fold back top one third to one half of wrapping, remove the top layer of the wire basket, and fold down remaining protruding wire sections without damaging root ball. Do not pull burlap or rope from under root ball. The wire basket should not be removed entirely as doing so may destroy the integrity of the root ball, particularly if the tree was dug in sandy or dry soil.
- .3 For container stock or root balls in non- degradable wrapping, water plants and then remove entire container or wrapping without damaging root ball. Under no circumstances should non-biodegradable burlap or cloth material be allowed to remain around the soil ball after planting.

All plant material in containers shall be checked to ensure that there are no encircling or girdling roots. If encircling roots are present, use a sharp knife to make two vertical cuts opposite each other on the sides of the root ball through the encircling roots.

- .4 Plant plumb in locations indicated. Orient plant material to give best appearance in relation to structure, roads and walks.
- .5 The root system of each plant, regardless of root ball package type, shall be observed by the Contractor, at the time of planting to confirm that the roots meet the requirements for plant root quality. The Contractor shall undertake at the time of planting all modifications to the root system required by HRM Urban Forestry to meet these quality standards.
- .6 For trees and shrubs:
 - .1 Backfill planting mixture in 150 mm lifts. Tamp each lift to eliminate air pockets. When two thirds of depth of planting pit has been backfilled, fill remaining space with water. After water has penetrated into planting mixture, backfill to finish grade. Confirm that the final grade of the soil ball and the tree trunk portion or root collar of the tree is at least 50 mm

- higher to allow for settlement. For trees that have been budded or grafted, the visible joint area of the collar is to be 50 mm above the finished granular bed level.
- .2 Construct a soil ring around the edge of the planting pit to contain and direct water towards the root ball. The root ball shall be thoroughly saturated with water at the time of planting.
- .7 For groundcovers, backfill soil evenly to finish grade and tamp to eliminate air pockets.
- .8 Water plant material thoroughly after planting operations are complete.
- .9 After soil settlement has occurred, fill with soil to finish grade.
- .10 A qualified person shall conduct a structural prune as required to the satisfaction of the Urban Forester at the time of planting.
- .11 Dispose of burlap, wire and container material off site.
- 3.5 Tree Supports
- .1 Install tree supports unless indicated otherwise.
- .2 For deciduous trees 50 mm in diameter or greater:
- .1 Use double tree support.
- .2 For trees planted within the right of way, place one (1) stake in the direction of travel and the second opposite or as directed by the Engineer. For all other trees place one (1) stake on the prevailing wind side of the tree and second opposite or as directed by the Engineer. Both stakes are to be 800 mm minimum for trunk and should be placed on either side of the root ball. Where trees are planted next to driveways or walkways, place one (1) stake between the tree trunk and driveway or walkway.
- .3 Drive stakes minimum 300 mm into undisturbed soil beneath root ball. Confirm stakes are secure, vertical and un-split.
- .4 Install two (2) guying collars above lowest branch crotch a minimum 500 mm above grade.
- .5 Thread guying wire through collar tube. Twist wire to form collar and secure firmly to stake. Cut off excess wire. Confirm collar is minimum 25mm diameter larger than tree.
- .6 For trees larger than 100 mm in caliper, support trees with three-way guy wires and stakes positioned in the ground equidistant around the perimeter of the tree. Some larger trees will require additional guy wires for added support. The use of turnbuckles to maintain taut support on the support wires is recommended.

-
- .3 For evergreens, use three (3) guy wires:
 - .1 Install guying collars above branch to prevent slipping at approximately 2/3 height for evergreens. Collar mounting height not to exceed 1000 mm above grade.
 - .2 Guying collars to be of sufficient length to encircle tree plus 500 mm space for trunk clearance. Thread guy wire through collar encircling tree trunk and secure to lead wire by clamp or multi-wraps; cut wire ends close to wrap. Spread lead wires equally proportioned about trunk at 120 degrees.
 - .3 Install anchors at equal intervals about tree and away from trunk so that guy wire will form 45-degree angle with ground. Install anchor at angle to achieve maximum resistance for guy wire.
 - .4 Attach guy wire to anchors. Tension wire and secure by multi-wraps.
 - .5 Install wire tightner such that guys are secure and leave room for slight movements of tree.
 - .6 Saw tops off anchors, which extend in excess of 100mm above grade or as directed.

 - .4 After tree supports have been installed, prune and remove broken branches with clean, sharp tools.

 - .5 Staking and tethering shall be carried out as per the following requirements:
 - 1. Plants shall stand plumb after staking.
 - 2. The stems shall be attached loosely to the stakes to allow flexibility.
 - 3. Stakes (wood or metal) shall be driven firmly into the ground at a minimum of 40 cm depth.
 - 4. Place the stake into the outer edge of the planting hole, away from the root system but within the mulched planting area.
 - 5. Always use two stakes. If on the roadway, place stakes with the direction of travel.
 - 6. Tree tethers shall utilize the tree staking and tethering materials specified as follows:
 - i. All stakes shall be tethered to trees using means that allow for expansion of the tree and reducing the impacts of girdling and shall not be made of wire.
 - ii. Material in contact with the stem shall have a broad, smooth surface.
 - iii. Tethers shall be placed 2/3 the distance from the ground up to the first set of branches.

 - 3.6 Straightening .1 If straightening is required during the warranty period, it shall be carried out as per the following requirements:
 - .1 Straighten all trees that move out of plumb position. Trees to be straightened should be in good health.

- .2 If the tree cannot be straightened immediately, the root system shall be kept moist with irrigation and mulch.
- .3 Before straightening occurs, the soil shall be moist.
- .4 Trees to be straightened shall be excavated and the root ball moved to a plumb position, and then re-backfilled. Thoroughly water the tree and mulch the entire rooting area.
- .5 Do not straighten trees by pulling the trunk.

3.6 Mulching

- .1 Correct soil settlement prior to mulching.
- .2 Water plant material thoroughly prior to spreading mulch as indicated.
- .3 After installation of tree, shrub and groundcover plantings has been approved by the Engineer, place mulch around plants and spread to a depth of 75 mm for bark mulch and 115 mm for washed river rock mulch. Use weed-free fabrics below mulch only upon approval by Engineer.
- .4 Mulching for trees shall be carried out as per the following requirements:
 - .1 Bark mulch will be supplied by the contractor and shall be comprised of aged, shredded bark and wood chips or an acceptable industry alternative agreed upon by the Urban Forester.
 - .2 Bark mulch containing shredded wood shall be aged for one year minimum prior to installation.
 - .3 There must be sufficient mulch to cover the planting pit, flush with the surface of the ground.
 - .4 Mulch shall not be mounded/volcanoed at the base of the tree. Apply 5-10 cm of mulch before the mulch settles, covering the entire planting bed area.

3.7 Maintenance
During Establishment
Period

- .1 Perform following maintenance operations from time of planting to acceptance:
 - .1 Water to maintain soil moisture conditions for optimum establishment, growth and health of plant material without causing erosion.
 - .2 For evergreen plant material, water thoroughly in late fall prior to freeze-up to saturate soil around root system.
 - .3 Remove weeds monthly.
 - .4 Replace or re-spread damaged, missing, or disturbed mulch.
 - .5 Apply pesticides in accordance with federal, provincial and municipal regulations as and when required to control insects, fungus, and disease.
 - .6 Prune and remove dead or broken branches from plant material using proper pruning techniques.
 - .7 Keep stakes and guy wires in proper repair and adjustment.

-
- .8 Apply fertilizer in early spring at manufacturer's suggested rate and as required by planting material.
 - .9 Remove and replace dead plants and plants not in healthy growing condition. Make replacements in same manner as specified for original plantings.
 - .10 Where Municipal or Provincial Regulations prohibit the use of Federally and/or Provincially approved pesticides, and the available (alternative) non-pesticide controls are not acceptable to the Contractor, the application of pesticides to control insects, fungus and disease shall be deemed to be removed from this Section.
- .2 Watering for trees shall be carried out as per following requirements:
- .1 At the time of planting, the soil around each tree shall be thoroughly saturated with water. Water shall be free from oil and shall be free from impurities injurious to trees.
 - .2 All newly planted trees will be watered once per calendar week between spring (June 1) continuing through to the end of August for the first year unless greater than 20 mm of rain is received or forecast within that calendar week. With the Municipalities approval, adjustments may be made in watering frequency depending on soil type, weather, drainage, tree species, and weekly amounts of rainfall.
 - .3 The area in and around the planting site shall be watered slowly to allow enough time for the water to penetrate the soil to a depth of 15 to 30 cm and in such a fashion to ensure that water does not run away from the root zone.
 - .4 Water shall not be applied in a manner which damages trees, stakes, or adjacent areas.
 - .5 Proper watering shall not cause uprooting or exposure of tree's roots to the air.
- 3.8 Acceptance
- .1 Plant material will be accepted after planting operation is completed provided that plant material exhibits healthy growing conditions and is free from disease, insects and fungal organisms.
 - .2 Plant material installed in fall will be accepted in following spring, one month after start of growing season, provided acceptance conditions outlined in 3.9 below are fulfilled. The acceptance date, for material planted in the fall and accepted in the spring, will be deemed to be the date of the completion of fall planting operations.
- 3.9 Maintenance During Warranty Period
- .1 This maintenance will be the sole source of maintenance of the work during this period and is wholly the Contractor's responsibility. Should maintenance of the Work be removed from the Contract, warranty will cease following final acceptance at project completion.

-
- .2 From time of acceptance to end of warranty period, perform following maintenance operations:
 - .1 Water to maintain soil moisture conditions for optimum growth and health of plant material without causing erosion.
 - .2 For evergreen plant material: water thoroughly in late fall prior to freeze-up to saturate soil around root system.
 - .3 Re-form damaged soil and mulch ring.
 - .4 Remove weeds monthly.
 - .5 For non-mulched areas, cultivate monthly to keep top layer of soil friable.
 - .6 Apply pesticides where permitted in accordance with federal, provincial and municipal regulations as and when required to control insects, fungus and disease.
 - .7 Apply fertilizer in early spring at manufacturer's suggested rate and as required by plant material.
 - .8 Remove dead, broken or hazardous branches from plant material.
 - .9 Keep stakes and guy wires in proper repair and adjustment.
 - .10 Remove and replace dead plants and plants not in healthy growing condition. Make replacements in same manner as specified for original plantings.
 - .11 Notify Engineer or designated consultant when warranty period is completed to arrange inspection and transfer of maintenance responsibility to Owner.
 - .12 Remove tree supports at end of warranty period unless otherwise requested by the Engineer or Urban Forestry.

 - 3.10 Clean Up
 - .1 Remove surplus materials at no additional cost to the contract.

**** END SECTION 32 90 00 ****

PART 1 – GENERAL

- 1.1 Related Sections
- 1.2 Action and Informational Submittals
- 1.3 Delivery, Storage, and Handling
- 1.4 Warranty

PART 2 – PRODUCTS

- 2.1 Description
- 2.2 Materials

PART 3 – EXECUTION

- 3.1 General Conditions

PART 1 - GENERAL

| | | | | |
|-----|--|----|---|------------------|
| 1.1 | <u>Related Sections</u> | .1 | Concrete | Section 03 30 00 |
| | | .2 | Precast Concrete | Section 03 45 00 |
| | | .3 | Topsoil Placement and Grading | Section 32 91 19 |
| | | .4 | Trees, Shrubs and Groundcover Planting | Section 32 90 00 |
| 1.2 | <u>Action and Informational Submittals</u> | .1 | Submit in accordance with project Submittal Procedures | |
| | | .2 | Product Data: | |
| | | .1 | Submit manufacturer's instructions, printed product literature and data sheets for all composite elements of structural soil cell system and include product characteristics, performance criteria, physical size, finish, and limitations. | |
| | | .3 | Shop Drawings: | |
| | | .1 | Submit shop drawings to CSA A23.4 and CAN/CSA-A23.3 including: | |
| | | .2 | Manufacturer's site-specific soil cell layout in plan and section. Indicate on drawings: | |
| | | .1 | All composite elements of structural soil cell system. | |
| | | .2 | Construction details, material descriptions, finishes, installation details | |
| | | .3 | Methods of handling and erection. | |
| | | .4 | Grades and dimensions (indicate stepping or sloping conditions to achieve finished grades), and soil volumes as required. | |
| | | .5 | All details and drawings to be stamped by a Professional Engineer licensed in Nova Scotia | |
| | | .6 | Warranty the product satisfies all reasonably expected loading requirements in this location. | |
| | | .3 | Samples: | |
| | | .1 | Produce, deliver and erect where directed by Project Engineer on project site, [1] full size sample of each type of support module and related products finish and quality for approval of Project engineer. | |

- 1.3 Delivery, Storage, and Handling
- .1 Deliver, store and handle materials in accordance with Section 01 61 00 - Common Product Requirements.
 - .2 Delivery and Acceptance Requirements: deliver materials to site in original factory packaging, labelled with manufacturer's name and address.
 - .3 Storage and Handling Requirements:
 - .1 Store materials off ground and in accordance with manufacturer's recommendations in clean, dry, well-ventilated area.
 - .2 Replace defective or damaged materials with new.
- 1.4 Warranty
- .1 Provide manufacturer's standard warranty against defects in materials and workmanship.

PART 2 - PRODUCTS

- 2.1 Description
- .1 The Structural Soil Cell system shall have the flexibility to be assembled around existing structures, utilities and in tight constraints, specific to the site requirements and achieve the required soil and/or stormwater volume. The system shall be easily disassembled and reassembled to allow for utility repair within and below the system.
- 2.2 Materials
- .1 Either of the following systems:
 - a. StrataVault 30 series as manufactured by City Green Urban Landscape Solutions
Contact: Stephen Lovering
Email: stephen.lovering@citygreen.com
Telephone: 778-533-7764 Website: www.citygreen.com
 - b. Silvacell as manufactured by Deeproot Canada Corp.
Contact: Michael James
Email: mjames@deeproot.com
Telephone: 1 604-687-0899 Website: www.deeproot.com
 - .2 The Structural Soil cells system shall meet the manufacturer's specifications including, but not limited to, the following components:
 - a. non-woven filter cloth;
 - b. tensile geogrid;
 - c. root deflector, structural cells, and decking;
 - d. air and watering system;
 - e. Infill Panel: Injection molded, polypropylene or polyethylene with nominal dimensions as per manufacturer;

STRUCTURAL SOIL CELLS

JANUARY 2024

- f. Interlocking uprights and decks are assembled on-site to create modules which can be uniformly stacked in height, not to exceed 2m in height (per project design); and
- g. The soil module system shall have the ability to be assembled as a complete, interlocked unit or as independent modules.

PART 3 – Execution

- 3.1 General Conditions .1 Soil cells and related products shall be installed by a qualified installer with experience successfully installing structural soil cells on at least two (2) prior projects.
- Installer will be required to takes part in a training session provided by the manufacture. Training session to be attended by all foremen and key personnel involved in the installation.
 - Installer shall utilize the same field supervisor through the project unless a substitution is submitted and approved by the Engineer.
- .2 Coordinate the installation with the product manufacturer, to have the manufacturer on-site during product installation.
- Photo record of each phase of installation to be submitted to product manufacturer and Engineer.
- .3 Locate underground utilities before proceeding with excavation.
- Clearance and cover measurements for service pipes and conduits to be observed by installer.
- .4 Review manufacturer's installation procedures and coordinate installation with other work affected, such as grading, excavation, utilities, construction access, erosion control, etc.
- .5 Installation of the first 20m² section shall be completed and inspected by the Engineer or their representative.
- .6 Structural soil cells are not to be filled or covered prior to inspection and acceptance by the Engineer or their representative.
- .7 Each soil cell or stack of soil cells shall be structurally independent such that a single stack, or group of stacks, may be removed to facilitate future utility connections or repairs. If connections are required, the connections must have ability to break during access for maintenance or repair activities.

-
- .8 Cold weather installation or assembly of modules should not be undertaken when temperatures are below 4° C.
- .9 Tree Pit Layout: Layout tree pit locations and dimensions using string lines, survey pegs and marking paint. Obtain Engineer's approval of layout before proceeding with excavation.
- .10 Tree Pit Depths: Confirm excavation depths with reference to finished pavement elevations. Allow for granular base course layer and, where applicable, drainage layer.
- .11 Assembled modules may be walked on, but vehicular traffic is prohibited until properly backfilled and covered per Manufacturer's recommendations. Protect personnel and the installation against damage with highly visible construction tape, fencing, or other means until construction is complete.
- 3.2 Excavation Below Grade
- .1 Excavation required for the installation of all pipes and structures shall be made to the depths and widths indicated on the Drawings (a minimum of 300 mm beyond all sides of the structural soil cell components for proper backfill). The Contractor shall ensure that the bottom of the excavation is firm and dry and, in all respects, acceptable to the Engineer.
- .2 All objectionable material encountered within the limits indicated shall be removed and disposed of by the Contractor.
- .3 In excavation faces, all loose or protruding rocks shall be secured or otherwise removed to finished grade. All cut slopes shall be uniformly dressed to the slope, cross-section and alignment shown on the Drawings or as directed by the Engineer or authorized representative.
- .4 Furnish, install, monitor, and maintain excavation supports (e.g., shoring, sheeting, bracing, trench boxes, etc.) as required by to meet applicable safety requirements. Support the sides of excavation, to prevent any movement which could in any way reduce the width of the excavation below that necessary for proper construction and protect adjacent structures from undermining, settlement, or other damage.

| | | | |
|-----|--|----|---|
| 3.3 | Sub-Grade Preparation and <u>Grading</u> | .1 | Sub-grade shall be unfrozen, level, and free of lumps or debris with no standing water, mud, or muck. Do not use frozen materials or materials mixed or coated with ice or frost. A minimum 9,764.86 kilograms per square meter (2,000 pounds per square foot) bearing capacity is required. |
| | | .2 | If Contractor fails to maintain the sub-grade properly, the Contractor shall remove the unsuitable material. If the bottom of any portion of the excavation is removed below the limits shown on the Drawings, it shall be restored per the Engineer to the elevation shown in the Drawings. Compacted native earthen fill is not acceptable. |
| | | .3 | If in the opinion of Engineer or authorized representative, the sub-grade, at or below the normal grade of the excavation as indicated on the Drawings, is unsuitable for construction; it shall be removed to such depth and width as the Engineer may direct and be replaced with suitable material as directed by the Engineer or authorized representative. |
| 3.4 | Sub-Drainage Piping <u>Installation</u> | .1 | Install sub-drainage piping as per drawings. |
| | | .2 | Typically installed in the base layer. |
| 3.5 | Sub-Base <u>Preparation</u> | .1 | Install leveling bed to depths shown on drawings across the footprint of the structure. Granulars shall be rolled, or plate compacted to provide a flat surface; free from lumps, debris or any other sharp materials. Base may have up to a 5% slope. |
| | | .2 | Base shall be compacted to 95% Proctor Density minimum, or as specified by the Project Engineer. |
| | | .3 | Dependent on the geotechnical report, the Project Engineer or authorized representative may require that a reinforcement geogrid fabric be placed within the base layer. If required, the geogrid fabric shall have placed on top of 50 mm of aggregate and covered with 50 mm of aggregate. Overlap geogrid a minimum 300 mm, or as recommended by manufacturer. |
| 3.6 | <u>Installation of the Structural Soil Cells</u> | .1 | Installation procedure, as follows, shall be followed by the Contractor. The Contractor shall also reference the Manufacturer's Installation Guidelines, and where any discrepancy exists the Engineer reserves the right to contact the Manufacturer's Representative prior to continuation. |

STRUCTURAL SOIL CELLS

JANUARY 2024

-
- Installation constitutes acceptance of existing conditions and responsibility for satisfactory performance.
- .2 Utilize a soluble paint, chalk, or string to outline the footprint of the structural soil cell system. Prior to the installation of soil module panels, confirm tree pit dimensions and mark location of trees. Rectify discrepancies and errors. Ensure squareness prior to module placement.
- .3 Install structural soil cell modules in strict accordance with manufacturer's written instructions and installation diagrams. Prior to placement, check each soil module for damage. Reject cracked, chipped and otherwise damaged modules. Ensure that panels in contact with granular base course are firmly seated, with no rocking. Ensure that panels are mechanically interconnected both horizontally and, in multiple layers, vertically.
- .4 Upon completion of the placement, wrap the sides of the system with root and moisture barrier, or geogrid/fabric to prevent material migration into the soil module system. Avoid damage to the root and moisture or geogrid/fabric barrier during placement. If damage occurs, repair that portion per manufacturer specifications.
- 3.7 Utilities Within Soil Module System .1 Coordinate interface or spanning of utilities with the Project Engineer to ensure offsets module system meet utility owner's standards. This may require special treatments, barriers, and details.
- 3.8 Soil Filling .1 Obtain Engineer's approval prior to filling the structural soil cell modules with filler soil. Install filler soil after soil modules are fully assembled and piping systems and barriers are in place.
- .2 Except as shown otherwise on Drawings completely fill all void spaces with filler soil. Place filler soil using an excavator bucket and spread with rakes or shovels.
- .3 Keep outer trench free of filler soil.
- .4 Soil can be compacted in lifts of 200 mm to 300mm during placement and compacted by walking over layers or utilizing a hand-held roller designed specifically for this use. Note: the top panel is also an aeration deck allowing soil to be filled to top of upright panels.

- | | | | |
|------|---|----|--|
| 3.9 | <u>Aeration/Irrigation and Inspection Piping</u> | .1 | Horizontal Aeration/ Irrigation Piping: Place horizontal piping in accordance with soil cell manufacturer's specifications. <ul style="list-style-type: none">• Pipe to be placed level and wrap entire tree pit.• Perforations to face bottom of tree pit.• Connect pipe to irrigation port at surface. Port cover to have grate to allow aeration. |
| | | .2 | Horizontal Subdrain: 100mm dia. perforated pipe with filter sock. <ul style="list-style-type: none">• Install at low point in tree pit, connect to storm drain system. |
| 3.10 | <u>Root Barriers and Root and Moisture Barriers</u> | .1 | Install ribbed root barriers and root and moisture barriers per manufacturer specifications. Overlap barrier joints 200mm and tape both sides of joint. Top edge of barriers shall be level with adjacent construction. Ensure that earth surfaces in contact with barriers are flat and free of sharp debris and stones to avoid puncturing barriers. Install ribbed root barriers with ribs facing inward. |
| 3.11 | <u>Backfilling</u> | .1 | Place backfill materials around the perimeter in lifts with a maximum thickness of 300 mm. Each lift shall be placed around the entire perimeter such that each lift is no more than 600 mm higher than the side backfill along any other location on the perimeter of the structural soil cell system. No fill shall be placed over top of modules until the side backfill has been completed. |
| | | .2 | Each lift shall be compacted at the specified moisture content to a minimum of 95% of the Standard Proctor Density until no further densification is observed (for self-compacting stone materials). The side lifts must be compacted with walk-behind compaction equipment. Even when "self-compacting" backfill materials are selected; a walk behind vibratory compactor must be used. |
| | | .3 | Take care to ensure that the compaction process does not allow the machinery to come into contact with the structural soil cell system due to the potential for damage to the root and moisture barrier or geogrid/fabric and structural soil cells. |
| | | .4 | Continue backfilling the perimeter until it is backfilled within 300 mm of the top of the structural soil cells. |

| | | | |
|------|--------------------------------|----|--|
| 3.12 | <u>Installation of Geogrid</u> | .1 | Install the geogrid with integrated non-woven geotextile on top of the structural soil cell system allowing it to extend 300 mm vertical down the sides of the modules, and 300 mm horizontal away from the decking. Overlap geogrid with integrated non-woven geotextile a minimum 200 mm. |
| 3.13 | <u>Aggregate Base Course</u> | .1 | Continue backfilling the perimeter and top of the assembled modules in 150 mm lifts, until specified depth is reached. Each lift shall be compacted at the specified moisture content to a minimum of 95% of the Standard Proctor Density. |
| | | .2 | Ensure that all unrelated construction traffic is kept away from the limits of excavation until the project is complete and final surface materials are in place. No non-installation related loading should be allowed over the PAVEMENT SUPPORT SYSTEM until the final design section has been constructed (including pavement). |
| 3.14 | <u>Site Quality Control</u> | .1 | Compaction Tests: Testing agency shall perform compaction testing on sub-grade and on each layer of fill to determine compliance with specified compaction. Determine method and frequency of testing in consultation with Engineer. |
| | | .2 | Documentation: photos to be submitted to manufacturer and Engineer during each phase of installation. Work may not proceed until approval of previous phase has been provided. |
| 3.15 | <u>Tree Pit Openings</u> | .1 | Confirm exact location of tree pit openings. Cut geogrid layer and fold back to expose opening. Position perimeter formwork. |
| | | .2 | Line opening with root barrier where required with ribs facing inward. Extend root barrier down to top of soil modules and up to level of finished pavement. Lap root barrier joints 200mm and tape both sides of joint. |
| 3.18 | <u>Closeout Activities</u> | .1 | Provide manufacturer warranty, 20 year minimum. |
| 3.19 | <u>Cleaning</u> | .1 | Obtain approval of cleaning methods from Project Engineer before cleaning soiled precast concrete surfaces. |
| | | .2 | Final Cleaning: upon completion remove surplus materials, rubbish, tools, and equipment in accordance with Section 01 74 11 - Cleaning. |

- 3.20 Protection
- .1 Protect installed products and components from damage during construction.
 - .2 Repair damage to adjacent materials caused by concrete sidewalk and precast concrete curb installation.

****** END OF SECTION 32 94 50 ******

INDEX TO CLAUSES

PART 1 - GENERAL

- 1.1 Work Included
- 1.2 Related Sections
- 1.3 Reference Standards
- 1.4 Shop Drawings
- 1.5 Codes, Bylaws, Ordinances and Regulations
- 1.6 Certificates
- 1.7 Handling and Storage
- 1.8 Quality Assurance
- 1.9 Spare Parts

PART 2 - PRODUCTS

- 2.1 General
- 2.2 Concrete Bases
- 2.3 Conduits
- 2.4 Pull Pits and Junction Boxes
- 2.5 Transformer Bases
- 2.6 Traffic Signal Cables
- 2.7 Detection System
- 2.8 Poles, Mast Arms - Aluminum
- 2.9 Poles, Mast Arms - Steel
- 2.10 Signal Mounting Brackets
- 2.11 Traffic Signal Heads
- 2.12 Traffic Signal Backplates
- 2.13 Pedestrian Signal Heads
- 2.14 Pedestrian Push Buttons
- 2.15 Pre-Emption Devices
- 2.16 Pedestrian (RA-5) Signals
- 2.17 Rectangular Rapid Flashing Beacon (RRFB)
- 2.18 Uninterruptible Power Supply

PART 3 - EXECUTION

- 3.1 Excavation and Backfilling
- 3.2 Concrete Bases
- 3.3 Conduit Installation
- 3.4 Installation of Detector Loops
- 3.5 Installation of Transformer Bases, Poles and Mast Arms
- 3.6 Installation of Push Button Assemblies
- 3.7 Installation of Traffic Signals and Pedestrian Signals
- 3.8 Installation of Pedestrian (RA-5) Signals
- 3.9 Installation of Pre-emption Equipment
- 3.10 Wiring of Poles and Mast Arms
- 3.11 Mounting of Traffic Signal Controller Cabinet
- 3.12 Installation of Pedestrian (RA-5) Signal Controller
- 3.13 Removal and Disposal of Damaged and Obsolete Equipment
- 3.14 Grounding

PART 1 - GENERAL

| | | | | |
|-----|----------------------------|----|--|------------------|
| 1.1 | <u>Work Included</u> | .1 | This section specifies the requirements for the installation of traffic and pedestrian crossing signal systems. The Work consists of furnishing all labour, tools, and equipment, and performing all operations necessary to complete the installation of the traffic signal, pedestrian crossing items, UPS - Battery Backup, and any other supplementary systems as shown on the drawings. | |
| 1.2 | <u>Related Sections</u> | .1 | Concrete | Section 03 30 00 |
| | | .2 | Metal Fabrications | Section 05 50 00 |
| | | .3 | Earthwork | Section 31 20 00 |
| | | .4 | Walks, Curbs, and Gutters | Section 32 16 00 |
| | | .5 | Topsoiling and Finish Grading | Section 32 91 19 |
| | | .6 | Reinstatement | Section 32 98 00 |
| | | .7 | Hot Mix Asphalt Concrete | Section S-1 |
| | | .8 | Performance Graded Asphalt Binder | Section S-2 |
| 1.3 | <u>Reference Standards</u> | .1 | CSA C22.1 (latest edition), Canadian Electrical Code Part 1 | |
| | | .2 | International Municipal Signal Association (IMSA) Official Wire and Specifications Manual (latest edition) | |
| | | .3 | CSA C22.2 No. 211.2 (latest edition), Rigid PVC (Unplasticized) Conduit. | |
| | | .4 | CSA C22.2 No. 41 (latest edition), Grounding and Bonding. | |
| | | .5 | CSA C22.2 No. 85 (latest edition), Rigid PVC Boxes and Fittings. | |
| | | .6 | CSA S6 (latest edition), Canadian Highway Bridge Design Code. | |
| | | .7 | AASHTO LRFDLTS-1 (latest edition), LRFD Specifications for Structural Supports for Highway Signs, Luminaries and Traffic Signals. | |

- .8 ASTM C857 (latest edition), Standard Practice for Minimum Structural Design Loading for Underground Precast Concrete Utility Structures.
 - .9 ASTM D412 (latest edition), Standard Test Method for Vulcanized Rubber and Thermoplastic Elastomers – Tension.
 - .10 ASTM D2240 (latest edition), Standard Test Method for Rubber Property – Durometer Hardness.
 - .11 NEMA TS-2 (latest edition), Traffic Controller Assemblies with NTCIP Requirements.
 - .12 NEMA 250- (latest edition), Enclosures for Electrical Equipment (1000 Volts Maximum)
- 1.4 Shop Drawings
- .1 Submit shop drawings in accordance with Section 01 10 00.
 - .2 Submit shop drawings to HRM for review within 14 calendar days of tender award and order the materials within two (2) working days of receiving HRM’s shop drawing review.
- 1.5 Codes, Bylaws, Ordinances and Regulations
- .1 Perform all work covered by this section according to:
 - .1 Applicable Halifax Regional Municipality and Nova Scotia Power Incorporated (NSPI) Codes, Bylaws, Ordinances, and Regulations.
 - .2 Nova Scotia Department of Transportation and Infrastructure Renewal “Temporary Work Place Traffic Control Manual” (latest revision).
 - .3 HRM’s Traffic Control Manual Supplement.
 - .4 The Canadian Electrical Code.
- 1.6 Certificates
- .1 Submit manufacturer’s specification and test data that confirms proposed products and materials meet requirements of this Section in accordance with Section 01 10 00.
 - .2 Provide additional test data for any component specified herein as requested by the Engineer.
 - .3 Obtain final certificate of approval from NSPI.

- 1.7 Handling and Storage
- .1 Ship poles, mast arms, tenons, signal heads, and other equipment complete with all required hardware.
 - .2 Handle and store traffic signal system equipment in accordance with the manufacturer's written instructions and in a manner that avoids damage to the equipment. Should any item be damaged as a result of neglect or improper storage or handling, replace at no additional cost to the Contract to the satisfaction of the Engineer.
- 1.8 Quality Assurance
- .1 Have field work on traffic signal systems performed by or directly supervised by a journeyman electrician with a minimum International Municipal Signal Association (IMSA) Traffic Signals Level 1 Certification.
 - .2 In addition, have Traffic Signals work within the Control Cabinet and involving the Control Cabinet wiring and equipment performed by or directly supervised by a Licensed Journeyman Electrician with IMSA, Traffic Signals Level 2 Certification or an Electrical or Electronics Technician / Technologist with IMSA, Traffic Signals Level 2 Certification.
- 1.9 Spare Parts
- .1 Provide all unused portions of cable spools to the Owner at the conclusion of the Work.

PART 2 - PRODUCTS

- 2.1 General
- .1 All material and equipment supplied must be new unless otherwise stated.
 - .2 All traffic signal equipment must be compatible with HRM's existing traffic signal systems and must be approved by HRM prior to ordering.
 - .3 Provide equipment designed to meet or exceed wind loading requirements as set forth in the National Building Code for the HRM region.
 - .4 Supply all accessories and appurtenances for a fully functional traffic control system.
- 2.2 Concrete Bases
- .1 Cast in place base mix design to Section 03 30 00.

- 2.3 Conduits .1 Detector home runs: 38mm diameter rigid PVC: to CSA C22.2 No. 211.2.
- .2 Preformed Home-run detector loops: 19mm diameter rigid PVC, to CSA C22.2 No. 211.2.
- .3 Signal Cable: Rigid PVC to CSA C22.2 No. 211.2. Sizes shown on drawing.
- .4 Pole Risers: to Section 03 30 00, 20mm maximum aggregate size, minimum 35 MPA at 28 days, to sizes and dimensions shown on drawings.
- 2.4 Pull Pits and Junction Boxes .1 Pull pit: as per HRM standard drawing HRM 79.
- .2 Junction Box: (Above Ground): to CSA C22.2 No. 85, flanged, PVC junction box complete with fibre reinforced cover.
- .3 Junction Box: (In Concrete or in Ground): to ASTM C857.
- 2.5 Transformer Bases .1 Aluminum transformer base to AASHTO LRFDLTS-1, complete with hinged access door fastened with stainless steel hinges and screws. Bolt circles to match poles and bases.
- 2.6 Traffic Signal Cables .1 26-conductor traffic cable complete with PVC jacket. PE insulated and cabled symmetrical in layers with lay as per IMSA 19-1-1984. Tracers to be permanently marked or embedded into insulation not printed. Filler to be PVC or PE. Apply (1) one layer of tape under outside of jacket to lap at least 12.5% of tape width. Cable outside diameter not to exceed (1) one inch. 600 volt ac rating.
- .1 #10 stranded plain copper A.W.G. white.
- .2 #14 stranded plain copper A.W.G as follows:
- .1 Red: with (1) white tracer, Red with (2) white tracers, Red with (3) white tracers.
- .2 Orange: with (1) white tracer, orange with (2) white tracers, orange with (3) white tracers.
- .3 Blue: with (1) white tracer, blue with (2) white tracers, blue with (3) white tracers.
- .4 Black: with (1) white tracer, black with (2) white tracers, black with (3) white tracers.

- .5 Yellow: with (1) white tracer, yellow with (2) white tracers, yellow with (3) white tracers.
- .6 Brown: with (1) white tracer, brown with (2) White tracers, brown with (3) white tracers.
- .2 Five (5) conductor traffic cable complete with PVC jacket. PE insulated and cabled symmetrical in layers with lay as per I.M.S.A. 19-1-1984. Filler to be PVC or PE. Apply (1) one layer of tape under outside of jacket to lap at least 12.5% of tape width. Cable outside diameter not to exceed (1) one inch, 600 volt ac rating. Wire size and color coding is as follows:
 - .1 #14 stranded plain copper A.W.G as follows: "Red", "Orange", "Blue", "White", "Green".
- .3 (4) Four conductor traffic cable, PVC jacket. PE insulated and cabled symmetrical in layers with lay as per IMSA 19-1-84. Filler to be PVC. or PE. Apply one (1) layer of tape under the outside of jacket to lap at least 12.5% of tape width. Cable outside diameter not to exceed ½ inch. 600 volt ac rating. Wire size and color coding is as follows:
 - .1 #14 stranded plain copper A.W.G as follows: "Green", "White", "Black", "Yellow".
- 2.7 Detection System
 - .1 Inductive Detector Loops:
 - .1 Loop Cable: RWU 90, #14 AWG stranded bare copper conductor complete with cross-linked polyethylene insulation.
 - .2 Sealant: one-part, moisture curable, polyurethane sealant, self-levelling with the following minimum physical property ranges:
 - .1 Tensile Strength: 620 psi ± 43 psi to ASTM D412.
 - .2 Elongation: 290% ± 32% to ASTM D412.
 - .3 Minimum Hardness (Shore A): greater than 10 to ASTM D2240.
 - .3 In-ground Lead-in-Cable: 2-conductor, 14 AWG tinned copper, polyethylene insulation outer jacket and aluminum/polyester outer shield.
 - .4 Overhead Lead-in-Cable: 2 × 2 core with ground and foil shield complete with 5mm support wire.
 - .2 Preformed Detector Loops:
 - .1 Four (4) conductor, double-jacketed cable suitable for asphalt or concrete overlay.
 - .2 Conductors: #18 AWG with 0.5mm thick layer of crosslinked polyethylene (XLPE).

- .3 Void between conductors and inner jacket to be spiral wrapped in moisture resistant binder tape and filled with an amorphous water blocking gel.
 - .4 Inner jacket: 1.0mm crosslinked polyethylene (XLPE).
 - .5 Outer jacket: 0.9mm thick crosslinked polyethylene (XLPE). For direct buried applications employ an additional 5.0mm thick TPE insulated outer jacket.
 - .6 Lead-in cable: two (2) conductor, double jacketed cable, #16 AWG with a 0.5mm thick layer of crosslinked polyethylene (XLPE). Inner jacket and outer jacket to match specification above.
 - .7 Splices to be soldered, sealed and waterproofed.
- .3 Microwave radar detection:
- .1 Microwave based radar motion sensor to interface with traffic control cabinet (NEMA 170, 179 and 2070 cabinets). Capable of monitoring up to eight detection zones; motion detection range between 60-600 feet for cars, 160 feet for pedestrians and bicycles; complete with surge protection; powered from TCIB over Ethernet cables; mountable on corner pole or mast arm and capable of tracking up to 64 objects simultaneously.
- .4 Radar Detector:
- .1 Radar sensor matrix system capable of monitoring real time presence data complete with pre-assembled cabinet backplate and mounting hardware.
 - .2 Remotely accessible for traffic monitoring and sensor management.
 - .3 Integral surge protection.
 - .4 Watertight to NEMA 250.
 - .5 Accessories:
 - .1 Rack cards.
 - .2 Junction box.
 - .3 6-conductor cable.
- .5 Video monitoring equipment:
- .1 Camera:
 - .1 Single bell camera vehicle detection and counting, for highway counting and monitoring application.
 - .2 5MP CMOS, powered over Ethernet IP68, internally pressurized and leak tested, water tight to NEMA 250 and with an operable temperature range of -34°C to +74°C.

- .3 Resolution: 2560 x 1920 pixels
- .4 Lens: 180° Fisheye.
- .5 Power consumption: 5W nominal, 50W with heaters activated.
- .2 Processor:
 - .1 Vehicle tracking and counting, intersection actuation application, to NEMA TS2.
 - .2 TCP/IP communication.
 - .3 Wide Area Network (WAN) port for remote connectivity.
 - .4 Power: 120/240 VAC 50/60 H
 - .5 Power consumption: 35Wnominal, 85W with active camera heaters.
 - .6 Detector I/O: Twenty-four (24) optically isolated I/O, SDLC interface, or ITS interface.
 - .7 Outputs: 24 optically isolated outputs, SDLC interface conforming to TS2 specs, programmable up to 64 detectors.
 - .8 Operable temperature range of -34°C to +74°C.
- .3 Software: data interface, remotely operable with equipment, storage and retrieval of data. Proprietary software to matches the equipment system, Cloud backup enabled, capable of real time automatic alerts.
- 2.8 Poles, Mast Arms - Aluminum
 - .1 Round seamless tubes of aluminum alloy 6063-T6, free from longitudinal welds with No. 120 grit belt surface finish.
 - .2 Height, diameter, wall thickness, and taper: as indicated.
 - .3 Poles and arms to meet minimum loading requirements.
 - .4 Mast arms: aluminum alloy truss style complete with aluminum alloy 6063-T6 brackets, stainless steel nuts, bolts, and washers.
 - .5 Use anti-seize compound on all threaded hardware.
- 2.9 Poles, Mast Arms - Steel
 - .1 Steel poles and mast arms to be round in cross-section and have a constant linear taper of 1.17 cm/m. Shaft to be one piece with no circumferential welded splices.
 - .2 Tube seam welds for poles and mast arms must be free of cracks and excessive undercut, performed with an

automatic process with a smooth finish and have a minimum penetration of 60%. Seams within 100mm of a flange or base plate shall be 100% penetration. Poles to be fabricated to ASTM A572 or ASTM A595 Grade A with a minimum yield strength of 55 ksi.

- .3 Pole to include a 100mm x 250mm hand hole with the cover located 26mm to 153mm from pole base and arm base.
 - .4 All mast arms up to 15.2m in length are to be manufactured and shipped in one piece. Provide each arm with a cast end cap secured in place with set screws.
 - .5 Poles and arms to be designed in accordance with CSA S6 and must meet minimum loading requirements.
 - .6 Include anchor bolts with each pole, sized as determined by the fabricator. Use anti-seize compound on all threaded hardware.
 - .7 Fabricator to be certified to an AISC Fabricator Certified Quality Program.
 - .8 Treat field cuts and/or drill holes with cold galvanizing compound.
 - .9 Nuts to be double nutted and tightened to manufacturer's recommended torque.
- 2.10 Signal Mounting Brackets
- .1 Pole Mounted: 38mm diameter aluminum tubing and cast fittings unpainted unless specified on drawings.
 - .2 Mast Arms: 2-way variable tenon mount, with stainless steel hardware.
 - .3 Tenons: aluminum alloy complete with 201 stainless steel 19mm banding, buckles, pole plates, one way top bracket assembly, and one way bottom bracket assembly.
 - .4 Pole Plate: Double Band-it type MH/AL/100 by Pelco or approved equal.
 - .5 Color: as specified by Engineer.
- 2.11 Traffic Signal Heads
- .1 Housing: Polycarbonate with polycarbonate lenses and black visors unless otherwise specified on the drawings.

- .2 Color: Yellow housing unless otherwise specified on the drawings.
- .3 Lamps: All signals to have 300mm LED modules built to the latest ITE specifications
- .4 Complete with snow shield.
 - .1 Acceptable product: Snow Sentry.

- 2.12 Traffic Signal Backplate
 - .1 Primary Signal Heads to come complete with yellow Polycarbonate reflectorized backplate non-louvered, with 76mm 3M diamond grade reflective white tape border.

- 2.13 Pedestrian Signal Heads
 - .1 Housing: Bi-modal polycarbonate housing.
 - .2 Color: Yellow housing and black visors unless otherwise specified on the drawings.
 - .3 Lamps: All pedestrian signals to have Square LED modules built to the latest ITE specifications.
 - .4 Countdown Pedestrian Signal Heads as shown on the drawings.
 - .5 Symbols: to the International Municipal Signal Association (IMSA) Official Wire and Specifications Manual (latest edition).

- 2.14 Pedestrian Push Buttons
 - .1 Pedestrian push buttons:
 - .1 Audible signal with accompanying visual one. Wireless Bluetooth communication, 360 degree dual-side speaker output, over-mold board protection, APS connectivity accessibility, and tested to NEMA TS2 for temperature, humidity, mechanical shock vibration and transient surge.
 - .1 Acceptable Product: Polara i-Navigator APS, Model iN-2 for existing systems, Model iN3 for new systems; or approved equivalent.
 - .2 Sounds: As per latest recommendation by the Canadian National Institute for the Blind as confirmed by the Engineer.
 - .3 Colour: Yellow or as specified.

- 2.15 Pre-Emption Devices .1 Plug-in, four (4) channel, dual priority, multimode encoded signal device for use with GPS radio/GPS intersection equipment.
- .2 Capable of reading three (3) distinct emitter frequencies, high priority, low priority and probe priority.
- 2.16 Pedestrian (RA-5) Signals .1 Type: Double-sided illuminated 600mm × 750mm RA-5 Crosswalk sign with walking man symbol inside white border, complete with 300mm flashing amber beacons attached to each side of sign if specified.
- .2 Body:
- .1 Aluminum, treated to prevent premature peeling and blistering using interprime 5519 etch primer and 519 converter prior to painting. Sign to be painted 514 crosswalk yellow.
- .2 All seams to be welded in main body construction.
- .3 Bottom of sign to have an opening protected by wire mesh.
- .4 No exposed wiring inside sign except for terminal ends in bottom.
- .5 Stainless steel hinges with removable pins to hold both door faces of sign to main sign, and stainless latch to close door faces to main sign. Doors to swing upwards freely with no obstructions.
- .6 CSA labeled.
- .7 Wiring diagram with completed parts list.
- .8 RA-5 housing to be a maximum of 660mm W x 790mm L x 320mm D.
- .3 Lens:
- .1 Lexan 5mm thick, slide in-slide out, replacement.
- .2 Facelight source to be LED 120/130 volt 40w lamp, mogul base (lamp to be included). Ballast to be mounted in plate with quick detachable socket for wiring.
- .3 Down light source to be LED 120/130 volt 54w lamp, mogul base (lamp to be included). Mount ballast in plate with quick detachable socket for wiring. Down light source to provide illumination of 43 lux on the roadway surface.
- .4 Switch inside to provide disconnect to lamp socket.

- .4 Mounting:
 - .1 Mast Arm: top of fixture to be reinforced with minimum 7mm aluminum plate to absorb strain of the hanger. Supply cushion hanger with sign. Supply safety chains and eye bolts on top to prevent signs from rotating in high winds. Doors to swing upwards freely with no obstructions.
 - .2 Span Wire: top of fixture to be reinforced with minimum 7mm aluminum plate. Provide double span wire suspension hangers with wire entrance port complete with wire clamp and protector. Bottom suspension wire to be clamped with suitable clamping device capable of supporting total weight of signs in the event of primary messenger failure.
- .5 Beacons: Each sign to be complete with two (2) 300mm flashing amber LED beacons in yellow polycarbonate housing, one attached to each side of the sign (right side: facing the viewer; left side: facing away from the viewer). Black visors unless otherwise specified on the drawings.
- .6 Complete sign assembly to be CSA certified.
- .7 Pedestrian controller:
 - .1 Controller to be capable of activating the pedestrian signals for a programmable length of time.
 - .2 Any press of the push buttons must be capable of starting the crossing countdown over.
- 2.17 Rectangular Rapid Flashing Beacon (RRFB)
 - .1 Overview: The RRFB shall conform to all provisions of the MUTCD, Interim Approval IA-21 including flash pattern.
 - .2 An AC-powered version and solar powered version shall be available. (see drawings for type required)
 - .3 Mechanical Specifications:
 - .1 For top of pole mounting, the solar panel shall be supplied with a fixed tilt angle of 45 degrees and shall be able to be oriented toward the equator with no additional mounting hardware.
 - .2 For side of pole mounting, the solar panel shall be supplied with an adjustable tilt angle and shall be able to be oriented toward the equator with no additional mounting hardware. Solar simulations for side-of-pole solar panel mounting shall assume 45-degree angle.
 - .4 Fasteners shall be stainless steel.

- .5 Light bar - Each RRFB shall include from one to four light bars as required.
- .1 The light bars shall be current-driven LEDs
 - .2 The light bar housing shall be constructed from aluminum and shall have the approximate dimensions: 24" L x 1.5" D x 4.5" H (61.0 cm L x 3.8 cm D x 11.4 cm H).
 - .3 Each light bar shall conform to all provisions of the MUTCD and FHWA requirements.
 - .4 Each of the two modules in a light bar shall have 8 LEDs and shall be purpose-built by the manufacturer of the RRFB including the optics. The optics shall be premium, UV-resistant polycarbonate.
 - .5 Each end of a light bar shall include a side-emitting pedestrian confirmation light composed of a single LED. Users shall have the option of using both confirmation lights for median applications, or covering one confirmation light with an included sticker for side-of-road applications.
 - .6 The light bar shall be mounted to the post or pole using a separate bracket assembly to facilitate mounting two light bars back-to-back (bi-directional) and to allow the light bar(s) to rotate horizontally for aiming.
- .6 Mounting adapter hardware for the RRFB cabinet shall be available for 4" – 4.5" round poles or square posts. Manufacturer shall provide a 5-Year Limited Warranty.
- .7 The User Interface shall provide viewing and/or programming access for the following:
- Activation Duration (5 to 60, 60 to 1200, or 3600 seconds)
 - Digital output that is active during the flashing cycle that allows the control of external devices such as crosswalk illumination. Digital output shall be configurable for night operation only or operation day or night
 - Radio Channel (Choice of 1 to 14)
 - Radio Status
 - Night Intensity Setting
 - Adjustment for Ambient Daytime Brightness
 - Self-Test / BIST (Built-In Self-Test) including the detection of shorts or open circuits in the fixture outputs
 - Battery Status – General description and actual battery voltage

- Day or Night Status (as determined by dedicated photosensor not solar panel output)
 - Solar Panel Voltage
 - Automatic Light Control. If this safety feature is enabled, it allows the RRFB to temporarily reduce the intensity of the light bars to maintain energy equilibrium. The user interface shall report the amount of dimming being applied in the range of 10% to 100%
 - Daily activations averaged over 90 days
 - Pushbutton detection
 - Firmware Version number
- .8 A detailed solar simulations shall be provided as evidence that the RRFB is capable of the claimed performance at a specific location. Solar Simulations shall be composed of three calculations: Energy Balance, Array-to-Load Ratio (ALR), and Autonomy. The manufacturer or bidder shall provide a detailed analysis of these three calculations in an "Energy Balance Report".
- .9 The Manufacturer shall be ISO 9001 certified.
- .10 Acceptable product: Carmanah Technologies Inc.
- 2.18 Uninterruptible Power Supply
- .1 UPS - Battery Backup Systems (BBS) for Traffic Signals.
- .2 Compatibility: BBS to be compatible with the traffic controller cabinet, controller and cabinet components, including the safety monitor, for full time operation. BBS to include all necessary cables to connect Inverter/Controller and battery panel(s).
- .3 Run-time: BBS to provide a 2-amp cabinet load a minimum run-time of four (4) hours of full color operation.
- .4 Output Capacity: BBS to provide a minimum of 1000W @ +74°C, continuous active output capacity, with a 90% minimum inverter efficiency while running in battery backup mode.
- .5 Output Voltage: When under battery power, BBS output voltage to be 120 VAC, pure sine wave output, ±3%, 60 Hz ±0.1%.
- .6 Transfer Time: The maximum transfer time allowed, from disruption of utility line voltage to stabilized inverter line

voltage from batteries shall be eight (8) milliseconds. The maximum transfer time when switching from inverter line voltage to utility line voltage after the line-qualifying period shall be ten (10) milliseconds. The BBS must be capable of allowing the user to change the transfer time in eight (8) millisecond increments up to 200 milliseconds if needed by the cabinet equipment.

- .7 Operating Environment: The operating temperature for the Inverter/Controller, Battery Hub and Power Interface Module (PIM) shall be -35°F to +165°F (-37°C to +74°C).
- .8 Surge Protection: BBS transient protection to be able to handle a minimum of 480 joules of energy and 39kA peak current. In addition, input circuit to contain an RF filter, which provides attenuation of line noise of 25 dB at 10 KHz, 65 dB at 100 KHz and 100 dB at 1 MHz.
- .9 Power & Control Connections: BBS to have the capability to be replaced with ease utilizing single connectors for AC input, AC output and the battery panel(s).
 - .1 AC Connection: AC input and output to be separate panel mounted plug/receptacles that allow no possibility of accidental exposure to dangerous voltages. Plug/receptacles to utilize some form of locking mechanism to prevent accidental disconnect.
 - .2 Battery Connection: battery panel to utilize a single circular barrel type connector for connecting to the Inverter/Controller with ease.
- .10 Battery: sealed Nickel-Zinc (NiZn) battery technology. Lead-Acid battery technologies will not be accepted.
 - .1 Charging/battery monitoring circuitry to be incorporated within the battery panel.
 - .2 BBS to allow the user to 'Hot Swap' the battery panel(s) while on utility power or battery backup power.
 - .3 The Inverter/Controller must allow the connection of four (4) battery panels directly to the Inverter/Controller.
 - .4 The Inverter/Controller must be capable of accepting battery panel(s) of different capacities at once, giving the user the ability to utilize different battery sizes to achieve required run-times.
 - .5 Inverter/Controller to accept up to sixteen (16) battery panels when utilizing a battery HUB(s).

- .11 Charge Time: The BBS must recharge to full charge capacity within four (4) hours of complete discharge when AC utility line voltage is available. The number of battery panels connected to the Inverter/Controller shall have NO effect on the four (4) hour recharge time. Temperatures below 149°F (65°C) shall not have any effect on the ability to recharge or the recharge time. The BBS must not require trickle/float charging.
- .12 Unit Failure: The BBS must have a fail-safe utility tie feature that automatically cuts back to the utility line in the event of an Inverter/Controller failure, battery panel(s) failure or complete battery panel(s) discharge.
- .13 LCD Display: BBS Inverter/Controller to have a 4 line by 20-character LCD display with an LED back light. From the main screen, LCD display to provide the following information:
 - .1 Utility line voltage
 - .2 BBS status
 - .3 Cabinet current consumption
 - .4 Battery charge percentage
 - .5 Available backup time in hours and minutes
- .14 Keypad: BBS Inverter/Controller to include a 4-way navigational keypad to allow users the ability to navigate the menu and program user set parameters.
- .15 Programmable Relays: BBS Inverter/Controller to include eight (8) programmable relays, which are controlled by power line conditions, and user selected settings of the BBS. These relay contacts shall be rated for 2 amps @ 120 VAC. Each relay shall have the ability to be triggered by multiple conditions simultaneously. The programming options are as follows:
 - .1 Loss of utility line voltage
 - .2 Low battery
 - .3 Time of day
 - .4 Temperature
 - .5 Time delay (for red flash)
- .16 Event Log: BBS to provide an event log, which will allow the user to view the date, time, and duration of a given event. The event log shall provide the user with an image of the waveform from the given event. Data to be recorded in a FIFO format so the oldest event is purged as the newest is entered.

- .17 Manual Bypass Switch: BBS Inverter/Controller to include a manual bypass switch to allow the user to manually bypass the inverter while allowing the utility line voltage through to the cabinet.
- .18 Circuit Breakers: Equip the BBS Inverter/Controller with two (2) 20A circuit breakers, one (1) each for the AC input and output.
- .19 Force On: Equip the BBS with "Force On" capabilities, which provides the user the ability to turn the BBS on and supply backup power when no utility line voltage is available. This allows the user the ability to install a BBS and provide backup AC power at an intersection that has no utility line voltage available.
- .20 Communication:
 - .1 The BBS must have the capability to provide Ethernet and IP addressing communications with the capability for remote monitoring and programming. This capability must be provided through a desktop application.
 - .2 Equip BBS with an Ethernet port. Ethernet port to be an RJ45, EIA 568B pin out type connector. Data rate to be 100mbps.
- .21 Warranty: provide a warranty for the complete system including battery panel(s) that expressly states the system will be free from defects in material and workmanship for a minimum of five (5) years from the date of original receipt.
- .22 Enclosure:
 - .1 Contain all Batteries, UPS unit and additional equipment in a weather proof aluminum enclosure.
 - .2 Engineered to accommodate outdoor powering equipment in pole or wall mount configurations. Durable, outdoor design kiosk, CSA approved, NEMA 3R weather resistant UPS enclosure.
 - .3 All aluminum welded construction and durable powder coat finish provides superior corrosion resistance.
 - .4 Sliding battery trays with lock-in/lock-out features standard. A variety of configurations available to support specific powering needs. Portable generator cabling access panel.
 - .5 Single or multiple power supply enclosure to support distributed powering architectures. The power

- .6 supply is located on the equipment shelf above the batteries for maximum convection cooling. Includes a removable lockable door and easy opening lid, high magnetic circuit breaker and a duplex AC receptacle.
- .7 Dimensions: 762mm W x 1219mm H x 457mm D unless otherwise specified.

PART 3 - EXECUTION

- 3.1 Excavation and Backfilling
 - .1 Do excavation and backfilling in accordance with Section 31 20 00 – Earthwork.

- 3.2 Concrete Bases
 - .1 Do cast in place concrete in accordance with Section 03 30 00 – Concrete.
 - .2 Confirm, through survey review, the locates of underground infrastructure and review overhead wire routing prior to excavation to avoid conflicts or obstructions and achieve required offsets.
 - .3 Protect concrete bases and poles until project completion.
 - .4 Install a vertical post or pole (metal or wooden) to a height of at least 2 m, within 3 business days of base installation and keep in place until final pole installation.

- 3.3 Conduit Installation
 - .1 Location, number, and size of conduit as indicated on drawings or as directed by Engineer.
 - .2 Do cast in place concrete in accordance with Section 03 30 00 – Concrete.
 - .3 Obtain permits from NSPI.
 - .4 Install non-concrete encased conduit in accordance with standard drawing number HRM 78.
 - .5 Install concrete encased conduit in accordance with detail indicated on the drawings.
 - .6 Use wood forms for concrete encased conduit rather than place concrete in direct contact with the sides of excavation.

- .7 Join conduit in accordance with manufacturer's instructions. Ream the ends of all conduit to ensure smooth interior finish that will not damage the insulation of the wires.
- .8 Protect conduit stubs from construction related damage with caps to prevent entrance of foreign materials.
- .9 Confirm conduit stubs are located correctly and terminations are suitable for installation of equipment.
- .10 Provide complete connections between conduit ends and terminal boxes of electrically operated equipment.
- .11 Remove all water and foreign material from conduit and raceways by swabbing out the conduit or by using compressed air.
- .12 Draw conductors and/or wire, and pull string through conduit. Use approved lubricants for drawing conductors through conduit. Leave at least one metre of slack in each conductor at panel boards, outlet boxes, and other devices to facilitate the making of joints.
- .13 Cover all non-concrete encased conduit along entire length with 38mm x 140mm treated wood plank. Plank to be pressure treated with pentachlorophenol to retention of at least 3.6 kg as per CSA S6 and CSA 080.
- .14 Place electrical underground warning tape above the conduit 150mm to 250mm below finished grade. Warning tape shall be 0.9mm thick, 150mm wide, and made of heavy duty polyethylene material with over-coated graphics. Red with black text that reads: 'CAUTION BURIED ELECTRIC LINE BELOW'.
- .15 Install concrete pole riser to cover pipes that run to the surface on all wooden poles as per HRM standard drawing HRM 86. Dowel riser into pole using stainless steel bolts. Use anti-seize compound on all threaded hardware. A metal guard to a height of 2.5m plus expansion joint can be used in place of the concrete pole riser on a wooden pole with single conduit run.
- .16 Leave pull wire in each empty duct. Fasten pull string to end of conduit with duct tape.
- .17 Have conduit inspected and approved by the Engineer prior to backfilling.

- .18 Backfill in accordance with Section 31 20 00 – Earthwork. Carry out surface reinstatement in accordance to Section 32 98 00 – Reinstatement.
- 3.4 Installation of Detector Loops
- .1 Locations and dimensions indicated on drawings are approximate.
- .2 Final locations and dimensions to be approved by Engineer prior to saw cutting asphalt.
- .3 Unless otherwise directed, saw cut an 10mm wide slot in pavement to a uniform depth between 50mm and 75mm.
- .4 Prior to laying the loop wire, ensure that the slots are clean with no sharp corners which could damage the loop wire. Remove chips and moisture using dry air at a pressure of at least 900 kPa. A heat wand may be used to dry the saw cut.
- .5 Lay loop wire in one continuous length of wire around the saw cut as per the drawings or as directed by the Engineer. Loop wire to be continuous from junction box at the curb around the loop and back to the curb. No splices are permitted in this section of wiring.
- .6 Number of turns as directed by the Engineer.
- .7 Tag or label clearly with permanent ink, loop lead in-cable at controller to indicate assigned phase and function, and top and bottom of loop.
- .8 Place sealant in saw cut in accordance with detector loop sealant manufacturer's recommendation.
- .9 Gain access to curbside junction box by saw cutting curb from street side to back of curb. Saw cuts to be of sufficient depth to provide a minimum depth of 38mm to 50mm cover over loop wires.
- .10 Tightly twist loop wires, from the saw cut to the curb side junction box, at a rate of least 15 turns per metre.
- .11 Seal curb and saw cuts using detector loop sealant. Confirm no voids are formed between saw cut, loop wire, and sealant when sealant is being applied.

-
- .12 Solder splice between detector loop cable and detector lead-in cable in junction box. Protect splice point with moisture proof seal.
- .13 Loop Testing:
- .1 Conduct loop insulation test with 500 volt Megger from loop lead-in to earth ground. Obtain a reading of 100 megohm or greater.
 - .2 Conduct loop continuity test at loop lead-in cable termination ends. Obtain a resistance of 5 ohms or less.
 - .3 Provide test results to the Engineer.
- .14 Loop tails to cabinet termination ends longer than 23 metres require shielded lead-in cable.
- .15 Where lead-in cable must be longer than planned, the loop inductance must be equal to or greater than that of the lead-in cable. Loop inductance less than that of the lead-in cable will be considered unacceptable.
- 3.5 Installation of Transformer Bases Poles and Mast Arms
- .1 Secure transformer base to concrete base anchor bolts using galvanized nuts and manufacturer-approved washers 10mm and 13mm thick at top of transformer base. Tighten nuts and torque an equal amount in accordance with the manufacturer's recommendations. Provide a vertical post (metal or wood), minimum 2.0m high, on all bases that do not have a pole.
 - .2 Confirm poles are installed and secured to a vertical alignment.
 - .3 Install mast arms and other required fixtures once pole is plumbed and secured.
 - .4 Install transformer bases flush with the concrete base. Do not install nuts between the transformer base and the concrete base.
 - .5 Use anti-seize compound on all threaded hardware.
- 3.6 Installation of Push Button Assemblies
- .1 Aluminum and Steel Poles:
 - .1 Drill and tap pole prior to installation.
 - .2 Confirm contact points between push button and pole face are silicon sealed.

- .3 Ream apertures through pole to provide smooth interior finish, remove all sharp edges and prevent damage to the insulation of the wires.
 - .4 Drill drain hole in bottom of push button.
 - .5 Mounting bolts to be stainless steel. Use anti-seize compound on all bolts.
 - .2 Wood Poles:
 - .1 Attach push button assembly to pole using a #10 x 50mm Robinson head stainless steel screw.
 - .2 Install wiring through bottom of push button using liquid tight flex or conduit to prevent condensation or leakage from shorting out the actuator. Drain hole added to the low point of the flex for drainage.
 - .3 Confirm contact points between push button and pole face are silicon sealed.
- 3.7 Installation of Traffic Signals and Pedestrian Signals
 - .1 Install traffic signal heads using mounting specified or as directed by Engineer. Provide aluminum mountings with hub plates, cast nipples, nuts, bolts, and fitting caps.
 - .2 Seal wire nut connections with professional grade vinyl electrical tape. Bundle off and tie wrap with wire nuts forming a cap and store bundle high up in traffic signal to minimize water damage to the wire nut connections. Do not use terminal strips in signal heads.
 - .3 Use anti-seize compound on all threaded connections.
 - .4 For horizontal signal heads, hinges to be on top for doors to swing upward.
- 3.8 Installation of Pedestrian (RA-5) Signals
 - .1 Install RA-5 sign as per manufacturer's directions. Test photocell flashing beacon, and fixture light after installation.
- 3.9 Installation of Pre-emption Equipment
 - .1 Install and test traffic pre-emption equipment and accessories as Per manufacturer's directions. Provide all necessary wiring for pre-emption equipment to ensure proper operation of system. No splices are permitted.
 - .2 Test detectors using tester provided by the Engineer. Provide test results to the Engineer.

- 3.10 Wiring of Poles, and Mast Arms
- .1 Keep wire connections to a minimum, both in junction boxes and transformer bases. The use of pull pits for wire connections will not be permitted. Break out of the cable only those wires that are required, leaving unused wires uncut.
 - .2 Seal wire nut connections with professional grade vinyl electrical tape. Bundle off and tie wrap with wire nuts forming a cap and store bundle high up in transformer base to minimize water damage to wire nut connections.
 - .3 Install multi-conductor cable (#14 AWG stranded copper wire) from each signal head location through mast arm and the pole aperture, down through pole to the centre of the access door in the transformer base. Wire to be appropriate number of conductors for each application.
 - .4 Provide an additional 600mm of cable run for connection.
 - .5 Continue multi-connector cable run to controller and leave 1200mm additional cable.
 - .6 Provide drip loop where cable enters the pole from the bracket.
 - .7 Connect conductors in signal heads to wire nuts. Tape individually and face joints upwards in each head. Leave spare conductors full length, coiled and end terminated by folding back the last 150mm of the conductors with insulating tape.
 - .8 Ground all metal equipment to ground terminal in base using separate ground wire.
 - .9 Make final connections. Test the wiring and provide written results to Engineer in duplicate. Obtain approval from Engineer for finished work.
 - .10 Hot test all signals in the presence of the Engineer.
 - .11 Label each wire indicating appropriate signal head at pole base.
- 3.11 Mounting of Traffic Signal Controller Cabinet
- .1 Install cabinet on base. If cabinet is to be fastened to a pole, use 19mm stainless steel band-it strapping.

- .2 Seal cabinet to concrete base, using rubber gasket and silicone between cabinet and concrete base. Trim gasket to be flush with cabinet.
- .3 Connect traffic signal field wires to cabinet field terminals. Test to confirm operation as per wiring diagram and as directed by the Engineer.
- .4 Contractor to connect detector loop and pre-emption device wires to cabinet as per wiring diagram and as directed by the Engineer.
- 3.12 Installation of Pedestrian (RA-5) Signal Controller
- .1 Install controller cabinet in accordance with manufacturers directions.
- .2 If cabinet is to be fastened to a pole, use 19mm stainless steel band-it strapping.
- 3.13 Removal and Disposal of Damaged or Obsolete Equipment
- .1 Dispose of hazardous material in accordance with all applicable laws including the Environmental Protection Act.
- .2 If requested by the Engineer, return traffic signal equipment and wires to HRM. Disassemble and handle with care all traffic signal equipment to be returned to HRM.
- .3 When upgrading a traffic signal system, dismantle and remove abandoned traffic signal infrastructure from site.
- 3.14 Grounding
- .1 Ground equipment in accordance with CSA C22.2 No. 41
- .2 Ground each pole and transformer base back to the ground rod or plate and bring the grounding wire back to the ground at the power source and not to the controller.
- .3 Ground the traffic Signal Controller separately from all other equipment to a ground rod at the cabinet location and run back to the service ground.

**** END SECTION 34 41 13 ****

INDEX

For Halifax Water Standard Details, see Halifax Regional Water Commission Supplementary Standard Specifications Section 39 00 00 – Standard Details, latest edition

| <u>TITLE</u> | <u>DETAIL No.</u> | <u>Date</u> |
|---|--------------------------|--------------------|
| Asphalt Swale | HRM 30 | 2021 |
| Speed Hump | HRM 31 | 2023 |
| Driveway Deflection Angles & Grades | HRM 32 | 2021 |
| Guide Rail Installation | HRM 36 | 2021 |
| Railing | HRM 37 | 2021 |
| Urban Traffic Sign Post | HRM 38 | 2023 |
| Rural Traffic Sign Post | HRM 39 | 2023 |
| Typical Walkway | HRM 40 | 2021 |
| Active Transportation Off Road Trail | HRM 41 | 2021 |
| Urban Sidewalk | HRM 44 | 2021 |
| Rural Type I Sidewalk | HRM 45 | 2021 |
| Rural Type II Sidewalk | HRM 46 | 2021 |
| Rural Type III Sidewalk | HRM 47 | 2021 |
| Concrete Sidewalk Reinforcing | HRM 48 | 2023 |
| Pedestrian Ramp Alignment | HRM 49 | 2021 |
| Driveway Ramp | HRM 50 | 2021 |
| New Driveway Access in Existing Full-Depth Curb | HRM 51 | 2021 |
| Concrete Traffic Island | HRM 52 | 2021 |
| Concrete Curb & Gutter | HRM 53 | 2021 |
| Curb Renewal / Payment | HRM 54 | 2021 |
| Asphalt Curb | HRM 55 | 2021 |
| Concrete Bus Bay Pad - End Block | HRM 57 | 2024 |
| Concrete Bus Bay Pad - Mid Block | HRM 58 | 2024 |
| Trench Backfill and Reinstatement Testing | HRM 61 | 2021 |
| Tree Planting in Parks/Open Space | HRM 66 | 2021 |
| Underground Conduit | HRM 78 | 2021 |
| Pull Pit | HRM 79 | 2021 |
| Wooden Pole Power Feed (For Traffic Signals) | HRM 86 | 2021 |

| | | |
|--|---------|------|
| Aluminium Pole RA-5 Signal Configuration | HRM 87 | 2021 |
| Wooden Pole RA-5 Traffic Signal With Power Feed Configuration | HRM 88 | 2021 |
| Standard Intersection Pavement Marking Layout | HRM 89 | 2021 |
| Longitudinal and Transverse Markings | HRM 90 | 2021 |
| Pavement Arrows | HRM 91 | 2021 |
| Bicycle Symbol & Shared Use Lane Symbol | HRM 92 | 2023 |
| Pedestrian Gate | HRM 119 | 2023 |
| Urban Traffic Sign Installation | HRM 129 | 2024 |
| Rural Traffic Sign Installation | HRM 130 | 2024 |
| Tactile Walking Surface Indicator Ramp Placement | HRM 131 | 2023 |
| Walkway with Pedestrian Ramp | HRM 132 | 2021 |
| Concrete Sidewalk Adjacent Curb | HRM 133 | 2021 |
| Red In-Lay Reserved Lane | HRM 134 | 2021 |
| Fence Detail (Round Wooden Rails & Steel Posts) | HRM 135 | 2021 |
| Speed Hump Survey Verifications | HRM 136 | 2021 |
| Concrete Bus Stop Landing Pad (With Sidewalk) | HRM 138 | 2024 |
| Tree Protection Zone & Barrier | HRM 140 | 2021 |
| Speed Table Detail | HRM 143 | 2023 |
| Speed Table Survey Verification | HRM 144 | 2021 |
| Bus Stop Shelter on Concrete Sidewalk | HRM 153 | 2024 |
| Bus Stop Shelter on Concrete Wall | HRM 155 | 2024 |
| Bus Stop Shelter on Concrete Sono-Tubes | HRM 156 | 2024 |
| Utility Pole Service Detail | HRM 160 | 2021 |
| Inverted U Bike Rack | HRM 165 | 2021 |
| Multi Inverted U Bike Rack | HRM 166 | 2021 |
| Post & Ring Bike Rack | HRM 167 | 2021 |
| Rectangular Rapid Flashing Beacon (Solar Cabinet-Based) | HRM 172 | 2023 |
| Rectangular Rapid Flashing Beacon (Solar Self-Contained) | HRM 180 | 2023 |
| Soil Texture Triangle | HRM 181 | 2021 |
| Tree Planting in SOD Boulevard | HRM 182 | 2021 |
| Accessible Parallel Parking (Beginning Of Block) | HRM 193 | 2024 |
| Accessible Parallel Parking (Midblock & End of Block) | HRM 194 | 2023 |

Traffic Signal Bases

| | | |
|---|-----------|------|
| Traffic Signal Base for Configuration A | HRM 68 | 2021 |
| Standard Notes – Shaft Foundations | HRM 68N1 | 2021 |
| Standard Notes – Spread Footings | HRM 68N2 | 2021 |
| Pole Base Selection Guide | HRM 68N3 | 2021 |
| Traffic Signal Base for Configurations B, C, D and E | HRM 69 | 2021 |
| Traffic Signal Base for Configurations F, G, and H | HRM 70 | 2021 |
| Traffic Signal Base for Configurations I, J, K and L | HRM 71 | 2021 |
| Traffic Signal Base for Configuration M | HRM 71A | 2021 |
| Traffic Signal Base for Configurations N, O and P | HRM 72 | 2021 |
| Traffic Signal Base for Configurations Q, R and S | HRM 72A | 2021 |
| Traffic Signal base for Configurations T, U and V | HRM 73 | 2021 |
| Traffic Signal Base for Configurations W, X and Y | HRM 73A | 2021 |
| Traffic Signal Base for Configurations Z, AA and AB | HRM 74 | 2021 |
| Traffic Signal base for Configurations AC, AD and AE | HRM 74A | 2021 |
| Foundation Revisions for Doweling into Rock | HRM 74B.1 | 2021 |
| Foundation Revisions for Doweling into Rock | HRM 74B.2 | 2021 |
| Traffic Signal base for Configuration AF | HRM 74X | 2021 |
| Base Mounted Traffic Signa Controller Cabinet | HRM 175 | 2021 |
| Base Mounted Traffic Signal Controller Cabinet with Battery Back-Up Unit | HRM 176 | 2021 |
| Street Lighting Power Enclosure Base | HRM 177 | 2021 |

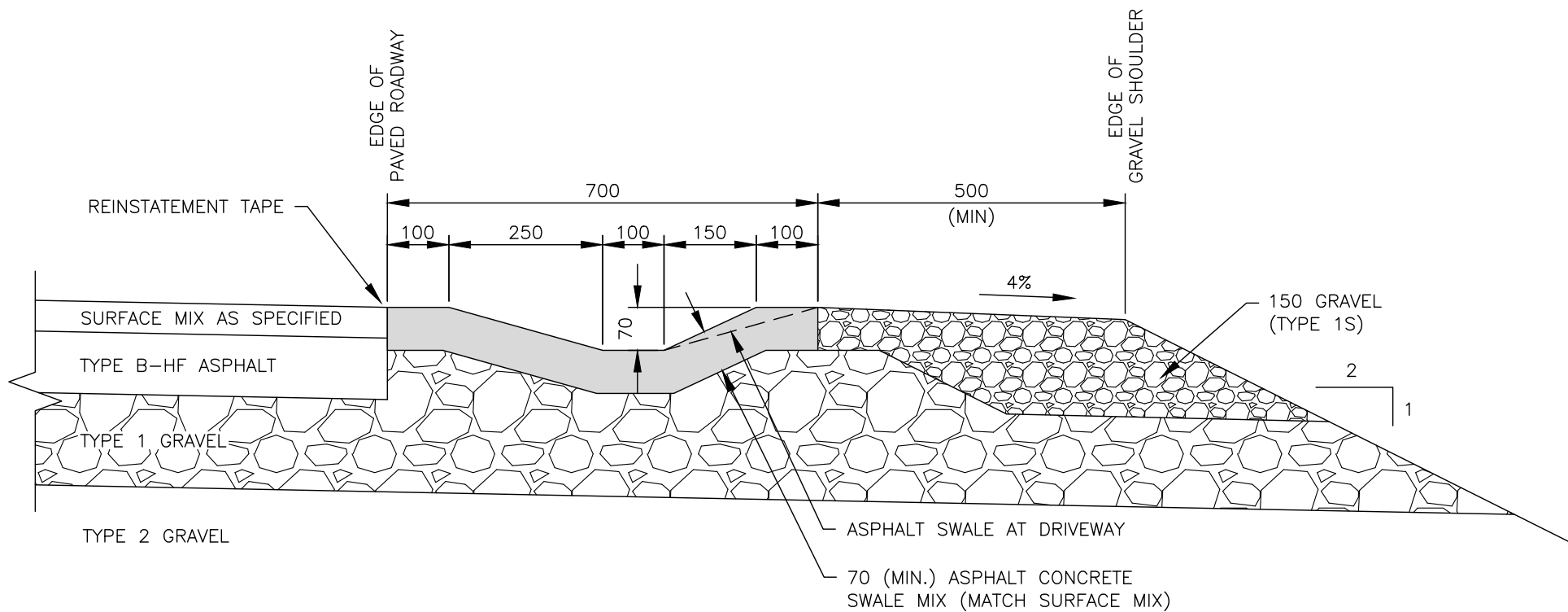

NOTE:

1. FOR ALL RURAL ROADS HAVING A GRADE EXCEEDING 7%, ASPHALT SWALES ARE REQUIRED ON EACH SIDE OF THE ROAD (ABUTTING THE ASPHALT TRAVELLED WAY) ASPHALT SWALE RUNOFF TO THE DITCH EVERY 30m OR UPSTREAM AT DRIVEWAYS.
2. ASPHALT SWALE SHALL EXTEND TO THE EDGE OF SHOULDER AND DOWN THE SLOPE BY 1 m MINIMUM.
3. MINIMUM SWALE CROSSFALL TO MATCH THE EXISTING SLOPE OF THE ROAD.
4. ASPHALT SWALE TO BE MACHINE PLACED.
5. 1 m ASPHALT APRON REQUIRED AT GRAVEL DRIVEWAYS.
6. DIMENSIONS ARE IN MILLIMETRES.

| | | |
|------------------------|-----------|---------------------------|
| <h1>HALIFAX</h1> | | |
| STANDARD DETAIL | | |
| <h2>ASPHALT SWALE</h2> | | |
| DATE: 2021 | REFERENCE | APPROVED |
| SCALE: 1:10 | | FIG No.: HRM 30 |

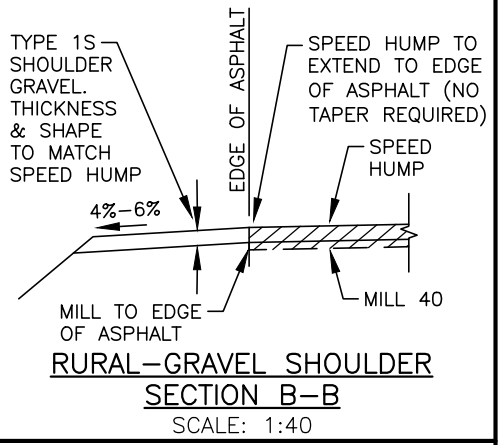
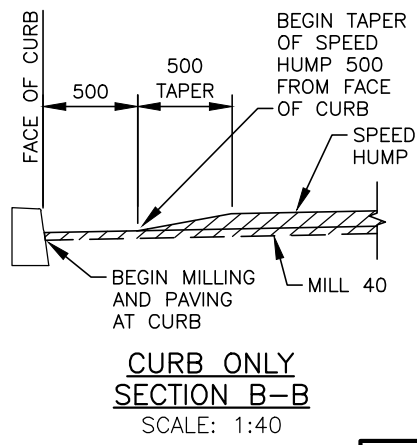
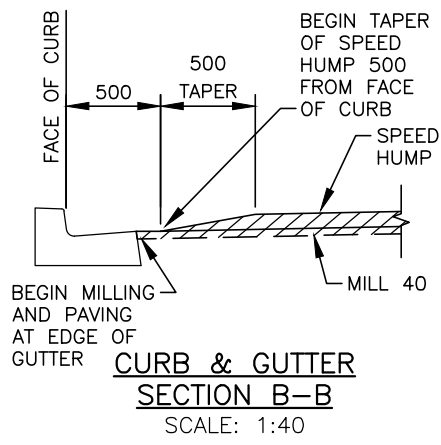
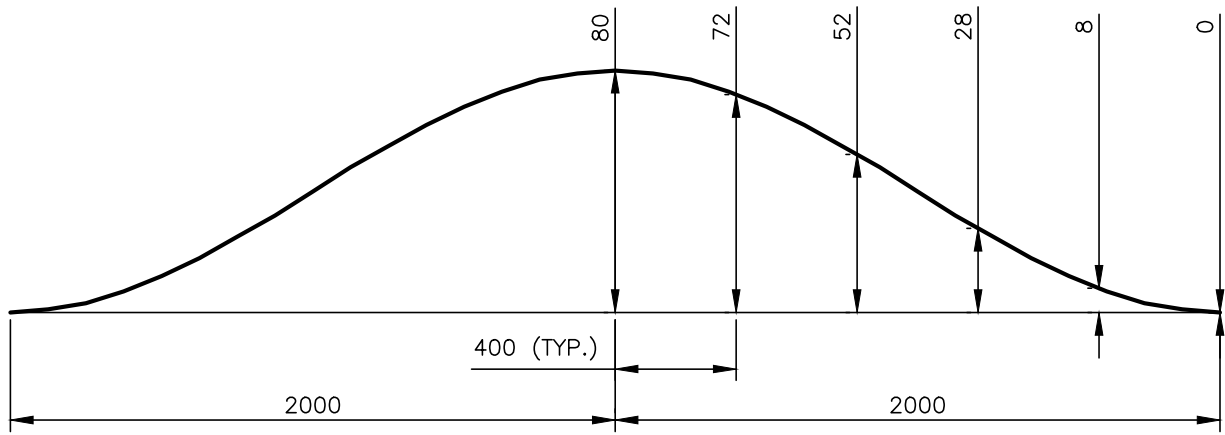
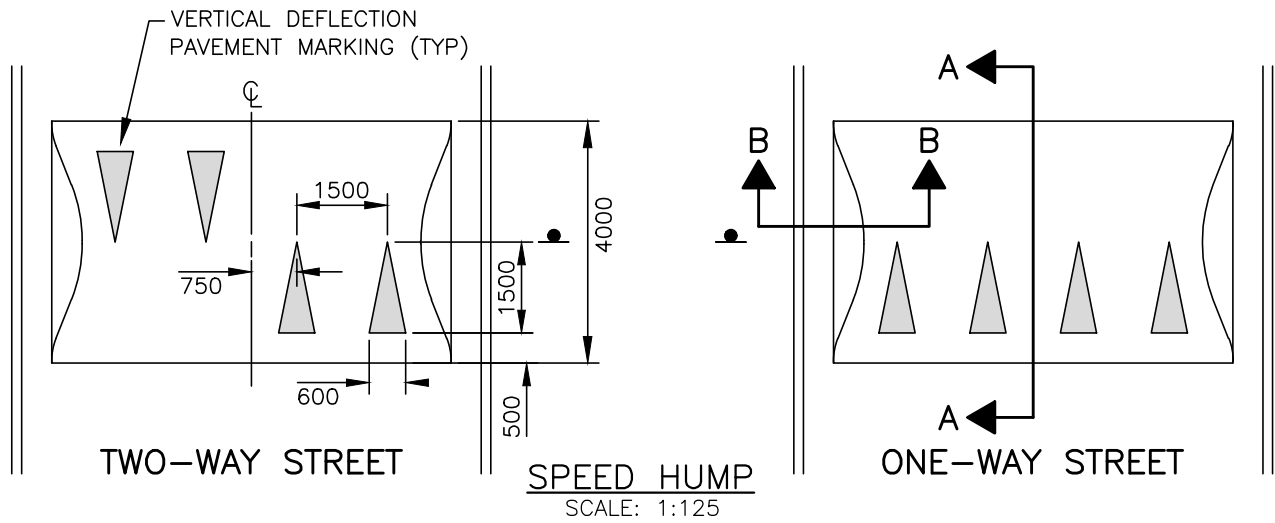

NOTES:

1. TOLERANCE FOR CONSTRUCTION IS +/- 10mm RELATIVE TO THE CURVE.
2. THE EXISTING ASPHALT SURFACE TO BE MILLED TO A DEPTH OF 40mm WHEN RETROFITTING.
3. SPEED HUMPS TO BE CONSTRUCTED USING TYPE D-HF ASPHALT (UNLESS OTHERWISE APPROVED BY HRM).
4. WHERE SPECIFIED, EXISTING UTILITY POLE OR EXISTING SIGN POSTS MAY BE USED FOR SIGNAGE.
5. DIMENSIONS ARE IN MILLIMETRES.

HALIFAX

STANDARD DETAIL

SPEED HUMP

| | | |
|--------------------|-----------|--------------------|
| DATE: 2023 | REFERENCE | APPROVED |
| SCALE: AS NOTED | | FIG No.: HRM 31 |

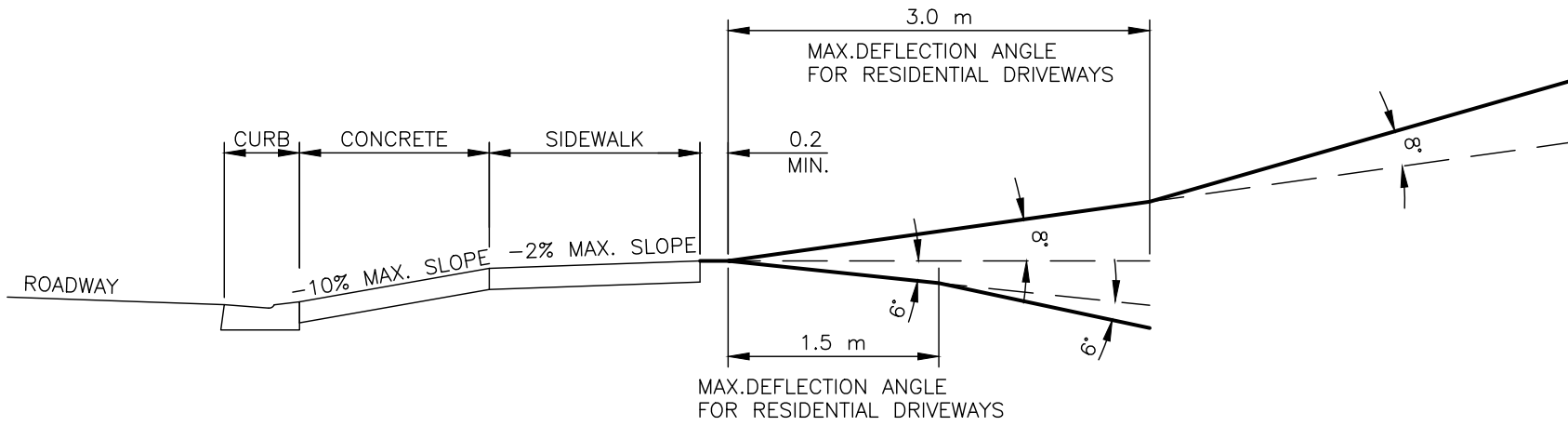

SECTION A-A

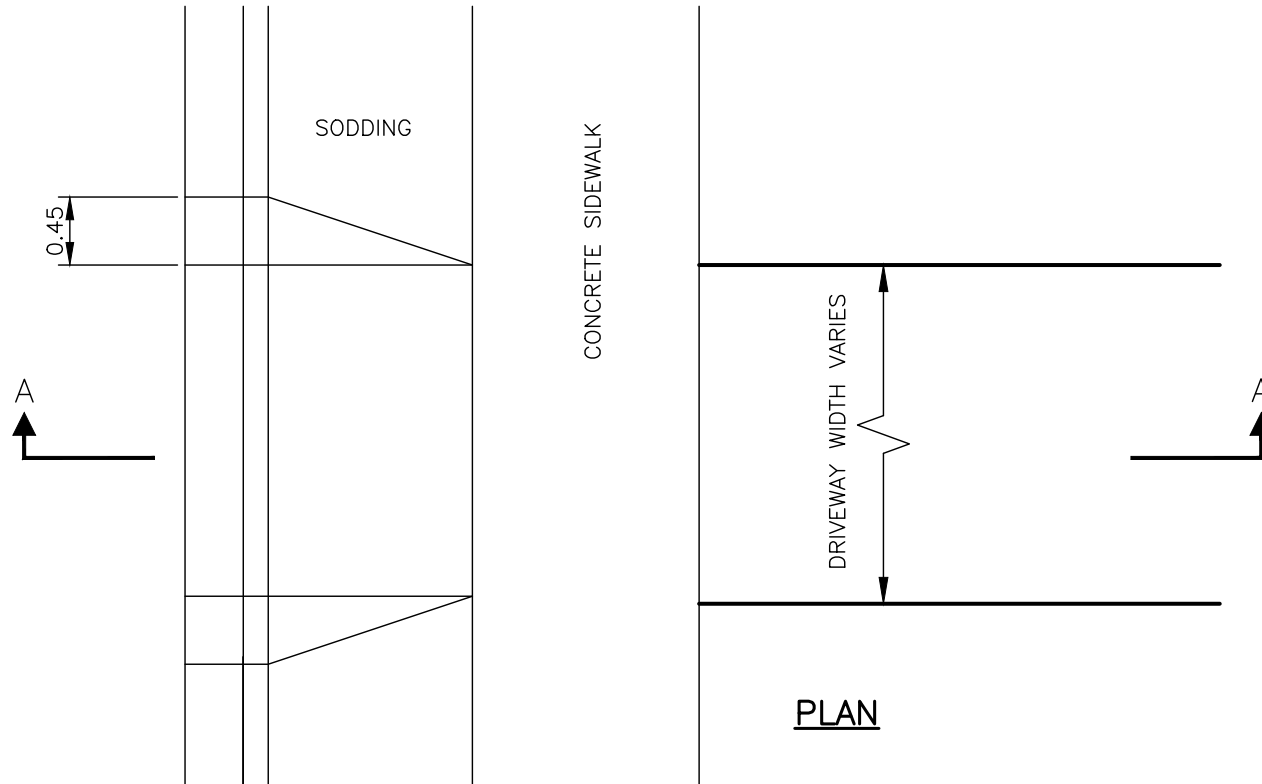

NOTE:

THIS DETAIL IS INTENDED FOR RETROFIT SITUATIONS, I.E. WHERE EXISTING DRIVEWAY GRADES MUST BE ADJUSTED TO MATCH NEW CONDITIONS IN THE STREET RIGHT-OF-WAY.

HALIFAX

STANDARD DETAIL

DRIVEWAY DEFLECTION ANGLES & GRADES

| | | | |
|--------|------|-----------|---------------|
| DATE: | 2021 | REFERENCE | APPROVED |
| SCALE: | 1:50 | | FIG No.: |
| | | | HRM 32 |

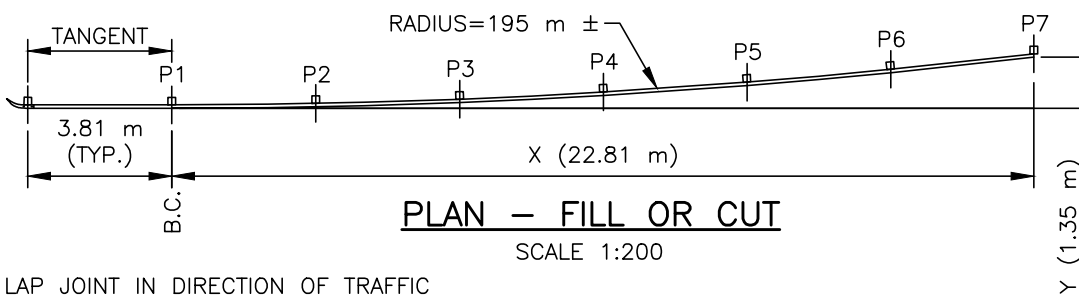

| POST OFFSET TABLE | | |
|-------------------|-------|------|
| POST # | X | Y |
| P1-P2 | 3.81 | 0.04 |
| P1-P3 | 7.62 | 0.15 |
| P1-P4 | 11.42 | 0.34 |
| P1-P5 | 15.22 | 0.60 |
| P1-P6 | 19.02 | 0.94 |
| P1-P7 | 22.81 | 1.35 |

PLAN – FILL OR CUT

SCALE 1:200

LAP JOINT IN DIRECTION OF TRAFFIC
(SEE SPLICE DETAIL)

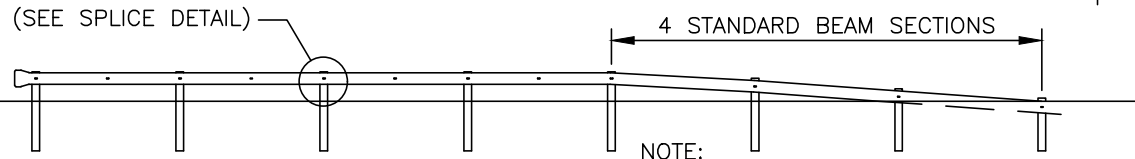

ELEVATION

SCALE 1:200

NOTE:
FOR 2 LANE/2 WAY ROADWAYS,
BURY BOTH ENDS.

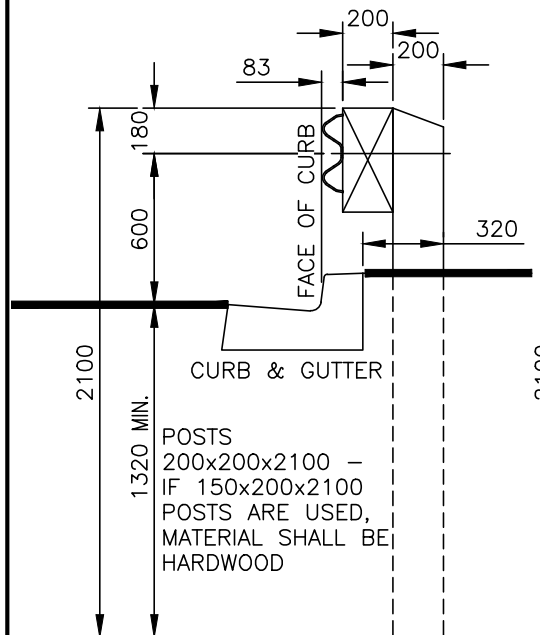

SECTION

SCALE 1:30

POSTS
200x200x2100 –
IF 150x200x2100
POSTS ARE USED,
MATERIAL SHALL BE
HARDWOOD

CURB & GUTTER

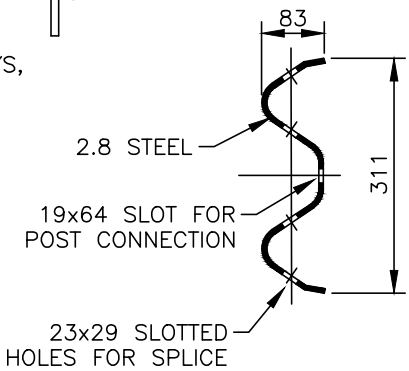

BEAM SECTION (TYP.)

SCALE 1:10

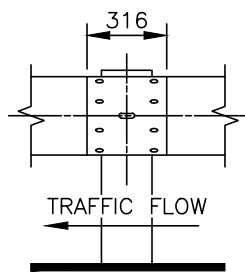

SPLICE DETAIL

SCALE 1:30

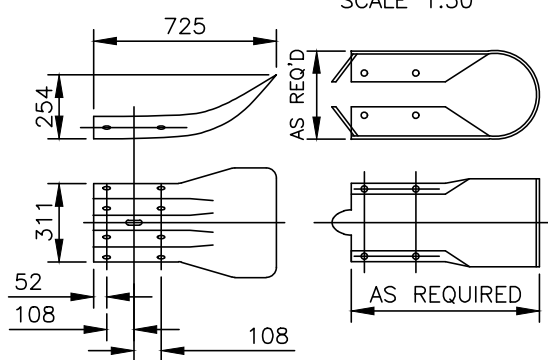

TERMINAL END

SCALE 1:30

BUFFER END

SCALE 1:30

NOTES:

1. TWO 50x75 DELINEATORS ARE REQUIRED FOR EACH POST.
2. A WHITE DELINEATOR SHALL BE PLACED ON THE SIDE OF THE POST FACING TRAFFIC.
3. A YELLOW DELINEATOR SHALL BE PLACED ON THE OPPOSITE SIDE.
4. THE DELINEATOR SHALL BE PLACED ON THE OPPOSITE SIDE.
5. THE DELINEATOR SHALL BE LOCATED AT THE EDGE OF THE POST NEAREST THE ROAD, VERTICAL, WITH THE TOP 75 BELOW THE LOWEST POINT OF THE GUIDE RAIL PANEL.
6. THE DELINEATOR SHALL BE ATTACHED WITH GALVANIZED NAILS.

HALIFAX

STANDARD DETAIL

GUIDE RAIL
INSTALLATION

| | | |
|--------------------|-----------|---------------------------|
| DATE: 2021 | REFERENCE | APPROVED |
| SCALE: AS NOTED | | FIG No.: HRM 36 |

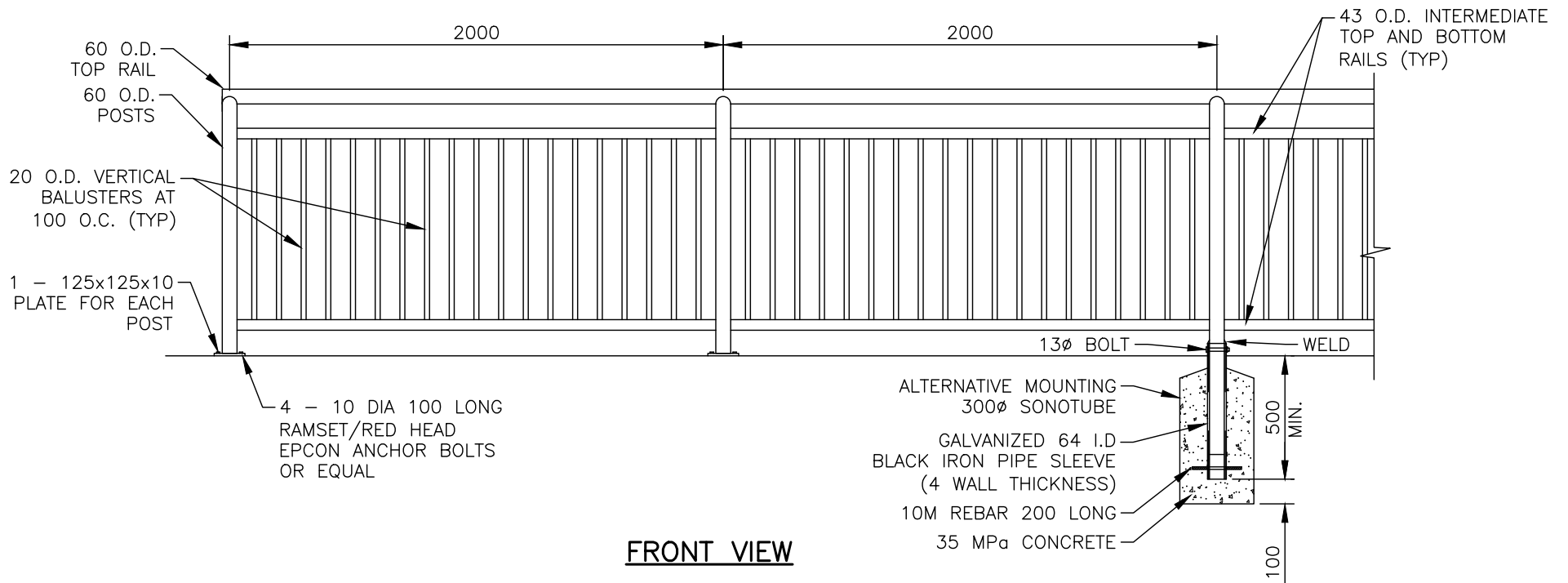

FRONT VIEW

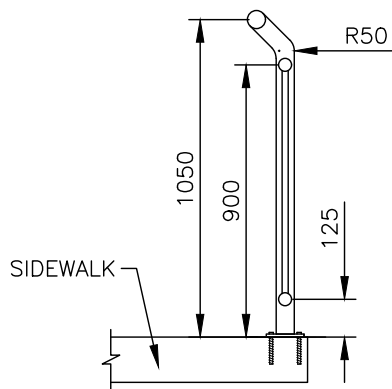

SIDE VIEW

NOTE:

RAILING SYSTEM TO BE HOT DIPPED GALVANIZED AFTER FABRICATION. FIELD WELDS, IF NECESSARY SHALL BE PROTECTED WITH COLD GALVANIZING.

HALIFAX

STANDARD DETAIL

RAILING

| | | | |
|--------|------|-----------|---------------------------|
| DATE: | 2021 | REFERENCE | APPROVED |
| SCALE: | 1:25 | | FIG No.: HRM 37 |

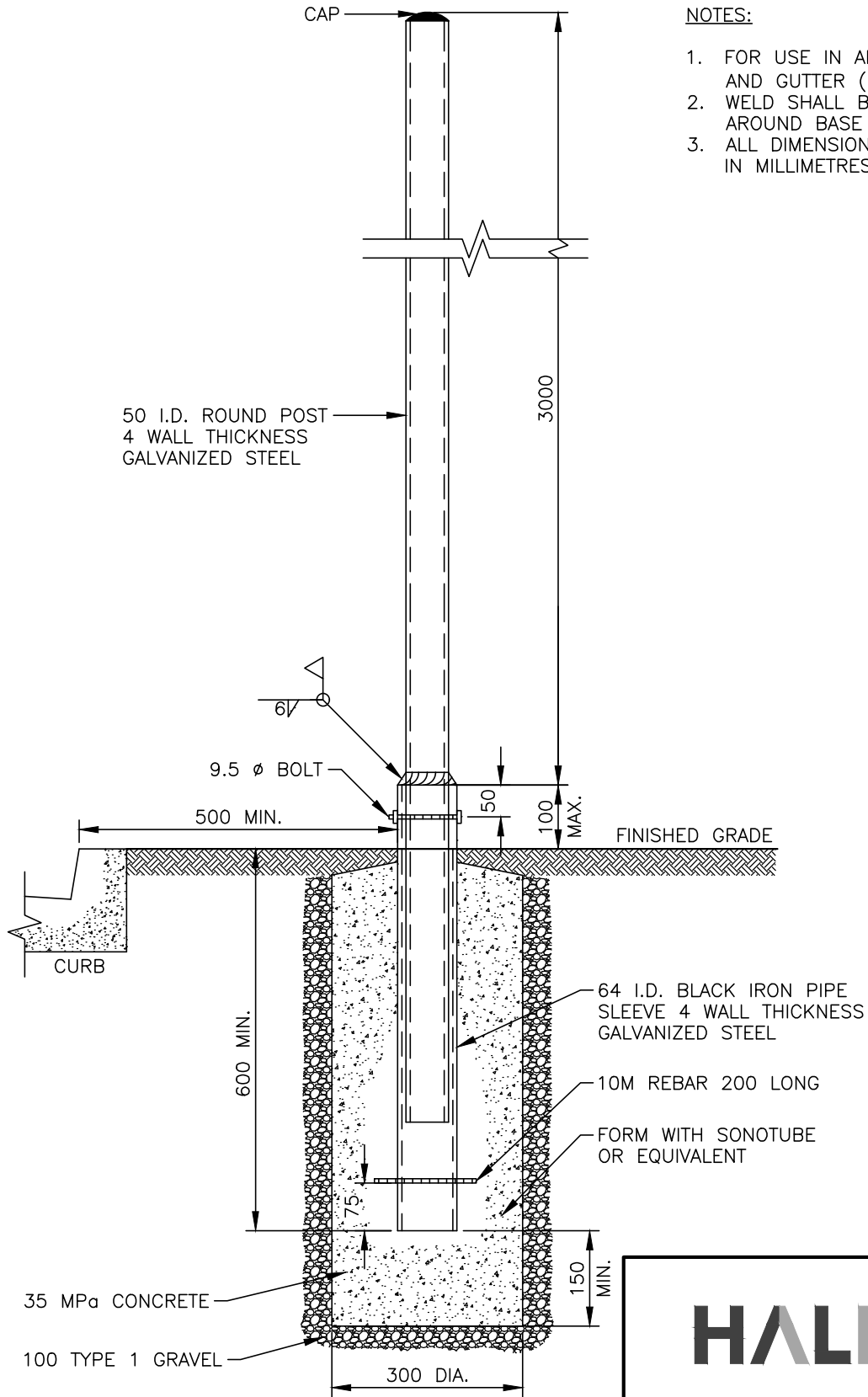

NOTES:

1. FOR USE IN AREAS WITH CURB AND GUTTER (URBAN LOCATIONS)
2. WELD SHALL BE COMPLETED AROUND BASE AND POST.
3. ALL DIMENSIONS ARE IN MILLIMETRES.

| | | |
|-------------------------|-----------|----------|
| HALIFAX | | |
| STANDARD DETAIL | | |
| URBAN TRAFFIC SIGN POST | | |
| DATE: | REFERENCE | APPROVED |
| 2023 | | |
| SCALE: | | FIG No.: |
| 1:10 | | HRM 38 |

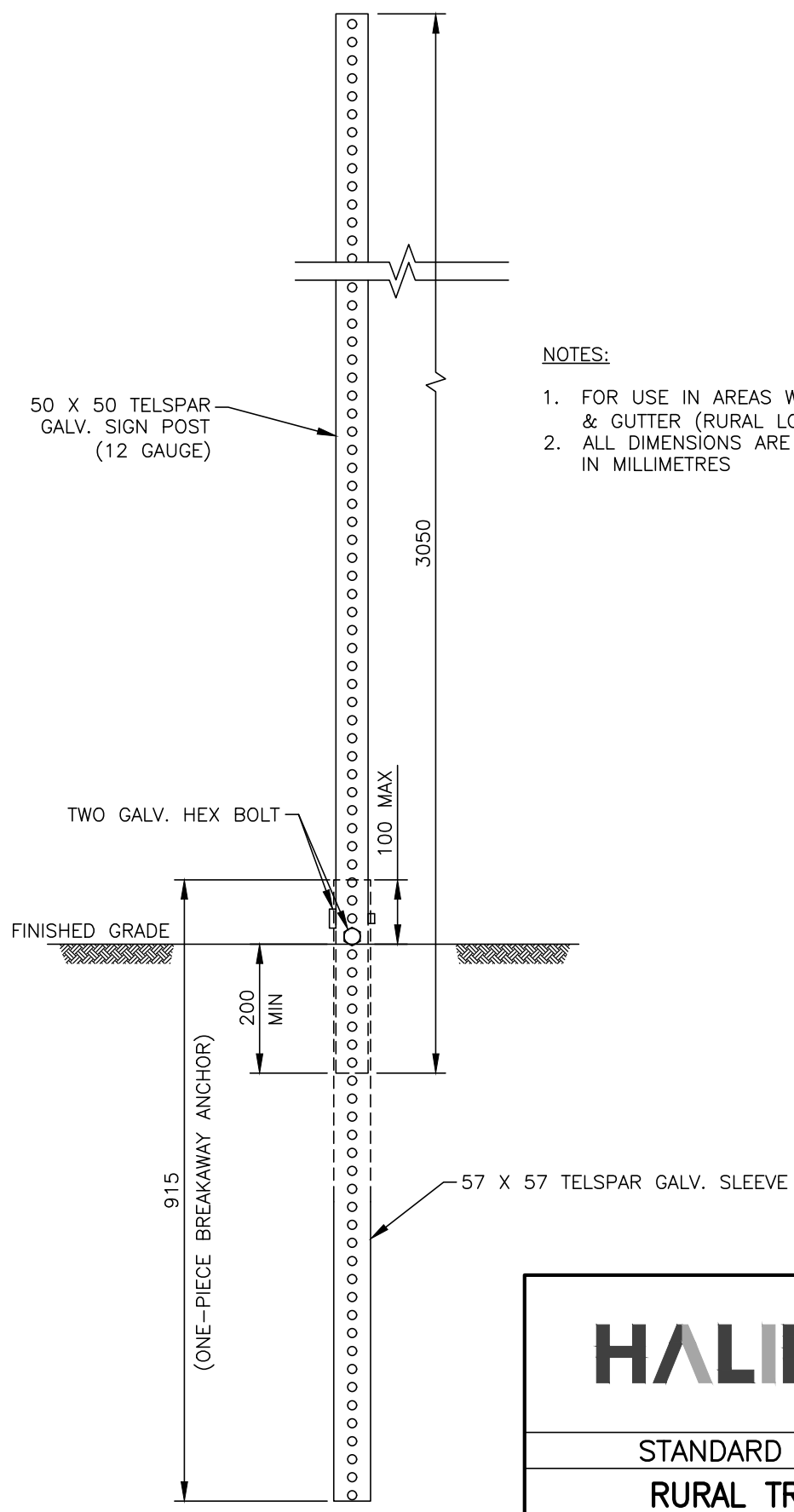

50 X 50 TELSPAR
GALV. SIGN POST
(12 GAUGE)

NOTES:

1. FOR USE IN AREAS WITHOUT CURB & GUTTER (RURAL LOCATIONS)..
2. ALL DIMENSIONS ARE IN MILLIMETRES

TWO GALV. HEX BOLT

FINISHED GRADE

200
MIN

100
MAX

3050

915
(ONE-PIECE BREAKAWAY ANCHOR)

57 X 57 TELSPAR GALV. SLEEVE

| | | |
|------------------------------------|-----------|---------------------------|
| <h1>HALIFAX</h1> | | |
| STANDARD DETAIL | | |
| RURAL TRAFFIC SIGN POST | | |
| DATE: 2023 | REFERENCE | APPROVED |
| SCALE: 1:10 | | FIG No.: HRM 39 |

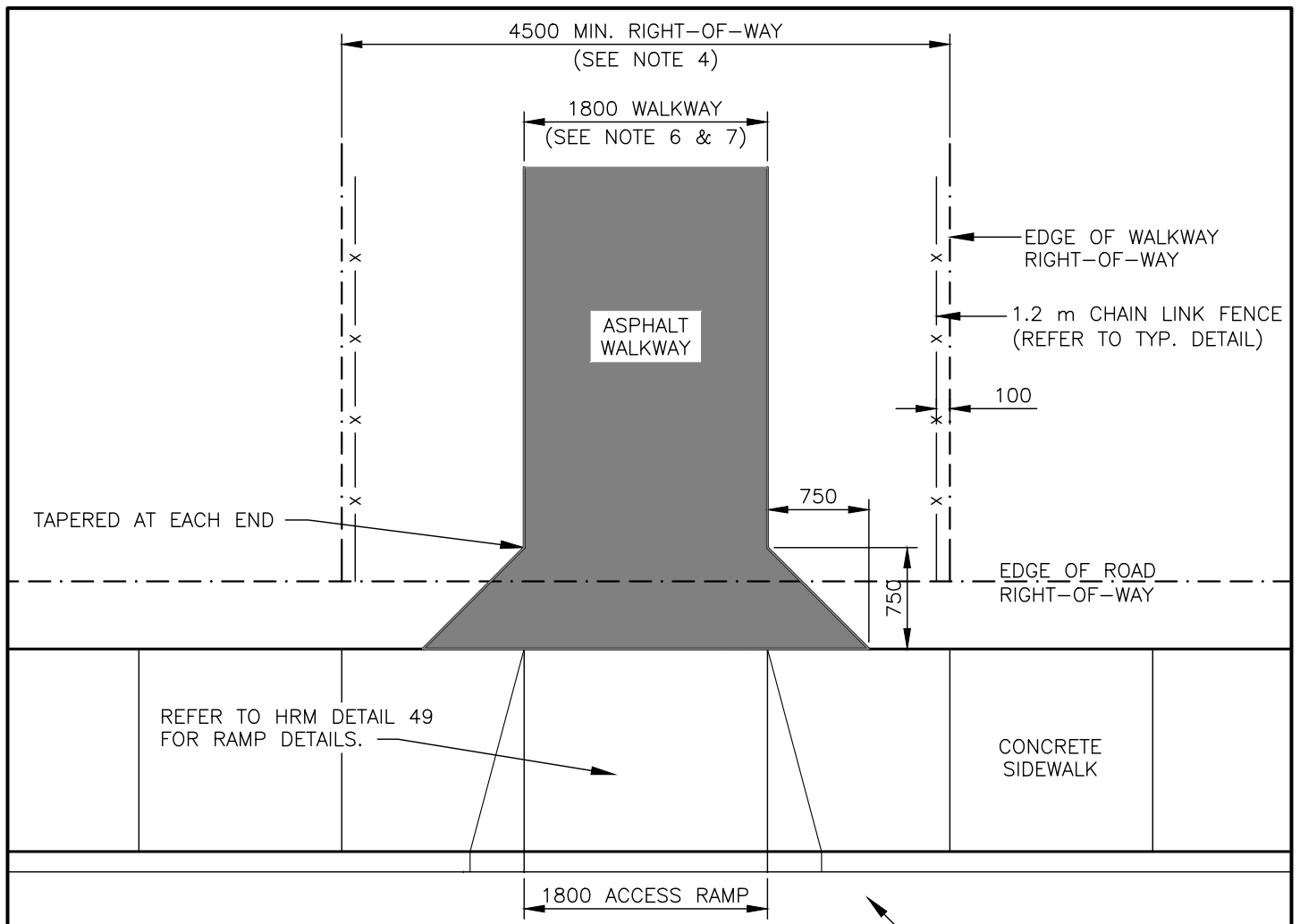

PLAN

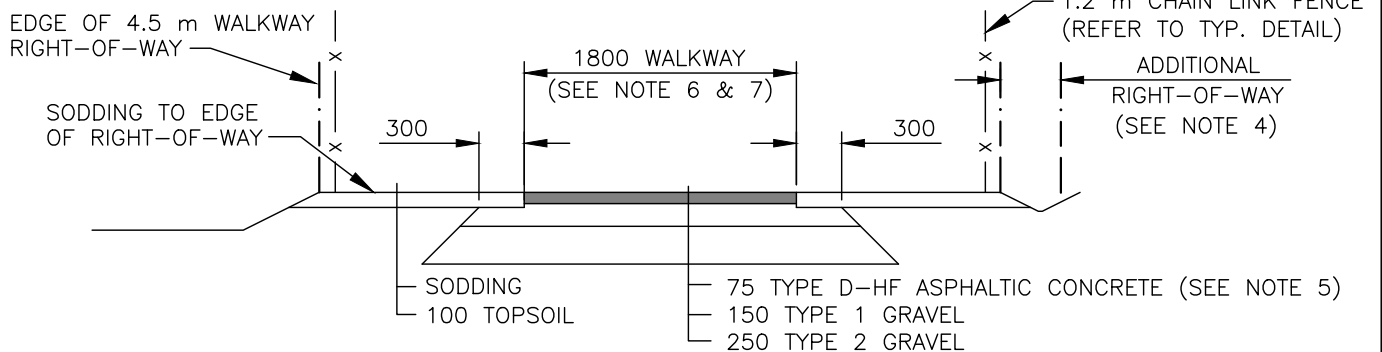

PROFILE

NOTES:

1. WALKWAY CROSSFALL TO BE 2% WITH NO CROWN.
2. THE ENGINEER MAY REQUIRE OR PERMIT USE OF LOW MAINTENANCE MATERIALS IN PLACE OF SODDING.
3. WHERE MUNICIPAL SERVICE SYSTEMS ARE REQUIRED THE MIN. R.O.W. IS TO BE INCREASED TO 6.0 m. THE CHAIN LINK FENCE SHALL BE LOCATED 100 FROM THE EDGE OF THE INCREASED 6.0 m R.O.W..
4. TO ACCOMMODATE SWALE OR CUT/FILL SLOPES ADDITIONAL RIGHT-OF-WAY MAY BE REQUIRED.
5. SURFACE MATERIAL TO BE ASPHALTIC CONCRETE UNLESS DIRECTED BY THE ENGINEER.
6. GRADE AS DIRECTED BY THE ENGINEER.
7. TO BE PLACED WITH SPREADER.

HALIFAX

STANDARD DETAIL

TYPICAL WALKWAY

| | | | |
|--------|------|-----------|---------------------------|
| DATE: | 2021 | REFERENCE | APPROVED |
| SCALE: | 1:50 | | FIG No.: HRM 40 |

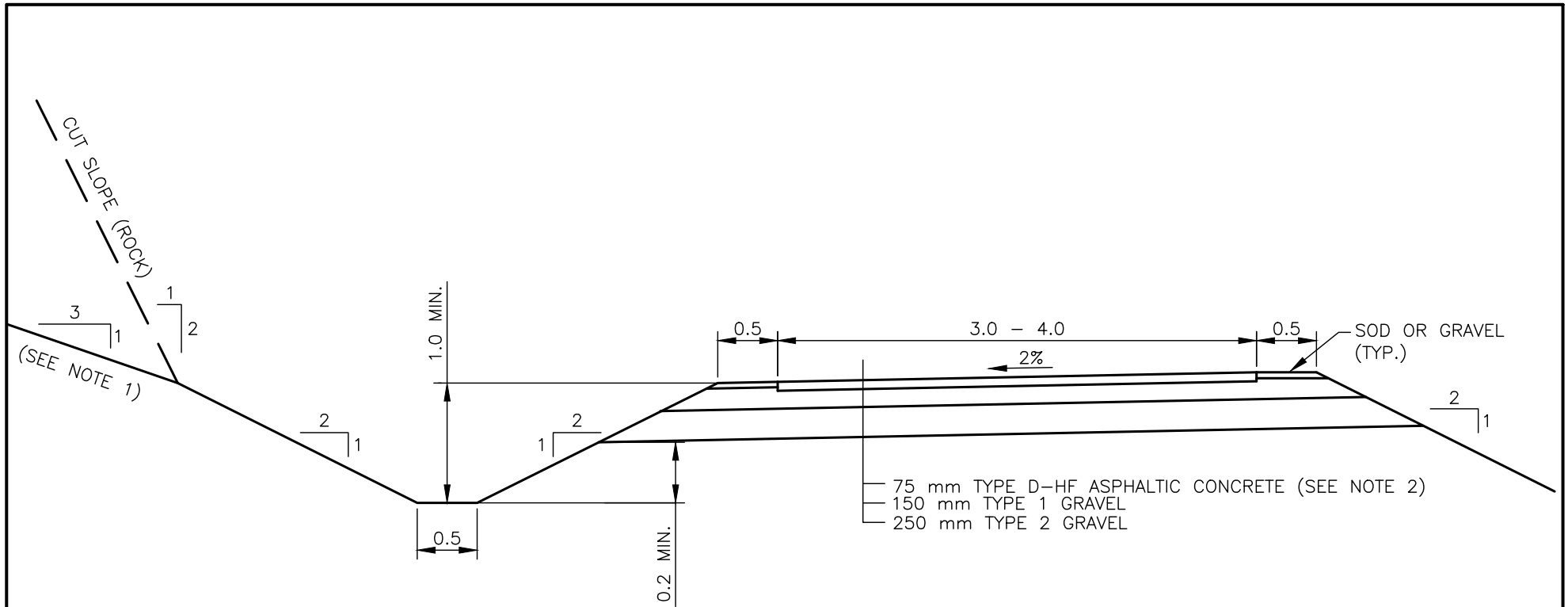

NOTES:

1. ADDITIONAL SLOPE STABILIZATION AS PER GEOTECHNICAL REPORT.
2. SURFACE MATERIAL TO BE ASPHALTIC CONCRETE UNLESS DIRECTED BY THE ENGINEER.
3. RAILING REQUIRED IN FILL GREATER THAN 1.5 m, OR ADJACENT TO WATER.
4. FALSE DITCH REQUIREMENTS SHALL MEET HALIFAX WATER SPECIFICATIONS.
5. MINIMUM 3.0 m CLEAR WIDTH.

HALIFAX

STANDARD DETAIL

ACTIVE TRANSPORTATION
OFF ROAD TRAIL

| | | | |
|--------|------|-----------|---------------------------|
| DATE: | 2021 | REFERENCE | APPROVED |
| SCALE: | 1:50 | | FIG No.: HRM 41 |

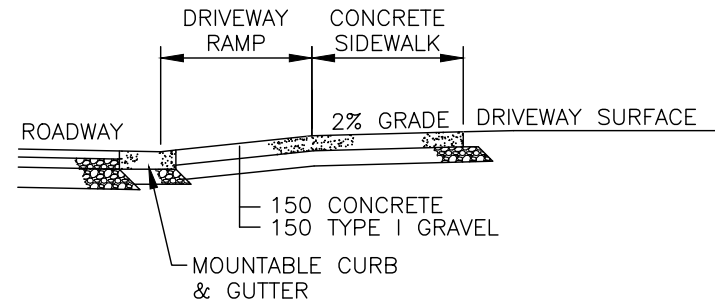
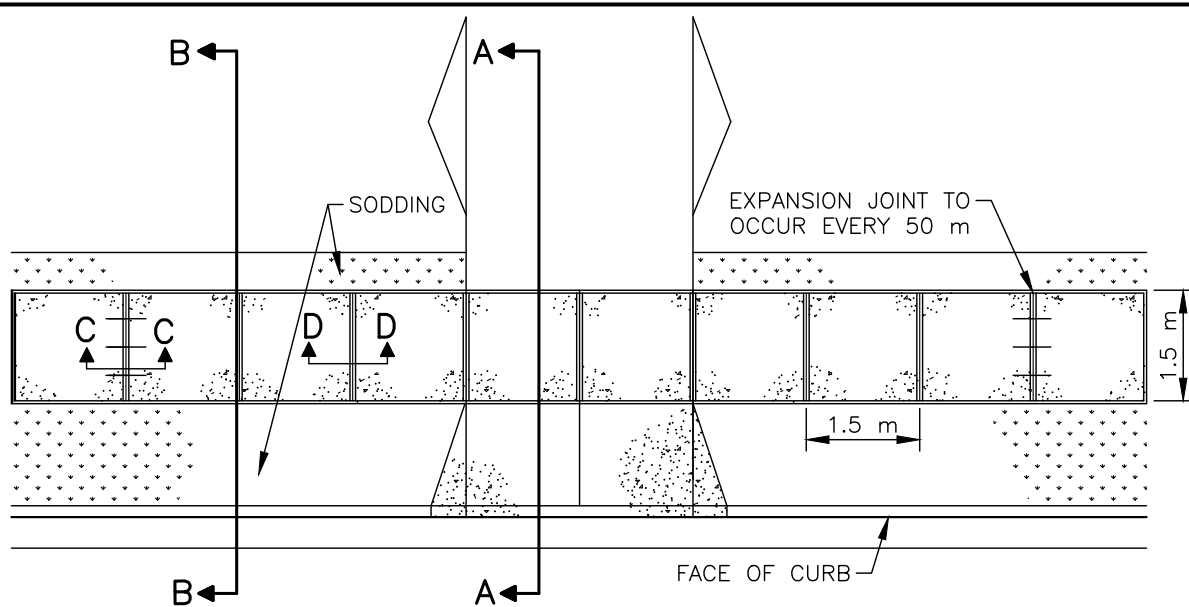

SECTION A-A
(DRIVEWAY CROSS-SECTION)

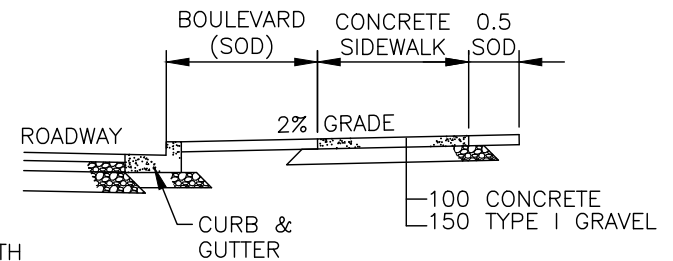

SECTION B-B
(SIDEWALK CROSS-SECTION)

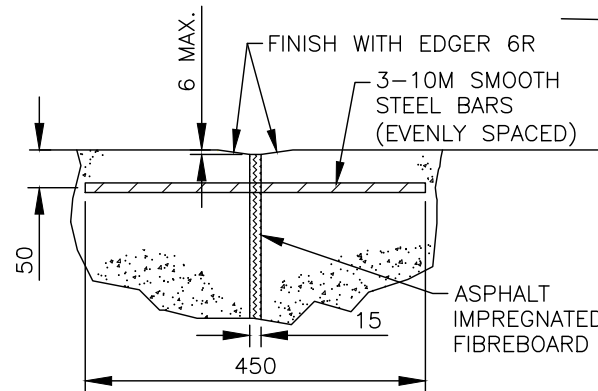

SECTION C-C
(EXPANSION JOINT)

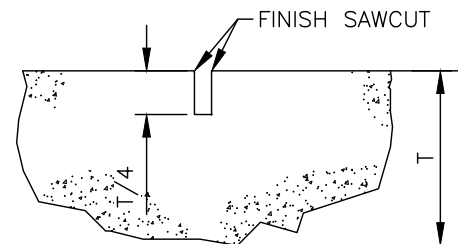

SECTION D-D
(CONTROL JOINT)

NOTES:

1. CONCRETE SIDEWALK AT COMMERCIAL DRIVEWAY TO BE 150 THICK WITH 150x150 WELDED WIRE MESH.
2. CRUSHED ROCK BASE TO EXTEND 150 BEYOND EDGE OF SIDEWALK STRUCTURE.
3. CONTROL JOINTS ARE TO BE SAW CUT.
4. SIDEWALK ABUTTING HIGH DENSITY AREAS SHALL HAVE FULL WIDTH (3 m) SIDEWALKS.
5. SIDEWALKS ABUTTING COMMERCIAL AREAS ARE TO BE FULL WIDTH (3 m) AND 150 mm THICKNESS.
6. EXPANSION JOINT BARS ARE TO BE GREASED ON ONE SIDE OF THE JOINT.
7. DURING CONSECUTIVE POURS, THE END OF EACH POUR IS TO OCCUR AT AN EXPANSION JOINT. WHERE THIS IS NOT FEASIBLE, AN ADDITIONAL EXPANSION JOINT IS TO BE INSTALLED.
8. INSTALL A 9 m LONG CONCRETE LANDING PAD AT ALL BUS STOP LOCATIONS. INCREASE THIS TO 14.5 m FOR ARTICULATED BUS ROUTES.
9. WHEN BOULEVARD IS LESS THAN 1.5 m OR WHEN THE SIDEWALK ABUTS THE CURB & GUTTER, REFER TO HRM 133.
10. SEE HRM 48 FOR SIDEWALK WITHIN 6 m OF TREES.
11. DIMENSIONS ARE IN MILLIMETRES UNLESS OTHERWISE NOTED.

HALIFAX

STANDARD DETAIL

URBAN SIDEWALK

| | | |
|------------|-----------|-----------------|
| DATE: 2021 | REFERENCE | APPROVED |
| SCALE: NTS | | FIG No.: HRM 44 |

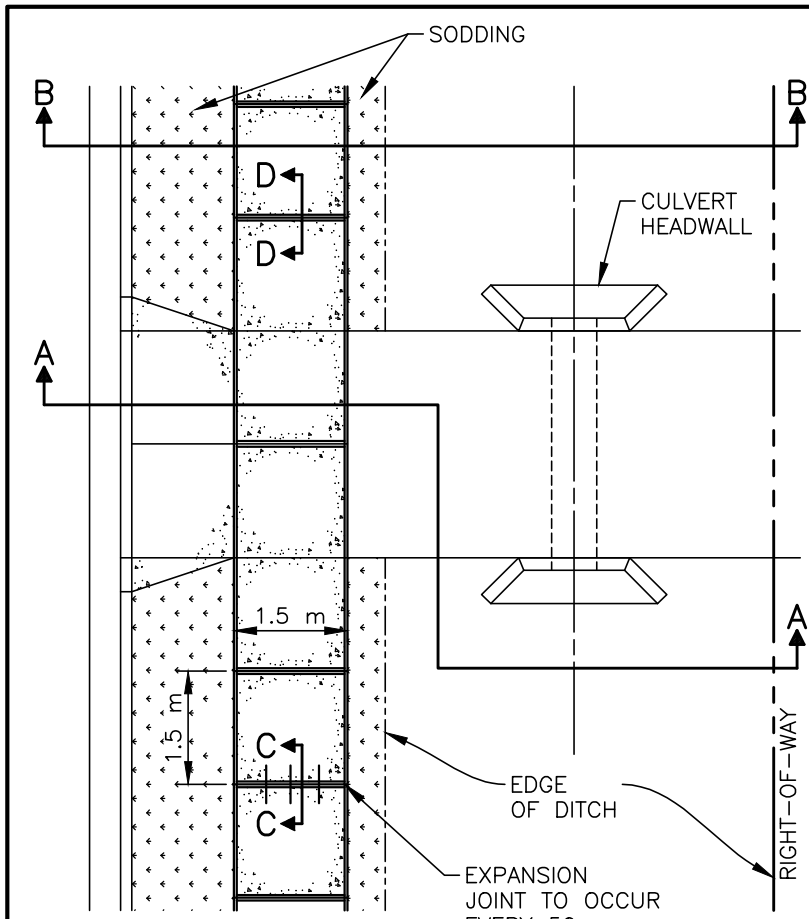

PLAN

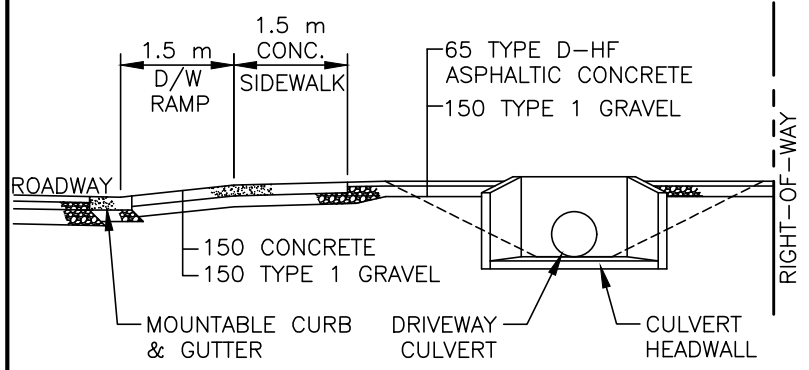

SECTION A-A
(DRIVEWAY CROSS-SECTION)

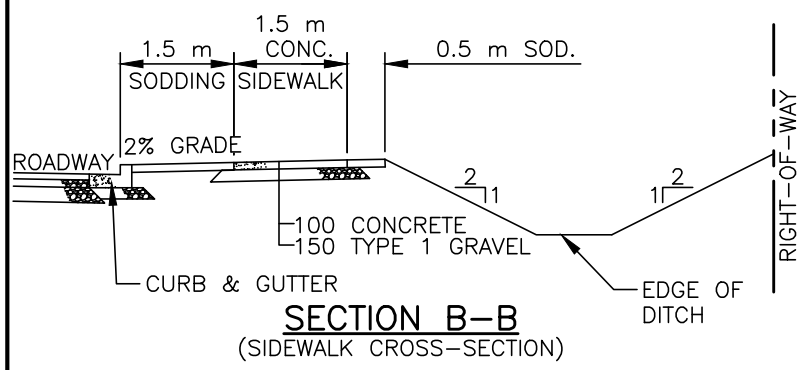

SECTION B-B
(SIDEWALK CROSS-SECTION)

NOTES:

1. CONCRETE SIDEWALK AT COMMERCIAL DRIVEWAY TO BE 150 THICK WITH 150 x 150 WELDED WIRE MESH.
2. CRUSHED ROCK BASE TO EXTEND 150 BEYOND EDGE OF SIDEWALK STRUCTURE.
3. CONTROL JOINTS ARE TO BE SAW CUT.
4. SIDEWALKS ABUTTING COMMERCIAL AREAS ARE TO BE FULL WIDTH (3 m) AND 150 mm THICKNESS.
5. EXPANSION JOINT BARS ARE TO BE GREASED ON ONE SIDE OF THE JOINT.
6. DURING CONSECUTIVE POURS, THE END OF EACH POUR IS TO OCCUR AT AN EXPANSION JOINT. WHERE THIS IS NOT FEASIBLE, AN ADDITIONAL EXPANSION JOINT IS TO BE INSTALLED.
7. INSTALL A 9 m LONG CONCRETE LANDING PAD AT ALL BUS STOP LOCATIONS. INCREASE THIS TO 14.5 m FOR ARTICULATED BUS ROUTES.
8. WHEN BOULEVARD IS LESS THAN 1.5 m OR WHEN THE SIDEWALK ABUTS THE CURB & GUTTER, REFER TO HRM 133.
9. DIMENSIONS ARE IN MILLIMETRES UNLESS OTHERWISE NOTED.

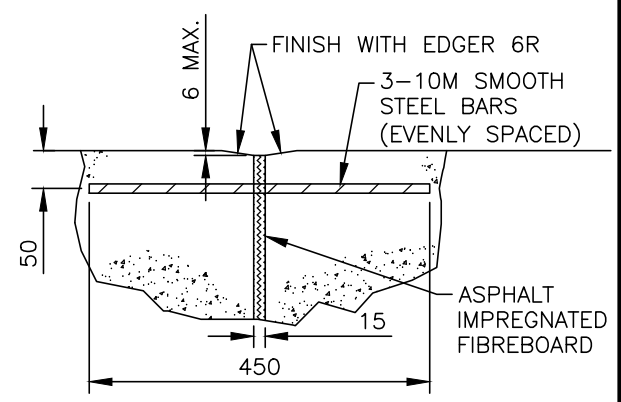

SECTION C-C
(EXPANSION JOINT)

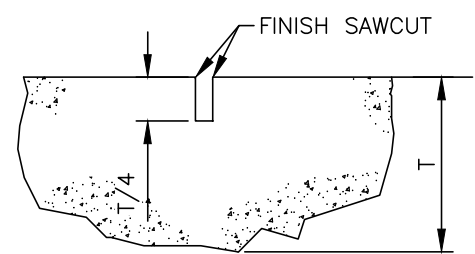

SECTION D-D
(CONTROL JOINT)

HALIFAX

STANDARD DETAIL

RURAL TYPE I SIDEWALK

| | | |
|--------|-----------|----------|
| DATE: | REFERENCE | APPROVED |
| 2021 | | |
| SCALE: | | FIG No.: |
| NTS | | HRM 45 |

NOTES:

1. CONCRETE SIDEWALK AT COMMERCIAL DRIVEWAY TO BE 150 THICK WITH 150x150 WELDED WIRE MESH.
2. CRUSHED ROCK BASE TO EXTEND 150 BEYOND EDGE OF SIDEWALK STRUCTURE.
3. CONTROL JOINTS ARE TO BE SAW CUT.
4. SIDEWALKS ABUTTING COMMERCIAL AREAS ARE TO BE FULL WIDTH (3 m) AND 150 mm THICKNESS.
5. EXPANSION JOINT BARS ARE TO BE GREASED ON ONE SIDE OF THE JOINT.
6. DURING CONSECUTIVE POURS, THE END OF EACH POUR IS TO OCCUR AT AN EXPANSION JOINT. WHERE THIS IS NOT FEASIBLE, AN ADDITIONAL EXPANSION JOINT IS TO BE INSTALLED.
7. INSTALL A 9 m LONG CONCRETE LANDING PAD AT ALL BUS STOP LOCATIONS. INCREASE THIS TO 14.5 m FOR ARTICULATED BUS ROUTES.
8. WHEN BOULEVARD IS LESS THAN 1.5 m OR WHEN THE SIDEWALK ABUTS THE CURB & GUTTER, REFER TO HRM 133.

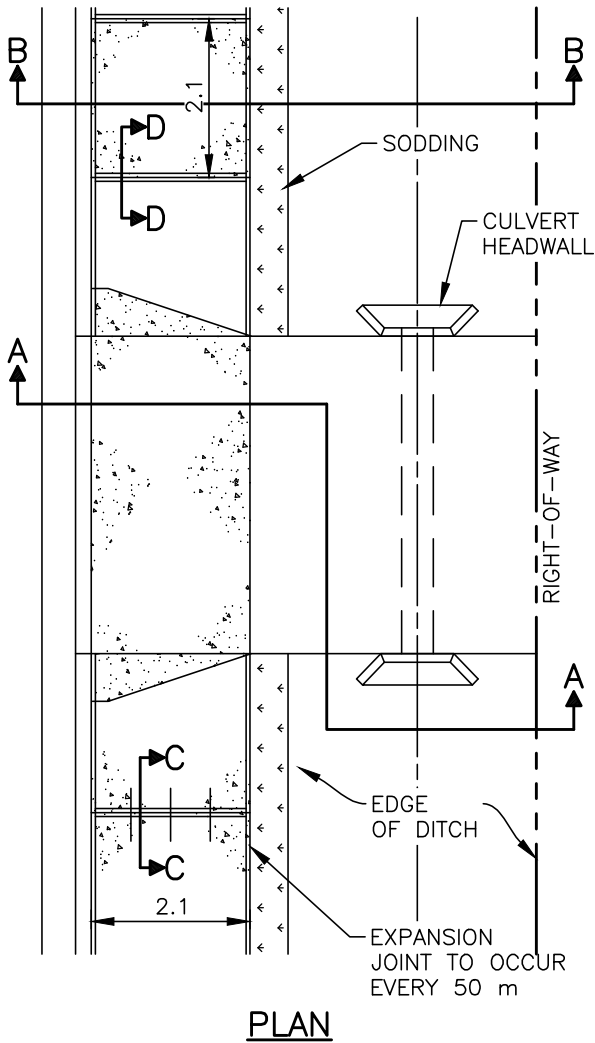

PLAN

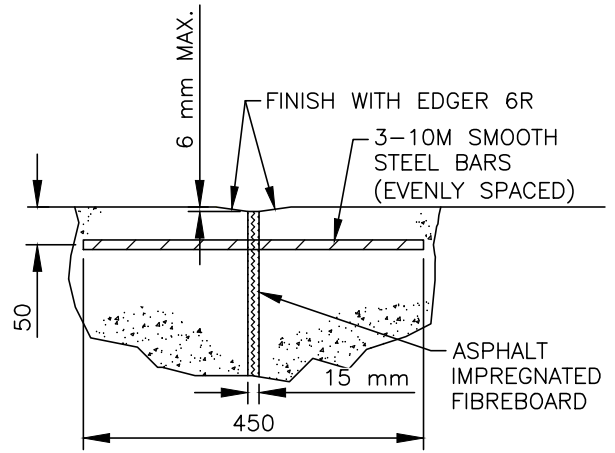

**SECTION C-C
(EXPANSION JOINT)**

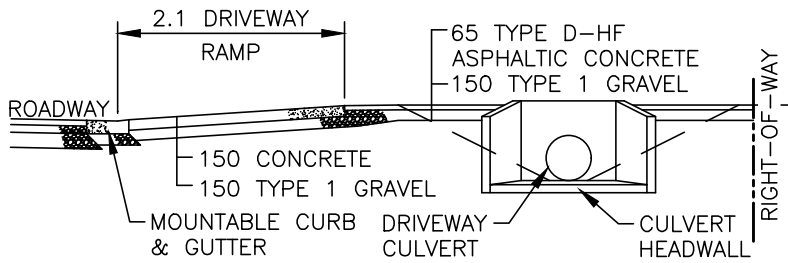

**SECTION A-A
(DRIVEWAY CROSS-SECTION)**

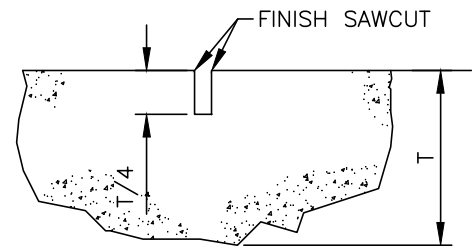

**SECTION D-D
(CONTROL JOINT)**

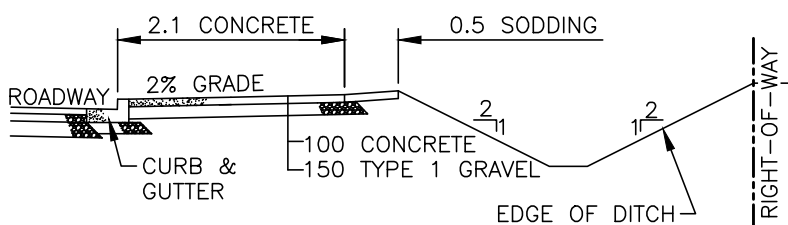

**SECTION B-B
(DRIVEWAY CROSS-SECTION)**

HALIFAX

STANDARD DETAIL

**RURAL TYPE II
SIDEWALK**

| | | | |
|--------|------|-----------|---------------|
| DATE: | 2021 | REFERENCE | APPROVED |
| SCALE: | NTS | | FIG No.: |
| | | | HRM 46 |

NOTES:

1. CONCRETE SIDEWALK AT COMMERCIAL DRIVEWAY TO BE 150 THICK WITH 150 x 150 WELDED WIRE MESH.
2. CRUSHED ROCK BASE TO EXTEND 150 BEYOND EDGE OF SIDEWALK STRUCTURE.
3. CONTROL JOINTS ARE TO BE SAW CUT.
4. SIDEWALKS ABUTTING COMMERCIAL AREAS ARE TO BE FULL WIDTH (3 m) AND 150 mm THICKNESS.
5. EXPANSION JOINT BARS ARE TO BE GREASED ON ONE SIDE OF THE JOINT. DURING CONSECUTIVE POURS, THE END OF EACH POUR IS TO OCCUR AT AN EXPANSION JOINT. WHERE THIS IS NOT FEASIBLE, AND ADDITIONAL EXPANSION JOINT IS TO BE INSTALLED.
6. INSTALL A 9 m LONG CONCRETE LANDING PAD AT ALL BUS STOP LOCATIONS. INCREASE THIS TO 14.5 m FOR ARTICULATED BUS ROUTES.

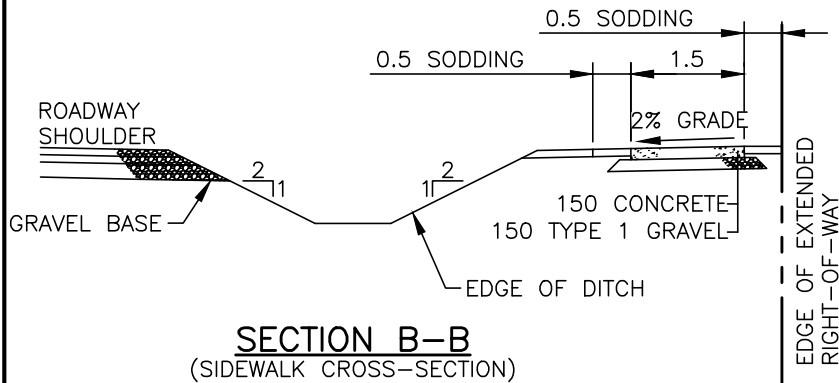
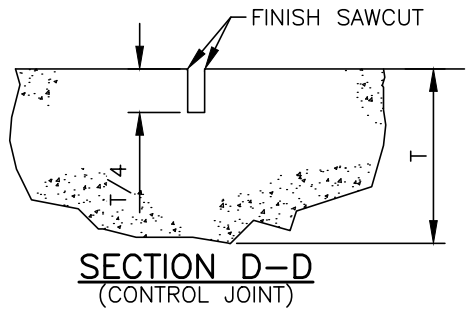
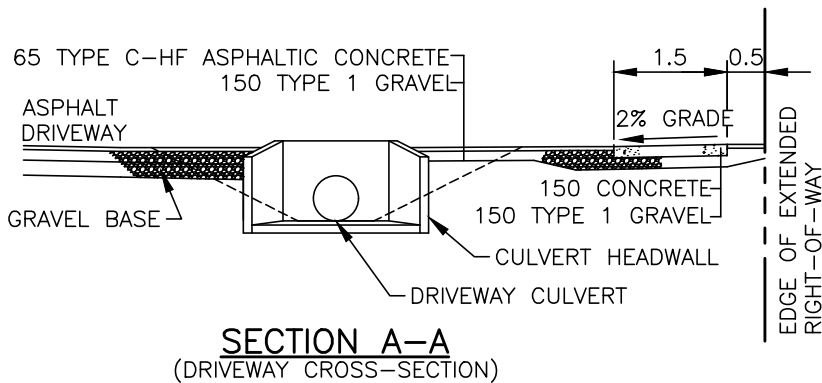
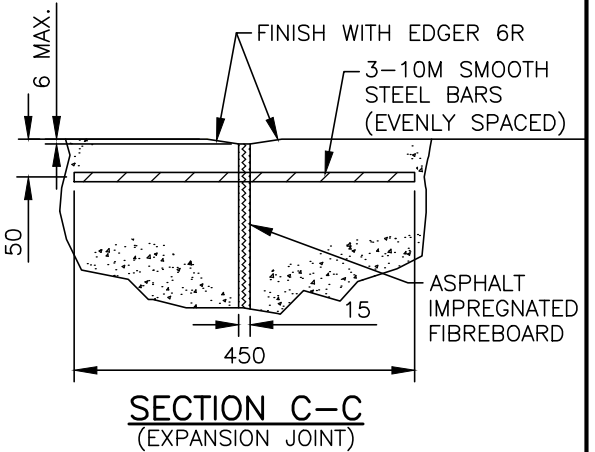
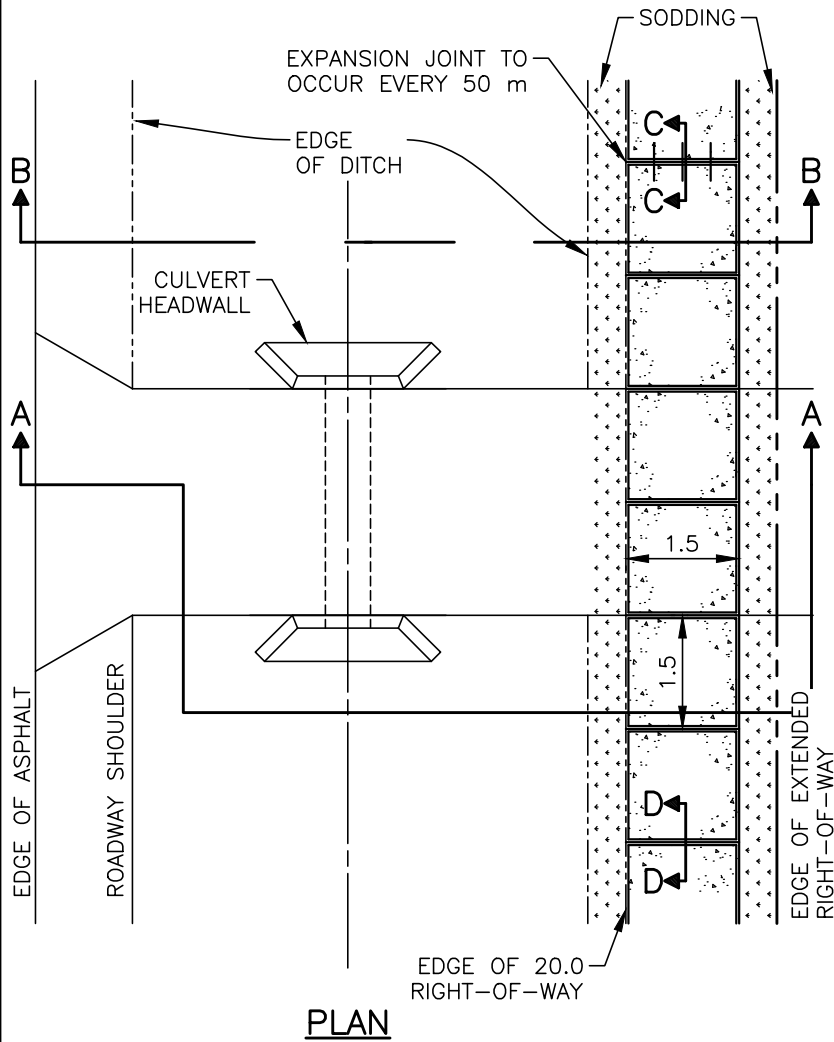

HALIFAX

STANDARD DETAIL

RURAL TYPE III SIDEWALK

| | | |
|--------|-----------|----------|
| DATE: | REFERENCE | APPROVED |
| 2021 | | |
| SCALE: | | FIG No.: |
| NTS | | HRM 47 |

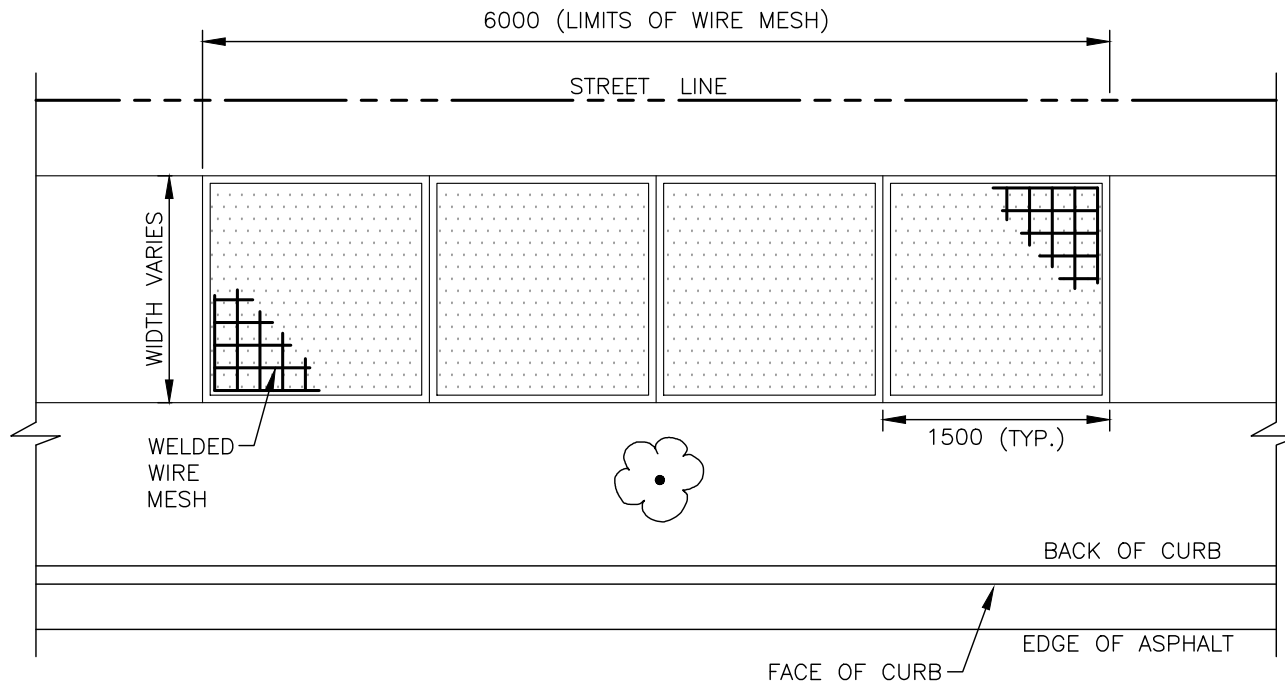

PLAN

NOTES:

1. WELDED WIRE MESH TO BE 150 X 150 – M.W. 18.7 X M.W. 18.7 (WELDED WIRE FABRIC 4.88 MM DIA.)
2. PLACED 3000 EACH SIDE FROM CENTRE OF TREE AT 1/2 THE SLAB DEPTH, FULL SIDEWALK WIDTH, CHAIRS REQUIRED TO ACHIEVE 1/2 DEPTH PLACEMENT OF WWF.
3. NO TREE ROOTS TO BE REMOVED WITHOUT HRM APPROVAL.
4. ALL DIMENSIONS IN MILLIMETRES.

HALIFAX

STANDARD DETAIL

**CONCRETE SIDEWALK
REINFORCING**

| | | | |
|--------|------|-----------|---------------------------|
| DATE: | 2023 | REFERENCE | APPROVED |
| SCALE: | 1:50 | | FIG No.: HRM 48 |

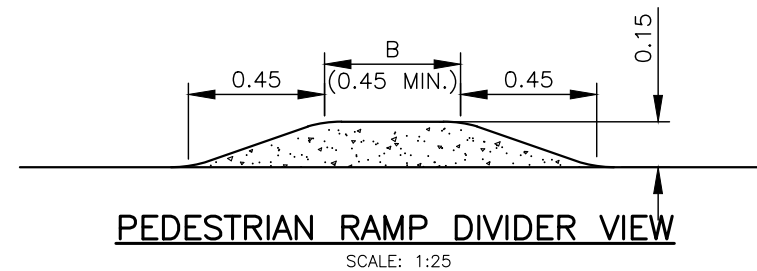
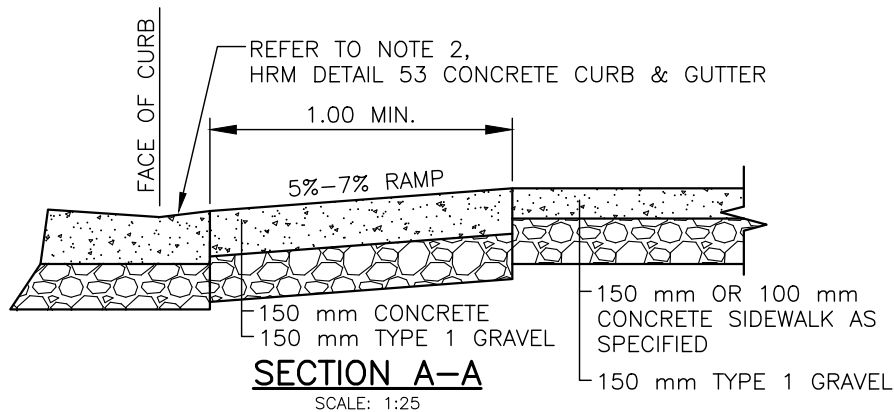
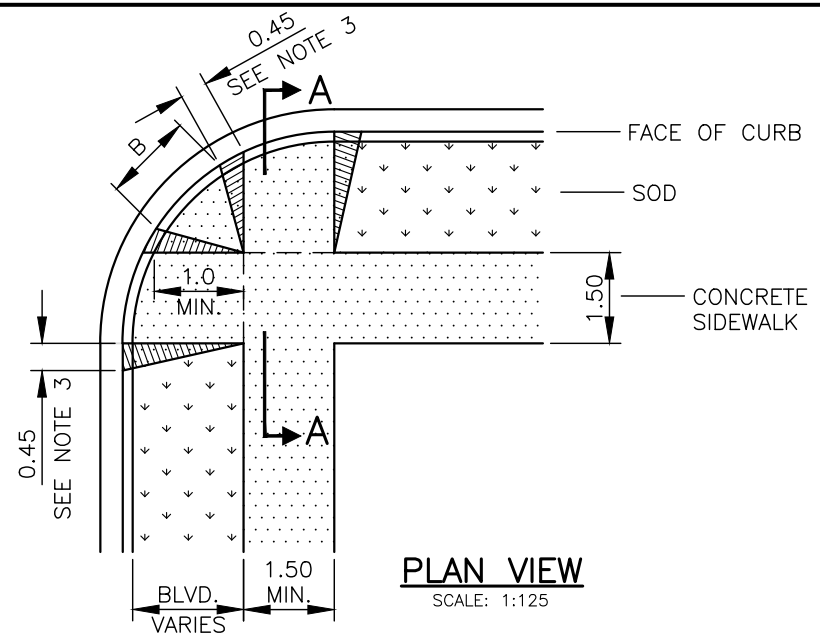
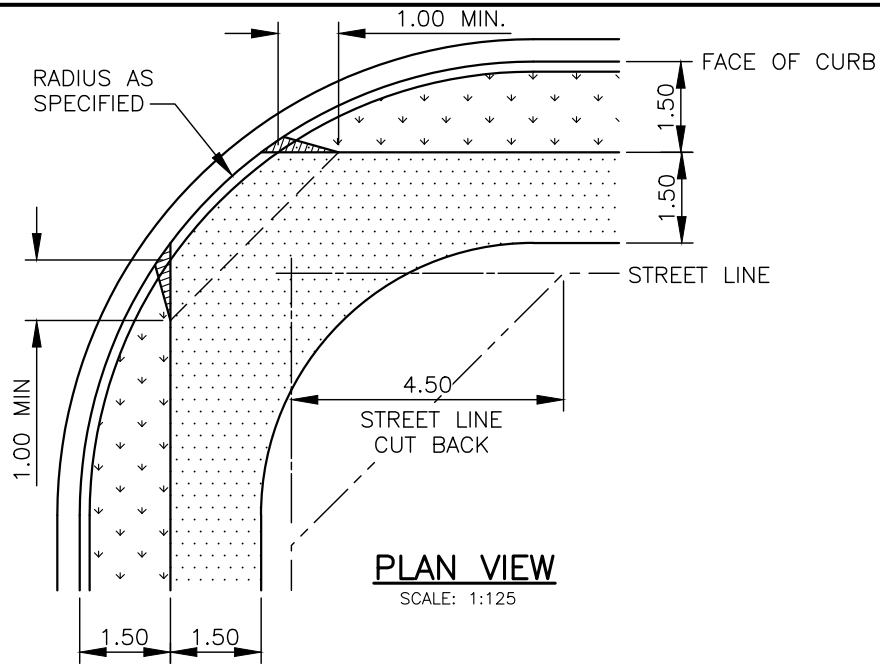

NOTES:

1. PEDESTRIAN RAMPS SHALL BE ALIGNED WITH THE SIDEWALK INSIDE EDGE.
2. INSTALL RAMP DIVIDER ONLY WHEN (B) WILL BE GREATER THAN 0.45 m.
3. WHERE THE BOULEVARD IS LESS THAN 1.5 m, A 1.3 m CURB TRANSITION TAPER IS REQUIRED.
4. IF THE DISTANCE FROM BACK OF CURB TO BACK OF SIDEWALK IS LESS THAN 2 m, SLOPE AT 5% FROM BACK OF CURB TO BACK OF SIDEWALK.
5. TACTILE WALKING SURFACE INDICATOR PLATES REQUIRED AT ALL NEW RAMPS AS PER HRM DETAIL 131.
6. FOR STREETS OF LESS THAN 8%, TRANSITION CURB AND SIDEWALK TO MAXIMUM GRADE OF 8%, OR TIE IN AT 3 m. FOR SIDEWALK, 1.3 m FOR CURB.
7. PEDESTRIAN RAMP OPENING TO BE 1.7 m MINIMUM, MEASURED FROM 0.1 m BEYOND THE EXTENSION OF THE SIDEWALK TO THE CURB.
8. DIMENSIONS ARE IN METRES UNLESS OTHERWISE NOTED.

HALIFAX

STANDARD DETAIL

PEDESTRIAN RAMP
ALIGNMENT

| | | |
|--------------------|-----------|--------------------|
| DATE: 2021 | REFERENCE | APPROVED |
| SCALE: AS NOTED | | FIG No.: HRM 49 |

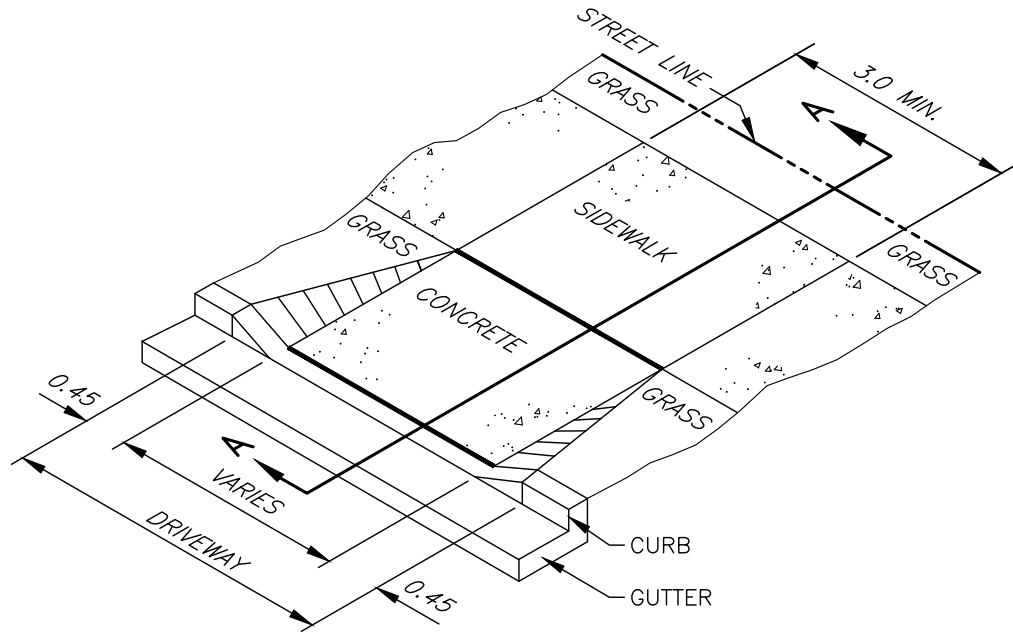

VIEW PLAN

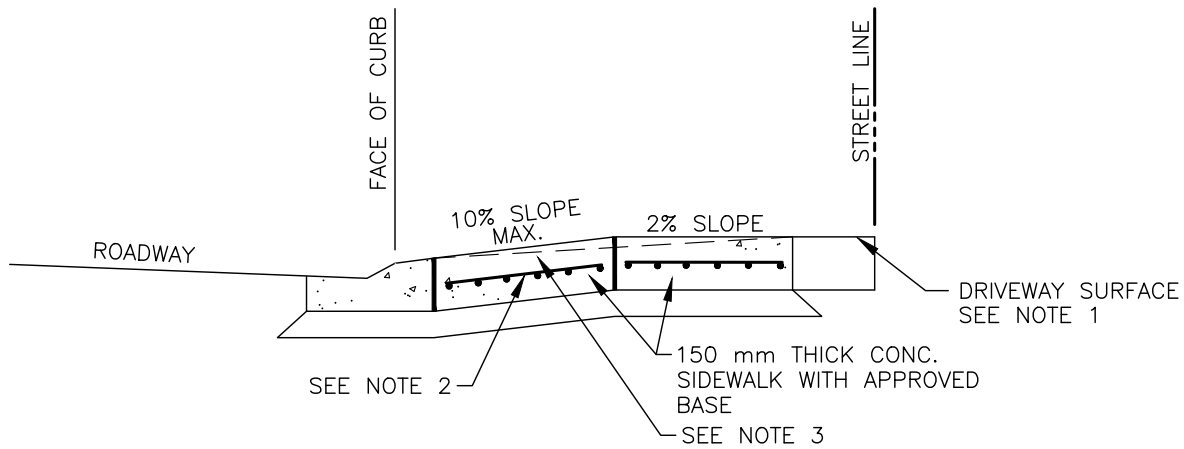

SECTION A-A

NOTES:

1. GRAVEL DRIVEWAYS ARE TO BE PAVED 1 m BEHIND THE SIDEWALK OR TO THE STREETLINE WHICHEVER IS LESS. IF NO SIDEWALK EXISTS, 1 m ASPHALT PAVING IS REQUIRED.
2. FOR COMMERCIAL AND INDUSTRIAL DRIVEWAYS PLACE 150 x 150 – M.W. 18.7 x M.W. 18.7 PLACED 50 mm FROM BOTTOM OF CONCRETE RAMP AND SIDEWALK.
3. WHEN BOULEVARD IS LESS THAN 1.5 m OR WHEN THE SIDEWALK ABUTS THE CURB & GUTTER, REFER TO HRM 133.
4. MINIMUM DISTANCE BETWEEN CONTROL JOINTS IS 1.2. PROVIDE CONTROL JOINTS WITHIN 150 mm OF CHANGE IN CROSS SECTION OF CURB.
5. DIMENSIONS ARE IN METRES UNLESS OTHERWISE NOTED.

HALIFAX

STANDARD DETAIL

DRIVEWAY RAMP

| | | | |
|--------|------|-----------|---------------------------|
| DATE: | 2021 | REFERENCE | APPROVED |
| SCALE: | NTS | | FIG No.: HRM 50 |

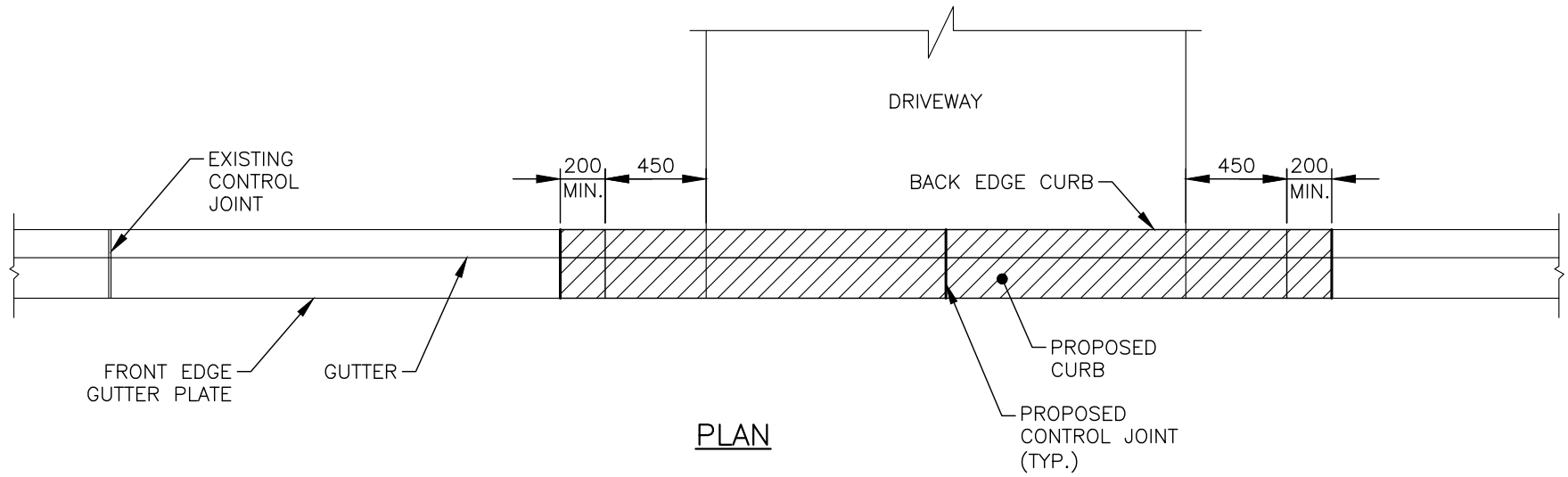

PLAN

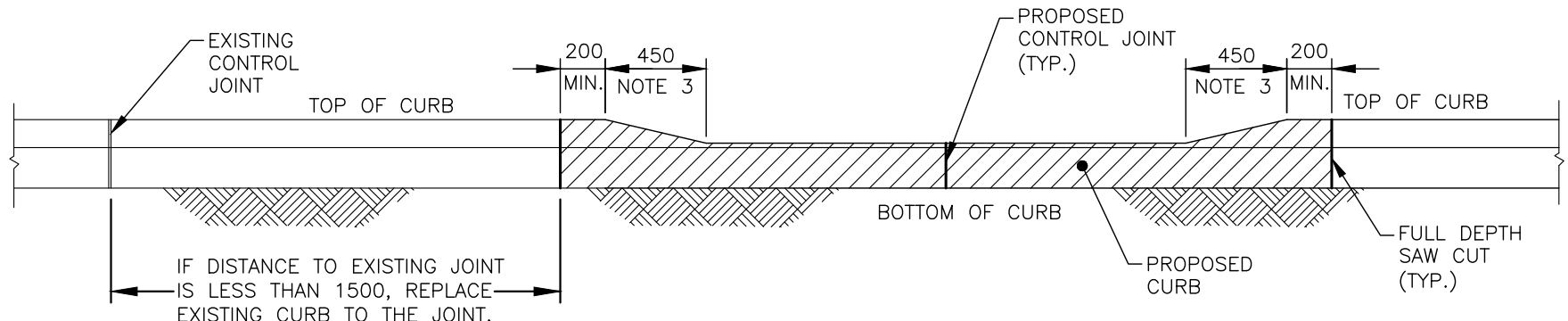

ELEVATION

NOTES:

1. MINIMUM DISTANCE BETWEEN CONTROL JOINTS IS 1200 mm.
2. PROVIDE CONTROL JOINTS WITHIN 150 mm OF CHANGE IN CROSS SECTION OF CURB.
3. IF SIDEWALK ABUTS THE CURB, THE TAPER SHALL BE 1300 mm.
4. DIMENSIONS ARE IN MILLIMETRES.

HALIFAX

STANDARD DETAIL

**DRIVEWAY ACCESS IN
EXISTING FULL-DEPTH CURB**

| | | |
|----------------|-----------|---------------------------|
| DATE: 2021 | REFERENCE | APPROVED |
| SCALE: 1:30 | | FIG No.: HRM 51 |

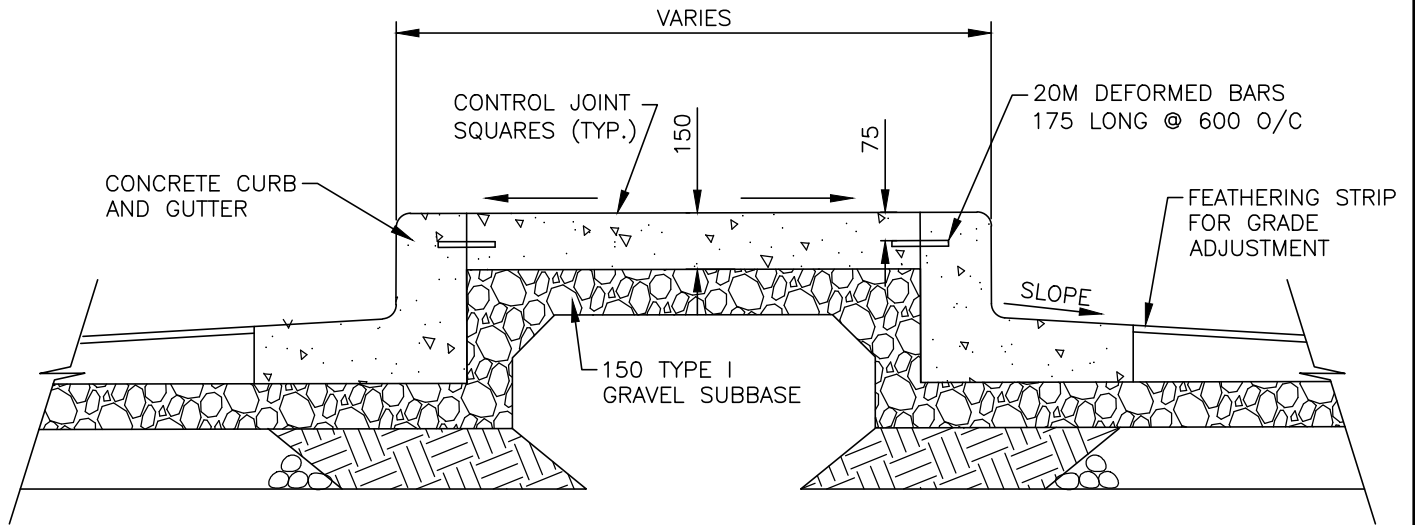

TYPICAL CONCRETE ISLAND CROSS SECTION

NOTES:

1. MAXIMUM SPACING FOR CONTROL JOINTS IS TO BE 2.5 m.
2. SLOPE SLAB TO FACILITATE DRAINAGE.
3. SLOPE GUTTER TO MATCH STREET CROSS SECTION.
4. ENDS AND CORNERS OF TRAFFIC ISLANDS TO HAVE HIGH BACK CONCRETE CURB AND GUTTER.
5. GEOMETRIC DESIGN OF CONCRETE ISLANDS TO BE AS PER PART A OF THE MUNICIPAL DESIGN GUIDELINES AND/OR THE TAC GEOMETRIC DESIGN GUIDE.
6. DIMENSIONS ARE IN MILLIMETRES.

HALIFAX

STANDARD DETAIL

**CONCRETE
TRAFFIC ISLAND**

| | | | |
|--------|------|-----------|---------------------------|
| DATE: | 2021 | REFERENCE | APPROVED |
| SCALE: | 1:20 | | FIG No.: HRM 52 |

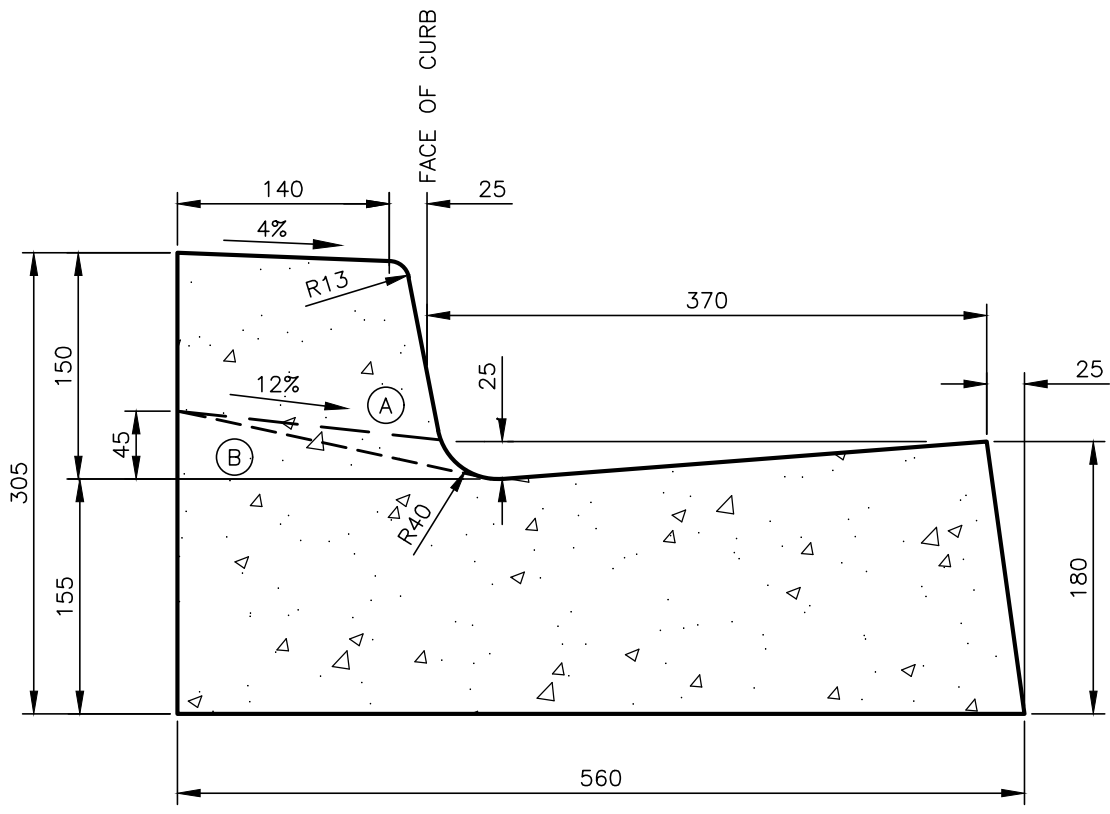

CURB & GUTTER SECTION

NOTES:

1. DASHED LINE "A" INDICATES CURB AT DRIVEWAYS.
2. DASHED LINE "B" INDICATES CURB AT PEDESTRIAN RAMPS.
3. TRANSITION TAPERS SHALL BE PROVIDED AT DRIVEWAYS AND PEDESTRIAN RAMPS AS PER THE "PEDESTRIAN RAMP ALIGNMENT" DETAIL AND "DRIVEWAY RAMP" DETAIL.
4. DIMENSIONS ARE IN MILLIMETRES UNLESS OTHERWISE NOTED.

| | | |
|---------------------------|-----------|----------|
| HALIFAX | | |
| STANDARD DETAIL | | |
| CONCRETE CURB & GUTTER | | |
| DATE: | REFERENCE | APPROVED |
| 2021 | | |
| SCALE: | | FIG No.: |
| 1:5 | | HRM 53 |

2 mm x 50 mm REINSTATEMENT TAPE (m)
(REQUIRED IF STREET IS
NOT BEING RESURFACED)

CURB & GUTTER PAYMENT INCLUDES
150 mm TYPE 1 GRANULAR BASE

SOD

TOP LIFT ASPHALTIC CONCRETE

600 mm

TYPICAL PAVEMENT WIDTH FOR
ASPHALT AND GRAVELS FOR
CURB RENEWAL SITUATIONS

150 mm

BASE LIFT ASPHALTIC CONCRETE

TYPE 1 GRAVEL (m²)

TYPE 2 GRAVEL (m²)

TYPE 2 GRAVEL (m²)

1
2

1
2

NOTES:

1. CURB AND GUTTER PAYMENT INCLUDES A GRANULAR BASE OF 150 mm OF TYPE 1 GRAVEL, OR AS INDICATED ON DRAWINGS.
2. PAVEMENT STRUCTURE THICKNESS AS INDICATED ON DRAWINGS.

HALIFAX

STANDARD DETAIL

CURB RENEWAL/PAYMENT

| | | | |
|--------|------|-----------|---------------------------|
| DATE: | 2021 | REFERENCE | APPROVED |
| SCALE: | 1:10 | | FIG No.: HRM 54 |

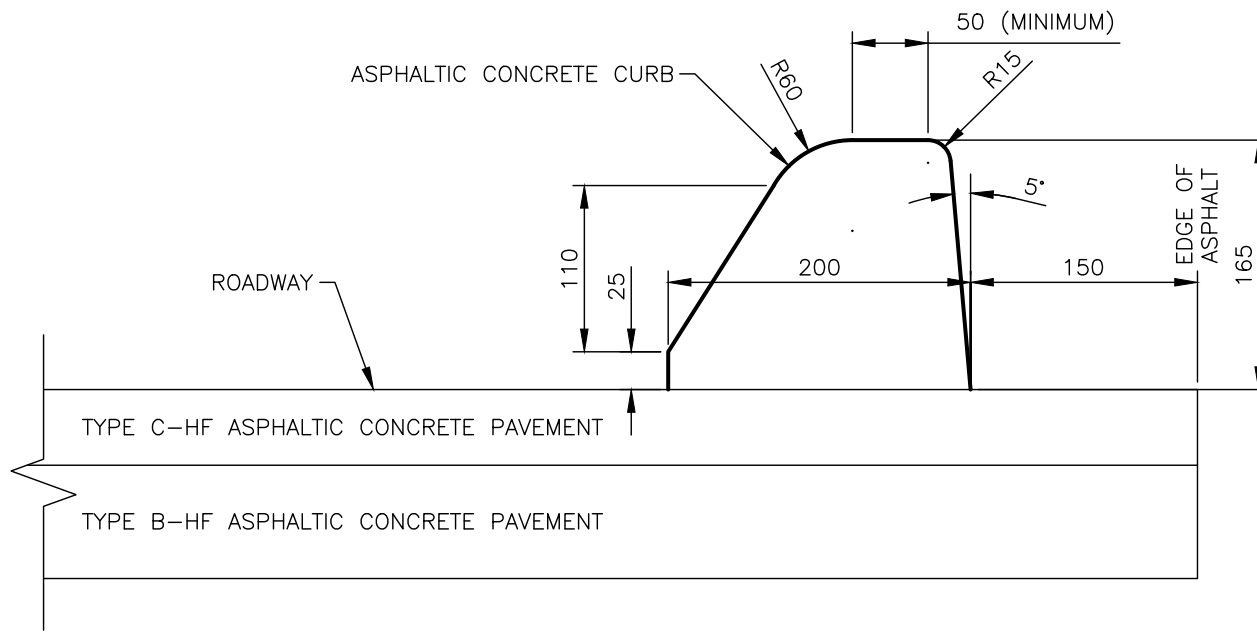

HALIFAX

STANDARD DETAIL

ASPHALT CURB

| | | | |
|--------|------|-----------|----------|
| DATE: | 2021 | REFERENCE | APPROVED |
| SCALE: | 1:5 | FIG No.: | HRM 55 |

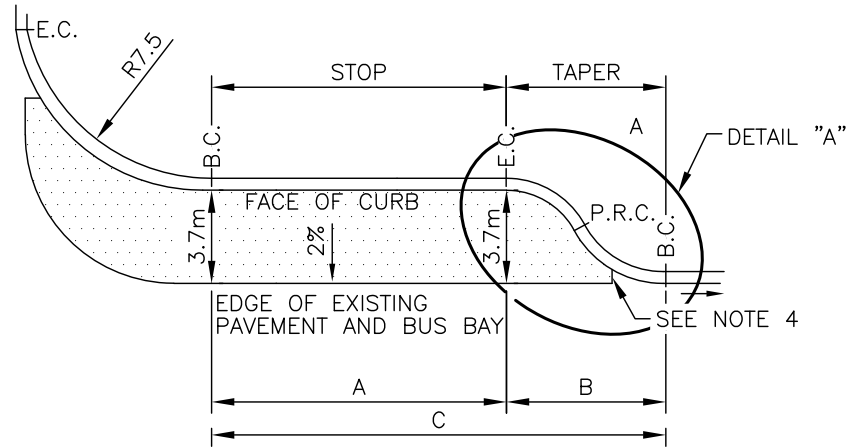

PLAN

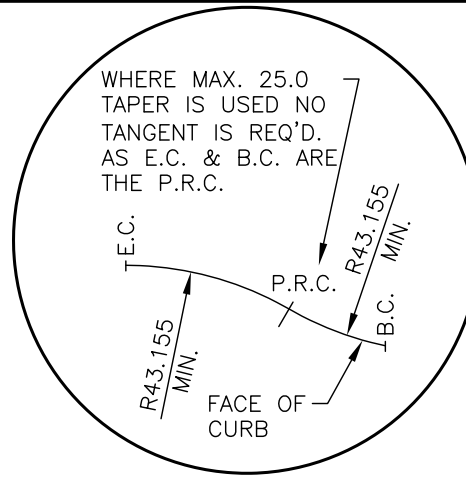

DETAIL "A"

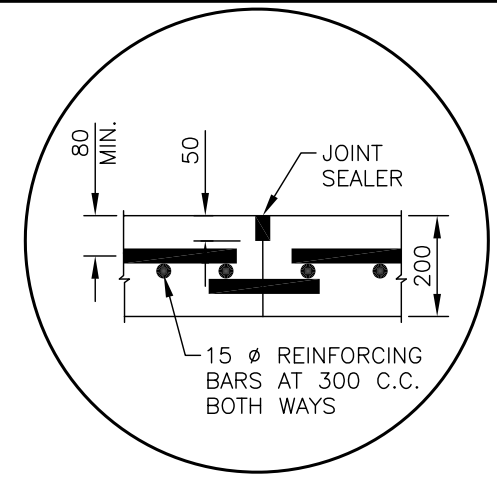

DETAIL "B"
(CONTRACTION JOINT)

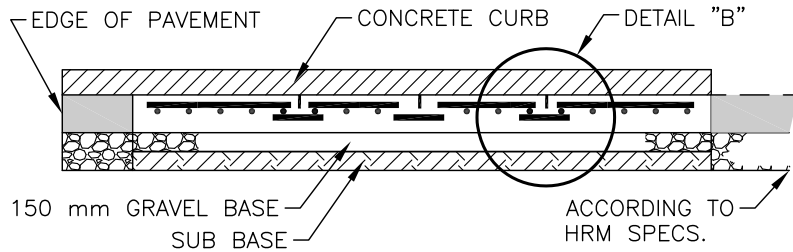

LONGITUDINAL SECTION

| | SINGLE BUS BAY (MINIMUM DIMENSION) | DOUBLE BUS BAY (MINIMUM DIMENSION) |
|---|---------------------------------------|---------------------------------------|
| A | *16m | 34m |
| B | 25m | 25m |
| C | 41m | 59m |

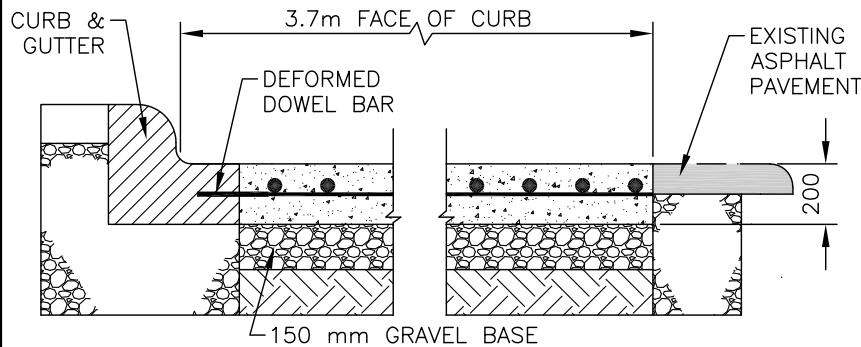

TRANSVERSE SECTION

NOTES:

- 15M BARS AT 300 mm C.C. BOTH WAYS.
- CONTROL JOINTS TO BE AT A DEPTH OF 1/4 OF PAD THICKNESS & SEALED ACCORDING TO HRM SPECS.
- CONTROL JOINT EVERY 4.0 m MAXIMUM.
- MINIMUM WIDTH OF CONCRETE BASE IS 0.6 m.
- *FOR ARTICULATED BUS ROUTES INCREASE TO 22m.
- ALL DIMENSIONS ARE IN MILLIMETRES UNLESS OTHERWISE NOTED.

HALIFAX

STANDARD DETAIL

CONCRETE BUS BAY
PAD – END BLOCK

| | | | |
|--------|------|-----------|--------------------|
| DATE: | 2024 | REFERENCE | APPROVED |
| SCALE: | NTS | | FIG No.: HRM 57 |

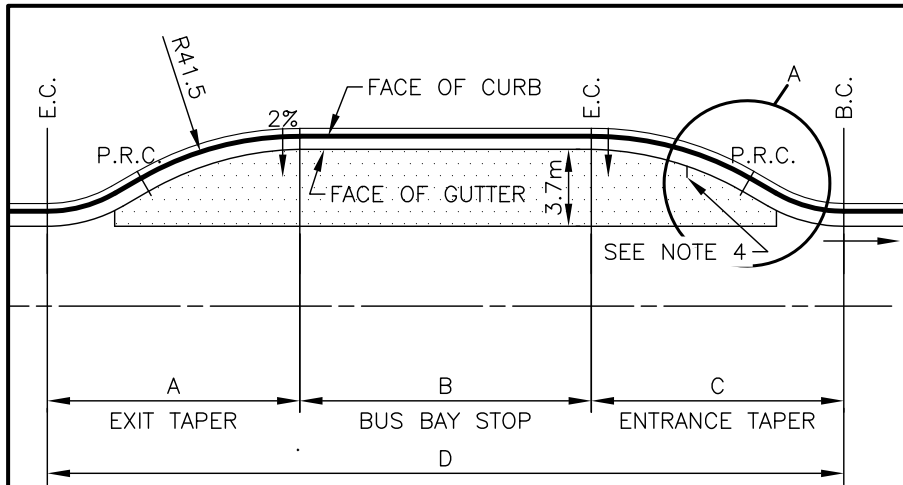

PLAN

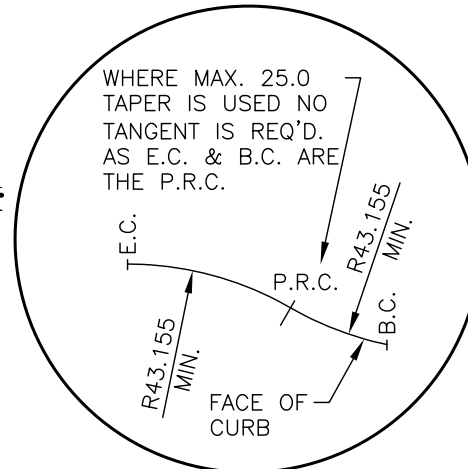

DETAIL "A"

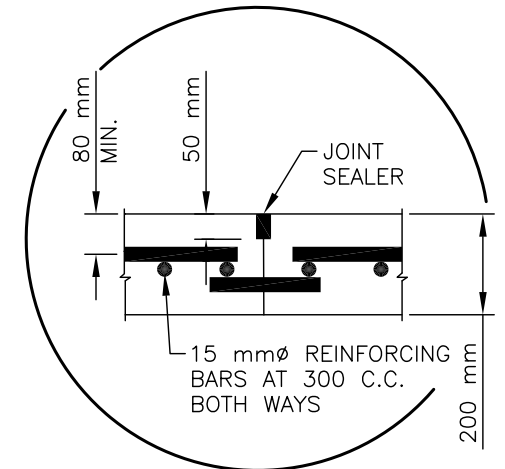

DETAIL "B"
(CONTRACTION JOINT)

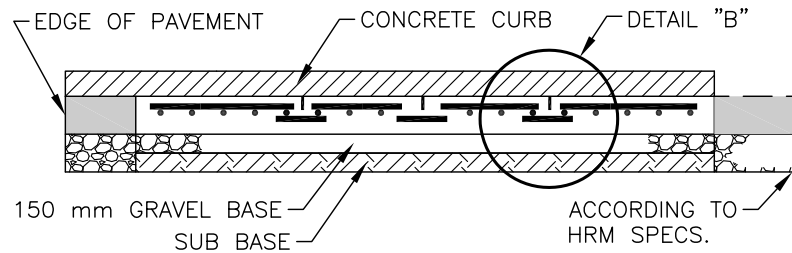

LONGITUDINAL SECTION

| | SINGLE BUS BAY MINIMUM DIMENSION | DOUBLE BUS BAY MINIMUM DIMENSION |
|---|-------------------------------------|-------------------------------------|
| A | 25m | 25m |
| B | *16m | 34m |
| C | 25m | 25m |
| D | 66m | 84m |

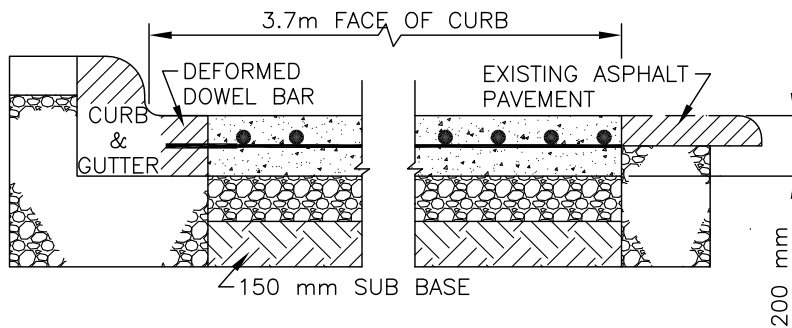

TRANSVERSE SECTION

NOTES:

- 15M BARS AT 300 mm C.C. BOTH WAYS.
- CONTROL JOINTS TO BE AT A DEPTH OF 1/4 OF PAD THICKNESS & SEALED ACCORDING TO HRM SPECS. CONTROL JOINT EVERY 4.0 m MAXIMUM.
- MINIMUM WIDTH OF CONCRETE BASE IS 0.6 m.
- *FOR ARTICULATED BUS ROUTES INCREASE TO 22m.
- ALL DIMENSIONS ARE IN MILLIMETRES UNLESS OTHERWISE NOTED.

HALIFAX

STANDARD DETAIL

CONCRETE BUS BAY
PAD – MID BLOCK

| | | | |
|--------|------|-----------|----------|
| DATE: | 2024 | REFERENCE | APPROVED |
| SCALE: | NTS | FIG No.: | HRM 58 |

TRENCH BACKFILL AND REINSTATEMENT – TESTING REQUIREMENTS

| TEST REQUIRED | COMPACTION REQUIRED | MINIMUM TEST FREQUENCY | |
|--|---|---|--|
| | | TRENCH LESS THAN 1.5m WIDE | TRENCH GREATER THAN 1.5m WIDE |
| COMPACTION OF BEDDING, HAUNCH AND COVER MATERIALS (ASTM D698) *SEE NOTE 3 | 95% MINIMUM AT 3% ± OF OPTIMUM MOISTURE. (SEE NOTES) | 1 PER 25 m AT THE CENTRELINE OF THE TRENCH (AND EACH BENCH OR SECTION OF TRENCH LESS THAN 25 m IN LENGTH) FOR EACH 600 VERTICAL DEPTH OF BACKFILL MATERIAL A MINIMUM OF 3 TESTS PER TRENCH SHALL BE PERFORMED. | 3 PER 25 m (AND EACH BENCH OR SECTION OF TRENCH LESS THAN 25 m IN LENGTH) FOR EACH 600 VERTICAL DEPTH OF BACKFILL MATERIAL 1 TEST SHALL BE TAKEN AT THE CENTRELINE OF THE TRENCH (SET BACK AT LEAST 300 mm FROM THE EDGE OF THE TRENCH). A MINIMUM OF 3 TESTS PER TRENCH SHALL BE PERFORMED. |
| COMPACTION OF STRUCTURAL FILL TO SUBGRADE ELEVATION (ASTM D698) *SEE NOTE 3 | TOP 300 98% COMPACTION MINIMUM AT 3% ± OF OPTIMUM MOISTURE. (SEE NOTES) | | |
| | BELOW 300 95% COMPACTION MINIMUM AT 3% ± OF OPTIMUM MOISTURE. (SEE NOTES) | | |
| COMPACTION OF TYPE 1 & TYPE 2 BASE & SUB-BASE MATERIALS (ASTM D698) | 100% COMPACTION MINIMUM AT 3% ± OF OPTIMUM MOISTURE (SEE NOTES) | FOR EACH MATERIAL, 1 PER 25 m AT THE CENTRELINE OF THE TRENCH (AND EACH BRANCH OR SECTION OF THE TRENCH LESS THAN 25 m IN LENGTH) FOR EACH 300 VERTICAL DEPTH OF BACKFILL MATERIAL. A MINIMUM OF 3 TESTS PER TRENCH SHALL BE PERFORMED. | FOR EACH MATERIAL, 3 PER 25 m (AND EACH BRANCH OR SECTION OF TRENCH LESS THAN 25 m IN LENGTH) FOR EACH 300 VERTICAL IN DEPTH OF BACKFILL MATERIAL. 1 TESTS SHALL BE TAKEN AT THE CENTRELINE OF THE TRENCH AND 1 AT EACH EDGE OF THE TRENCH (SET BACK AT LEAST 300 mm FROM THE EDGE OF THE TRENCH). A MINIMUM OF 3 TESTS PER TRENCH SHALL BE PERFORMED. |
| COMPACTION OF HOT MIX ASPHALT PAVEMENT (ASTM D3549 & 2726) | 95% OF MAXIMUM THEORETICAL DENSITY OF COMPARATIVE MARSHALL LABORATORY SAMPLE. | ONE TEST FOR EACH 75 m ² OF PAVEMENT SURFACE. A MINIMUM OF 1 TEST PER TRENCH. | ONE TEST FOR EACH 75 m ² OF PAVEMENT SURFACE. A MINIMUM OF 1 TEST PER TRENCH. |

NOTES:

1. THE TRENCH WIDTH FOR DETERMINATION OF THE TEST SHALL BE THE WIDTH OF THE TRENCH AT THE LEVEL OF THE TEST BEING PERFORMED.
2. IF MINIMUM MOISTURE DENSITY REQUIREMENTS ARE NOT MET BY THESE TESTS, THE CONTRACTOR SHALL RECOMPACT THE TRENCH AS NEEDED TO ACHIEVE THE SPECIFIED COMPACTION. SUCH RECOMPACTION SHALL EXTEND ON BOTH SIDES OF THE FAILED TEST SECTION A DISTANCE EQUAL TO 1/2 THE DISTANCE FROM WHERE THE LAST TEST WAS TAKEN OR 50 m, WHICHEVER IS LEAST. AN ALTERNATIVE PROCEDURE WOULD BE TO MORE CLEARLY DEFINE THE LIMITS OF THE FAILED AREA TO ADDITIONAL TESTS.
3. TESTING FOR BEDDING, HAUNCH AND STRUCTURAL FILL ARE NOT ONLY REQUIRED WHEN THE TOTAL LENGTH OF TRENCH EXCEEDS 100 m, OR WHEN REQUESTED BY THE HRM INSPECTOR.

HALIFAX

STANDARD DETAIL

**TRENCH BACKFILL &
REINSTATEMENT-TESTING**

| | | | |
|--------|------|-----------|---------------|
| DATE: | 2021 | REFERENCE | APPROVED |
| SCALE: | NTS | FIG No.: | HRM 61 |

CONIFEROUS
1.8–2 m HEIGHT

DECIDUOUS
60 mm CALIPER

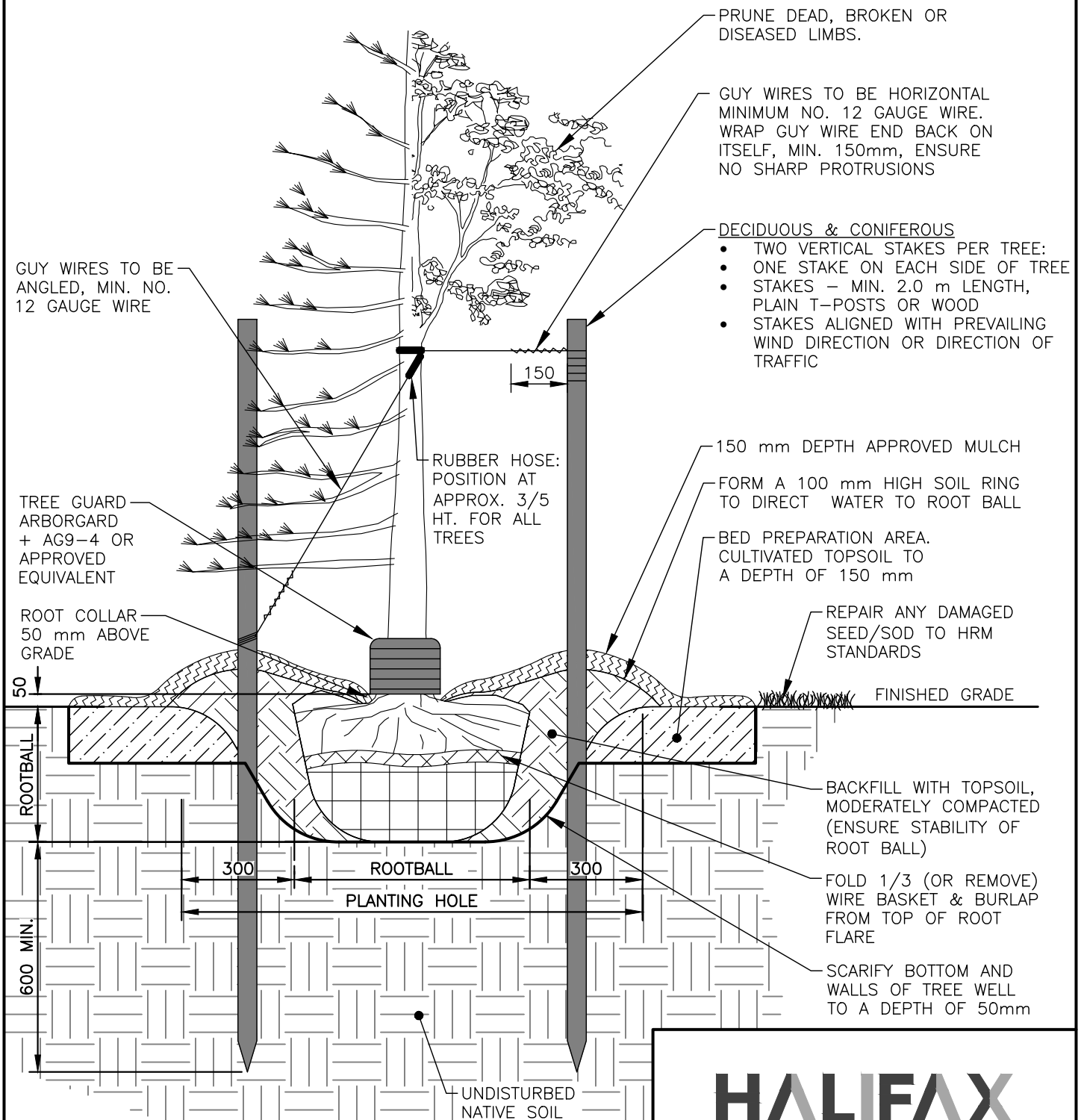

NOTES:

1. SOAK THE ROOTBALL AND BACKFILL AREA WITH 40 LITRES OF WATER AFTER PLANTING
2. CUT AND REMOVE ALL WIRE, ROPE, BURLAP AND TWINE FROM THE TOP 1/3 OF THE ROOTBALL
3. PRUNE AT PLANTING TO CAREFULLY REMOVE DEAD, BROKEN AND DAMAGED BRANCHES
4. ROOT BALL MIN. SIZE AS PER CNLA STANDARDS FOR NURSERY STOCK.
5. DIMENSIONS ARE IN MILLIMETRES UNLESS OTHERWISE NOTED.

HALIFAX

STANDARD DETAIL
TREE PLANTING
IN PARKS/OPEN SPACE

| | | | |
|--------|------|-----------|----------|
| DATE: | 2021 | REFERENCE | APPROVED |
| SCALE: | 1:15 | FIG No.: | HRM 66 |

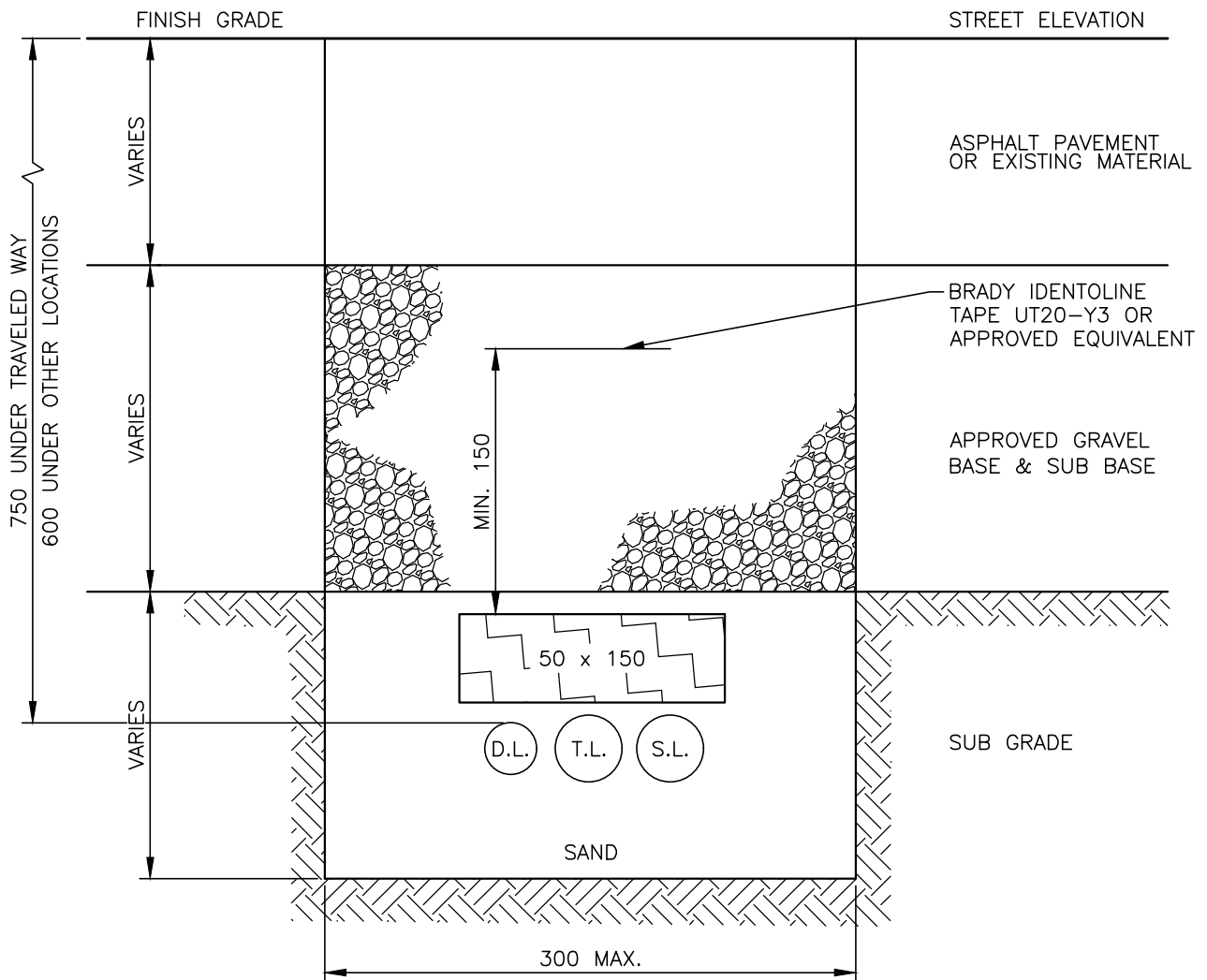

SIZE AND CONFIGURATION OF PVC CONDUIT INDICATED ON DRAWINGS

NOTES:

1. 50 mm x 150 mm WOOD PLANK TO BE PRESSURE TREATED WOOD.
2. "CAUTION BURIED ELECTRICAL LINE" TAPE TO BE PLACED OVER CONDUIT 150 mm TO 250 mm BELOW FINISHED GRADE.
3. SURROUND SAND WITH GEOTEXTILE SEPARATOR IN AREAS OF HIGH GROUNDWATER MOVEMENT (PERVIOUS SUB GRADE).

| | | |
|---------------------|-----------|----------|
| HALIFAX | | |
| STANDARD DETAIL | | |
| UNDERGROUND CONDUIT | | |
| DATE: | REFERENCE | APPROVED |
| 2021 | | |
| SCALE: | | FIG No.: |
| NTS | | HRM 78 |

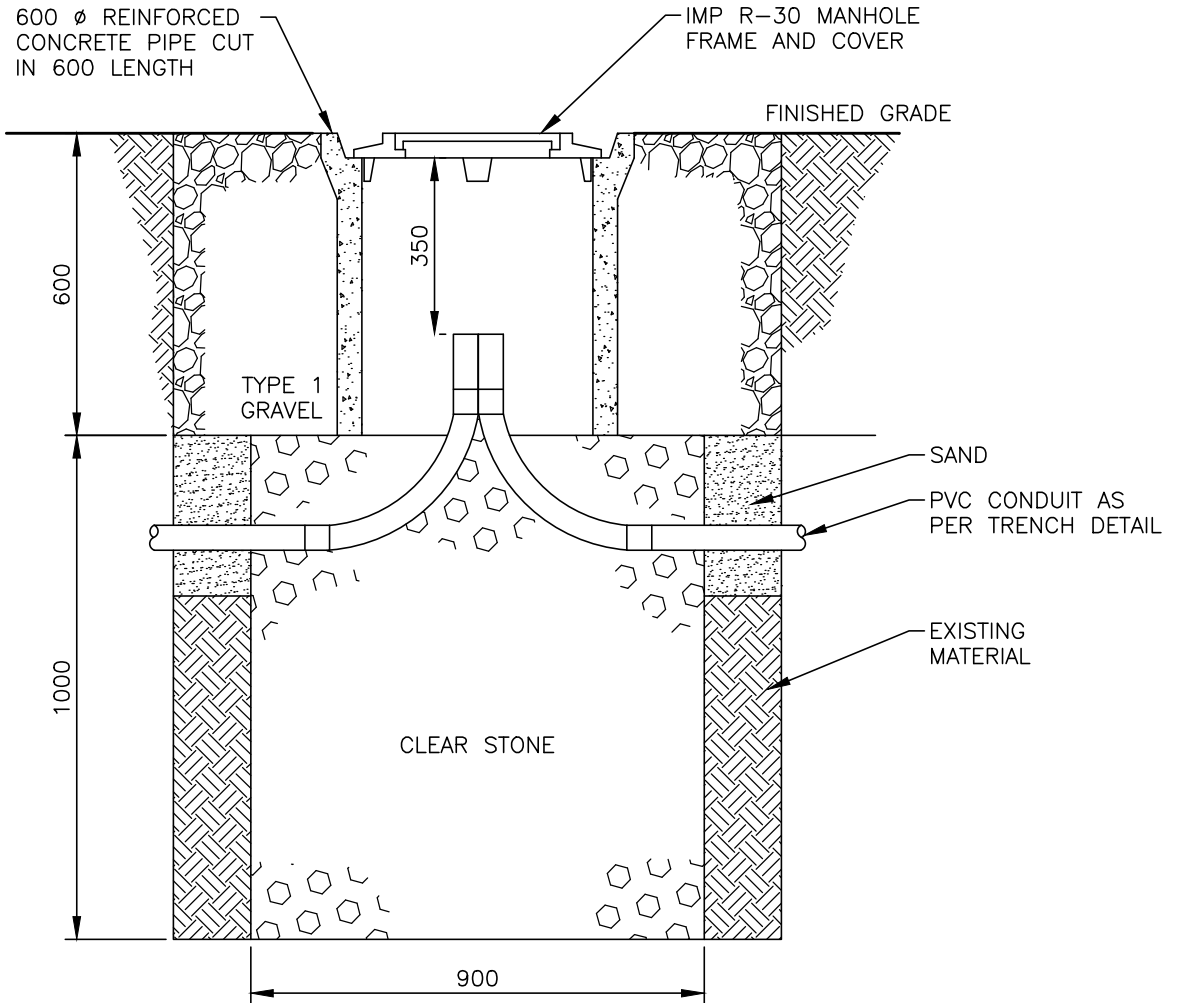

HALIFAX

STANDARD DETAIL

PULL PIT

| | | | |
|--------|------|-----------|--------------------|
| DATE: | 2021 | REFERENCE | APPROVED |
| SCALE: | 1:15 | | FIG No.: HRM 79 |

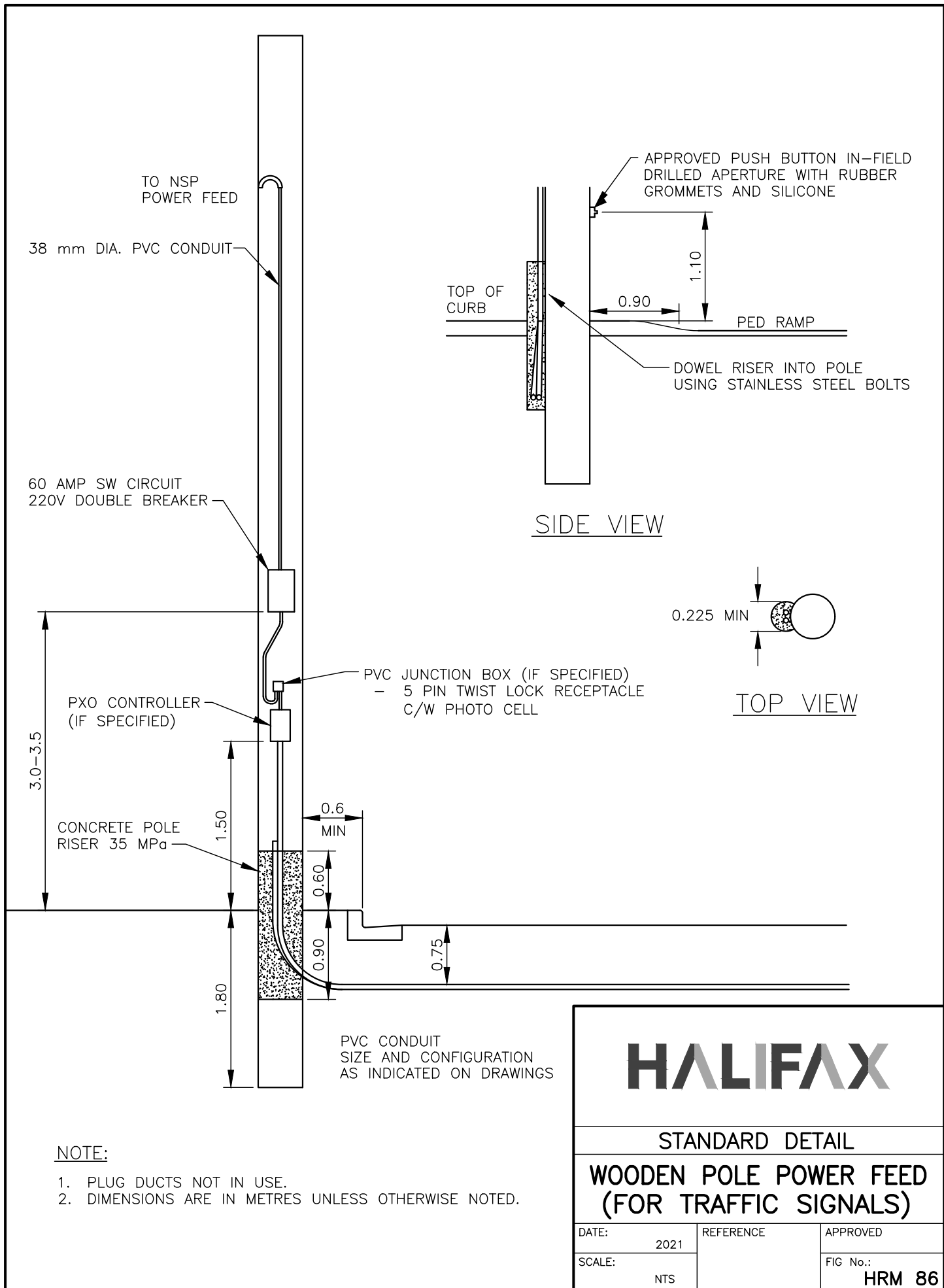

TO NSP
POWER FEED

38 mm DIA. PVC CONDUIT

60 AMP SW CIRCUIT
220V DOUBLE BREAKER

PXO CONTROLLER
(IF SPECIFIED)

CONCRETE POLE
RISER 35 MPa

PVC JUNCTION BOX (IF SPECIFIED)
- 5 PIN TWIST LOCK RECEPTACLE
C/W PHOTO CELL

APPROVED PUSH BUTTON IN-FIELD
DRILLED APERTURE WITH RUBBER
GROMMETS AND SILICONE

TOP OF
CURB

PED RAMP

DOWEL RISER INTO POLE
USING STAINLESS STEEL BOLTS

SIDE VIEW

TOP VIEW

3.0-3.5

1.50

0.6
MIN

0.60

0.90

1.80

0.75

PVC CONDUIT
SIZE AND CONFIGURATION
AS INDICATED ON DRAWINGS

0.225 MIN

HALIFAX

STANDARD DETAIL

**WOODEN POLE POWER FEED
(FOR TRAFFIC SIGNALS)**

| | | |
|---------------|-----------|--------------------|
| DATE: 2021 | REFERENCE | APPROVED |
| SCALE: NTS | | FIG No.: HRM 86 |

NOTE:

1. PLUG DUCTS NOT IN USE.
2. DIMENSIONS ARE IN METRES UNLESS OTHERWISE NOTED.

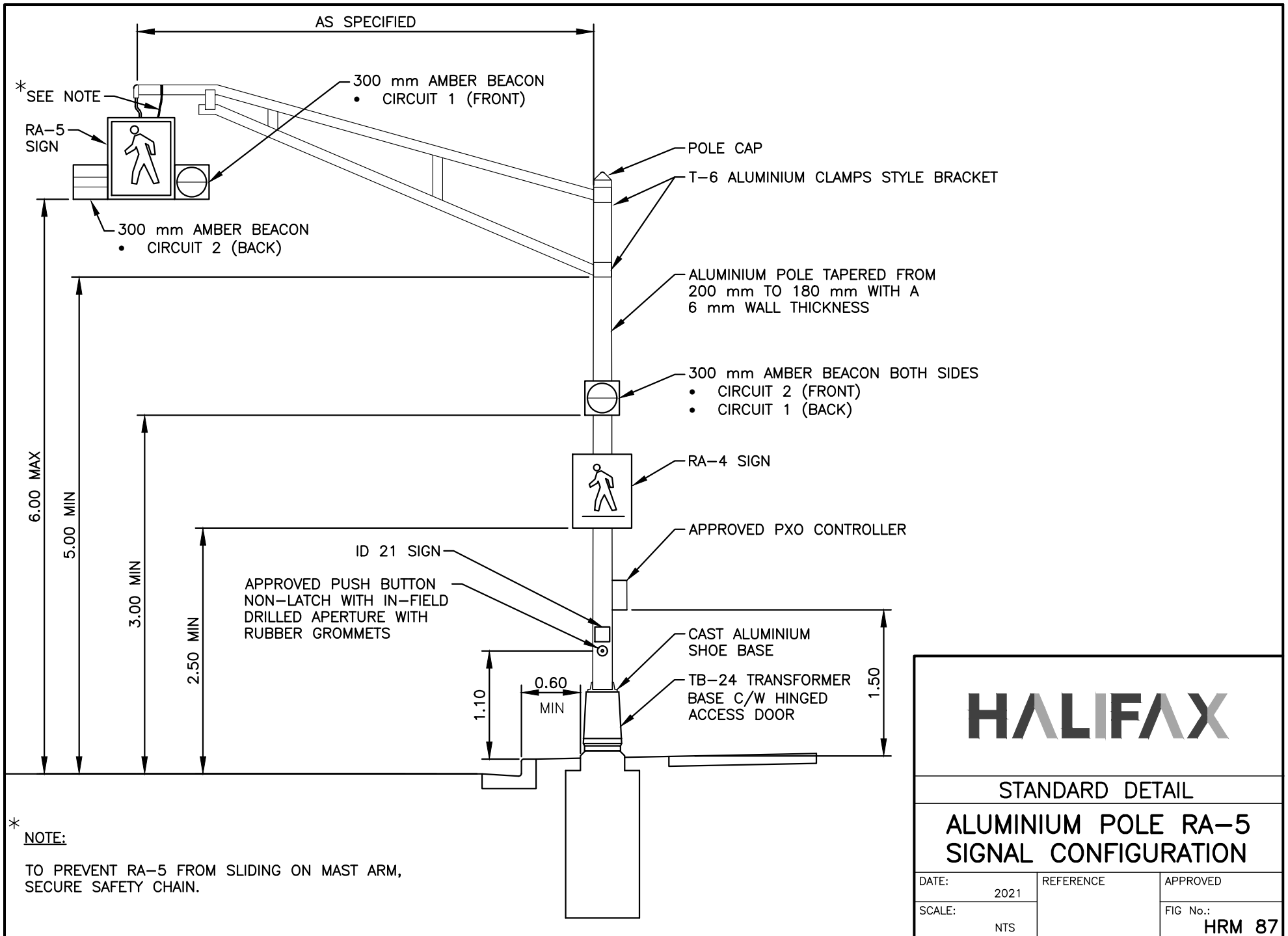

HALIFAX

STANDARD DETAIL

ALUMINIUM POLE RA-5 SIGNAL CONFIGURATION

| | | | |
|--------|------|-----------|----------|
| DATE: | 2021 | REFERENCE | APPROVED |
| SCALE: | NTS | FIG No.: | HRM 87 |

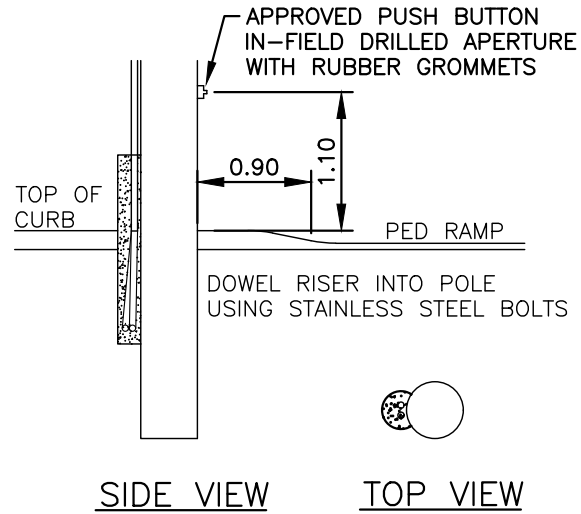
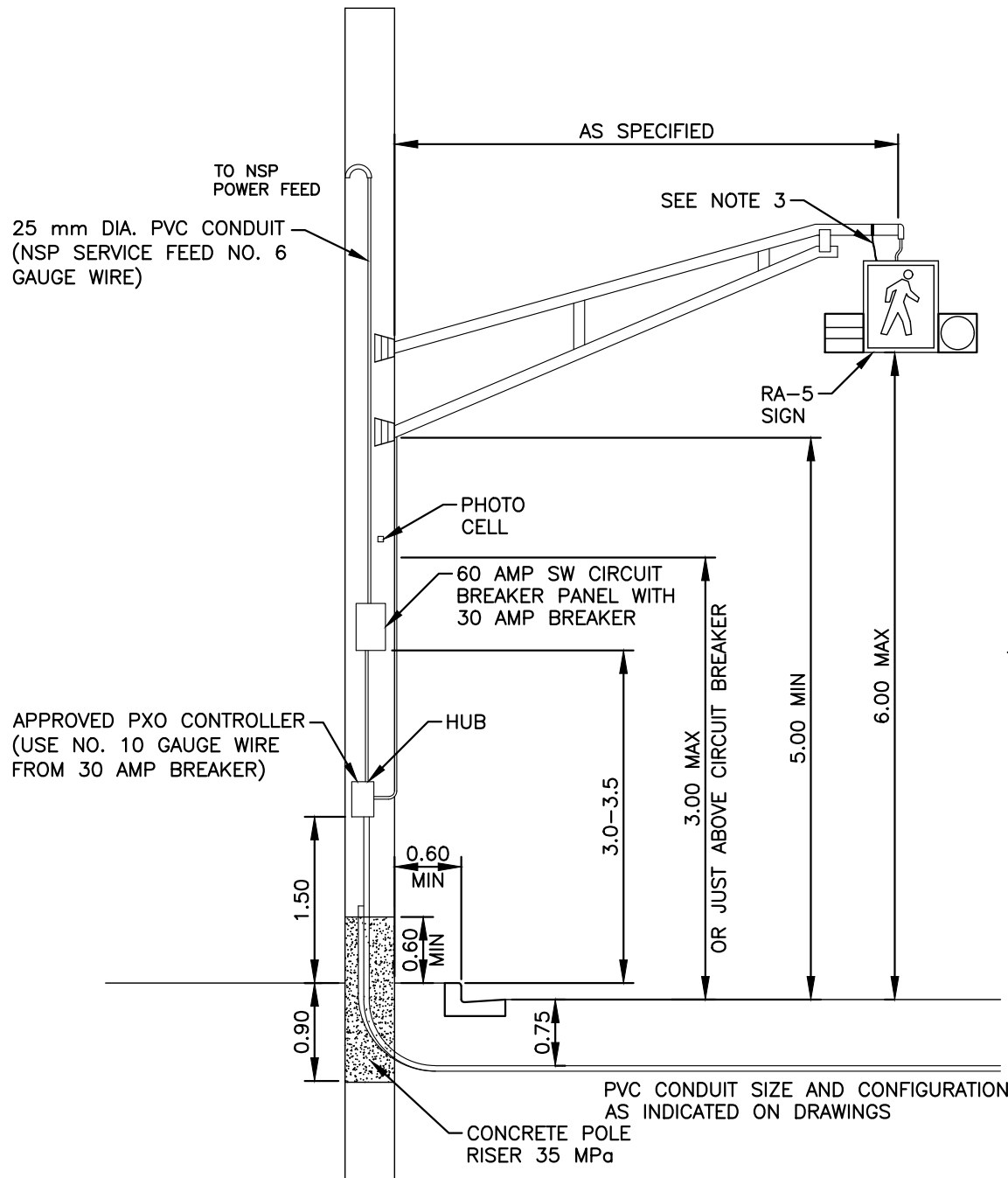

NOTES:

1. PLUG DUCTS NOT IN USE
2. INSTALL MUTCD ID21 SIGN JUST ABOVE PUSH BUTTON
3. TO PREVENT RA-5 FROM SLIDING ON MAST ARM, SECURE SAFETY CHAIN.
4. DIMENSIONS ARE IN METRES UNLESS OTHERWISE NOTED.

HALIFAX

STANDARD DETAIL
WOODEN POLE RA-5
TRAFFIC SIGNAL WITH POWER
FEED CONFIGURATION

| | | | |
|--------|------|-----------|----------|
| DATE: | 2021 | REFERENCE | APPROVED |
| SCALE: | NTS | FIG No.: | HRM 88 |

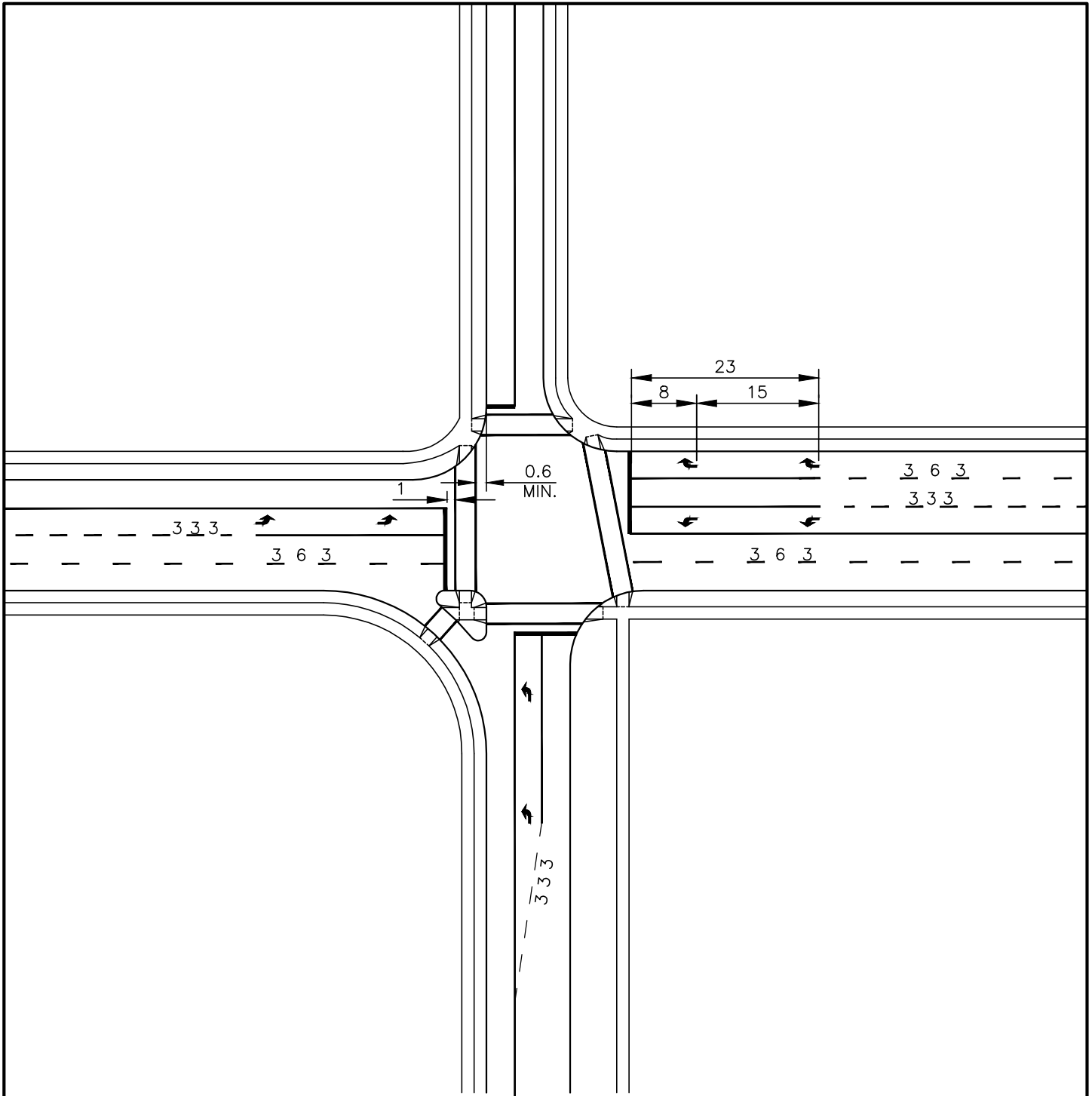

NOTES:



1. ALL PAVEMENT MARKINGS SHALL BE IN ACCORDANCE WITH HRM STANDARD DETAILS.
2. WHEN REQUIRED, THIRD AND SUBSEQUENT ARROWS TO BE SPACED AT 15.0 m INTERVALS.



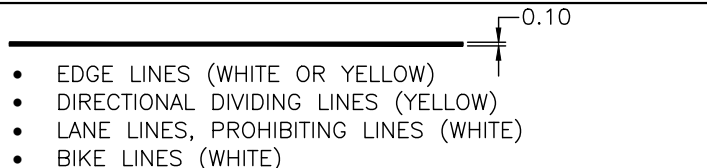
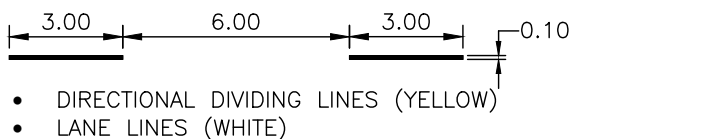
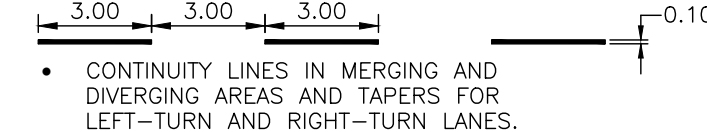
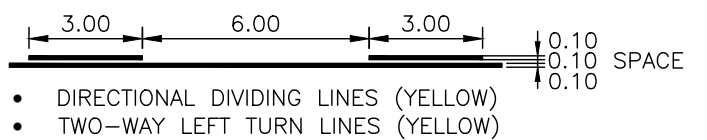

HALIFAX

STANDARD DETAIL

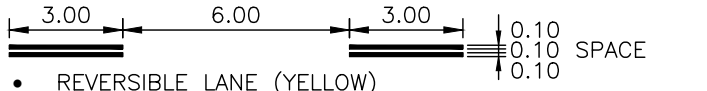
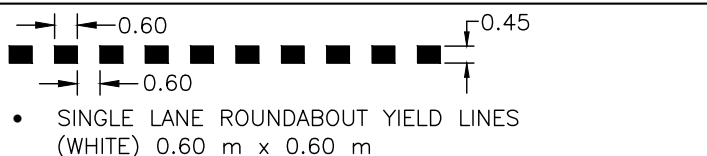
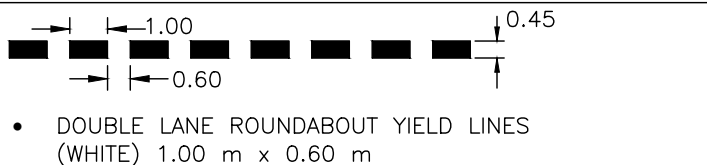
STANDARD INTERSECTION PAVEMENT MARKING LAYOUT

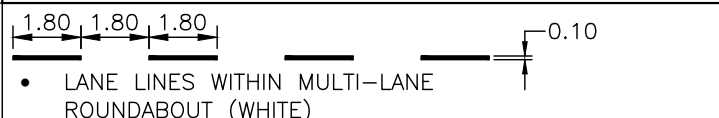
| | | | |
|--------|------|-----------|--------------------|
| DATE: | 2021 | REFERENCE | APPROVED |
| SCALE: | NTS | | FIG No.: HRM 89 |

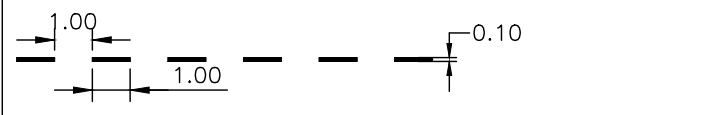
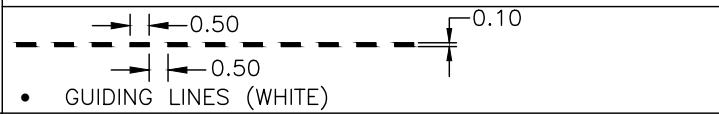
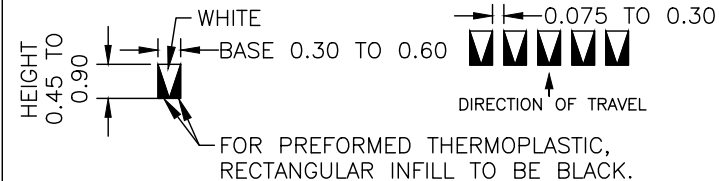
| NAME OF LINE | |
|-----------------------------|---|
| SOLID |  <ul style="list-style-type: none"> EDGE LINES (WHITE OR YELLOW) DIRECTIONAL DIVIDING LINES (YELLOW) LANE LINES, PROHIBITING LINES (WHITE) BIKE LINES (WHITE) |
| 3 m x 6 m BROKEN |  <ul style="list-style-type: none"> DIRECTIONAL DIVIDING LINES (YELLOW) LANE LINES (WHITE) |
| 3 m x 3 m |  <ul style="list-style-type: none"> CONTINUITY LINES IN MERGING AND DIVERGING AREAS AND TAPERS FOR LEFT-TURN AND RIGHT-TURN LANES. |
| SIMULTANEOUS SOLID & BROKEN |  <ul style="list-style-type: none"> DIRECTIONAL DIVIDING LINES (YELLOW) TWO-WAY LEFT TURN LINES (YELLOW) |
| DOUBLE SOLID |  <ul style="list-style-type: none"> DIRECTIONAL DIVIDING LINES (YELLOW) |
| DOUBLE BROKEN 3 m x 6 m |  <ul style="list-style-type: none"> REVERSIBLE LANE (YELLOW) |
| YIELD |  <ul style="list-style-type: none"> SINGLE LANE ROUNDABOUT YIELD LINES (WHITE) 0.60 m x 0.60 m |
| |  <ul style="list-style-type: none"> DOUBLE LANE ROUNDABOUT YIELD LINES (WHITE) 1.00 m x 0.60 m |

| NAME OF LINE | |
|------------------------------------|--|
| 1.8 m x 1.8 m |  <ul style="list-style-type: none"> LANE LINES WITHIN MULTI-LANE ROUNDABOUT (WHITE) |
| 1.5 m x 1.5 m |  <ul style="list-style-type: none"> BUS BAYS (WHITE) |
| DASHED 1.0 m x 1.0 m |  |
| 0.5 m x 0.5 m |  <ul style="list-style-type: none"> GUIDING LINES (WHITE) |
| ADVANCED YIELD TO PEDESTRIANS LINE |  <p>HEIGHT 0.45 TO 0.90</p> <p>WHITE</p> <p>BASE 0.30 TO 0.60</p> <p>0.075 TO 0.30</p> <p>DIRECTION OF TRAVEL</p> <p>FOR PREFORMED THERMOPLASTIC, RECTANGULAR INFILL TO BE BLACK.</p> |
| STOP BAR |  <ul style="list-style-type: none"> INTERSECTION STOP BAR (WHITE) |

NOTE:

1. DIMENSIONS ARE IN METRES.

HALIFAX

STANDARD DETAIL

LONGITUDINAL & TRANSVERSE
PAVEMENT MARKINGS

| | | | |
|--------|------|-----------|----------|
| DATE: | 2021 | REFERENCE | APPROVED |
| SCALE: | NTS | | FIG No.: |
| | | | HRM 90 |

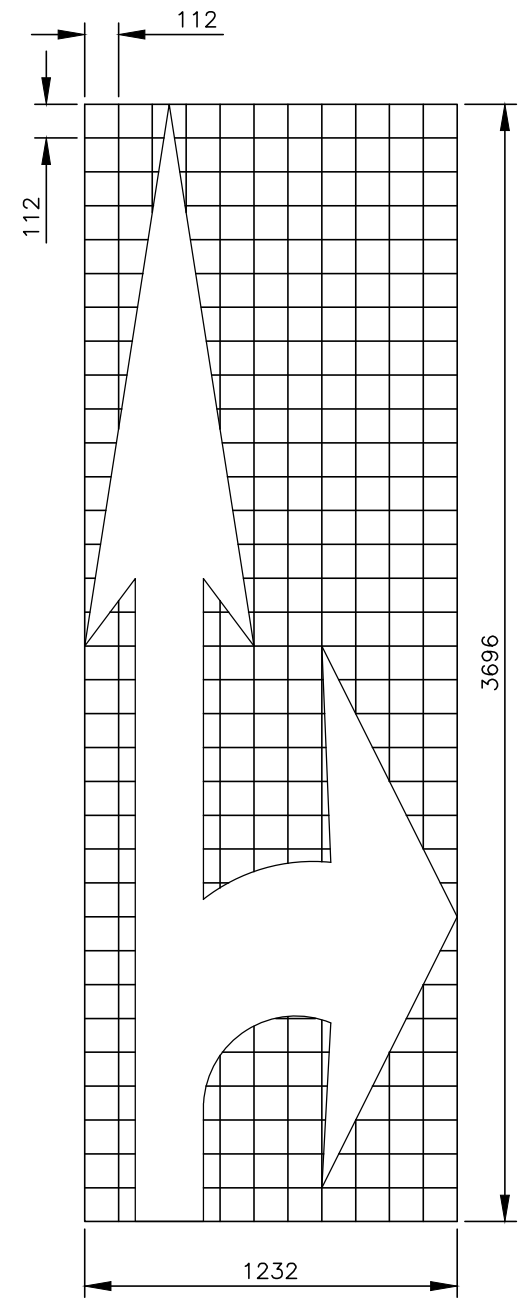
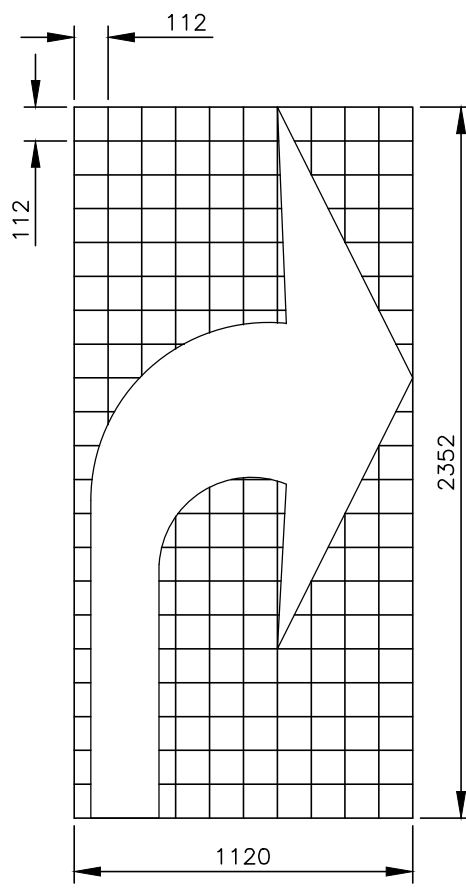
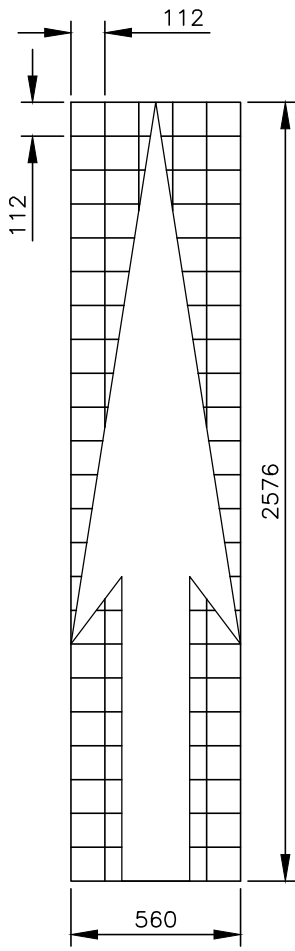

NOTE:
 1. DIMENSIONS ARE IN MILLIMETRES.

| | | |
|-----------------|------|---------------|
| HALIFAX | | |
| STANDARD DETAIL | | |
| PAVEMENT ARROWS | | |
| DATE: | 2021 | REFERENCE |
| SCALE: | 1:25 | APPROVED |
| | | FIG No.: |
| | | HRM 91 |

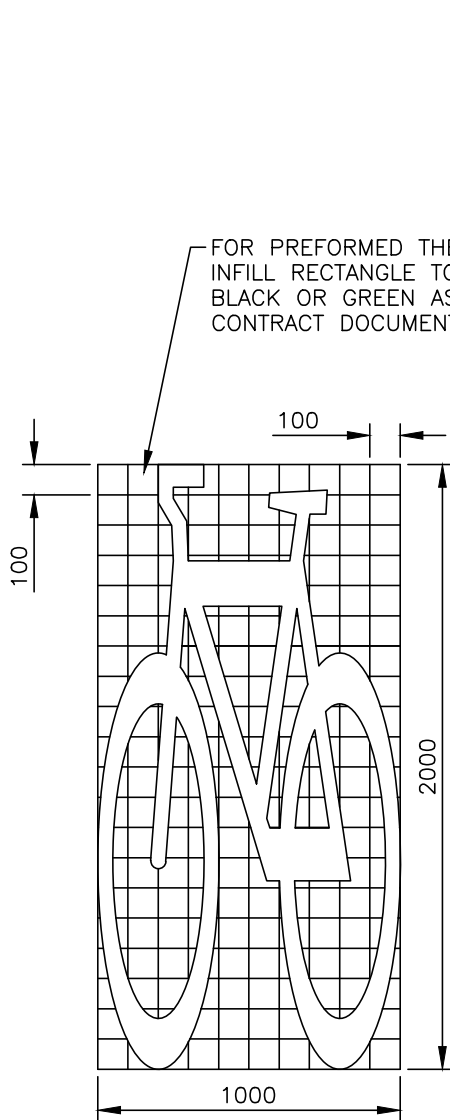

BICYCLE SYMBOL

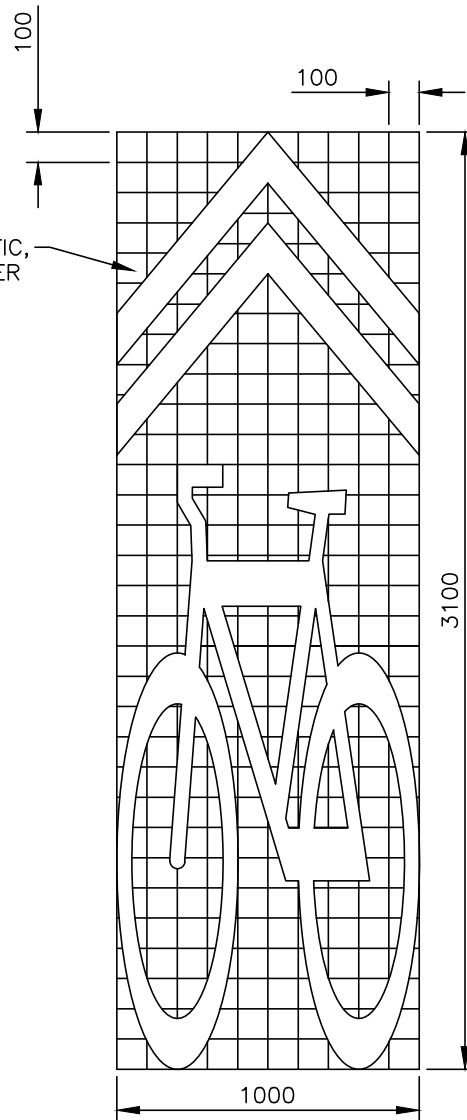

SHARED USE LANE SYMBOL

NOTE:

1. DIMENSIONS MAY BE SLIGHTLY ALTERED FOR THERMOPLASTIC IF APPROVED BY THE ENG.
2. DIMENSIONS ARE IN MILLIMETRES.

HALIFAX

STANDARD DETAIL

**BICYCLE SYMBOL &
SHARED USE LANE SYMBOL**

| | | | |
|--------|------|-----------|--------------------|
| DATE: | 2023 | REFERENCE | APPROVED |
| SCALE: | 1:25 | | FIG No.: HRM 92 |

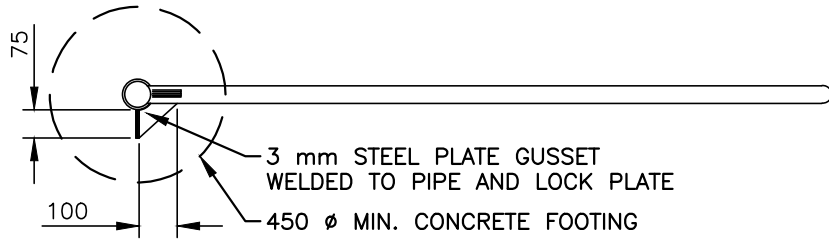

PLAN

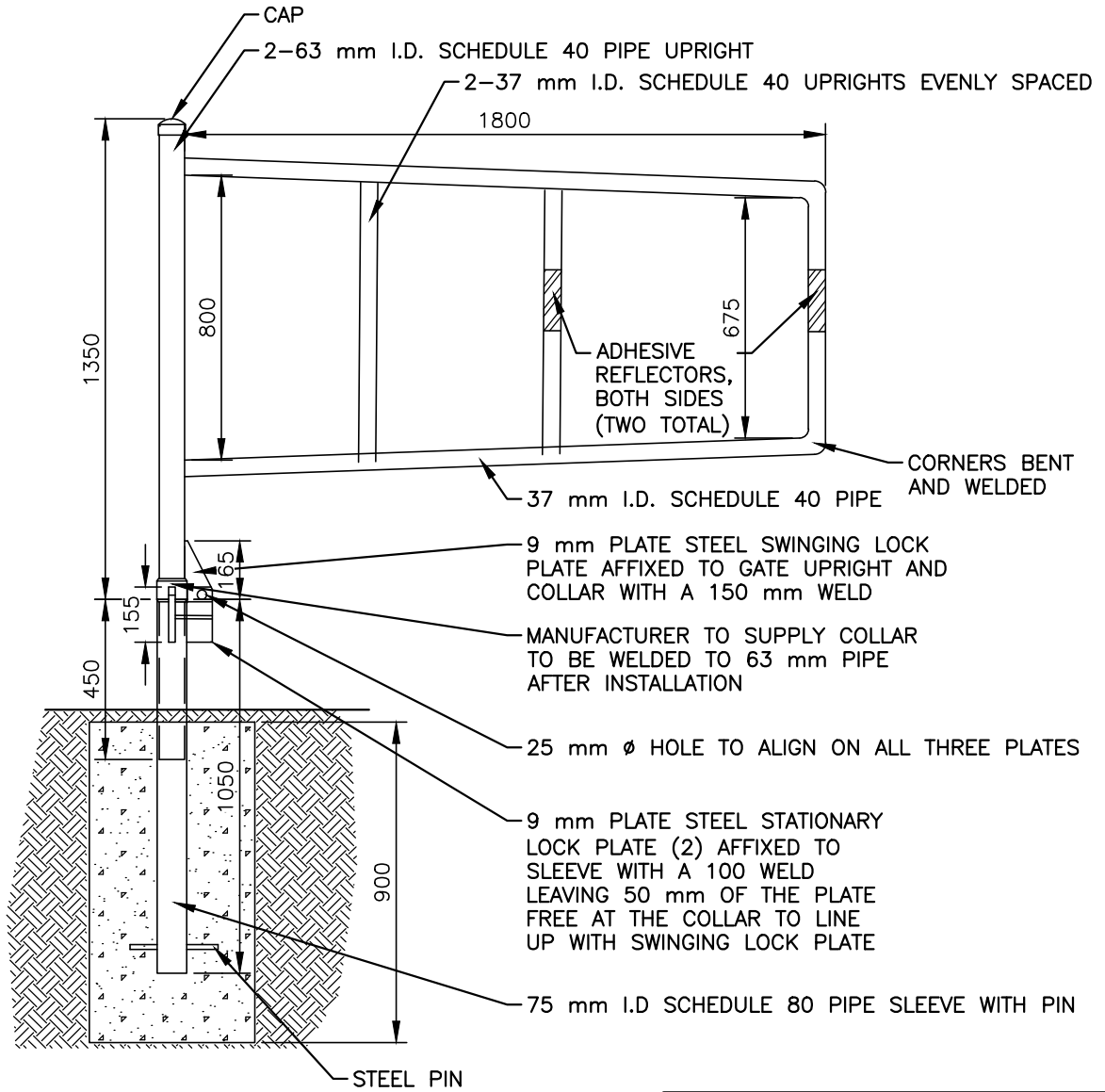

SECTION

NOTES:

1. ALL PIPE TO BE GALVANIZED EXCEPT 75 mm GROUND SLEEVE (BLACK IRON)
2. ALL WORK TO BE DONE ACCORDING TO HRM SPECIFICATIONS
3. ALL METAL TO RECEIVE ONE COAT OF RUST INHIBITING PRIMER AND TWO COATS OF R&M PAINT E1245 CODE L (HOLLY GREEN) ENAMEL AUTOMOTIVE PAINT OR EQUIVALENT.

HALIFAX

STANDARD DETAIL

PEDESTRIAN GATE

| | | | |
|--------|------|-----------|----------------------------|
| DATE: | 2023 | REFERENCE | APPROVED |
| SCALE: | NTS | | FIG No.: HRM 119 |

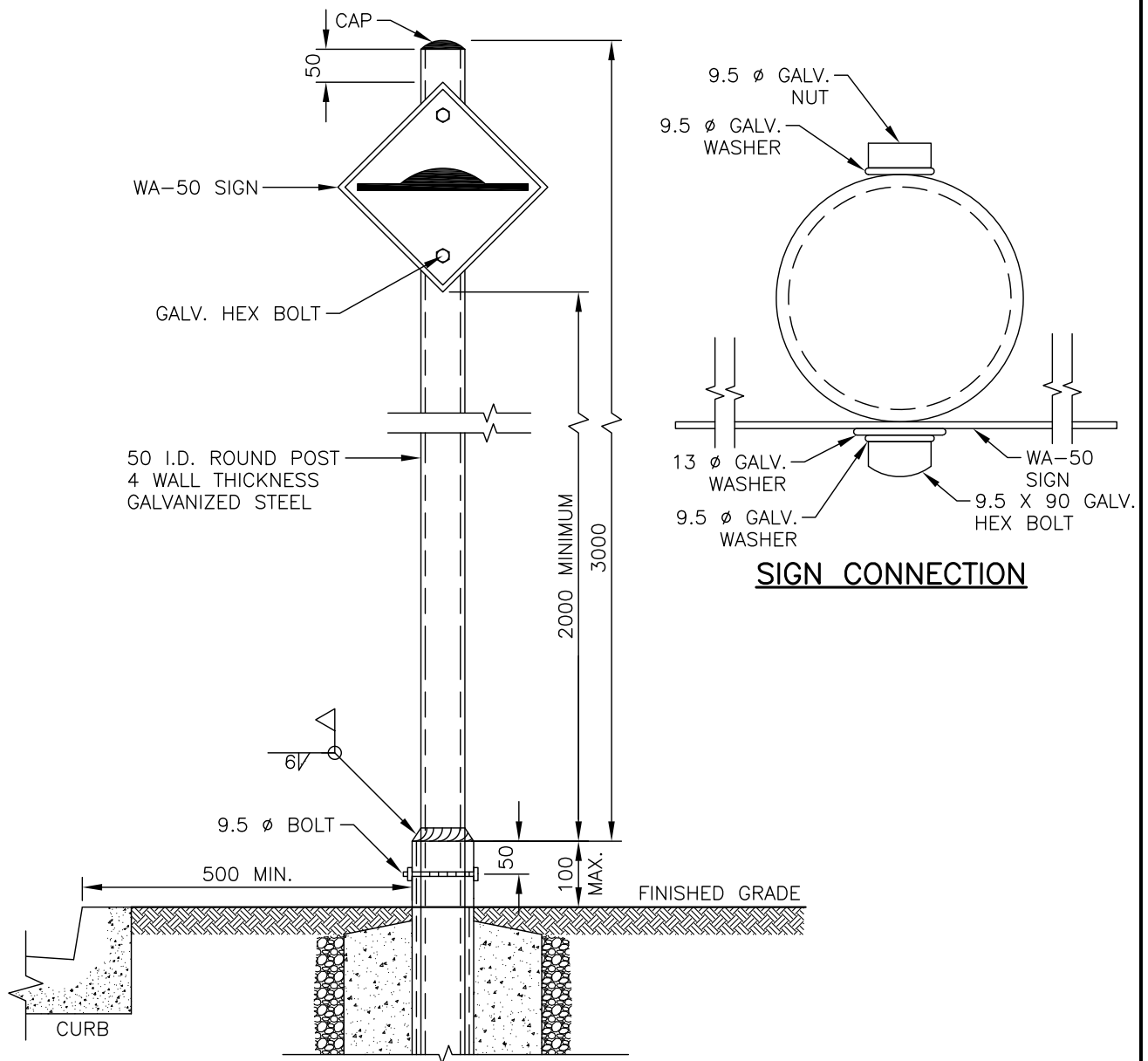

NOTES:

1. SIGN POST AND BASE AS PER STANDARD DETAIL HRM 38
2. HRM TO SUPPLY APPROPRIATE SIGNS.
3. WELD SHALL BE COMPLETED AROUND BASE AND POST.
4. CONTRACTOR TO USE 9.5 DIA. X 75MM LAG SCREW, COMPLETE WITH 13 DIA. GALV. AND 9.5 DIA. GALV. WASHERS WHEN INSTALLING SIGN TO UTILITY POLE.
5. ALL DIMENSIONS ARE IN MILLIMETRES.

HALIFAX

STANDARD DETAIL

**URBAN TRAFFIC SIGN
INSTALLATION**

| | | |
|---------------|-----------|----------------------------|
| DATE: 2024 | REFERENCE | APPROVED |
| SCALE: NTS | | FIG No.: HRM 129 |

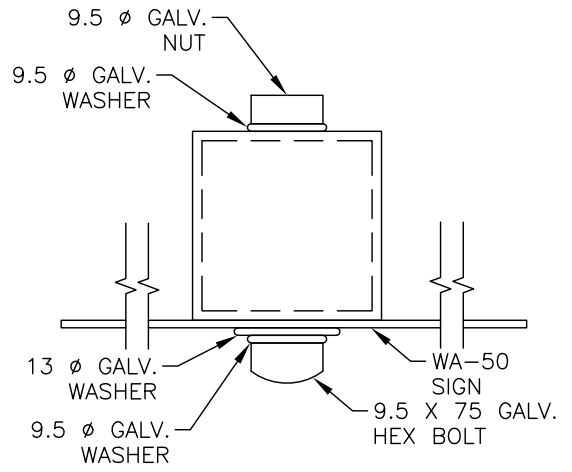
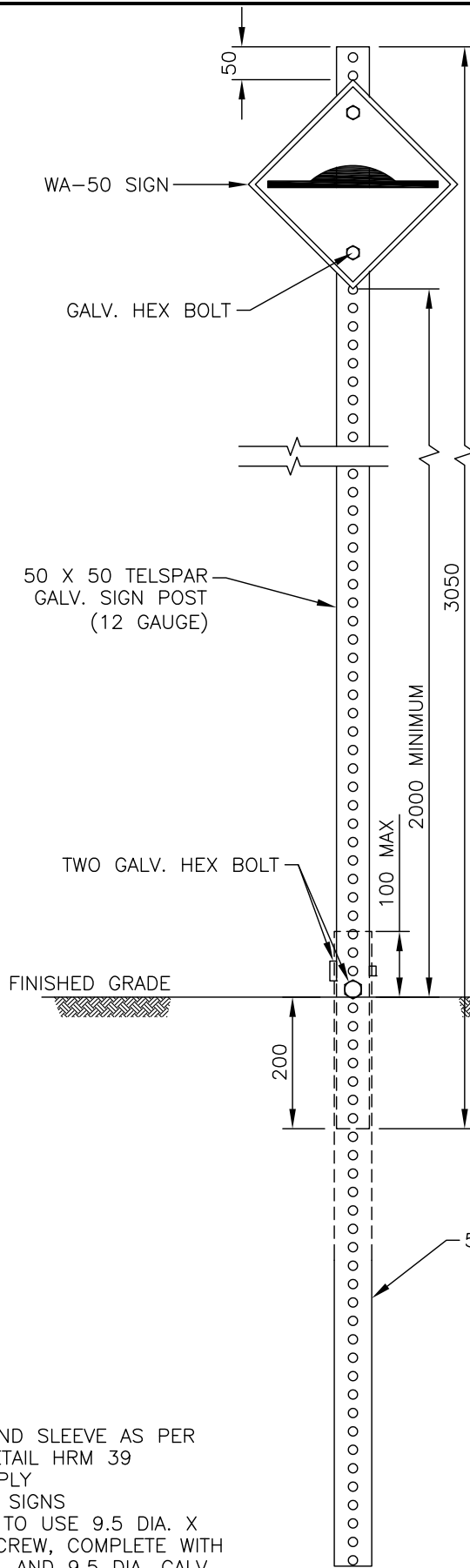

SIGN CONNECTION

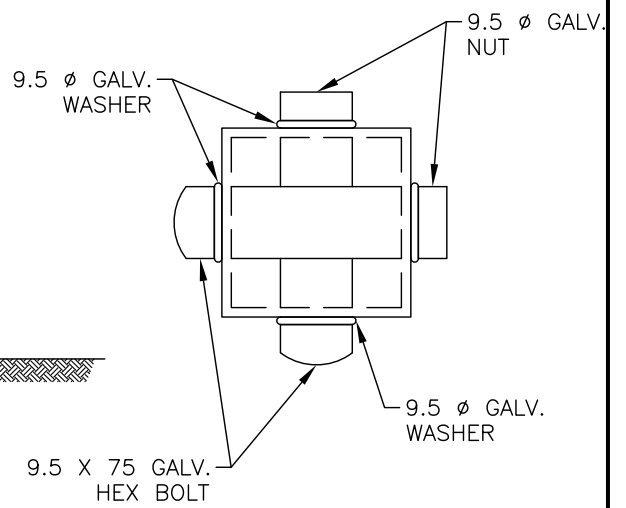

TWO HEX BOLT LOCK

NOTES:

1. SIGN POST AND SLEEVE AS PER STANDARD DETAIL HRM 39
2. HRM TO SUPPLY APPROPRIATE SIGNS
3. CONTRACTOR TO USE 9.5 DIA. X 75MM LAG SCREW, COMPLETE WITH 13 DIA. GALV. AND 9.5 DIA. GALV. WASHERS WHEN INSTALLING SIGN TO UTILITY POLE.
4. ALL DIMENSIONS ARE IN MILLIMETRES

HALIFAX

STANDARD DETAIL

**RURAL TRAFFIC
SIGN INSTALLATION**

| | | |
|--------|-----------|----------|
| DATE: | REFERENCE | APPROVED |
| 2024 | | |
| SCALE: | | FIG No.: |
| NTS | | HRM 130 |

NOTES:

1. NATURAL CAST IRON ATTENTION TWSI (TACTILE WALKING SURFACE INDICATOR) PLATES. TO CSA B651, AND AS INDICATED IN THE PROJECT DOCUMENTS.
2. NO GAP BETWEEN ADJACENT PLATES.
3. MAXIMUM DISTANCE FROM CURB TAPER TO BE 100mm.
4. PLATES SHALL BE PLACED WITH THE TOP OF THE BASE PLATE (BOTTOM OF DOMES) LEVEL WITH CONCRETE SURFACE.
5. ALL PLATES TO BE 610mm LONG.
6. TO BE READ IN CONJUNCTION WITH HRM DETAIL 49 PEDESTRIAN RAMP ALIGNMENT.
7. SIZE AND SHAPE OF PLATES TO MANUFACTURER'S SPECIFICATION.
8. CONCRETE THICKNESS AT PEDESTRIAN RAMPS TO BE 150 mm.
9. DIMENSIONS ARE IN MILLIMETRES UNLESS OTHERWISE NOTED.

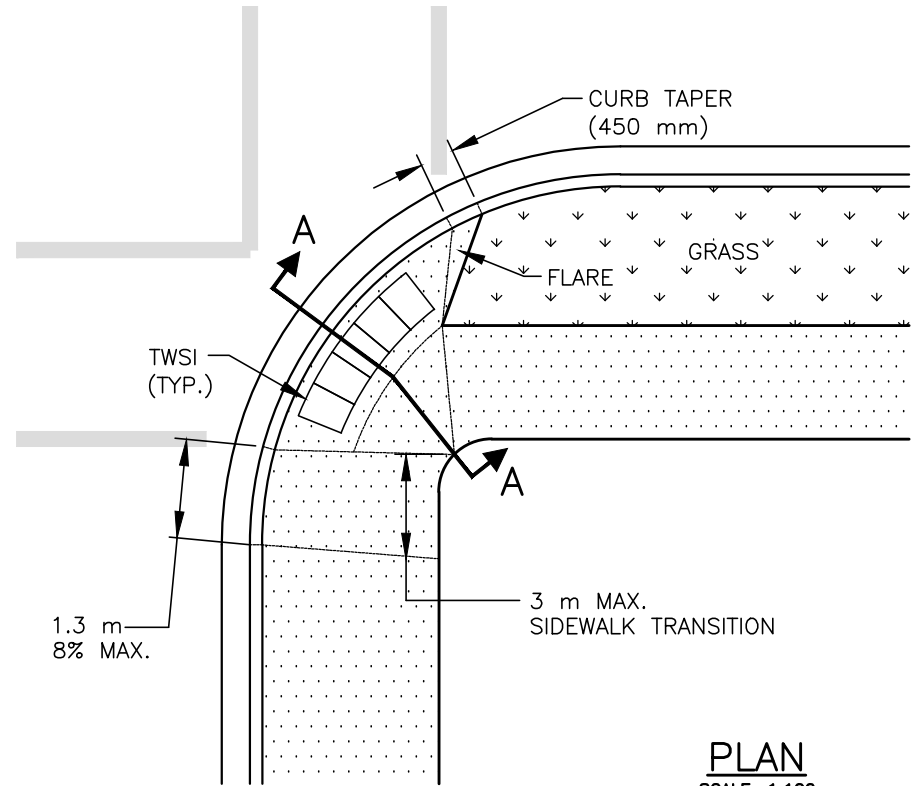

PLAN
SCALE: 1:100

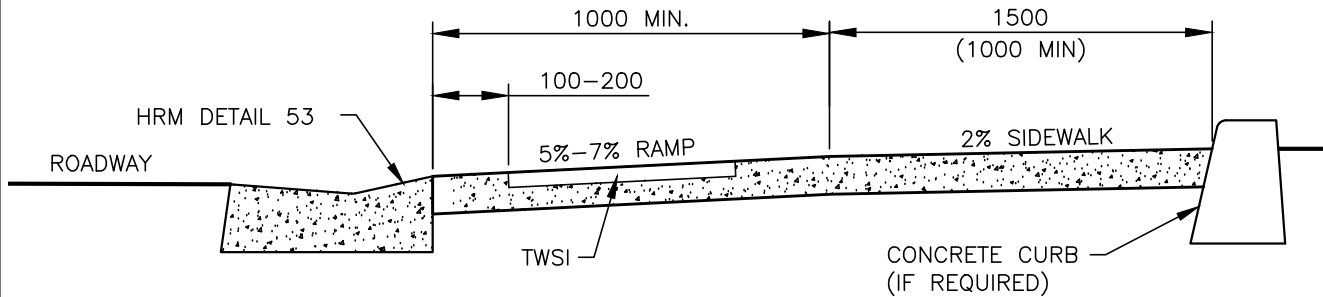

CROSS SECTION A-A

SCALE 1:20

HALIFAX

STANDARD DETAIL

**TACTILE WALKING SURFACE
INDICATOR RAMP PLACEMENT**

| | | |
|--------------------|-----------|---------------------|
| DATE: 2023 | REFERENCE | APPROVED |
| SCALE: AS NOTED | | FIG No.: HRM 131 |

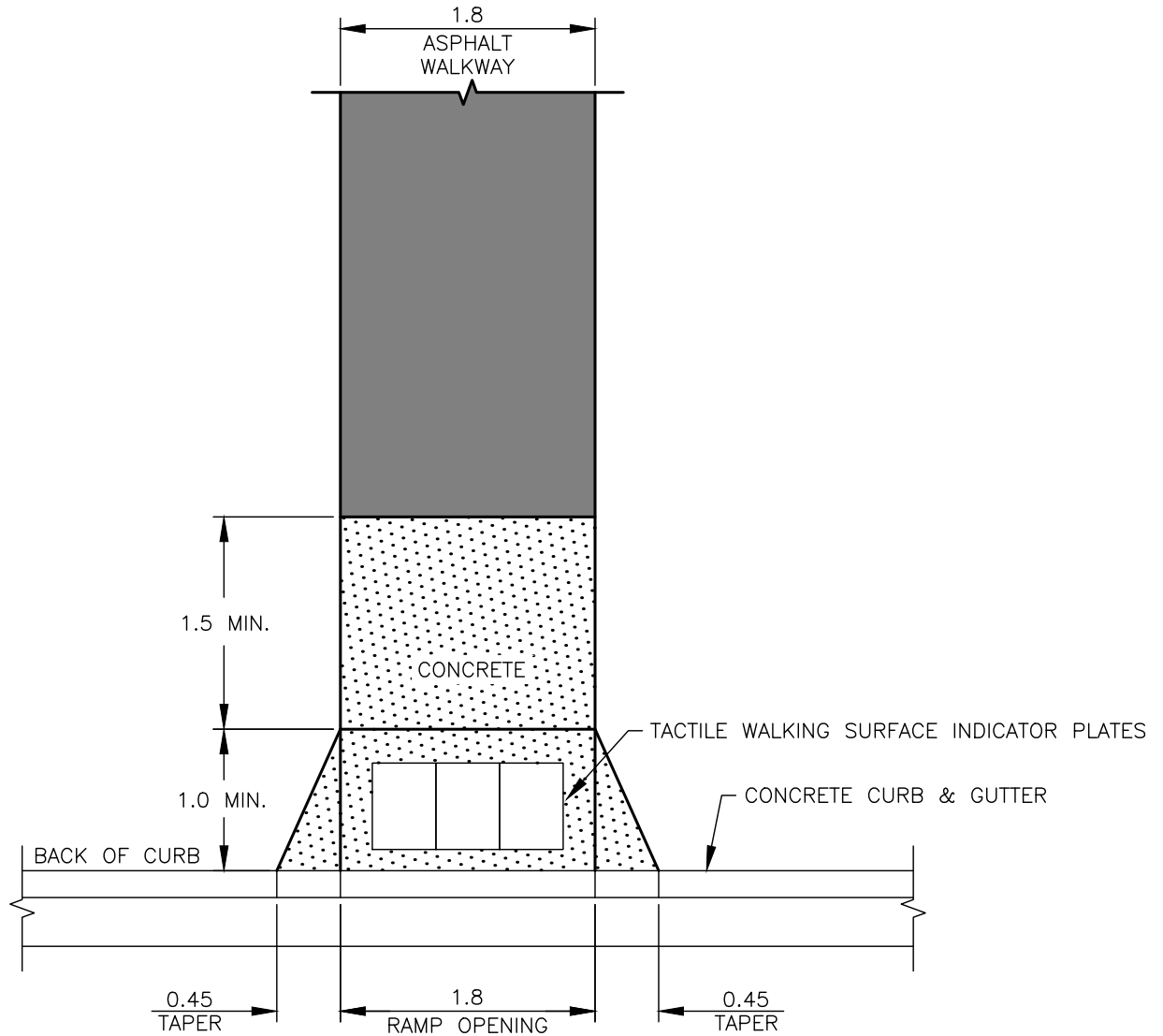

NOTES:

1. CONCRETE PEDESTRIAN RAMP TO HRM DETAIL 49.
2. CONCRETE CURB & GUTTER TO HRM DETAIL 53.
3. TACTILE WALKING SURFACE INDICATOR PLATES TO HRM DETAIL 131.
4. ASPHALT WALKWAY TO HRM DETAIL 40.

HALIFAX

STANDARD DETAIL

WALKWAY WITH
PEDESTRIAN RAMP

| | | | |
|--------|------|-----------|---------------------|
| DATE: | 2021 | REFERENCE | APPROVED |
| SCALE: | 1:50 | | FIG No.: HRM 132 |

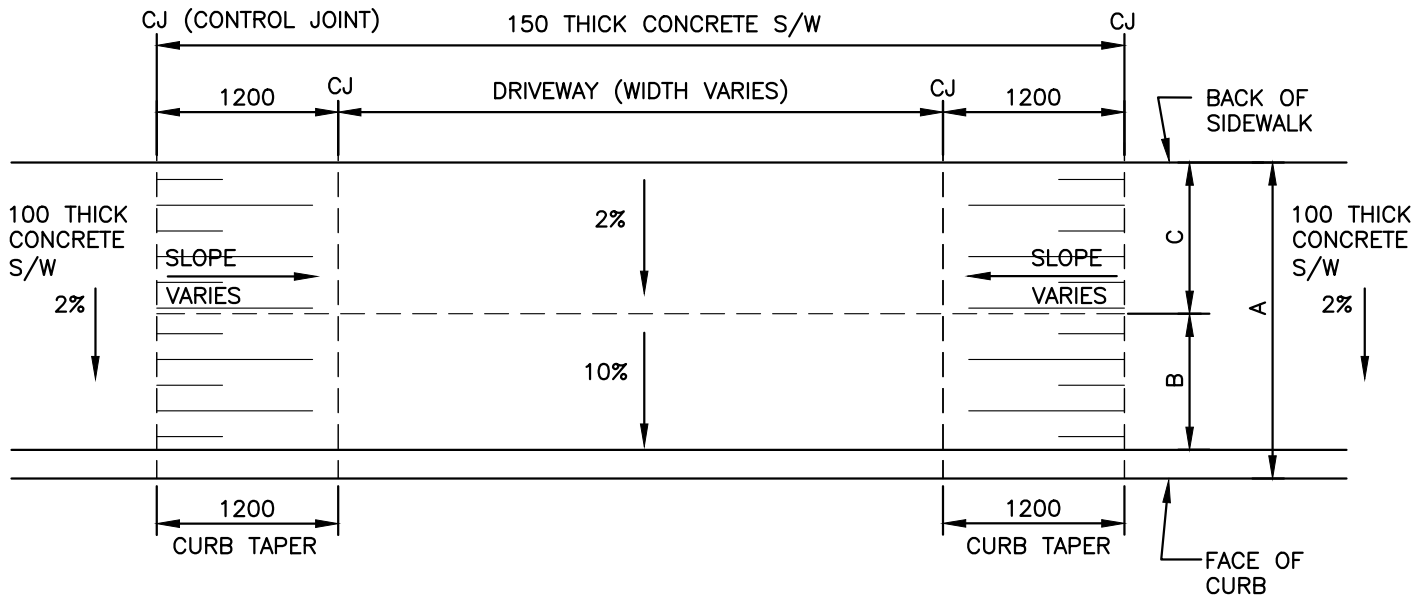

| A | B | C | D |
|------|------|------|----|
| 1800 | 600 | 1000 | 57 |
| 1900 | 700 | 1000 | 49 |
| 2000 | 800 | 1000 | 41 |
| 2100 | 900 | 1000 | 33 |
| 2200 | 900 | 1100 | 33 |
| 2300 | 900 | 1200 | 33 |
| 2400 | 900 | 1300 | 33 |
| 2500 | 900 | 1400 | 33 |
| 2600 | 900 | 1500 | 33 |
| 2700 | 1000 | 1500 | 24 |
| 2800 | 1100 | 1500 | 16 |
| 2900 | 1200 | 1500 | 8 |
| 3000 | 1300 | 1500 | 0 |

NOTES:

1. WHEN ADJACENT DRIVEWAYS ARE LESS THAN 2.4 METERS APART, DO NOT TAPER CURB AND SIDEWALK BETWEEN DRIVEWAYS.
2. AREA BEHIND DROPPED S/W MAY REQUIRE BUILD UP WITH PAVEMENT OR CURB TO PREVENT ENTRY OF STORM WATER DURING MAJOR STORM.

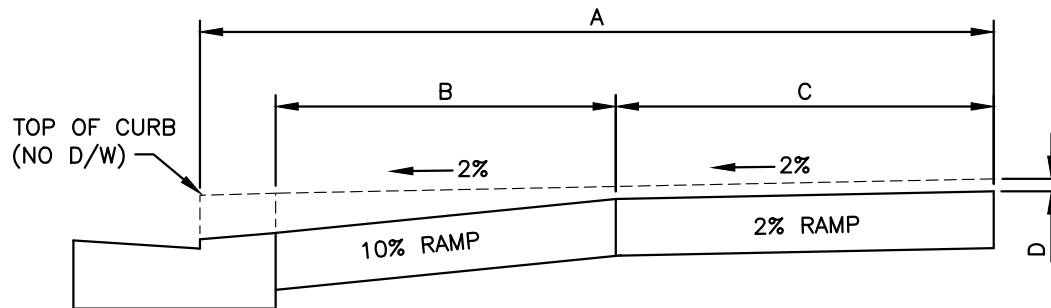

HALIFAX

STANDARD DETAIL
CONCRETE SIDEWALK
ADJACENT CURB

| | | | |
|--------|----------|-----------|----------------------------|
| DATE: | 2021 | REFERENCE | APPROVED |
| SCALE: | AS NOTED | | FIG No.: HRM 133 |

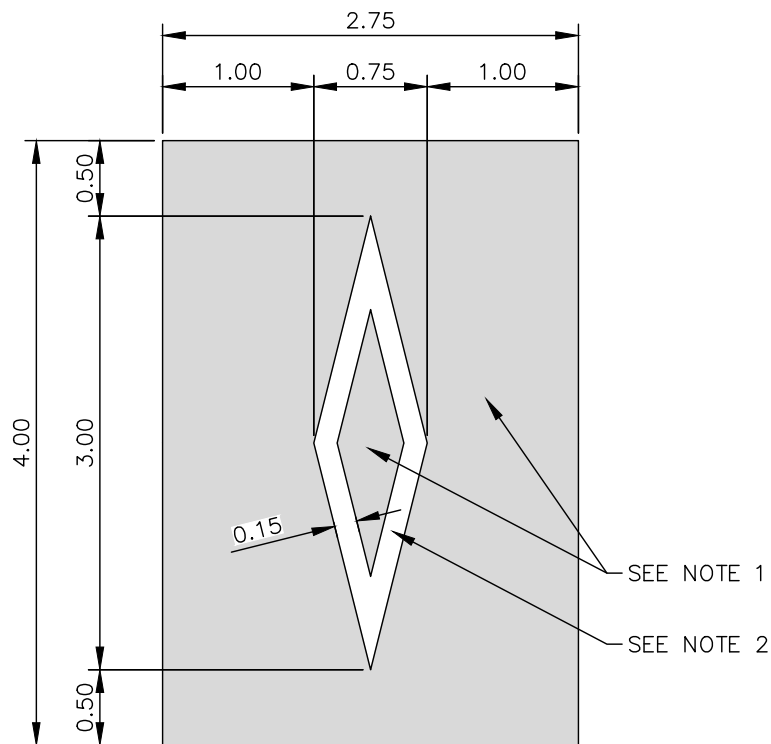

NOTE:

1. PERMANENT PAVEMENT MARKING FOR IN-LAY SHALL BE RED.
2. PERMANENT PAVEMENT MARKING FOR RESERVED LANE SYMBOL SHALL BE WHITE.
3. DIMENSIONS ARE IN METRES.

| | | |
|---------------------------------|------|----------------------------|
| HALIFAX | | |
| STANDARD DETAIL | | |
| RED IN-LAY RESERVED LANE | | |
| DATE: | 2021 | REFERENCE |
| SCALE: | 1:50 | APPROVED |
| | | FIG. NO. HRM 134 |

NOTES:

1. POSTS 60 mm O.D. HOT DIPPED GALVANIZED COLD ROLLED STEEL (ASTM A53 GRADE A, SCHEDULE 40), ZINC-COATED AT MINIMUM 550 G/SM.
2. UNLESS OTHERWISE APPROVED BY ENGINEER, DRILL POST HOLES WITH 125 mm MAXIMUM DIAMETER BIT. STABILIZE GROUND AROUND POSTS WITH CEMENT GROUT AND MECHANICAL COMPACTOR.
3. THERE SHALL BE NO EXPOSED (NON-GALVANIZED) STEEL, EXCEPT THE TOP OF THE POSTS (PRIOR TO PLACEMENT OF CAPS).
4. POST SPACING OF 2.4 m EXCEPT LESS ON TIGHT TURNS TO MAINTAIN TRAIL WIDTH.
5. GALVANIZED STEEL CAPS TO BE SET SECURELY OVER TOP OF POSTS (WELDING NOT PERMITTED).
6. RAILS 95-115 mm DIAMETER SMOOTH UNTREATED HEMLOCK WOOD (NO CHECKS, SPLITS OR WIND SHAKES). OUTSIDE EDGES OF ABUTTING ENDS OF RAILS SHALL BE FLUSH (WITHIN 5 mm). PROVIDE FLAT SURFACE FOR FASTENERS 20 mm FROM BACK OF RAILS WHICH CAN BE THE FULL LENGTH OF THE RAILS.
7. ENDS OF RAILS SHALL LINE UP WITH CENTRE OF POSTS EXCEPT AT END POSTS WHERE THE RAILS SHALL EXTEND 100 mm PAST THE CENTRE OF POSTS.
8. FENCE BRACKETS TO BE GALVANIZED STEEL AND DESIGNED TO ATTACH WOODEN FENCE RAILS WITH A FLAT FASTENING SURFACE TO 60 mm O.D. FENCE POSTS. BRACKETS TO HAVE A BASE AND STRAP. BRACKETS TO HAVE 8 mm LAG SCREWS (38 mm LONG) FOR FASTENING BRACKET BASE TO WOOD RAIL, AND 8 mm CARRIAGE BOLTS WITH NUTS FOR FASTENING BRACKET BASE AND STRAP AROUND POST. BASE TO BE BENDABLE TO ALLOW FOR VARIED HORIZONTAL ANGLES BETWEEN SUCCESSIVE RAILS.
9. PRE-DRILL WOODEN RAILS FOR INSTALLATION OF BRACKETS.
10. BEND FLANGES OF BRACKETS TO ANGLE REQUIRED WHEN FENCE IS ON A HORIZONTAL CURVE.
11. MATERIALS AND CONSTRUCTION SHALL BE IN ACCORDANCE WITH THE LATEST REVISIONS OF THE NOVA SCOTIA BUILDING CODE REGULATIONS AND THE NATIONAL BUILDING CODE OF CANADA.
12. DIMENSIONS ARE IN MILLIMETRES.

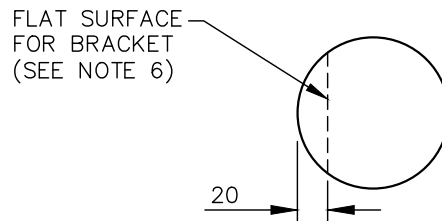
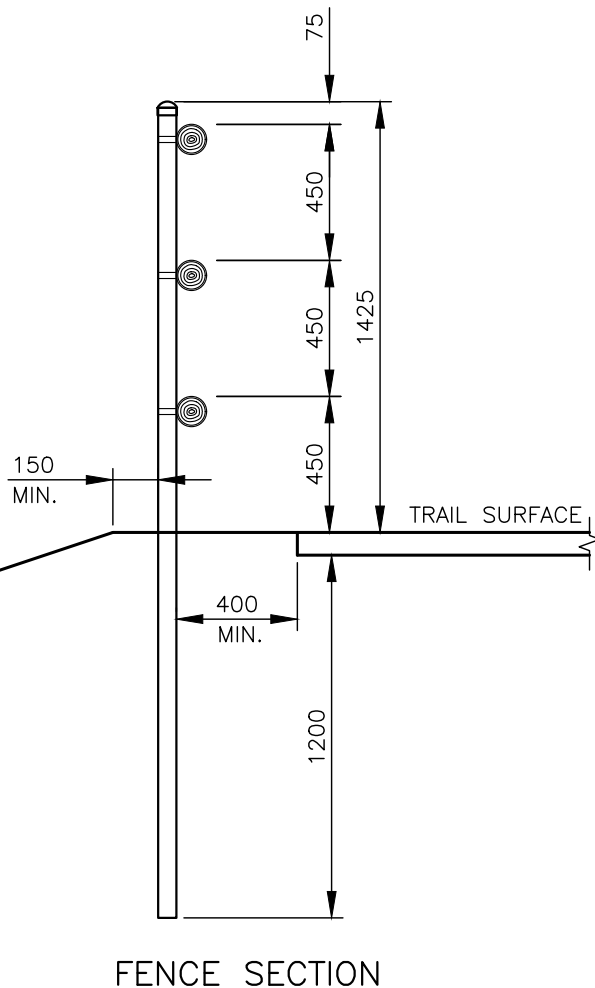

WOODEN RAIL SECTION AT POST

| | | |
|--|------|----------------------------|
| HALIFAX | | |
| STANDARD DETAIL | | |
| FENCE DETAIL (ROUND WOODEN RAILS & STEEL POSTS) | | |
| DATE: | 2021 | REFERENCE |
| SCALE: | NTS | APPROVED |
| | | FIG. NO. HRM 135 |

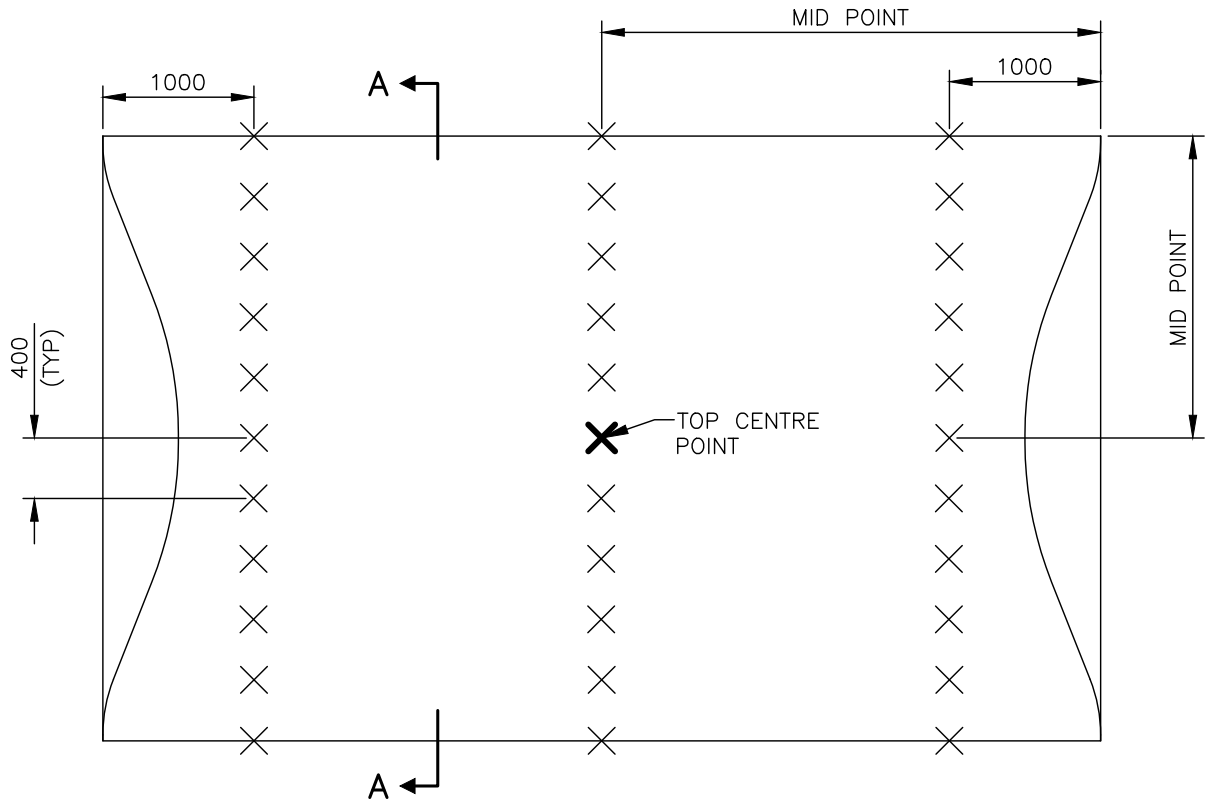

SPEED HUMP

SCALE: 1:50

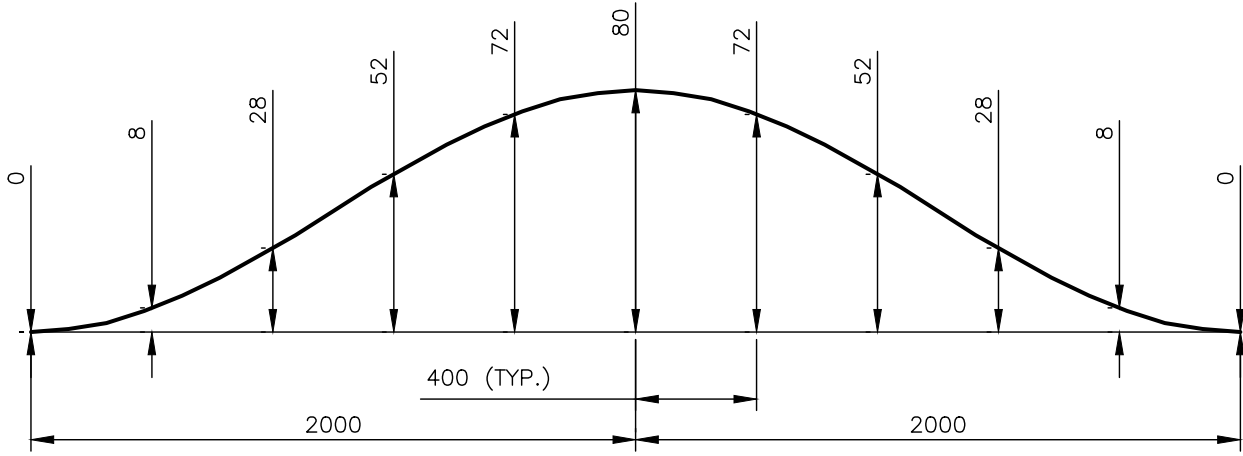

SECTION A-A

SCALE: Horz. 1:25
Vert. 1:2.5

NOTES:

1. 33 SURVEY SHOTS ELEVATION REQUIRED.
2. COORDINATES REQUIRED AT THE TOP CENTRE OF THE SPEED HUMP.
3. DIMENSIONS ARE IN MILLIMETRES.

| |
|-------------------------------|
| TOP CENTRE POINT COORDINATES: |
| NORTHING: |
| EASTING: |

HALIFAX

STANDARD DETAIL

**SPEED HUMP
SURVEY VERIFICATION**

| | | |
|-----------------|-----------|------------------|
| DATE: 2021 | REFERENCE | APPROVED |
| SCALE: AS NOTED | | FIG No.: HRM 136 |

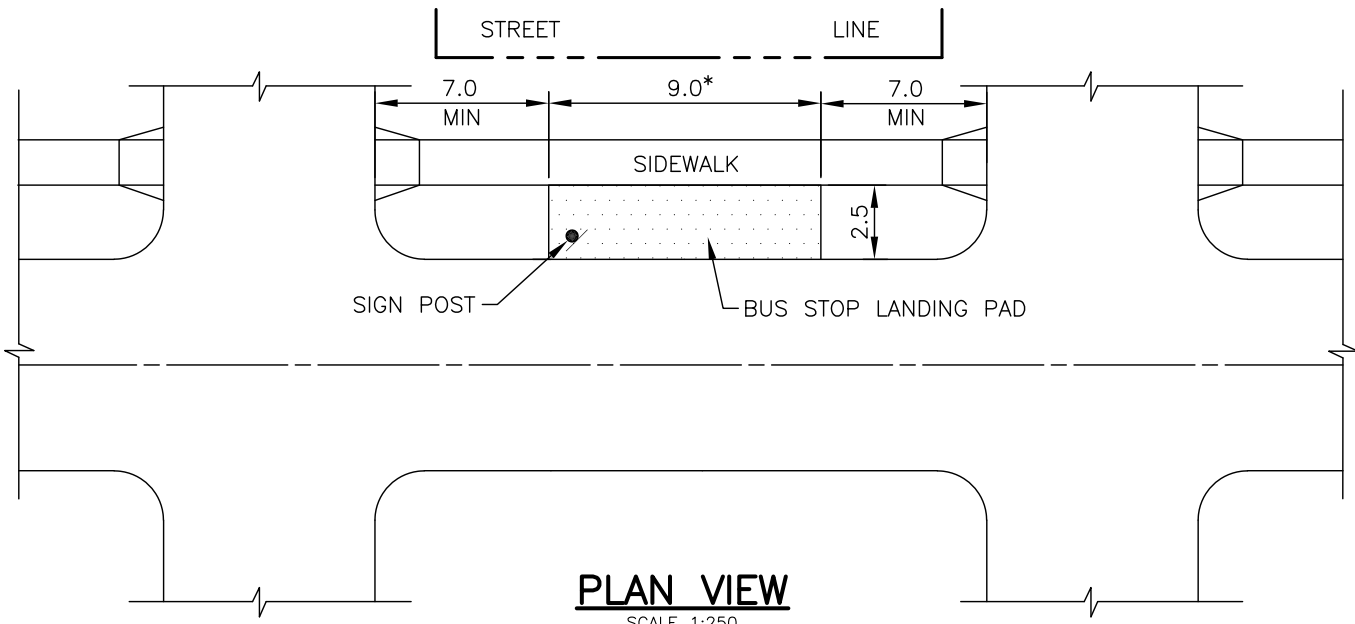

PLAN VIEW
SCALE 1:250

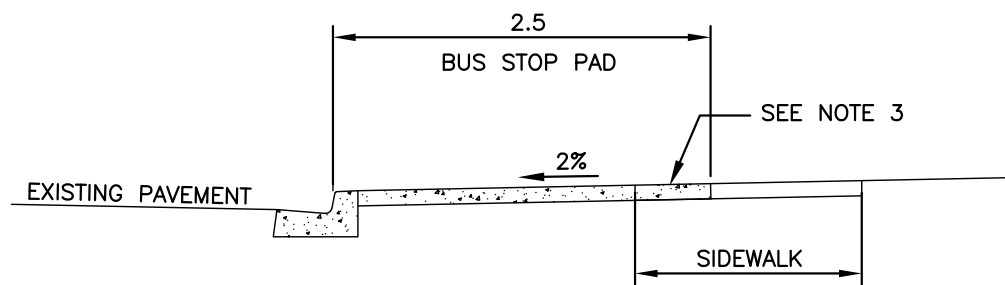

CROSS SECTION
SCALE 1:50

NOTES:

- * 1. FOR LOW VOLUME BUS ROUTES ON LOCAL STREETS
-DECREASE PAD LENGTH TO 4.0 m.
- * 2. FOR ARTICULATED BUS ROUTES
-INCREASE PAD LENGTH TO 14.5 m.
- 3. THE 2.5 m WIDE BUS STOP LANDING PAD MAY INCLUDE A PORTION OF THE SIDEWALK AS REQUIRED.

| | | |
|---|-----------|----------------------------|
| HALIFAX | | |
| STANDARD DETAIL | | |
| CONCRETE BUS STOP LANDING PAD (WITH SIDEWALK) | | |
| DATE: 2024 | REFERENCE | APPROVED |
| SCALE: AS NOTED | | FIG No.: HRM 138 |

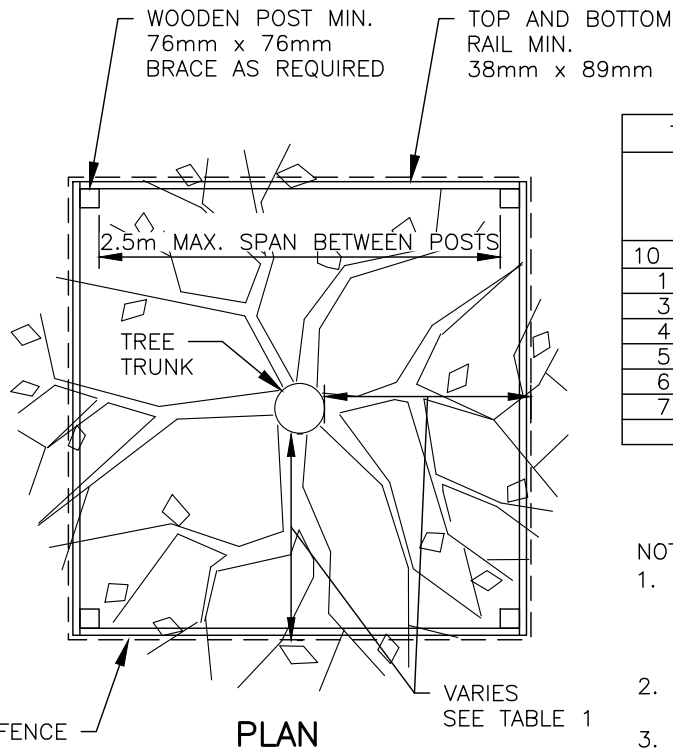

PLAN

TABLE 1

TREE PROTECTION ZONE CALCULATION TABLE

| TRUNK DIAMETER (DBH) | MINIMUM PROTECTION DISTANCE REQUIRED (MEASURE FROM THE OUTSIDE EDGE OF TREE TRUNK) |
|----------------------|--|
| 10 CM & UNDER | 1.2 METERS |
| 11 – 30 CM | 2.0 METERS |
| 31 – 40 CM | 3.4 METERS |
| 41 – 50 CM | 4.6 METERS |
| 51 – 60 CM | 6.0 METERS |
| 61 – 70 CM | 7.0 METERS |
| 71 – 80 CM | 8.0 METERS |
| >80 CM | 9.0 METERS |

NOTES:

1. WOOD POST: (MIN. 76mm WIDTH) INSTALLED TO A DEPTH OF 500mm. TOP AND BOTTOM RAIL: (MIN. 38 x 89mm CONSTRUCTION, MAX. SPAN 2.5m), CROSS BRACING AS REQUIRED.
2. NO GROUND DISTURBANCE WITHIN 1.2 METER OF THE TREE TRUNK (I.E. POST INSTALLATION)
3. POSTS SET BACK FROM SIDEWALK AND CURB: MIN 300mm
4. FENCE MATERIAL: MINIMUM ORANGE BARRIER FENCE OR METAL CHAIN LINK FENCE
5. ATTACH A SIGN ON TWO SIDES OF THE TREE "PROTECTION ZONE DO NOT REMOVE FENCE DURING CONSTRUCTION"

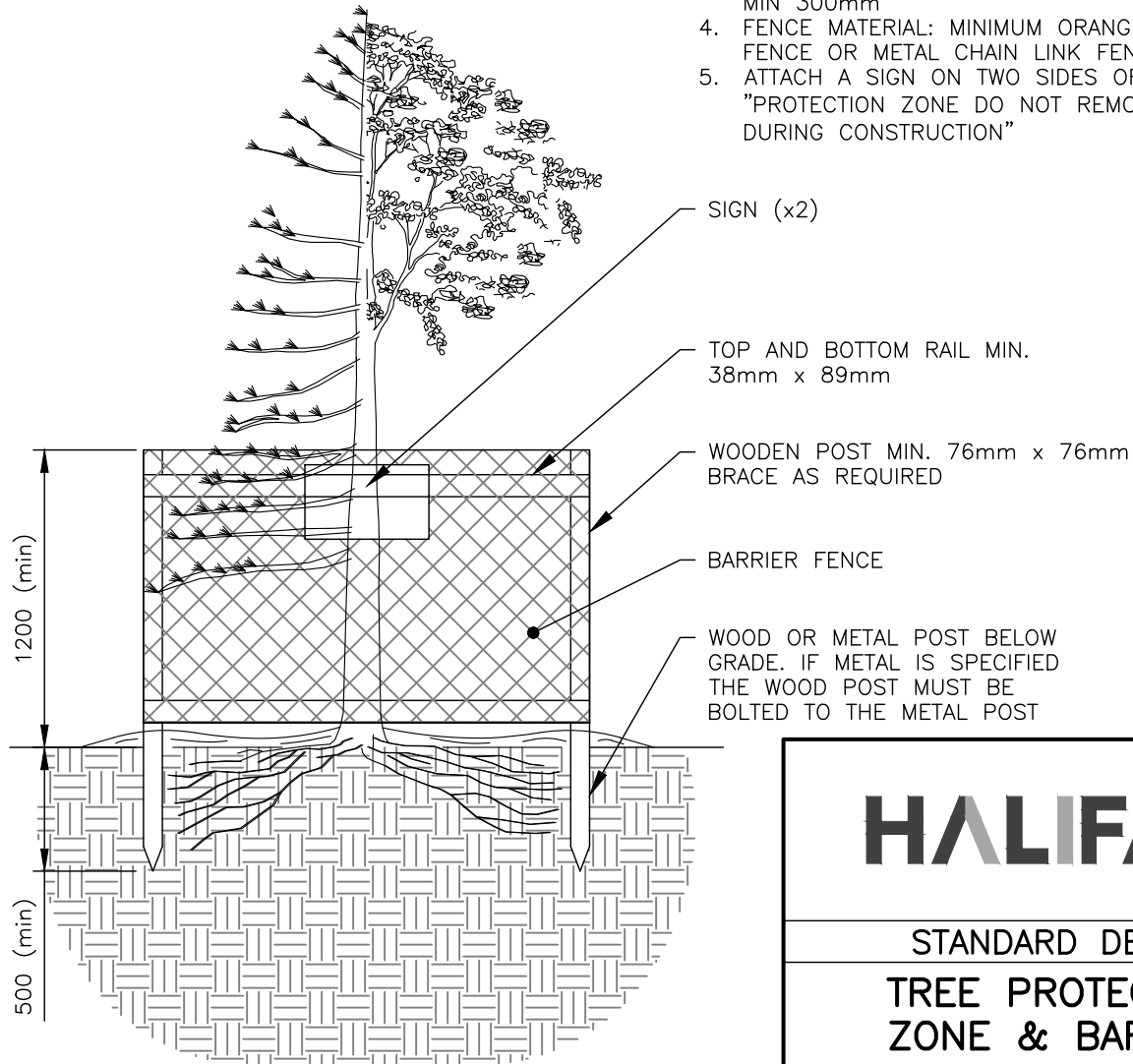

PROFILE

HALIFAX

STANDARD DETAIL

TREE PROTECTION ZONE & BARRIER

| | | |
|--------|-----------|----------|
| DATE: | REFERENCE | APPROVED |
| 2021 | | |
| SCALE: | | FIG No.: |
| NTS | | HRM 140 |

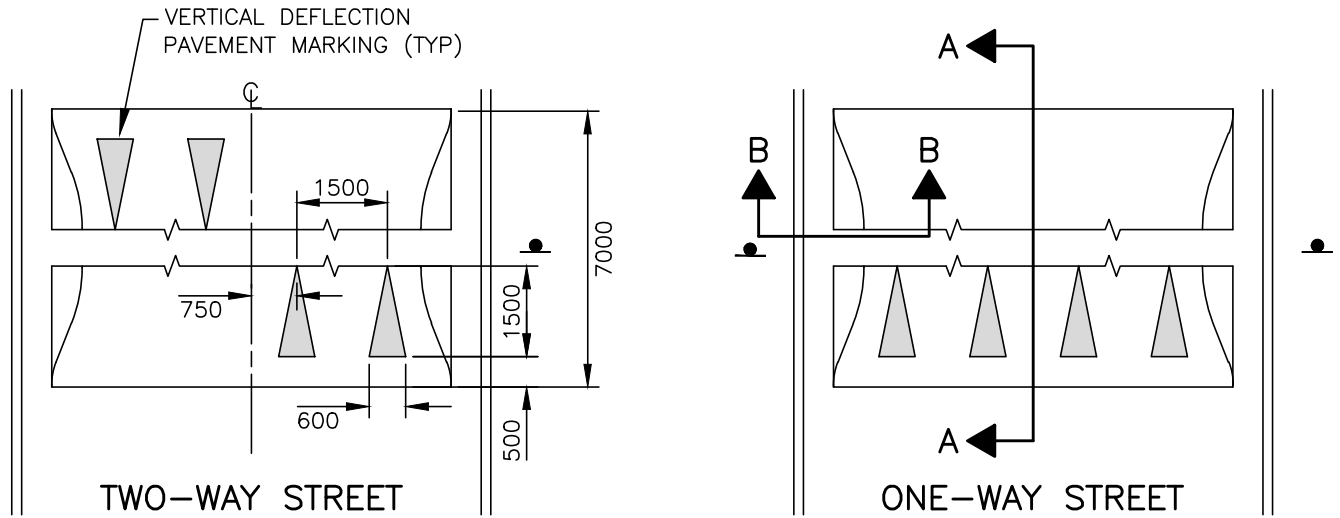

TWO-WAY STREET

ONE-WAY STREET

SPEED TABLE
SCALE: 1:125

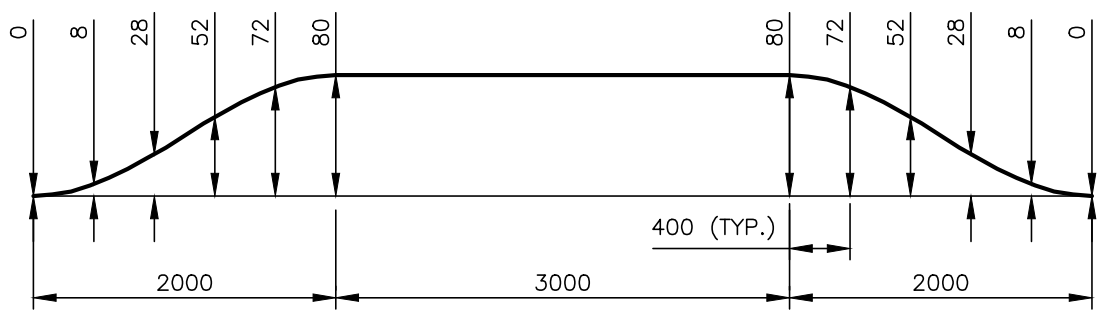

SECTION A-A
SCALE: Horz. 1:50 , Vert. 1:5

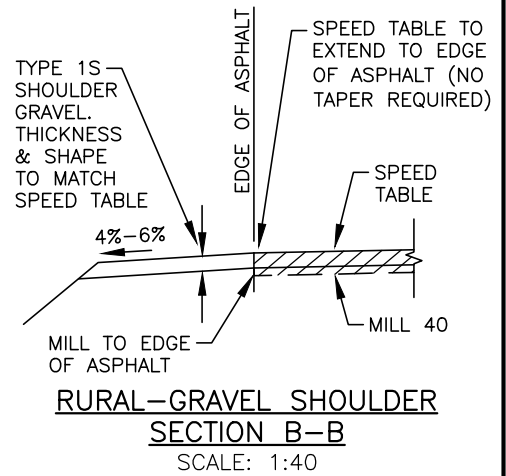
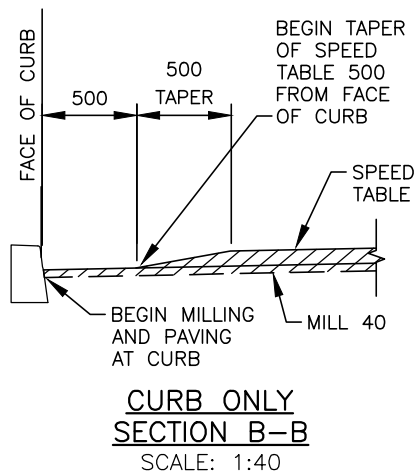
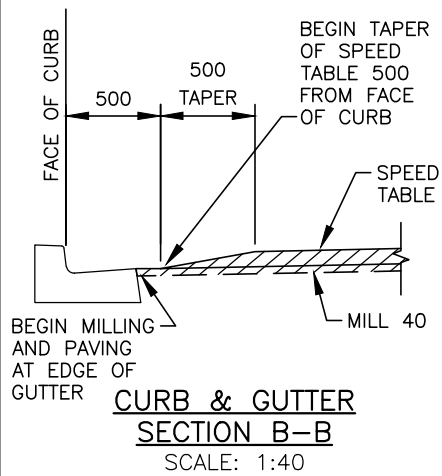

NOTES:

1. TOLERANCE FOR CONSTRUCTION IS +/- 10mm RELATIVE TO THE CURVE.
2. THE EXISTING ASPHALT SURFACE TO BE MILLED TO A DEPTH OF 40mm WHEN RETROFITTING.
3. SPEED TABLES TO BE CONSTRUCTED USING TYPE D-HF ASPHALT (UNLESS OTHERWISE APPROVED BY HRM).
4. WHERE SPECIFIED, EXISTING UTILITY POLE OR EXISTING SIGN POSTS MAY BE USED FOR SIGNAGE.
5. DIMENSIONS ARE IN MILLIMETRES.

HALIFAX

STANDARD DETAIL

SPEED TABLE

| | | |
|-----------------|-----------|------------------|
| DATE: 2023 | REFERENCE | APPROVED |
| SCALE: AS NOTED | | FIG No.: HRM 143 |

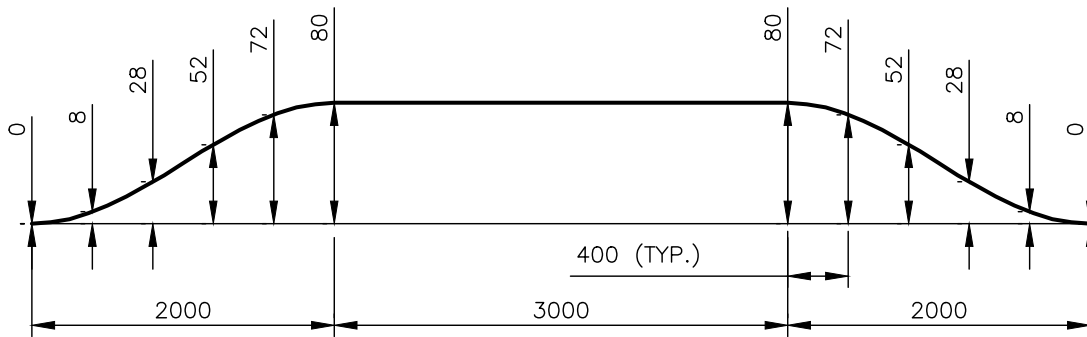
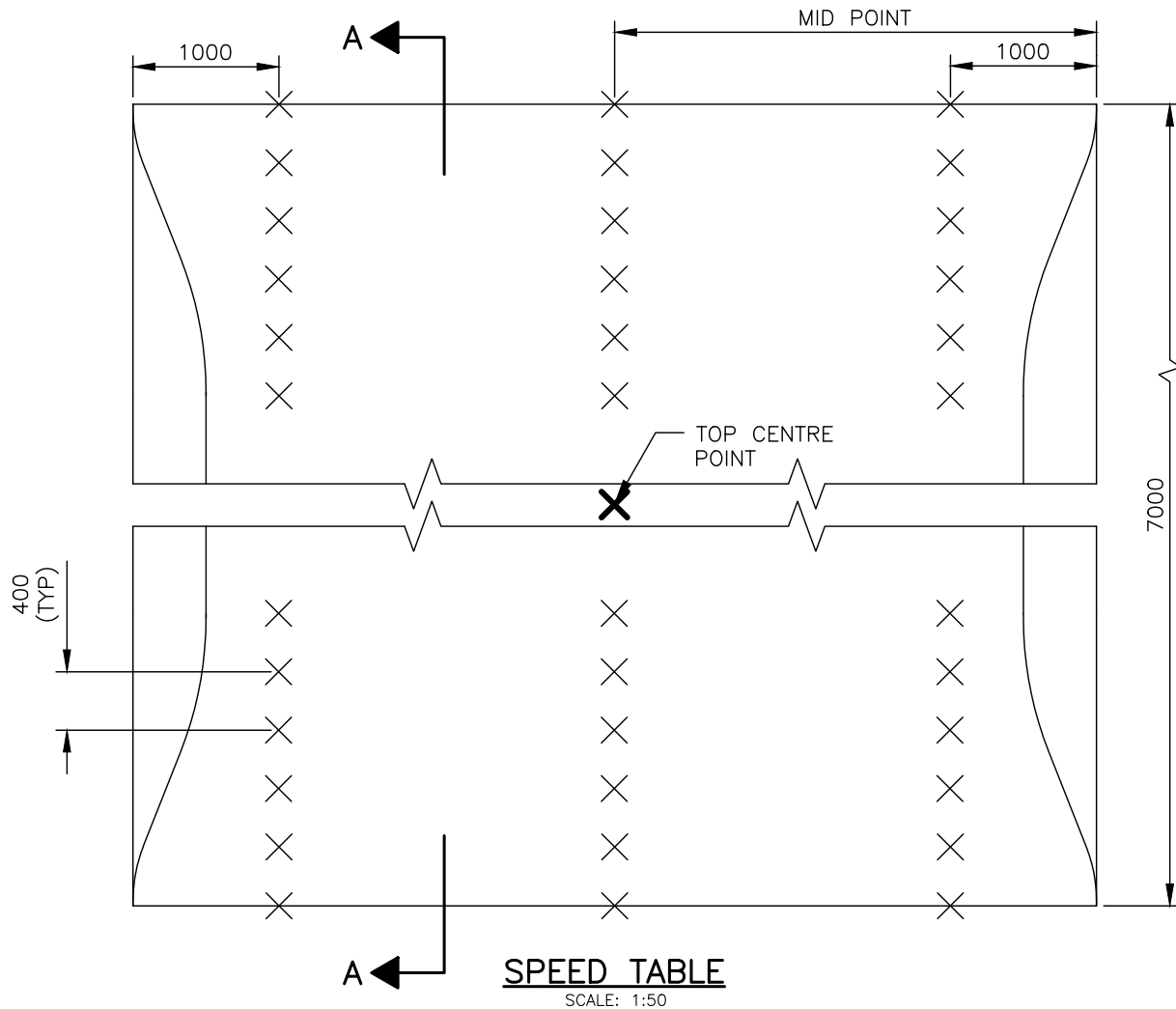

SECTION A-A

SCALE: Horz. 1:50
Vert. 1:5

NOTES:

1. 36 SURVEY SHOTS ELEVATION REQUIRED.
2. COORDINATES REQUIRED AT THE TOP CENTRE OF THE SPEED TABLE.
3. DIMENSIONS ARE IN MILLIMETRES.

| | |
|--------------------------------------|----------------|
| <u>TOP CENTRE POINT COORDINATES:</u> | |
| NORTHING: | EASTING: |

HALIFAX

STANDARD DETAIL

SPEED TABLE
SURVEY VERIFICATION

| | | |
|-----------------|-----------|----------------------------|
| DATE: 2021 | REFERENCE | APPROVED |
| SCALE: AS NOTED | | FIG No.: HRM 144 |

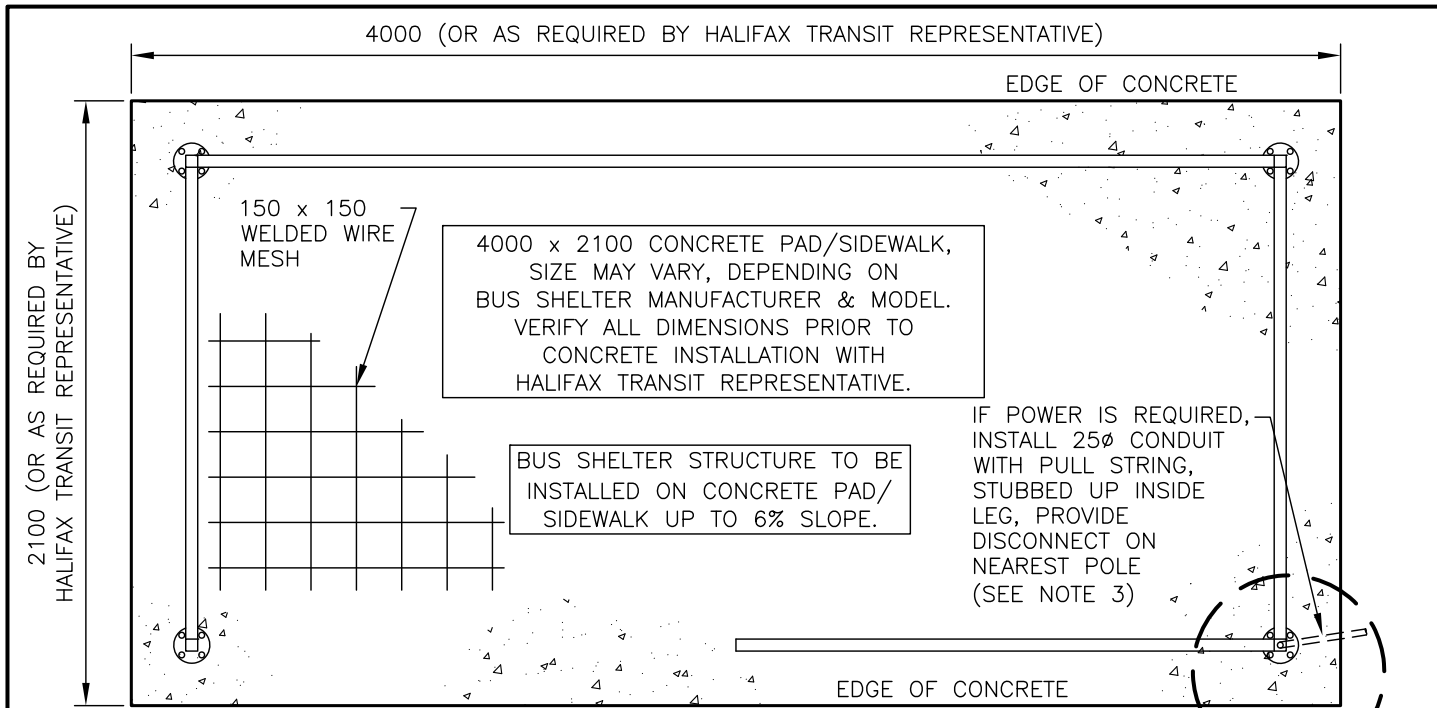

PLAN VIEW

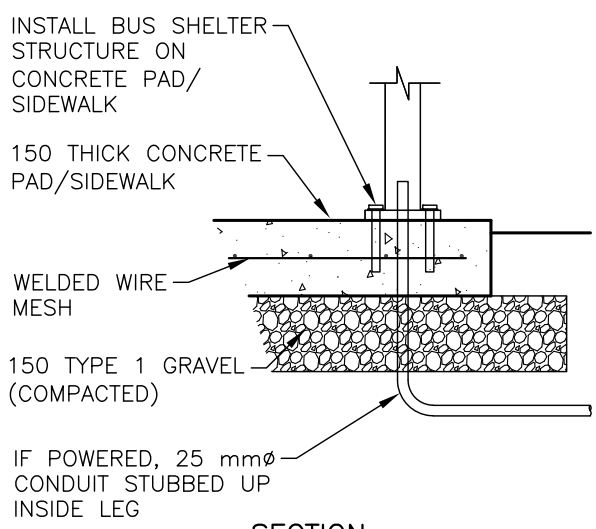

SECTION

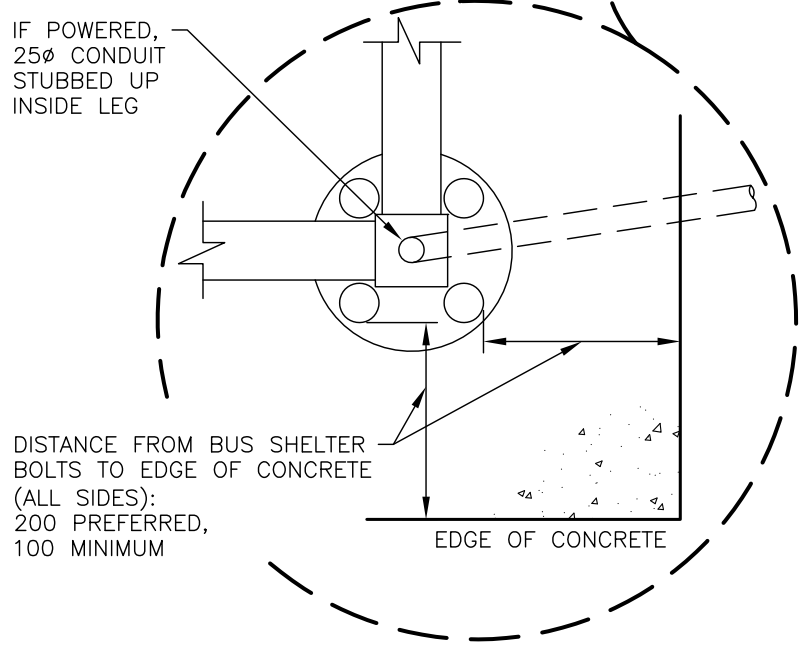

NOTES:

1. BEFORE ORDERING MATERIALS AND PRIOR TO CONSTRUCTION, VERIFY ALL EQUIPMENT AND SHELTER PLACEMENT/REQUIREMENTS WITH HALIFAX TRANSIT REPRESENTATIVE.
2. FOR INSTALLATION OF BUS SHELTER STRUCTURE FOLLOW MANUFACTURER'S INSTALLATION INSTRUCTIONS.
3. POWER CAN BE RUN INTO ANY OF THE SHELTER LEGS - CONTACT TRANSIT TO CONFIRM.
4. DIMENSIONS ARE IN MILLIMETRES.

| | | |
|--|-----------|----------------|
| <h1>HALIFAX</h1> | | |
| STANDARD DETAIL | | |
| BUS STOP SHELTER ON CONCRETE SIDEWALK | | |
| DATE: | REFERENCE | APPROVED |
| 2024 | | |
| SCALE: | | FIG No.: |
| NTS | | HRM 153 |

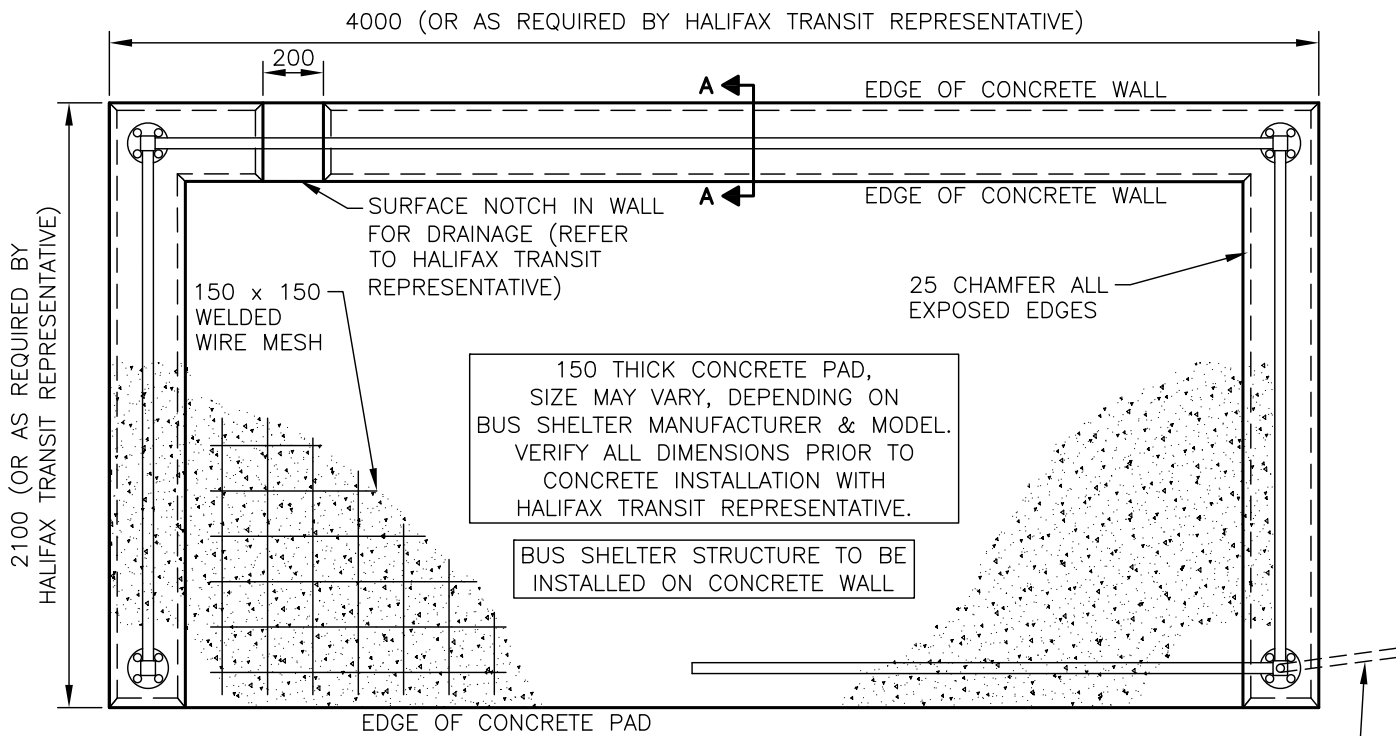

NOTE: ENSURE WALL IS CENTERED ON SHELTER BRACKETS

PLAN VIEW

IF POWER IS REQUIRED, INSTALL 25Ø CONDUIT WITH PULL STRING, STUBBED UP INSIDE WALL THRU LEG, PROVIDE DISCONNECT ON NEAREST POLE (SEE NOTE 3)

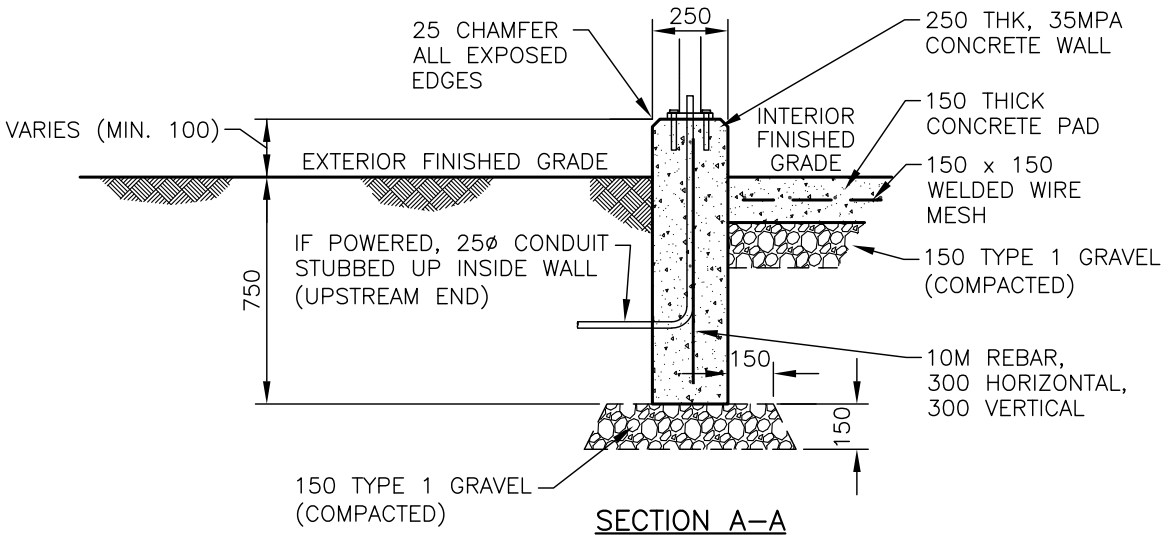

SECTION A-A

NOTES:

1. BEFORE ORDERING MATERIALS AND PRIOR TO CONSTRUCTION, VERIFY ALL EQUIPMENT AND SHELTER PLACEMENT/REQUIREMENTS WITH HALIFAX TRANSIT REPRESENTATIVE.
2. FOR INSTALLATION OF BUS SHELTER STRUCTURE FOLLOW MANUFACTURER'S INSTALLATION INSTRUCTIONS.
3. POWER CAN BE RUN INTO ANY OF THE SHELTER LEGS – CONTACT TRANSIT TO CONFIRM.
4. DIMENSIONS ARE IN MILLIMETRES.

HALIFAX

STANDARD DETAIL

BUS STOP SHELTER ON CONCRETE WALL

| | | | |
|--------|------|-----------|----------------------------|
| DATE: | 2024 | REFERENCE | APPROVED |
| SCALE: | NTS | | FIG No.: HRM 155 |

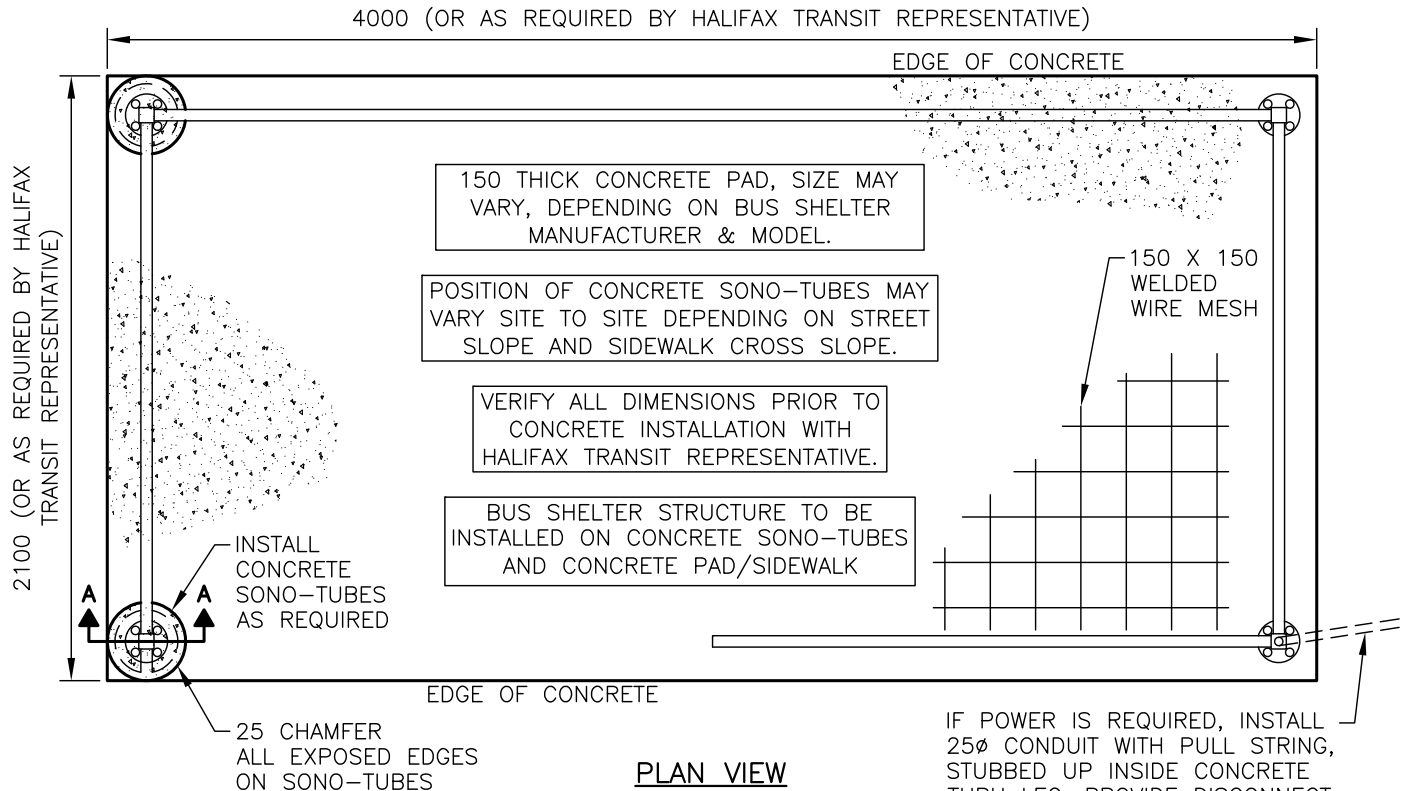

NOTE: ENSURE SONO-TUBE IS CENTERED ON SHELTER BRACKETS

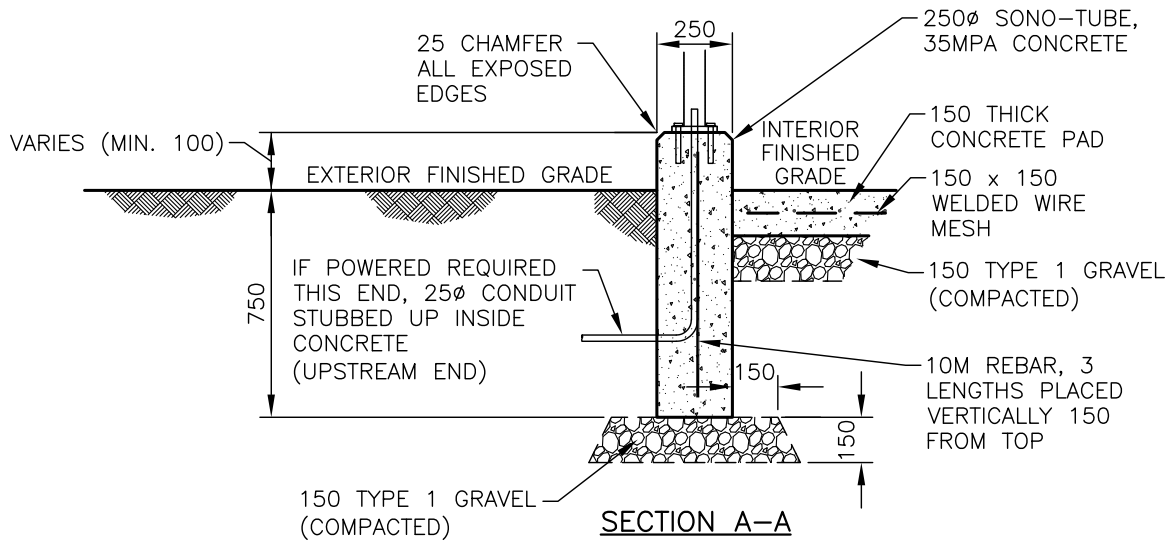

NOTES:

1. BEFORE ORDERING MATERIALS AND PRIOR TO CONSTRUCTION, VERIFY ALL EQUIPMENT AND SHELTER PLACEMENT/REQUIREMENTS WITH HALIFAX TRANSIT REPRESENTATIVE.
2. FOR INSTALLATION OF BUS SHELTER STRUCTURE FOLLOW MANUFACTURER'S INSTALLATION INSTRUCTIONS.
3. POWER CAN BE RUN INTO ANY OF THE SHELTER LEGS - CONTACT TRANSIT TO CONFIRM.
4. DIMENSIONS ARE IN MILLIMETRES.

HALIFAX

STANDARD DETAIL

**BUS STOP SHELTER ON
CONCRETE SONO-TUBES**

| | | |
|---------------|-----------|----------------------------|
| DATE: 2024 | REFERENCE | APPROVED |
| SCALE: NTS | | FIG No.: HRM 156 |

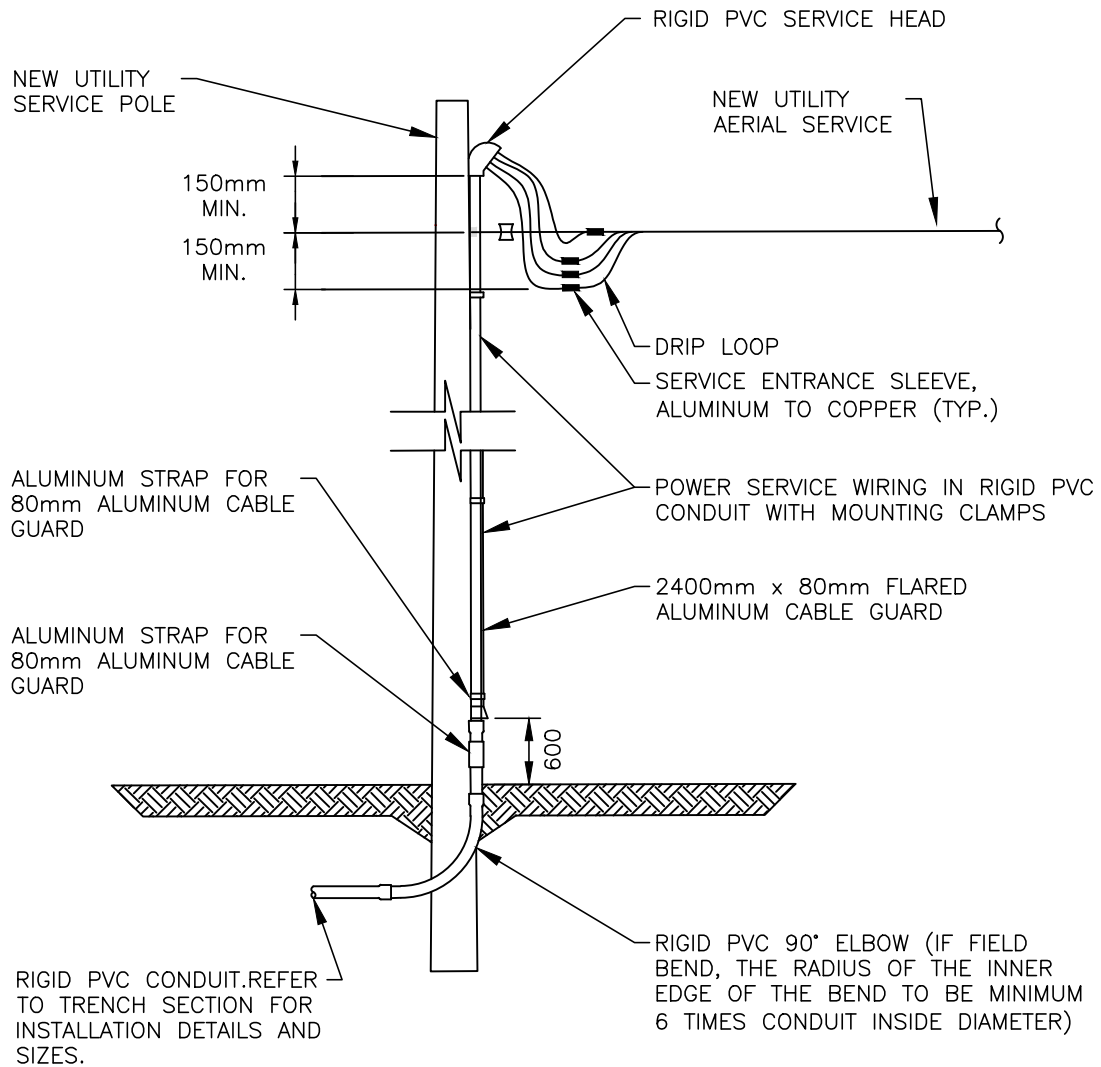

NOTES:

1. BREAKER MUST BE A DOUBLE POLE, NO SPARE SERVICE WIRES ARE ALLOWED.
2. CIRCUITS RATED AT MORE THAN 15Amps REQUIRE A CONTACTOR.
3. ALL WORK MUST BE IN COMPLIANCE WITH THE LATEST EDITION OF THE CANADIAN ELECTRICAL CODE AND INSPECTED BY NSPI
4. UNDERGROUND SERVICE CONDUIT AND GROUND MUST BE PROTECTED BY A U-GUARD AND BONDED AS PER CEC.
5. ALL SCREWS IN THE SERVICE SWITCH ARE TO BE NEVER SEIZED, AND MOUNTING SCREWS ARE TO BE STAINLESS STEEL ONLY.

HALIFAX

STANDARD DETAIL

UTILITY POLE
SERVICE DETAIL

| | | | |
|--------|------|-----------|----------------------------|
| DATE: | 2021 | REFERENCE | APPROVED |
| SCALE: | NTS | | FIG No.: HRM 160 |

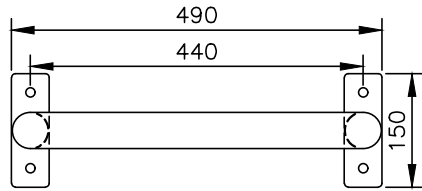

PLAN VIEW

HOT-DIPPED GALVANIZED STEEL OR
HOT-DIPPED GALVANIZED STEEL
WITH BLACK POWDER COAT

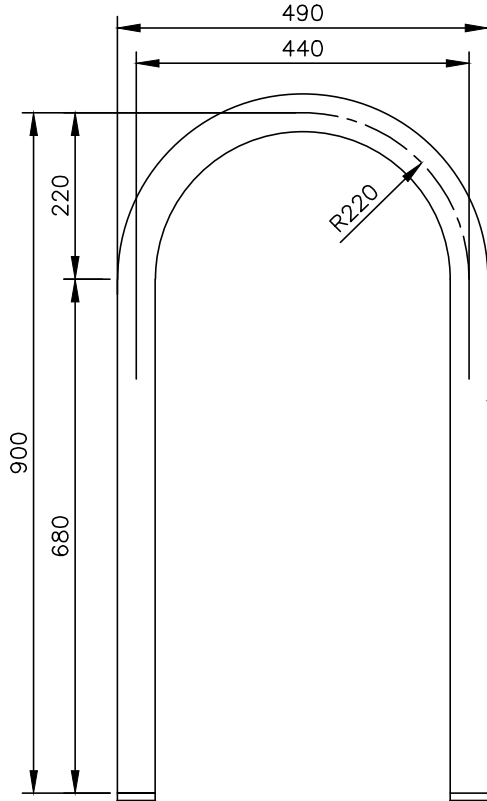

PROFILE VIEW

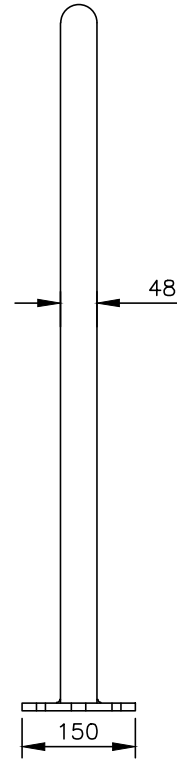

SECTION

48 O.D., 3.8 WT,
PIPE (38 DIA.,
SCHEDULE
40 PIPE)

10 X 50 X 150
BASEPLATE,
2 REQ'D (SEE
DETAIL)

NOTES:

1. ALL DIMENSIONS ARE IN MILLIMETRES.
2. VARIATION OF THE DIMENSIONS PROVIDED ARE PERMITTED, BUT MUST BE SHOWN ON SUBMITTED DRAWINGS.
3. BIKE RACKS TO BE ANCHORED TO POURED IN PLACE CONCRETE SURFACE WITH 10 mmØ X 125 mm EPOXY EXPANSION BOLTS (100 mm EMBEDMENT) OR APPROVED EQUIVALENT.

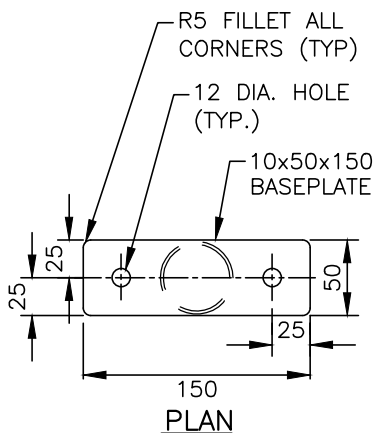

BASEPLATE DETAIL

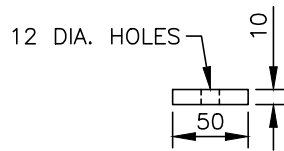

SECTION

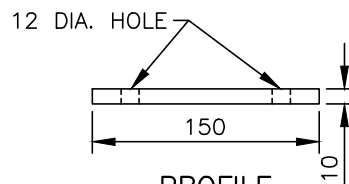

PROFILE

HALIFAX

STANDARD DETAIL

INVERTED U BIKE RACK

| | | | |
|--------|------|-----------|---------------------|
| DATE: | 2021 | REFERENCE | APPROVED |
| SCALE: | NTS | | FIG No.: HRM 165 |

HOT-DIPPED GALVANIZED STEEL OR
HOT-DIPPED GALVANIZED STEEL WITH BLACK POWDER COAT

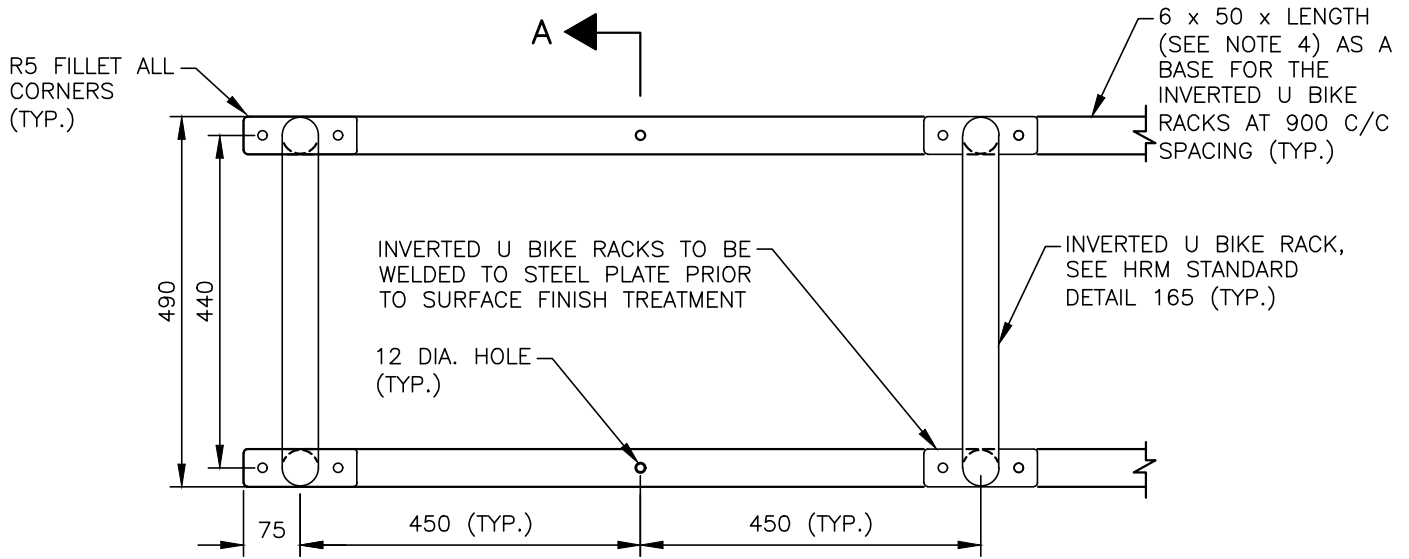

PLAN VIEW

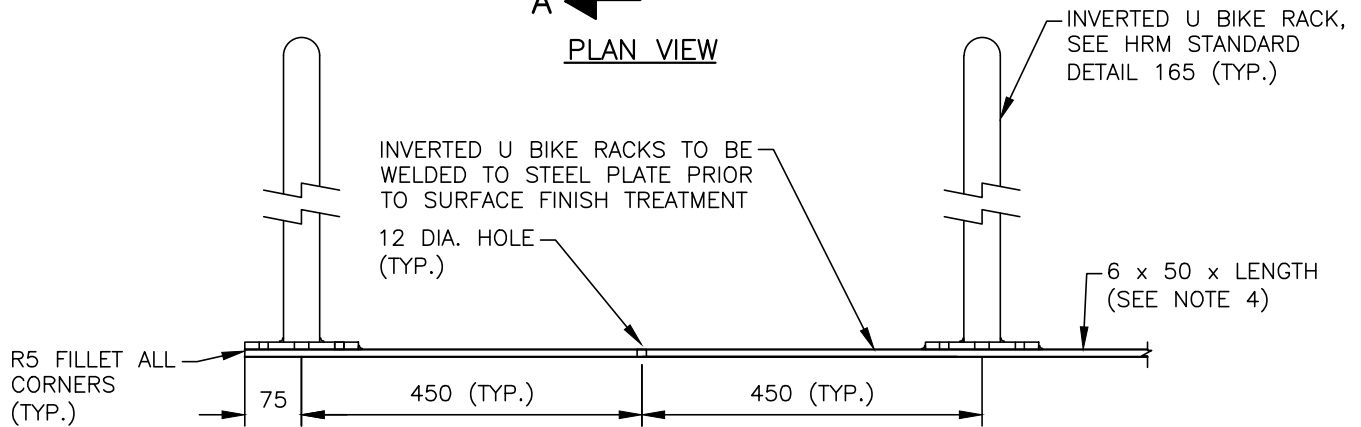

PROFILE VIEW

NOTES:

1. ALL DIMENSIONS ARE IN MILLIMETRES.
2. VARIATION OF THE DIMENSIONS PROVIDED ARE PERMITTED, BUT MUST BE SHOWN ON SUBMITTED DRAWINGS.
3. BIKE RACKS TO BE ANCHORED TO POURED IN PLACE CONCRETE SURFACE WITH 10 mm ϕ X 125 mm EPOXY EXPANSION BOLTS (100 mm EMBEDMENT) OR APPROVED EQUIVILANT.
4. MULTI BIKE RACK LENGTH WILL VARY FOR SERIES OF 2 TO 5 INVERTED U BIKE RACKS (AS REQUIRED).

INVERTED U BIKE RACK, SEE HRM STANDARD DETAIL 165

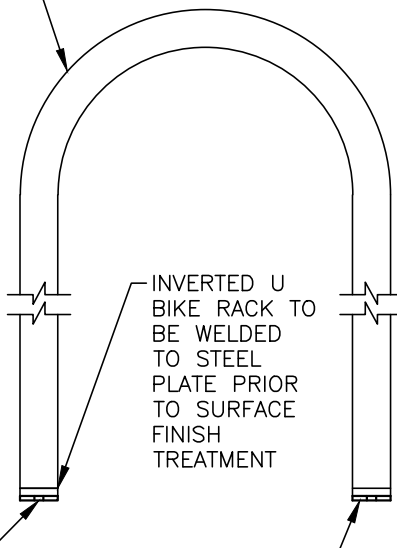

SECTION A-A

HALIFAX

STANDARD DETAIL

MULTI INVERTED U BIKE RACK

| | | | |
|--------|------|-----------|---------------------|
| DATE: | 2021 | REFERENCE | APPROVED |
| SCALE: | NTS | | FIG No.: HRM 166 |

HOT-DIPPED GALVANIZED STEEL OR
HOT-DIPPED GALVANIZED STEEL WITH
BLACK POWDER COAT

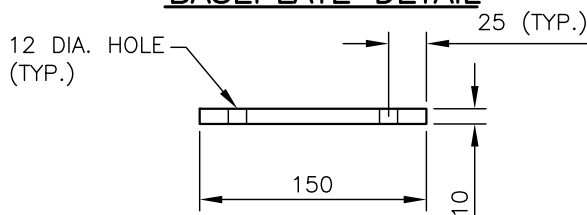
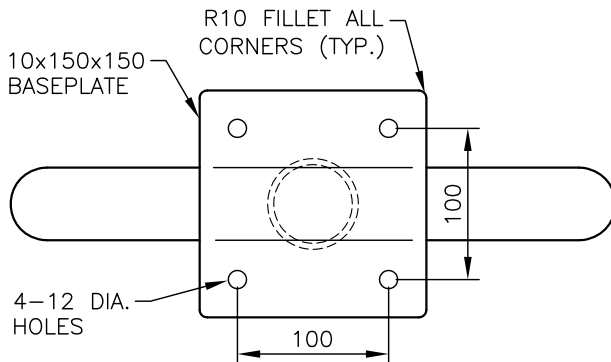
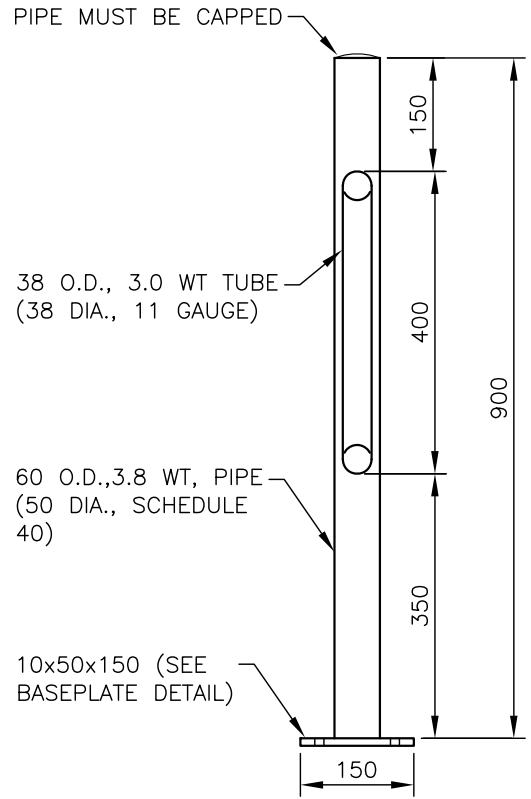
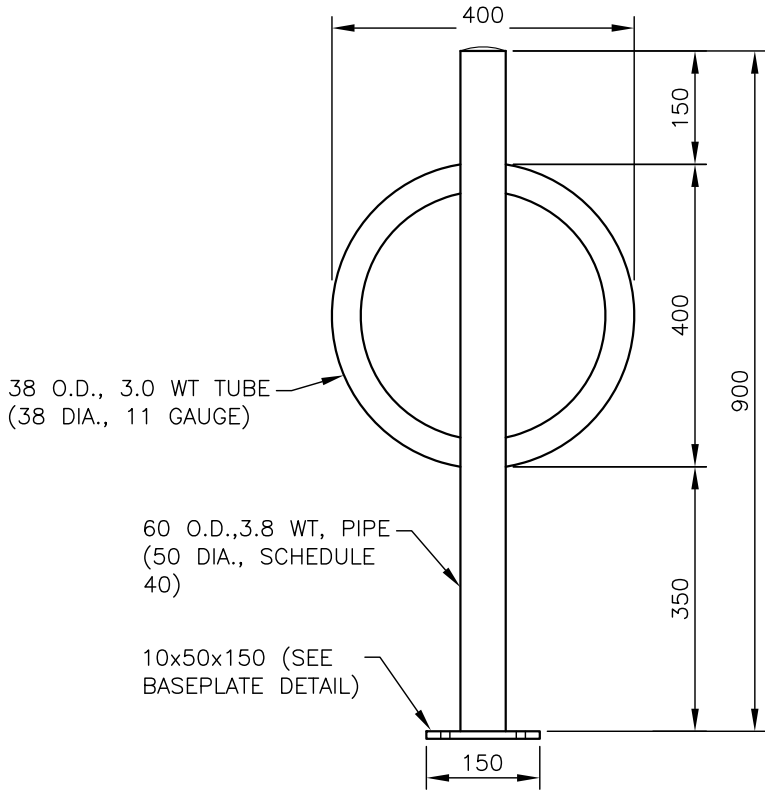
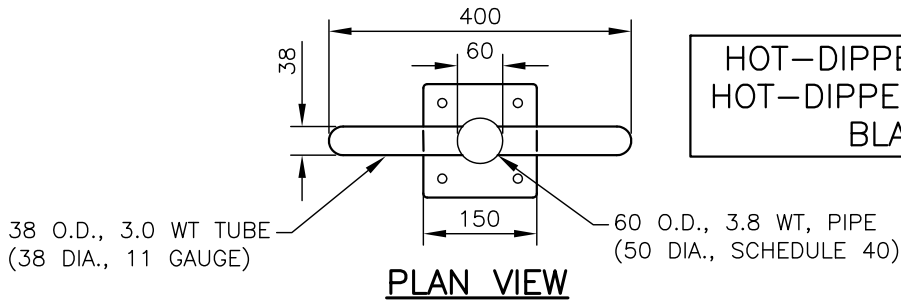

NOTES:

1. ALL DIMENSIONS ARE IN MILLIMETRES.
2. VARIATION OF THE DIMENSIONS PROVIDED ARE PERMITTED, BUT MUST BE SHOWN ON SUBMITTED DRAWINGS.
3. BIKE RACKS TO BE ANCHORED TO POURED IN PLACE CONCRETE SURFACE WITH 10 mmØ X 125 mm EPOXY EXPANSION BOLTS (100 mm EMBEDMENT).

HALIFAX

STANDARD DETAIL

POST & RING BIKE RACK

| | | |
|---------------|-----------|---------------------|
| DATE: 2021 | REFERENCE | APPROVED |
| SCALE: NTS | | FIG No.: HRM 167 |

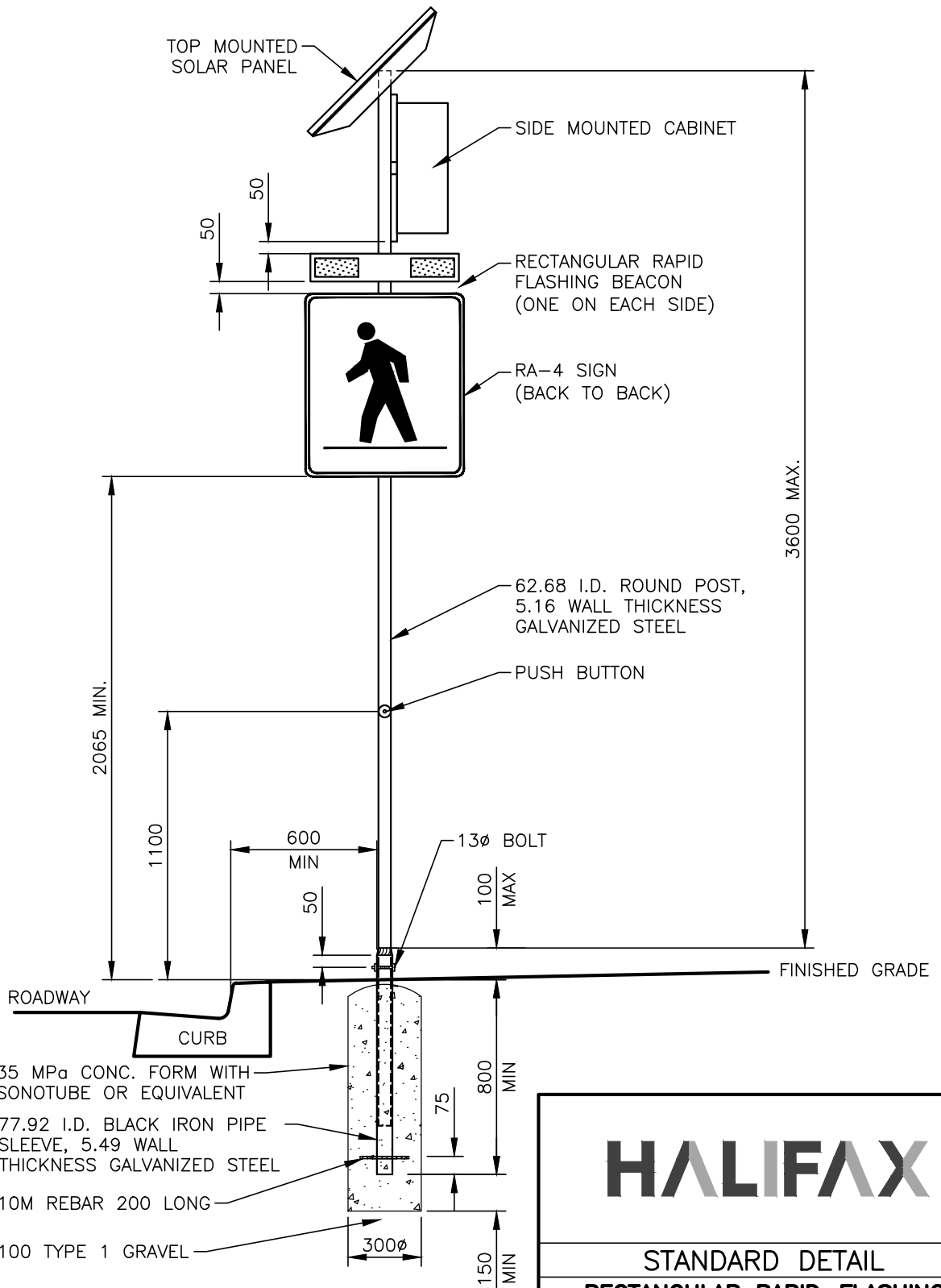

35 MPa CONC. FORM WITH SONOTUBE OR EQUIVALENT

77.92 I.D. BLACK IRON PIPE SLEEVE, 5.49 WALL THICKNESS GALVANIZED STEEL

10M REBAR 200 LONG

100 TYPE 1 GRAVEL

NOTE:

1. DIMENSIONS ARE IN MILLIMETRES.

HALIFAX

STANDARD DETAIL

RECTANGULAR RAPID-FLASHING BEACON SIGNAL CONFIGURATION (SOLAR CABINET-BASED)

| | | | |
|--------|------|-----------|----------|
| DATE: | 2023 | REFERENCE | APPROVED |
| SCALE: | 1:25 | FIG No.: | HRM 172 |

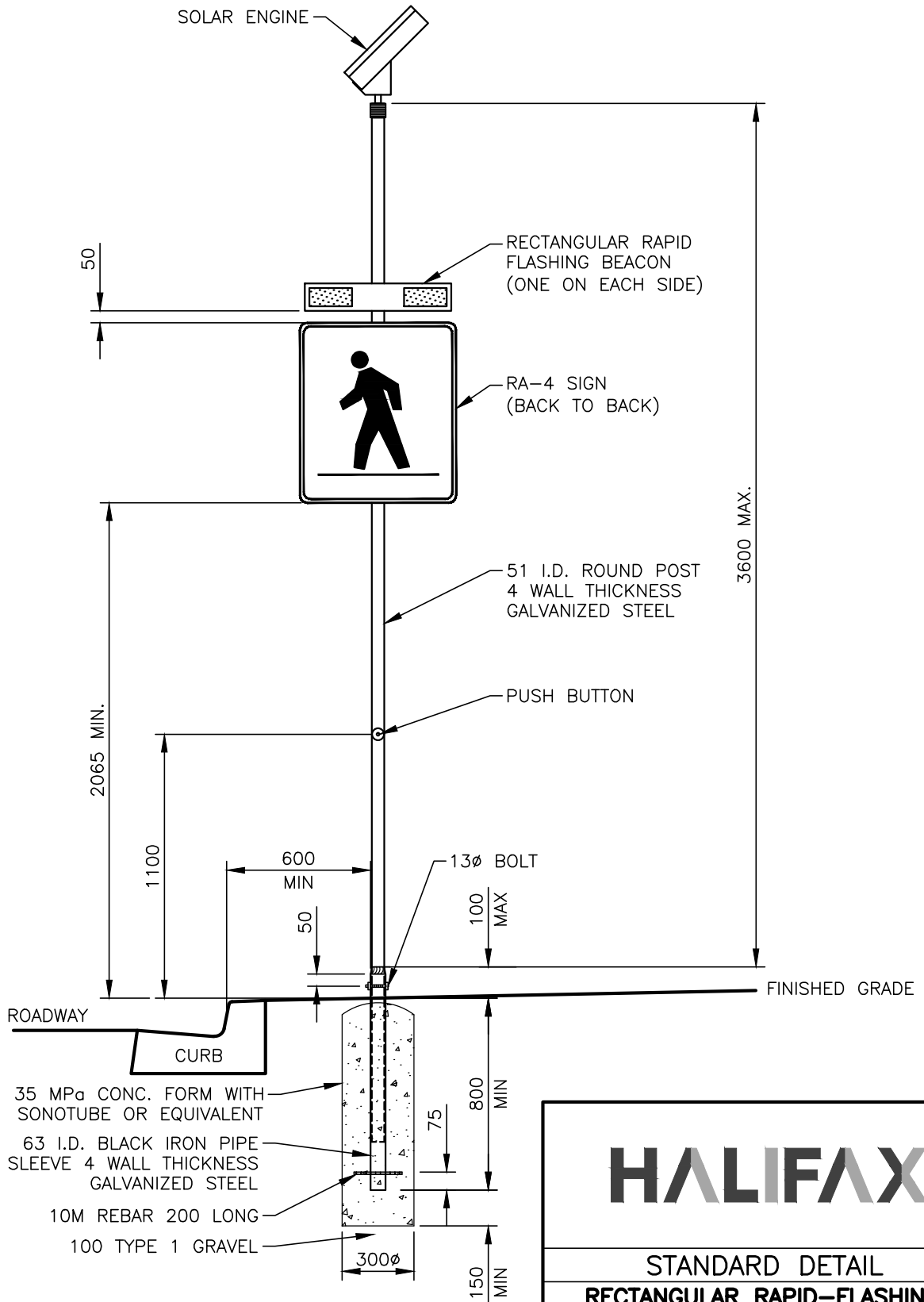

NOTE:

1. DIMENSIONS ARE IN MILLIMETRES.

HALIFAX

STANDARD DETAIL

RECTANGULAR RAPID-FLASHING BEACON SIGNAL CONFIGURATION (SOLAR SELF-CONTAINED)

| | | | |
|--------|------|-----------|---------------------|
| DATE: | 2023 | REFERENCE | APPROVED |
| SCALE: | 1:25 | | FIG No.: HRM 180 |

PROPOSED SOIL GROUPINGS

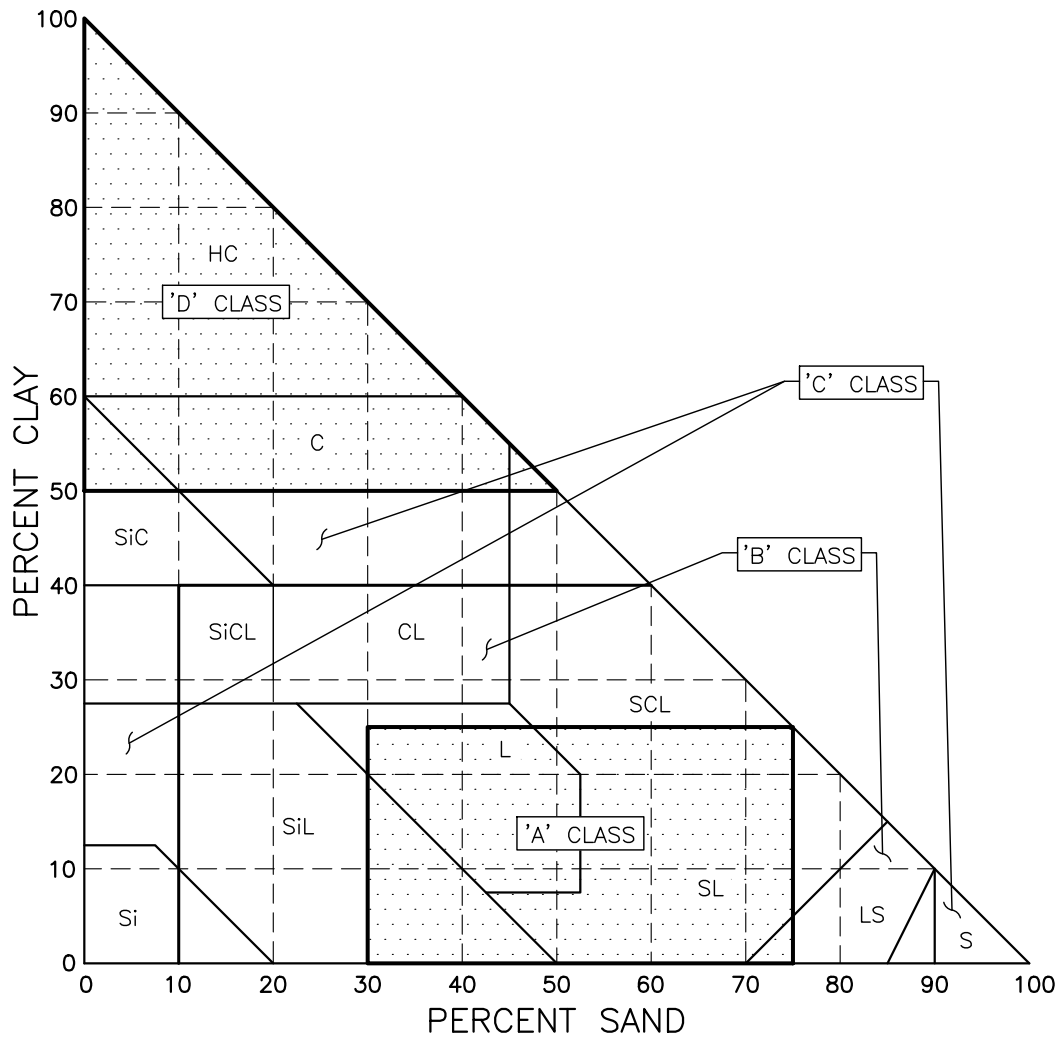

NOTES:

1. SOIL TEXTURE CLASSES. PERCENTAGES OF CLAY AND SAND IN THE MAIN TEXTURAL CLASSES OF SOIL; THE REMAINDER OF EACH CLASS IS SILT.

HALIFAX

STANDARD DETAIL

SOIL TEXTURE TRIANGLE

| | | | |
|--------|------|-----------|----------------|
| DATE: | 2021 | REFERENCE | APPROVED |
| SCALE: | NTS | | FIG No.: |
| | | | HRM 181 |

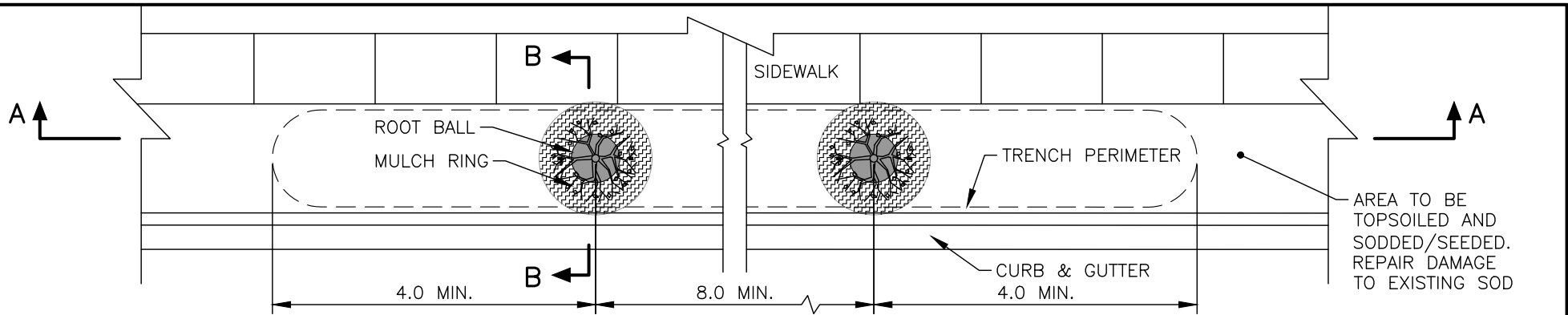

PLAN
SCALE 1:75

GALVANIZED GUY WIRE NO. 12 GAUGE (MIN.), WRAP GUY WIRE BACK ON ITSELF, ENDURE NO SHARP PROTRUSIONS (TYP.)

REFER TO SITE PLAN FOR SURFACE TREATMENT (TYP.)

TWO VERTICAL STAKES PER TREE:
 - MIN. 2.0m LENGTH T-BARS OR ROUND WOOD POSTS.
 - STAKES SET MIN. 600mm BELOW BASE OF ROOT BALL.
 - ALIGN STAKES WITH DIRECTION OF TRAFFIC.

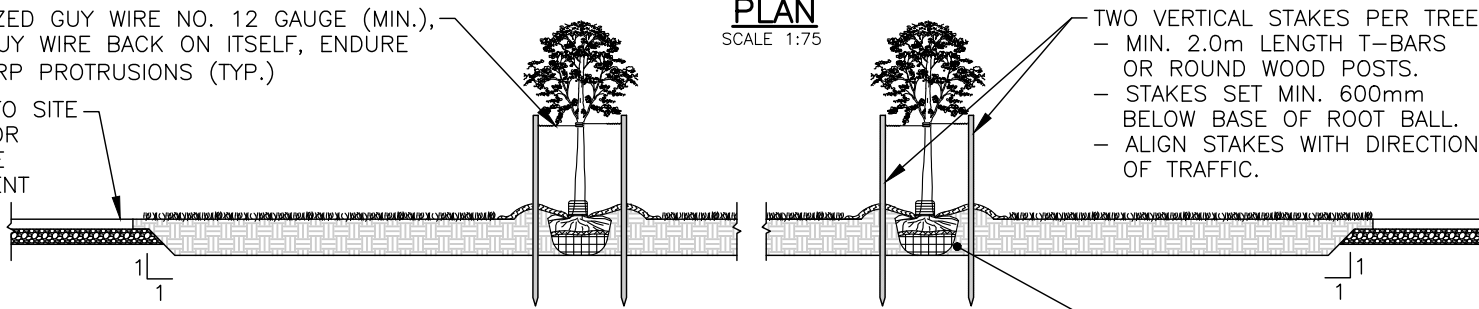

SECTION A-A
SCALE 1:75

TREE GUARD. ARBOGARD + AG9-4 OR APPROVED EQUAL
 ROOT COLLAR 50mm ABOVE GRADE

FOLD OR REMOVE TOP 1/3 WIRE BASKET AND/OR BURLAP FROM ROOT BALL

FORM A 100mm HIGH SOIL RING TO DIRECT WATER TO ROOT BALL

150mm TOPSOIL

SCARIFY BOTTOM AND WALLS OF TRENCH BEFORE PLACING ROOT BALL

DECIDUOUS TREE
 50-60mm CALIPER

PRUNE DEAD, BROKEN AND DISEASED TREE LIMBS
 RUBBER HOSE, POSITION APPROX. AT 3/5 HEIGHT FOR ALL TREES
 150mm DEPTH APPROVED MULCH
 BACKFILL TRENCH WITH TOPSOIL, COMPACT JUST TO ENSURE STABILITY OF ROOT BALL
 REPAIR ANY DAMAGED SEED/SOD TO HRM STANDARDS
 SIDEWALK

BACKFILL TRENCH WITH TOPSOIL, COMPACT TO MAXIMUM 85% SPD, ENSURE STABILITY OF ROOTBALL.

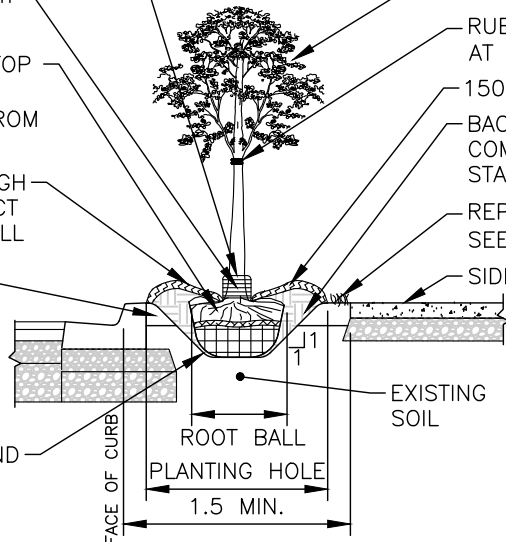

SECTION B-B
SCALE 1:50

NOTES:

1. SOAK THE ROOTBALL AND BACKFILL AREA WITH 40 LITRES OF WATER AFTER PLANTING
2. ROOT BALL MIN. SIZE AS PER CNLA STANDARDS FOR NURSERY STOCK
3. MINIMUM TRENCH LENGTH: 8m PER TREE UNLESS APPROVED BY URBAN FORESTER

HALIFAX

STANDARD DETAIL

TREE PLANTING
 IN SOD BOULEVARD

| | | | |
|--------|----------|-----------|----------|
| DATE: | 2021 | REFERENCE | APPROVED |
| SCALE: | AS NOTED | FIG No.: | HRM 182 |

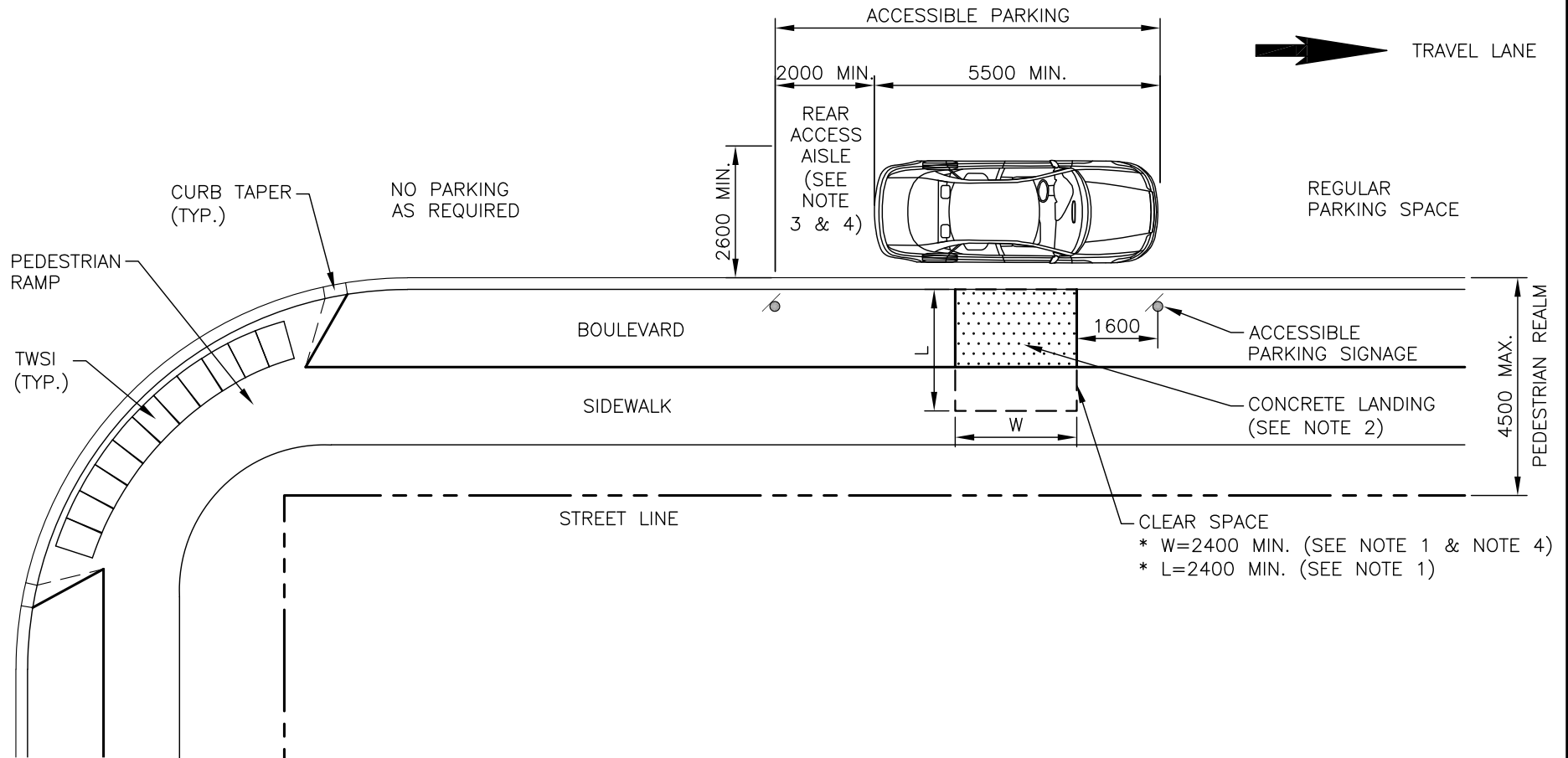

NOTES:

1. CLEAR SPACE SHALL BE PROVIDED WITH NO OBSTRUCTIONS AT PASSENGER SIDE DOOR LOCATIONS.
2. CONCRETE LANDING SHALL BE INSTALLED WITH NEW CONSTRUCTION, STREET/SIDEWALK REHABILITATION WHEN GRASS BOULEVARD SEPARATES PARKING AND ADJACENT SIDEWALK.
3. IN ABSENCE OF SIGN POST INSTALLATION, UNMARKED REAR ACCESS AISLE CAN BE REDUCED TO 1500 MIN WHERE 2000 MIN. IS NOT FEASIBLE.
4. IN RETROFIT SITUATIONS WHERE IT IS NOT TECHNICALLY FEASIBLE TO PROVIDE THE REQUIRED WIDTH FOR THE REAR ACCESS AISLE OR CLEAR SPACE LENGTH DUE TO TREE OR UTILITY POLE LOCATIONS, WIDTH MAY BE REDUCED TO 1500 MIN.
5. WHERE SIDEWALK ABUTS THE CURB THE ADJACENT SIDEWALK SHALL BE 2400 MINIMUM WIDTH.
6. FOR USE ONLY WITHIN 20 METRES OF AN ACCESSIBLE PEDESTRIAN RAMP, AT THE DIRECTION OF THE ENGINEER.
7. ALL DIMENSION ARE IN MILLIMETRES.

HALIFAX

STANDARD DETAIL
ACCESSIBLE PARALLEL PARKING
BEGINNING OF BLOCK –
PEDESTRIAN REALM 4.5m OR LESS

| | | | |
|--------|------|-----------|----------|
| DATE: | 2024 | REFERENCE | APPROVED |
| SCALE: | NTS | FIG No.: | HRM 193 |

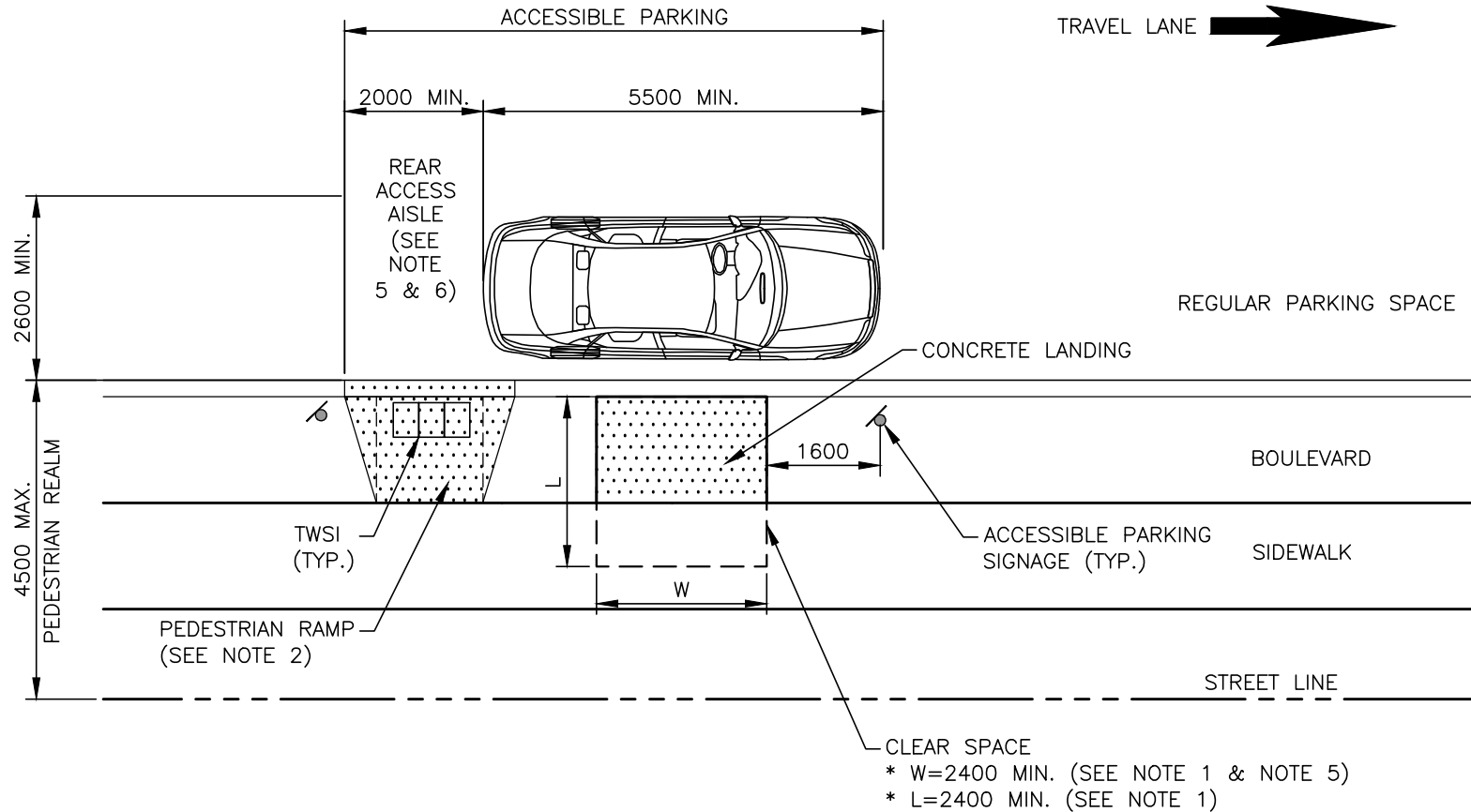

NOTES:

1. CLEAR SPACE SHALL BE PROVIDED WITH NO OBSTRUCTIONS AT PASSENGER SIDE DOOR LOCATIONS.
2. REFER TO HRM DETAIL 49 FOR CURB RAMP DETAILS.
3. TACTILE WALKING SURFACE INDICATOR (TWSI) PLATES REQUIRED AT ALL NEW RAMPS AS PER HRM DETAIL 131.
4. CONCRETE LANDING SHALL BE INSTALLED WITH NEW CONSTRUCTION, STREET/SIDEWALK REHABILITATION WHEN GRASS BOULEVARD SEPARATES PARKING AND ADJACENT SIDEWALK.
5. IN RETROFIT SITUATIONS WHERE IT IS NOT TECHNICALLY FEASIBLE TO PROVIDE THE REQUIRED WIDTH FOR THE REAR ACCESS AISLE OR CLEAR SPACE LENGTH DUE TO TREE OR UTILITY POLE LOCATIONS, WIDTH MAY BE REDUCED TO 1500 MIN.
6. IN ABSENCE OF SIGN POST INSTALLATION, UNMARKED REAR ACCESS AISLE CAN BE REDUCED TO 1500 MIN WHERE 2000 MIN IS NOT FEASIBLE.
7. WHEN DRIVEWAY USED AS SIDEWALK ACCESS INSTEAD OF CURB RAMP, NO TWSI PLATES SHALL BE REQUIRED.
8. WHERE SIDEWALK ABUTS THE CURB THE ADJACENT SIDEWALK SHALL BE 2400 MINIMUM WIDTH.

HALIFAX

STANDARD DETAIL

**ACCESSIBLE PARALLEL PARKING
 MID-BLOCK AND END OF BLOCK –
 PEDESTRIAN REALM 4.5 m OR LESS**

| | | | |
|--------|------|-----------|---------------------|
| DATE: | 2023 | REFERENCE | APPROVED |
| SCALE: | NTS | | FIG No.: HRM 194 |

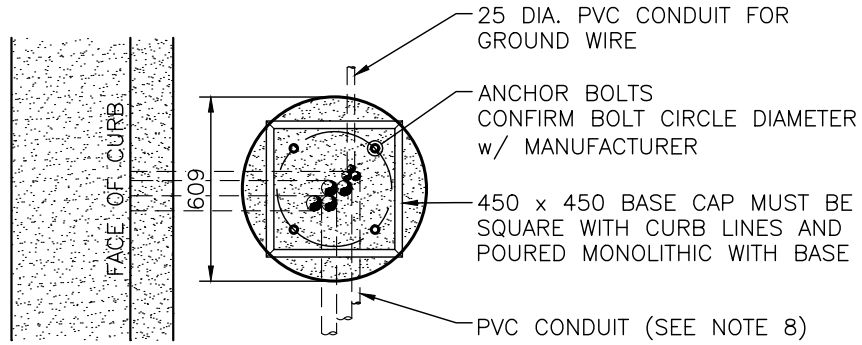

PLAN

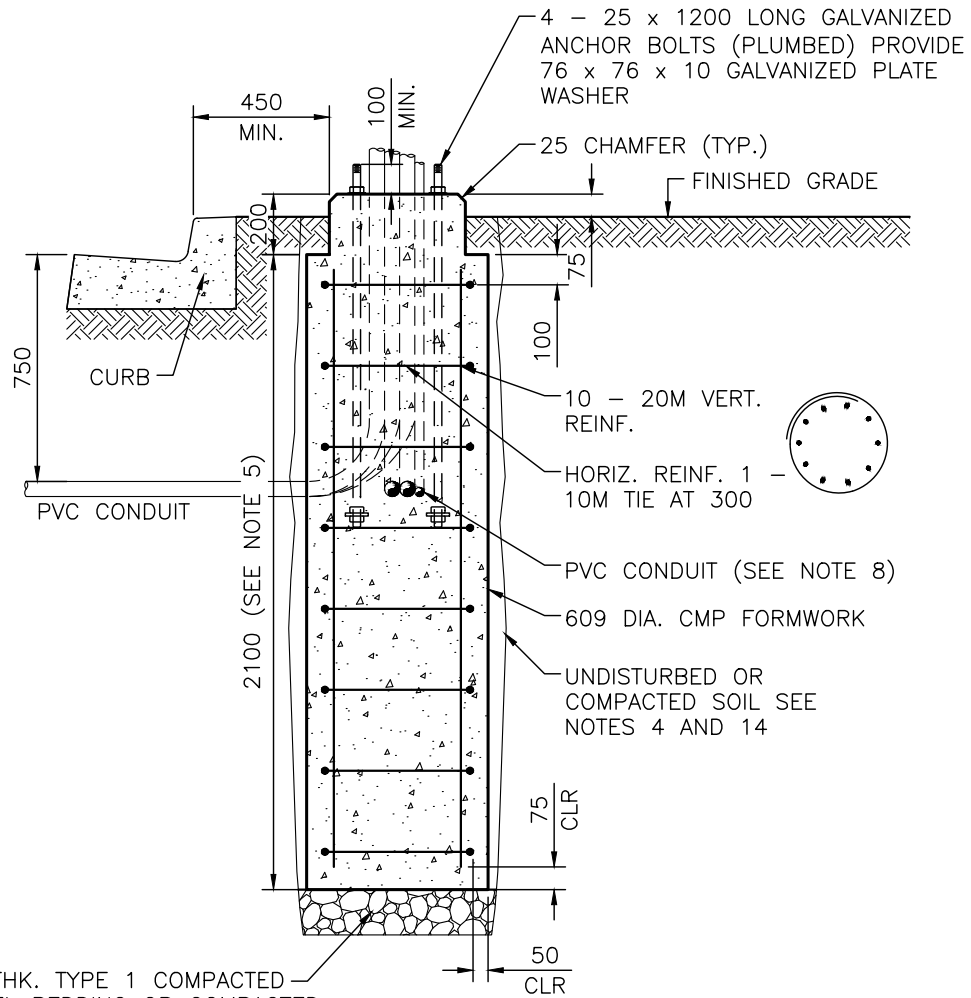

SECTION

NOTES:

1. SEE HRM 68N3, SELECTION GUIDE, FOR PERMITTED POLES AND TRAFFIC SIGNAL EQUIPMENT.
2. FOR NOTES REFER TO HRM 68N1.
3. DIMENSIONS ARE IN MILLIMETRES.

| | | |
|--|-----------|----------|
| HALIFAX | | |
| STANDARD DETAIL | | |
| TRAFFIC SIGNAL BASE FOR CONFIGURATION A | | |
| DATE: | REFERENCE | APPROVED |
| 2021 | | |
| SCALE: | | FIG No.: |
| 1:25 | | HRM 68 |

NOTES FOR SHAFT FOUNDATIONS ONLY:

1. ALL DIMENSIONS IN MILLIMETRES UNLESS OTHERWISE SHOWN.
2. CONCRETE 28 DAY STRENGTH TO BE 35 MPa, CLASS OF EXPOSURE 'C1', AIR CONTENT 5 – 8%.
3. ENGINEER TO CONFIRM SOIL PARAMETERS BEFORE PROCEEDING WITH WORK.
4. DESIGN IS FOR DRY SOIL CONDITIONS (NO GROUND WATER TABLE) WITH A MINIMUM $\gamma_{SOIL} = 18 \text{ kN/m}^3$, $K_p = 3.5$, $\phi = 34^\circ$.
5. WHERE SOUND BEDROCK IS ENCOUNTERED, FOUNDATION CONSTRUCTION MAY BE MODIFIED TO USE ROCK ANCHORS DOWELED INTO ROCK. REFER TO DRAWING No. 74B.1 AND 74B.2.
6. ANCHORS TO BE MINIMUM GRADE A307, PLATE WASHERS MINIMUM GRADE 300W.
7. CONTRACTOR TO CONFIRM ANCHOR BOLT DIAMETER, LENGTH AND BOLT CIRCLE PRIOR TO PROCEEDING WITH WORK.
8. PROPOSED PVC CONDUIT SIZE AND CONFIGURATION INDICATED ON DRAWINGS. CONDUITS ARE ASSUMED TO BE "BUNCHED" AND IN CENTRE OF PEDESTAL. FOR PEDESTAL WITH NOMINAL DIAMETER OF D-NOM, DIAMETER OF "BUNCHED" CONDUIT AT TOP OF CONCRETE SHALL BE D-B MAXIMUM. IF "BUNCHED" DIAMETER AT TOP OF CONCRETE IS GREATER THAN D-B, USE D-ADJ DIA. PEDESTAL.

| D-NOM | D-B | D-ADJ |
|-------|-----|-------|
| 609 | 150 | 762 |
| 762 | 250 | 914 |
| 914 | 300 | 1067 |

9. CONCRETE MUST BE PLACED IN A SINGLE POUR.
10. EMBEDMENT DEPTH OF THE FOUNDATION WAS DERIVED FROM THE ONTARIO MINISTRY OF TRANSPORTATION ENGINEERING STANDARDS BRANCH – GUIDELINES FOR THE DESIGN OF HIGH MAST POLE FOUNDATIONS, 4TH Ed. 2004.
11. TORSIONAL RESISTANCE OF THE FOUNDATION WAS COMPLETED BASED ON BROM'S TORSION LOADING ANALYSIS OF SHORT SINGLE SHAFT FOUNDATIONS.
12. RESIDUAL FRICTIONAL COEFFICIENT (μ) BETWEEN THE CIRCUMFERENCE OF THE FOUNDATION AND SOIL IS TO BE 0.3.
13. WHERE FINISHED GRADE IS LOWER NEAR POLE BASE, HEIGHT OF FOUNDATION TO BE INCREASED AS FOLLOWS:

- 'A' UP TO 0.3m, NO INCREASE.
- 'A' UP TO 0.6m, INCREASE HEIGHT BY 0.2m.
- 'A' UP TO 1.0m, INCREASE HEIGHT BY 0.4m.

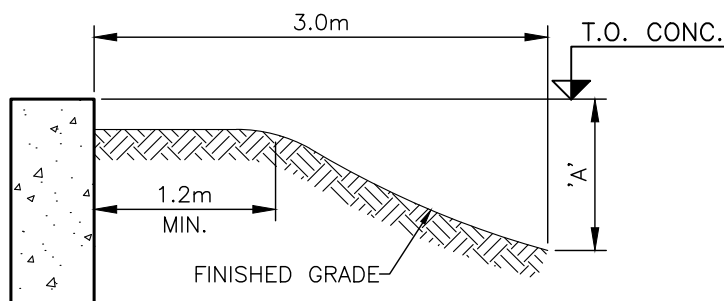

14. ENSURE FULLY COMPACTED SOIL AROUND FOUNDATION.

| | | |
|--------------------------|------|-----------------------------|
| HALIFAX | | |
| STANDARD DETAIL | | |
| STANDARD NOTES | | |
| SHAFT FOUNDATIONS | | |
| DATE: | 2021 | REFERENCE |
| SCALE: | NTS | APPROVED |
| | | FIG No.: HRM 68N1 |

NOTES FOR SPREAD FOUNDATIONS ONLY:

1. ALL DIMENSIONS IN MILLIMETRES UNLESS OTHERWISE SHOWN.
2. CONCRETE 28 DAY STRENGTH TO BE 35 MPa, CLASS OF EXPOSURE 'C1', AIR CONTENT 5 – 8%.
3. ENGINEER TO CONFIRM SOIL PARAMETERS BEFORE PROCEEDING WITH WORK.
4. DESIGN IS FOR DRY SOIL CONDITIONS (NO GROUND WATER TABLE) WITH A MINIMUM $\gamma_{\text{SOIL}} = 18 \text{ kN/m}^3$, $K_p = 3.5$, $\phi = 34^\circ$.
5. WHERE SOUND BEDROCK IS ENCOUNTERED, FOUNDATION CONSTRUCTION MAY BE MODIFIED TO USE ROCK ANCHORS DOWELED INTO ROCK. REFER TO DRAWING No. 74B.1 AND 74B.2.
6. ANCHORS TO BE MINIMUM GRADE A307, PLATE WASHERS MINIMUM GRADE 300W.
7. CONTRACTOR TO CONFIRM ANCHOR BOLT DIAMETER, LENGTH AND BOLT CIRCLE PRIOR TO PROCEEDING WITH WORK.
8. PROPOSED PVC CONDUIT SIZE AND CONFIGURATION INDICATED ON DRAWINGS. CONDUITS ARE ASSUMED TO BE "BUNCHED" AND IN CENTRE OF PEDESTAL. FOR PEDESTAL WITH NOMINAL DIAMETER OF D-NOM, DIAMETER OF "BUNCHED" CONDUIT AT TOP OF CONCRETE SHALL BE D-B MAXIMUM. IF "BUNCHED" DIAMETER AT TOP OF CONCRETE IS GREATER THAN D-B, USE D-ADJ DIA. PEDESTAL.

| D-NOM | D-B | D-ADJ |
|-------|-----|-------|
| 609 | 150 | 762 |
| 762 | 250 | 914 |
| 914 | 300 | 1067 |

9. FOOTINGS SHALL BEAR ON UNDISTURBED SOIL, STRUCTURAL FILL OR BEDROCK WITH A MINIMUM SERVICEABILITY LIMIT STATES (SLS) BEARING CAPACITY OF 150kPa AND A MINIMUM ULTIMATE LIMIT STATES (ULS) BEARING CAPACITY OF 250kPa.
10. TORSIONAL RESISTANCE ANALYSIS WAS COMPLETED CONSIDERING PASSIVE SOIL PRESSURE AT THE VERTICAL FACE OF THE FOOTINGS AND A FRICTION (μ) BETWEEN THE UNDERSIDE OF THE FOOTING AND SOIL OF 0.4.
11. FINISHED GRADE ELEVATIONS SHALL NOT VARY MORE THAN 150mm OVER A DISTANCE EQUAL TO TWICE THE EMBEDMENT DEPTH.
12. AFTER CONSTRUCTION, CUT OFF TOP OF CMP FORMWORK TO 150mm BELOW FINISHED GRADE.

HALIFAX

STANDARD DETAIL

STANDARD NOTES
SPREAD FOOTINGS

| | | | |
|--------|------|-----------|-----------------------------|
| DATE: | 2021 | REFERENCE | APPROVED |
| SCALE: | NTS | | FIG No.: HRM 68N2 |

**TRAFFIC SIGNAL POLE BASE DESIGN SELECTION GUIDE FOR TYPE OF POLE BASE
MAXIMUM DESIGN CRITERIA USED FOR DIFFERENT TYPES OF POLE BASES**

| CONFIGURATION | POLE TYPE | | | TRAFFIC SIGNAL EQUIPMENT | | | | PEDESTRIAN HEADS | STREET LIGHTING | SIGNAGE AREA (m ²) | POLE BASE DESIGN TYPE | HRM STANDARD DETAIL NO. |
|---------------|-----------|----------------|----------------------------------|--------------------------|-------------|-------------|-------------------------|------------------|-----------------|--------------------------------|-----------------------|-------------------------|
| | MATERIAL | BASE DIA. (mm) | TOTAL HEIGHT (m) (SEE NOTE 4) | MAST ARMS | | | SIGNAL HEADS (PER POLE) | | | | | |
| | | | | NO. | LENGTH (m) | ORIENTATION | | | | | | |
| A | ALUM. | 203 | 5.2 | 0 | N.A. | N.A. | 2 | 2 | 1@0.4 | 0 | 1 | 68 |
| B | ALUM. | 203 | 5.8 | 1 | 4.6 | N.A. | 2 | 2 | NONE | 0.7 | 2 | 69 |
| C | ALUM. | 203 | 5.8 | 2 | 4.6, TOTAL | 180° | 2 | 2 | NONE | 0.7 | 2 | 69 |
| D | ALUM. | 203 | 5.8 | 2 | 3.1 EACH | 90° | 2 | 2 | NONE | 0.7 | 2 | 69 |
| E | ALUM. | 254 | 8.2 | 0 | N.A. | N.A. | 0 | 0 | 2@1.85 | 0 | 2 | 69 |
| F | ALUM. | 254 | 6.7 | 1 | 6.1 | N.A. | 2 | 2 | NONE | 0.7 | 3 | 70 |
| G | ALUM. | 254 | 6.7 | 2 | 6.1, TOTAL | 180° | 2 | 2 | NONE | 0.7 | 3 | 70 |
| H | ALUM. | 254 | 6.7 | 2 | 3.6 EACH | 90° | 2 | 2 | NONE | 0.7 | 3 | 70 |
| I | ALUM. | 254 | 6.7 | 1 | 7.6 | N.A. | 2 | 2 | NONE | 0.7 | 4 | 71 |
| J | ALUM. | 254 | 6.7 | 2 | 7.6, TOTAL | 180° | 2 | 2 | NONE | 0.7 | 4 | 71 |
| K | ALUM. | 254 | 6.7 | 2 | 4.6 EACH | 90° | 2 | 2 | NONE | 0.7 | 4 | 71 |
| L | ALUM. | 254 | 11.3 | 0 | N.A. | N.A. | 3 | 2 | 2@1.85 | 0 | 4 | 71 |
| M | ALUM. | 254 | 9.7 | 1 | 7.6 | N.A. | 2 | 2 | 1@1.8 | 0.7 | 4A | 71A |
| N | STEEL | 254 | 6.1 | 1 | 12.2 | N.A. | 4 | 2 | NONE | 0.7 | 5 | 72 |
| O | STEEL | 254 | 6.1 | 2 | 12.2, TOTAL | 180° | 5 | 2 | NONE | 0.7 | 5 | 72 |
| P | STEEL | 254 | 6.1 | 2 | 7.6 EACH | 90° | 5 | 2 | NONE | 0.7 | 5 | 72 |
| Q | STEEL | 343 | 10.7 | 1 | 12.2 | N.A. | 4 | 2 | 2@3.6m | 0.7 | 5A | 72A |
| R | STEEL | 343 | 10.7 | 2 | 12.2, TOTAL | 180° | 5 | 2 | 2@3.6m | 0.7 | 5A | 72A |
| S | STEEL | 343 | 10.7 | 2 | 7.6 EACH | 90° | 5 | 2 | 2@3.6m | 0.7 | 5A | 72A |
| T | STEEL | 343 | 6.1 | 1 | 18.3 | N.A. | 4 | 2 | NONE | 0.7 | 6 | 73 |
| U | STEEL | 343 | 6.1 | 2 | 18.3, TOTAL | 180° | 5 | 2 | NONE | 0.7 | 6 | 73 |
| V | STEEL | 343 | 6.1 | 2 | 10.7 EACH | 90° | 5 | 2 | NONE | 0.7 | 6 | 73 |
| W | STEEL | 343 | 10.7 | 1 | 18.3 | N.A. | 4 | 2 | 2@3.6m | 0.7 | 6A | 73A |
| X | STEEL | 343 | 10.7 | 2 | 18.3, TOTAL | 180° | 5 | 2 | 2@3.6m | 0.7 | 6A | 73A |
| Y | STEEL | 343 | 10.7 | 2 | 10.7 EACH | 90° | 5 | 2 | 2@3.6m | 0.7 | 6A | 73A |
| Z | STEEL | 343 | 6.1 | 1 | 21.3 | N.A. | 4 | 2 | NONE | 0.7 | 7 | 74 |
| AA | STEEL | 343 | 6.1 | 2 | 21.3, TOTAL | 180° | 5 | 2 | NONE | 0.7 | 7 | 74 |
| AB | STEEL | 343 | 6.1 | 2 | 12.2 EACH | 90° | 5 | 2 | NONE | 0.7 | 7 | 74 |
| AC | STEEL | 343 | 10.7 | 1 | 21.3 | N.A. | 4 | 2 | 2@3.6m | 0.7 | 7A | 74A |
| AD | STEEL | 343 | 10.7 | 2 | 21.3, TOTAL | 180° | 5 | 2 | 2@3.6m | 0.7 | 7A | 74A |
| AE | STEEL | 343 | 10.7 | 2 | 12.2 EACH | 90° | 5 | 2 | 2@3.6m | 0.7 | 7A | 74A |
| AF | ALUM. | 254 | 13.4 | 0 | N.A. | N.A. | 0 | 0 | 2@3.6m | 0.7 | 8 | 74X |

NOTES

- REFER TO HALIFAX STANDARD DRAWINGS 68 TO 74X FOR ADDITIONAL NOTES AND DESIGN CRITERIA.
- SEE STANDARD DRAWING NO. HRM 74B FOR REVISED POLE BASE FOUNDATION DESIGN WHICH MAY BE PERMITTED IN ROCK CONDITIONS.
- TRAFFIC SIGNAL POLE DESIGN CRITERIA MAY DIFFER FROM THAT AS SHOWN ON THIS TABLE. SHOULD THIS OCCUR, DESIGN ENGINEER SHALL BE CONSULTED FOR INTERPRETATION OF TABLE AND SELECTION OF POLE BASE TYPE, OR ADDITIONAL DESIGN IF REQUIRED.
- TOTAL POLE HEIGHT INDICATED INCLUDES A 0.61 m HIGH TRANSFORMER BASE.

HALIFAX

STANDARD DETAIL

**POLE BASE
SELECTION GUIDE**

| | | | |
|--------|------|-----------|-----------------------------|
| DATE: | 2021 | REFERENCE | APPROVED |
| SCALE: | NTS | | FIG No.: HRM 68N3 |

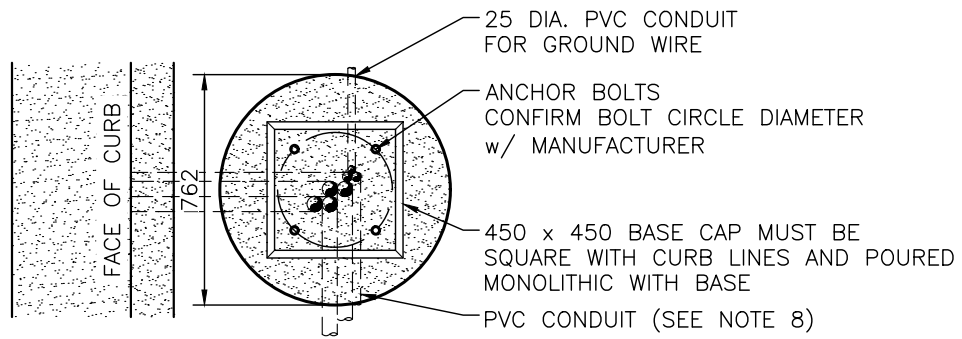

PLAN

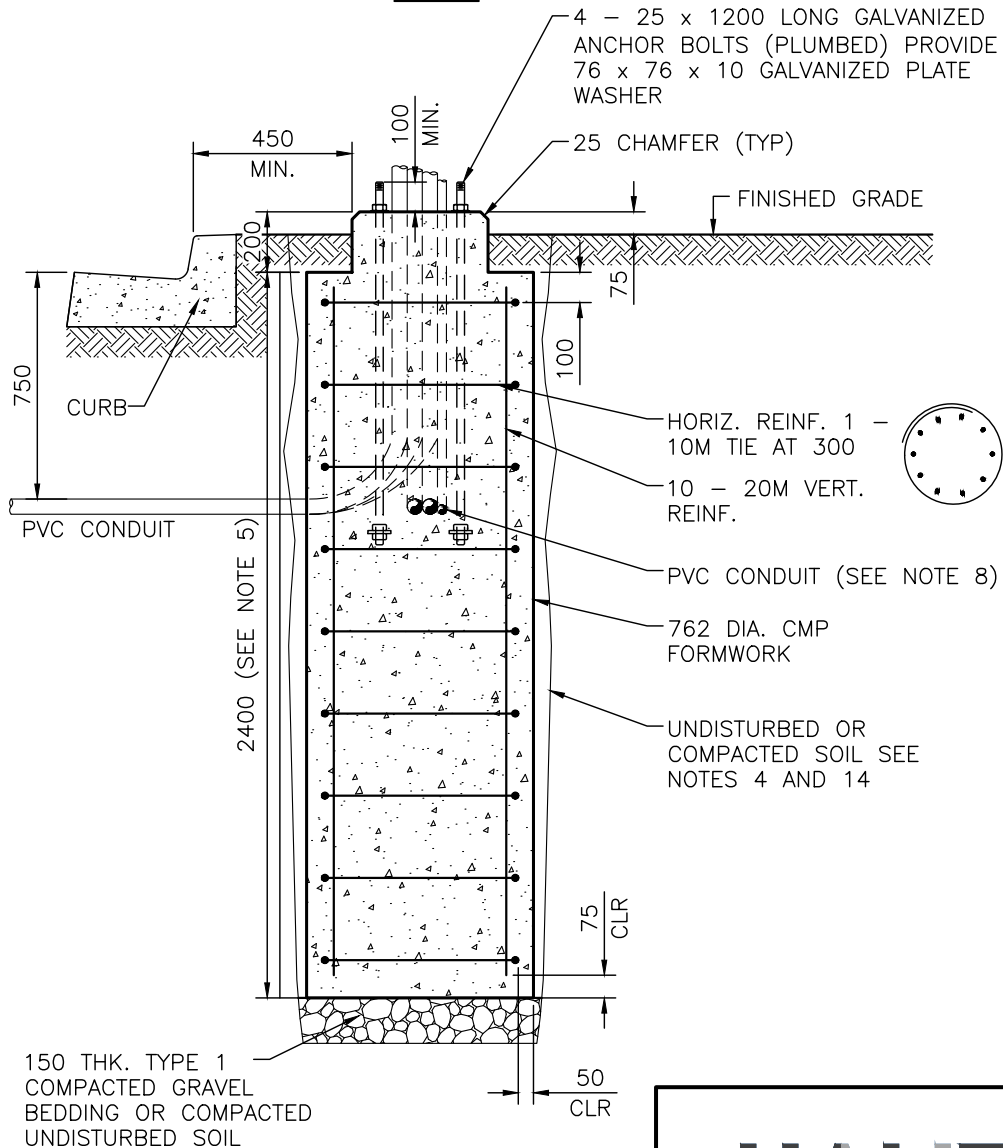

SECTION

NOTES:

1. SEE HRM 68N3, SELECTION GUIDE, FOR PERMITTED POLES AND TRAFFIC SIGNAL EQUIPMENT.
2. FOR NOTES REFER TO HRM 68N1.
3. DIMENSIONS ARE IN MILLIMETRES.

| | | |
|--|-----------|----------|
| HALIFAX | | |
| STANDARD DETAIL | | |
| TRAFFIC SIGNAL BASE FOR CONFIGURATIONS B, C, D AND E | | |
| DATE: | REFERENCE | APPROVED |
| 2021 | | |
| SCALE: | | FIG No.: |
| 1:25 | | HRM 69 |

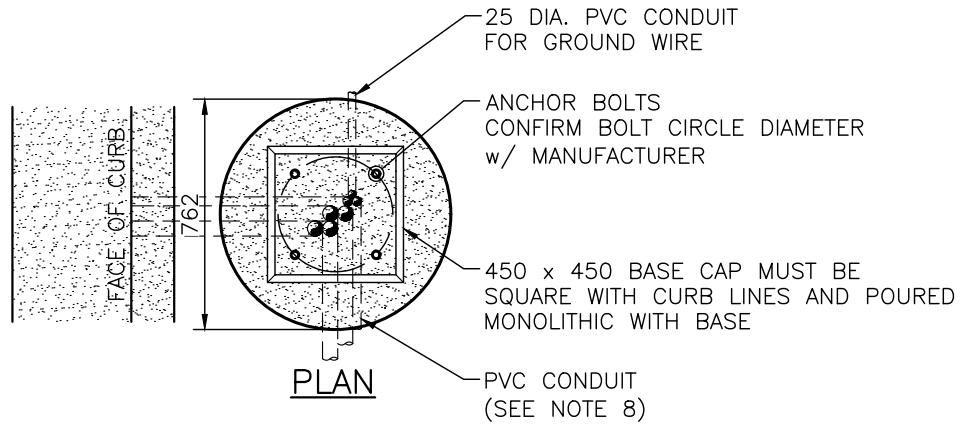

4 - 31 x 1000 LONG GALVANIZED ANCHOR BOLTS (PLUMBED) PROVIDE 76 x 76 x 10 GALVANIZED PLATE WASHER

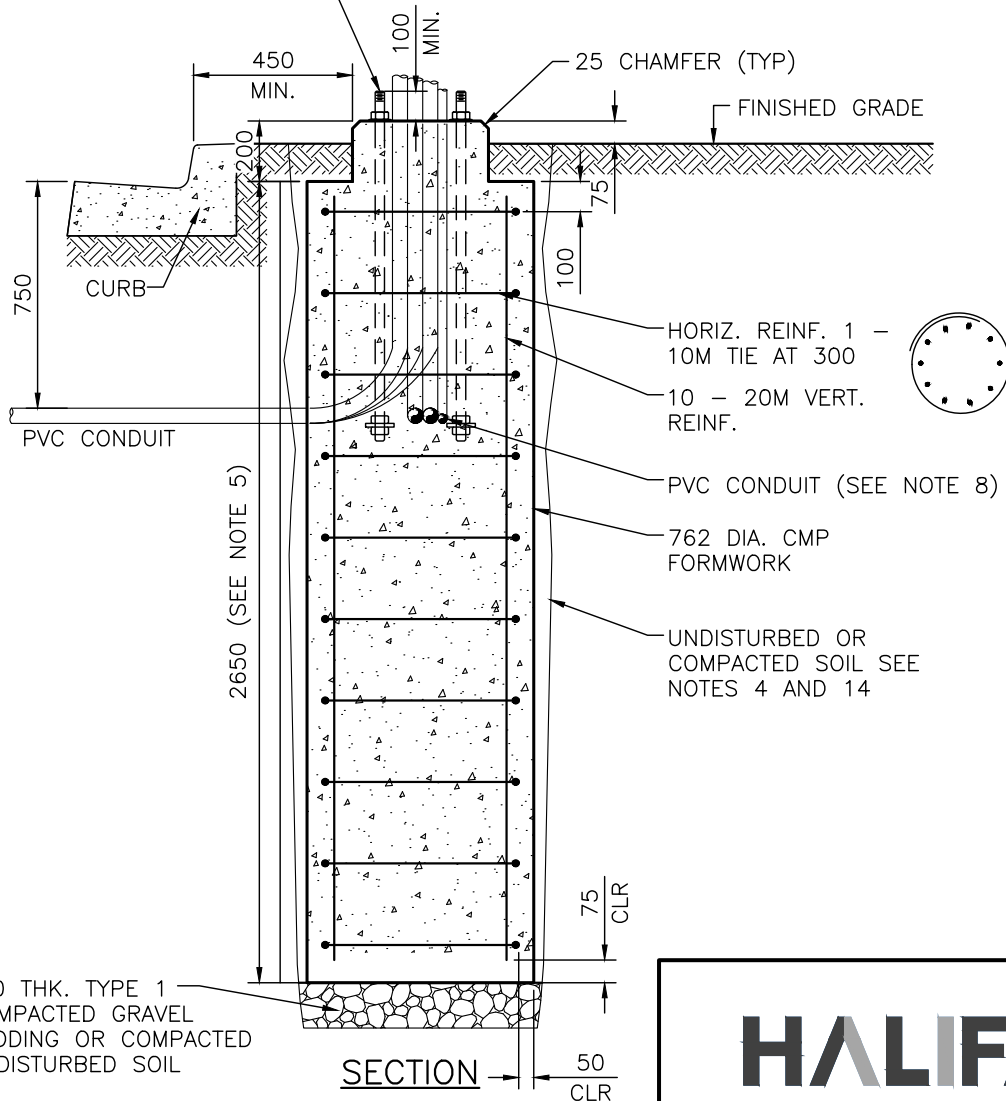

NOTES:

1. SEE HRM 68N3, SELECTION GUIDE, FOR PERMITTED POLES AND TRAFFIC SIGNAL EQUIPMENT.
2. FOR NOTES REFER TO HRM 68N1.
3. DIMENSIONS ARE IN MILLIMETRES.

| | | |
|---|-----------|----------|
| HALIFAX | | |
| STANDARD DETAIL | | |
| TRAFFIC SIGNAL BASE FOR CONFIGURATIONS F, G AND H | | |
| DATE: | REFERENCE | APPROVED |
| 2021 | | |
| SCALE: | | FIG No.: |
| 1:25 | | HRM 70 |

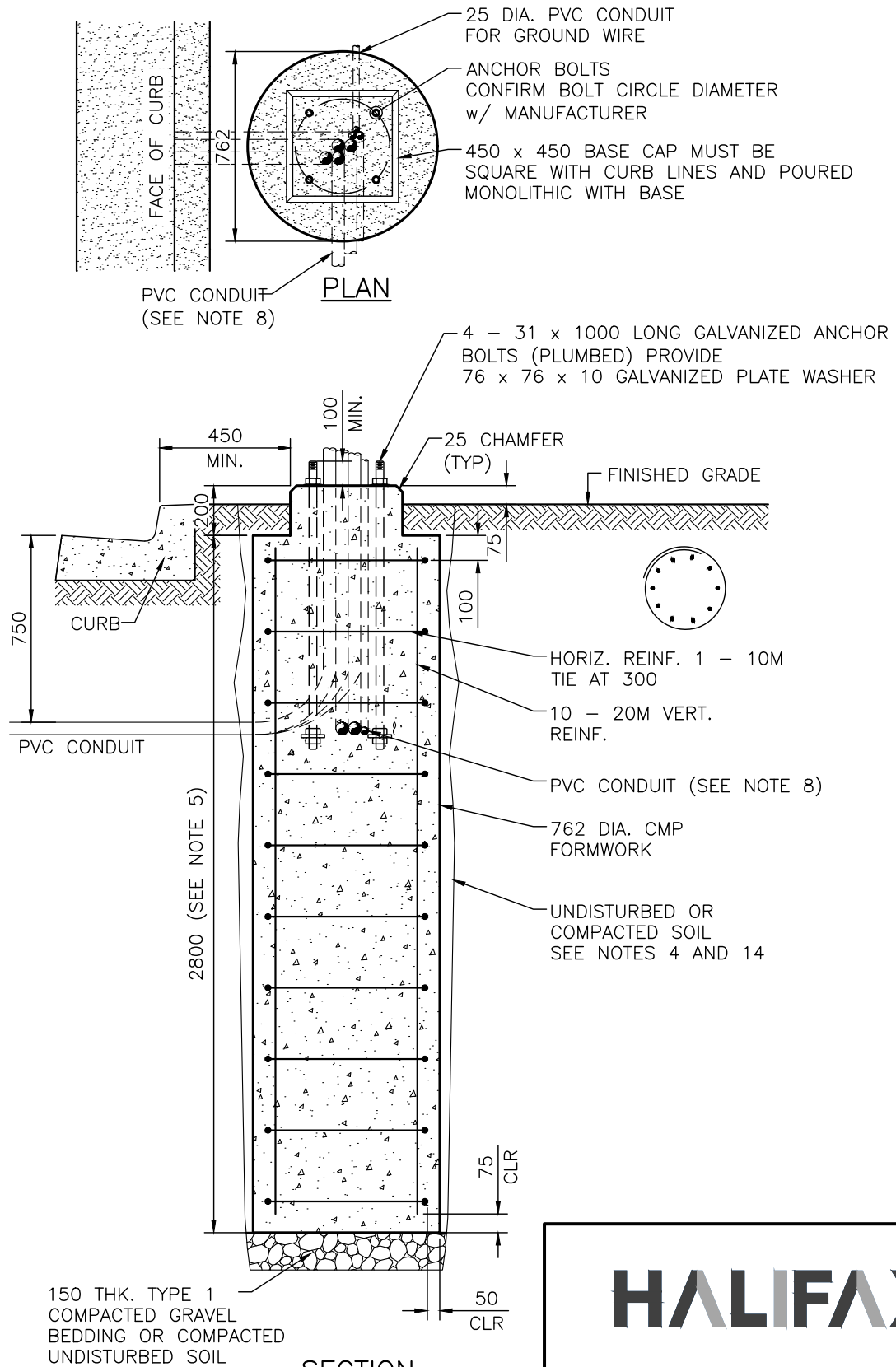

NOTES:

1. SEE HRM 68N3, SELECTION GUIDE, FOR PERMITTED POLES AND TRAFFIC SIGNAL EQUIPMENT.
2. FOR NOTES REFER TO HRM 68N1.
3. DIMENSIONS ARE IN MILLIMETRES.

| | | |
|---|-----------|----------|
| HALIFAX | | |
| STANDARD DETAIL | | |
| TRAFFIC SIGNAL BASE FOR CONFIGURATION I, J, K AND L | | |
| DATE: | REFERENCE | APPROVED |
| 2021 | | |
| SCALE: | | FIG No.: |
| 1:25 | | HRM 71 |

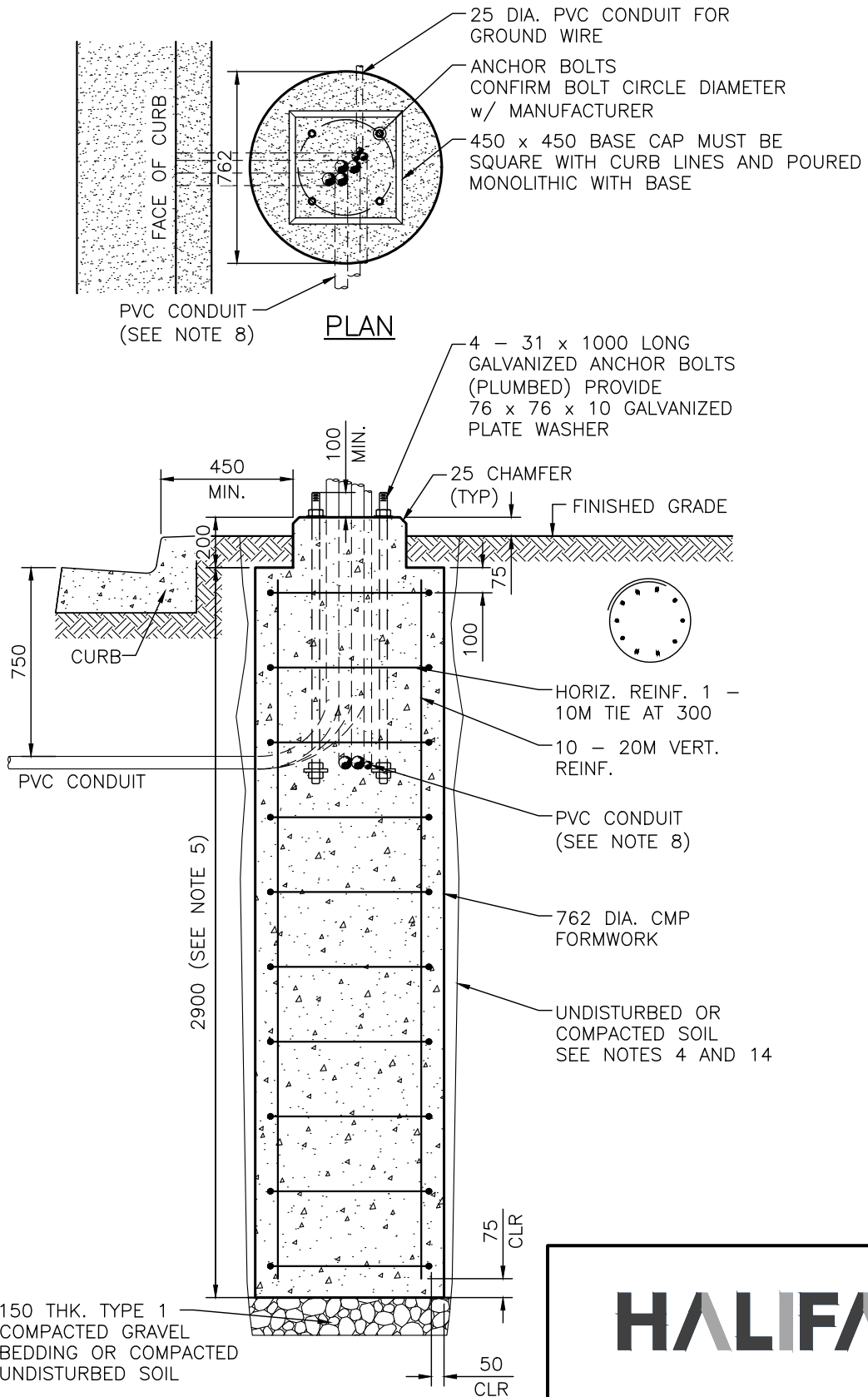

NOTES:

1. SEE HRM 68N3, SELECTION GUIDE, FOR PERMITTED POLES AND TRAFFIC SIGNAL EQUIPMENT.
2. FOR NOTES REFER TO HRM 68N1.
3. DIMENSIONS ARE IN MILLIMETRES.

| | | |
|--|-----------|----------------------------|
| <h1 style="margin: 0;">HALIFAX</h1> | | |
| STANDARD DETAIL | | |
| TRAFFIC SIGNAL BASE FOR CONFIGURATION M | | |
| DATE: 2021 | REFERENCE | APPROVED |
| SCALE: 1:25 | | FIG No.: HRM 71A |

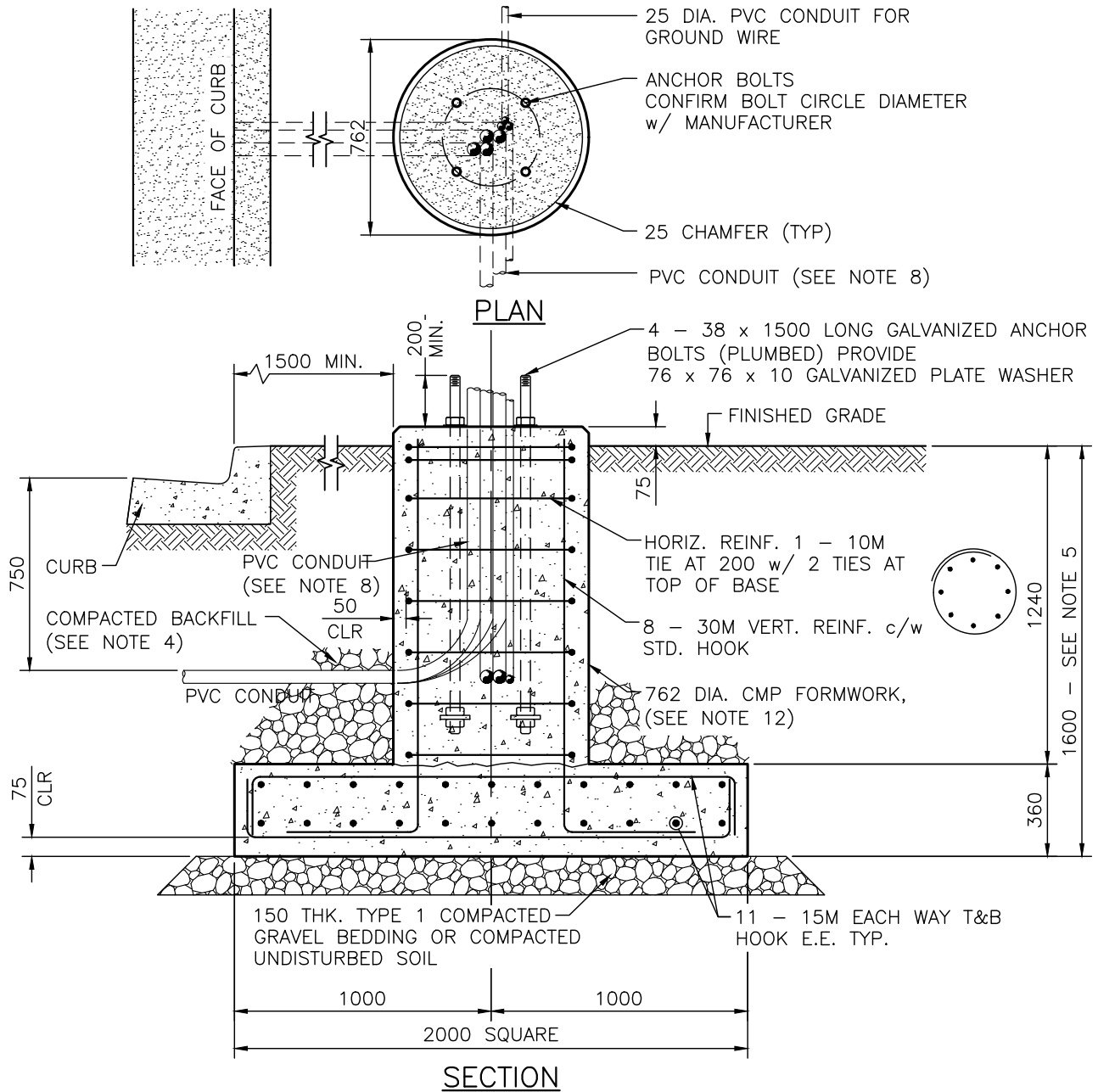

NOTES:

1. SEE HRM 68N3, SELECTION GUIDE, FOR PERMITTED POLES AND TRAFFIC SIGNAL EQUIPMENT.
2. FOR NOTES REFER TO HRM 68N2.
3. DIMENSIONS ARE IN MILLIMETRES.

HALIFAX

STANDARD DETAIL

TRAFFIC SIGNAL BASE FOR CONFIGURATION N, O AND P

| | | | |
|--------|------|-----------|---------------------------|
| DATE: | 2021 | REFERENCE | APPROVED |
| SCALE: | 1:25 | | FIG No.: HRM 72 |

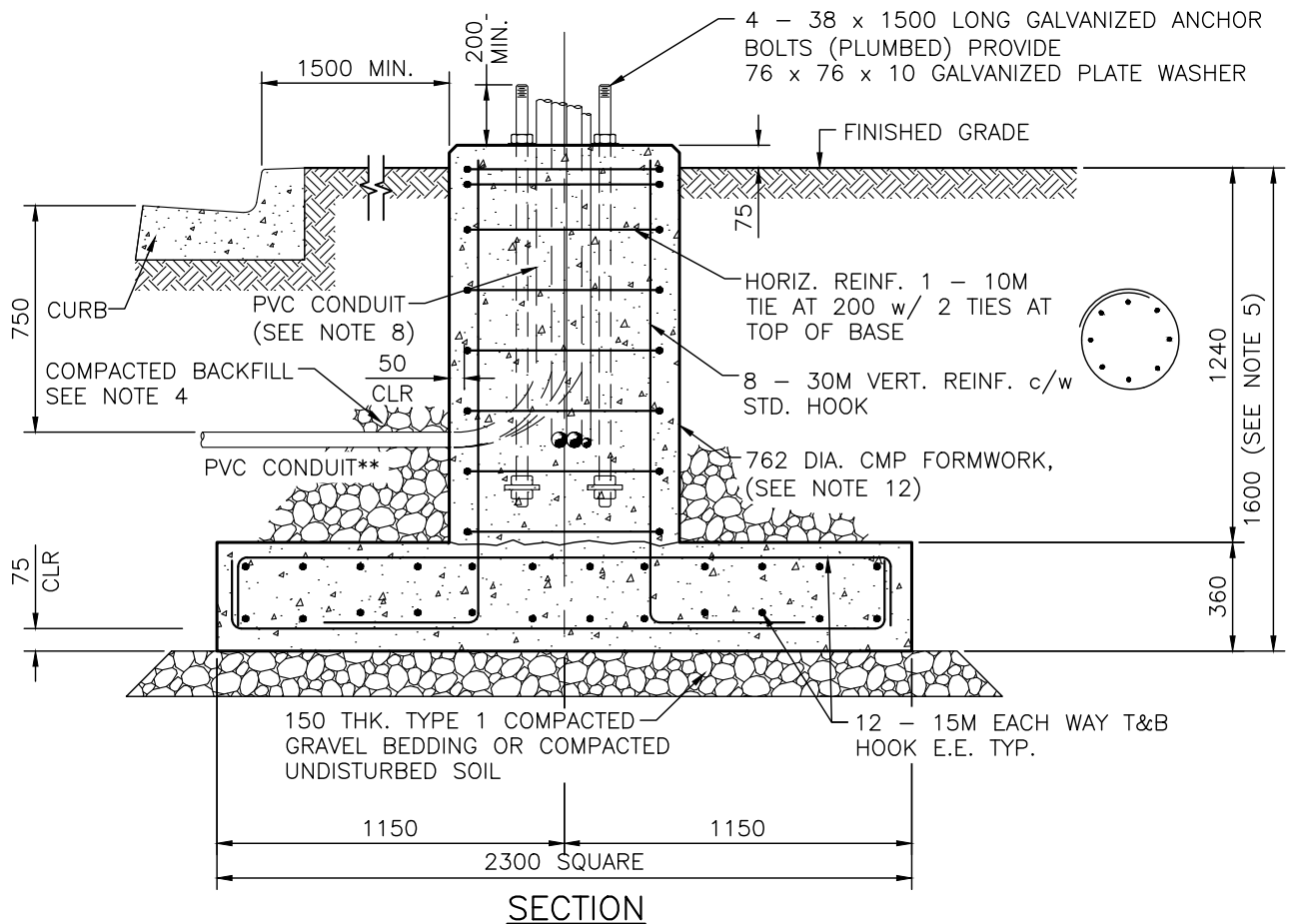
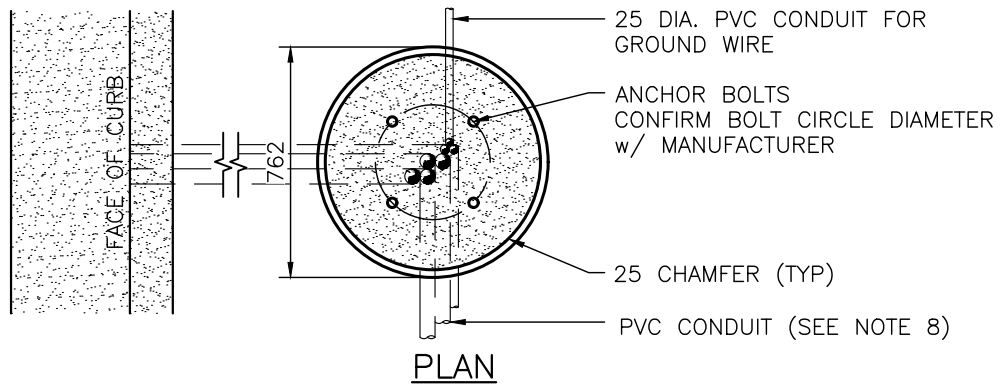

NOTES:

1. SEE HRM 68N3, SELECTION GUIDE, FOR PERMITTED POLES AND TRAFFIC SIGNAL EQUIPMENT.
2. FOR NOTES REFER TO HRM 68N2.
3. DIMENSIONS ARE IN MILLIMETRES.

HALIFAX

STANDARD DETAIL

TRAFFIC SIGNAL BASE FOR CONFIGURATION Q, R AND S

| | | | |
|--------|------|-----------|----------------------------|
| DATE: | 2021 | REFERENCE | APPROVED |
| SCALE: | 1:25 | | FIG No.: HRM 72A |

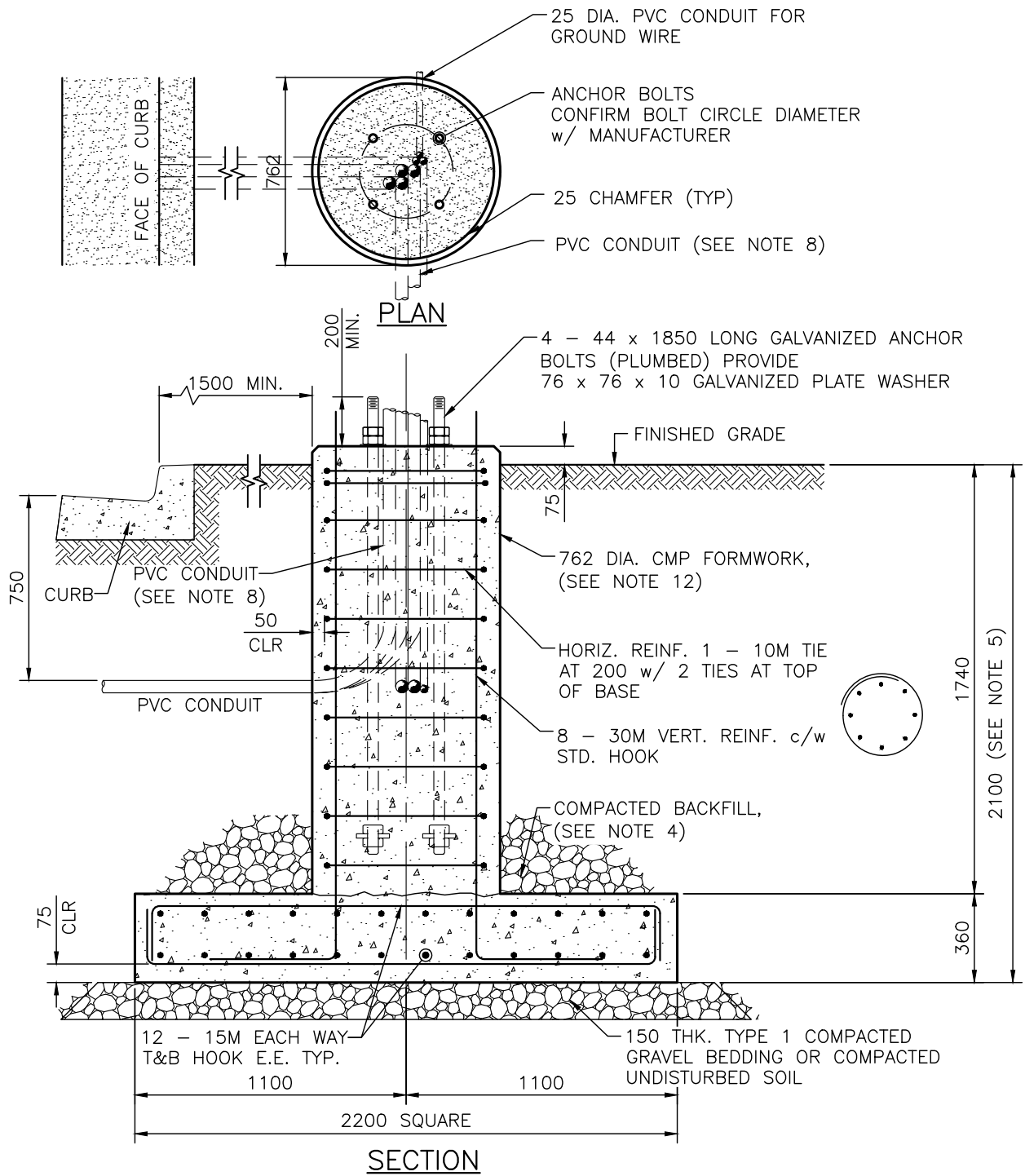

NOTES:

1. SEE HRM 68N3, SELECTION GUIDE, FOR PERMITTED POLES AND TRAFFIC SIGNAL EQUIPMENT.
2. FOR NOTES REFER TO HRM 68N2.
3. DIMENSIONS ARE IN MILLIMETRES.

| | | |
|--|-----------|----------|
| HALIFAX | | |
| STANDARD DETAIL | | |
| TRAFFIC SIGNAL BASE FOR CONFIGURATION T, U AND V | | |
| DATE: | REFERENCE | APPROVED |
| 2021 | | |
| SCALE: | | FIG No.: |
| 1:25 | | HRM 73 |

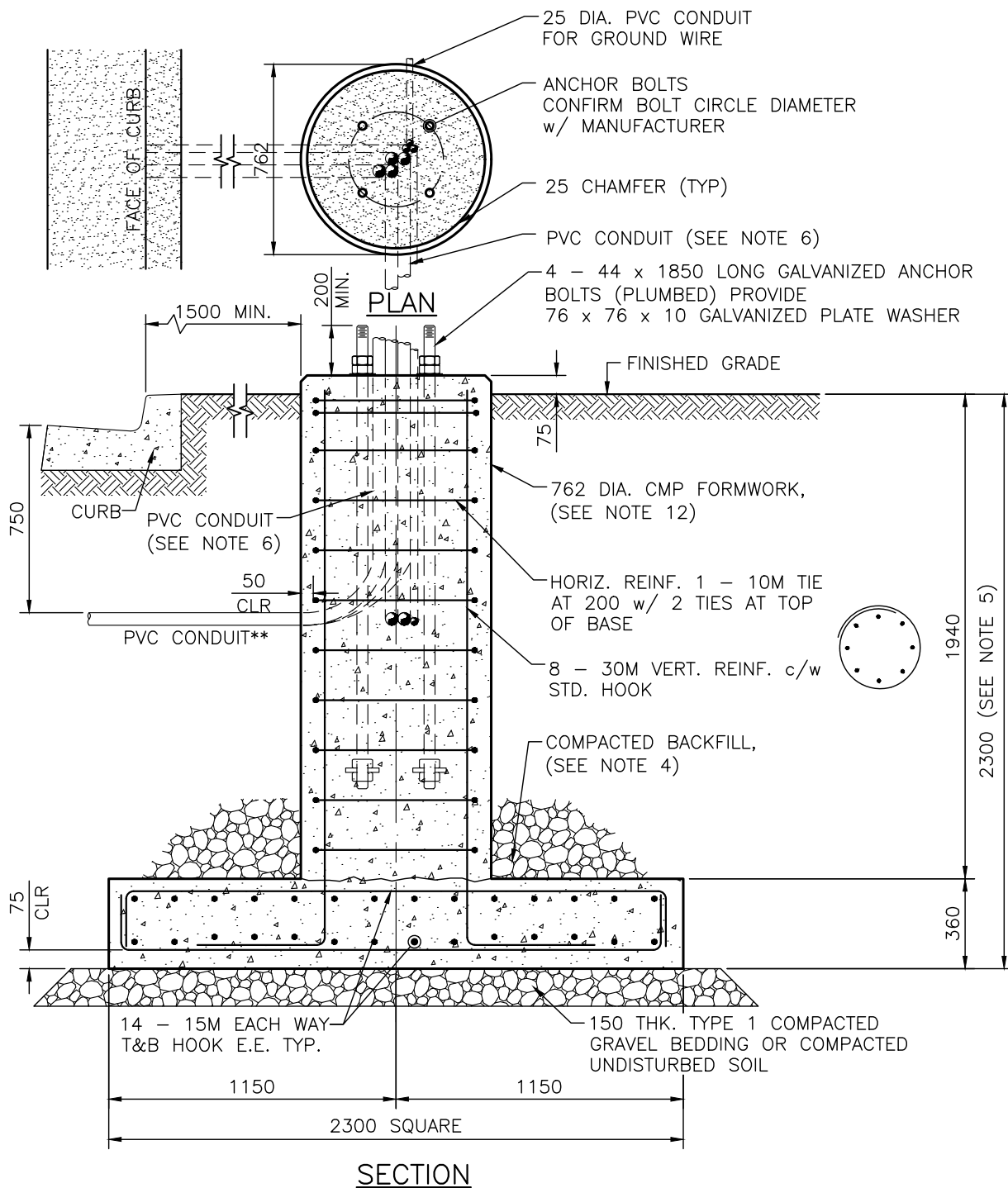

NOTES:

- SEE HRM 68N3, SELECTION GUIDE, FOR PERMITTED POLES AND TRAFFIC SIGNAL EQUIPMENT.
- FOR NOTES REFER TO HRM 68N2.
- DIMENSIONS ARE IN MILLIMETRES.

| | | |
|---|------|----------------------------|
| <h1>HALIFAX</h1> | | |
| STANDARD DETAIL | | |
| TRAFFIC SIGNAL BASE FOR CONFIGURATION W, X AND Y | | |
| DATE: | 2021 | REFERENCE |
| SCALE: | 1:25 | APPROVED |
| | | FIG No.: HRM 73A |

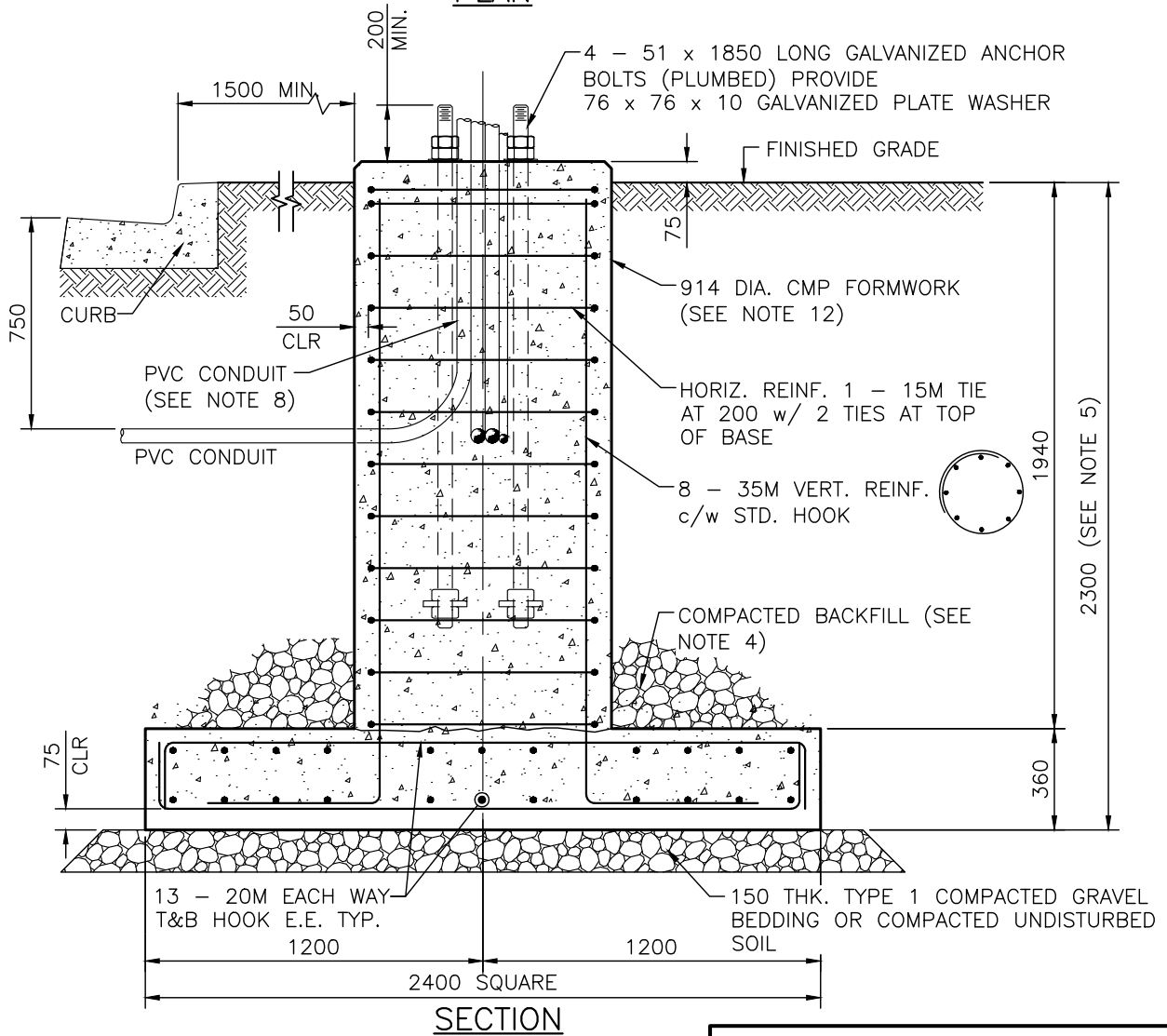
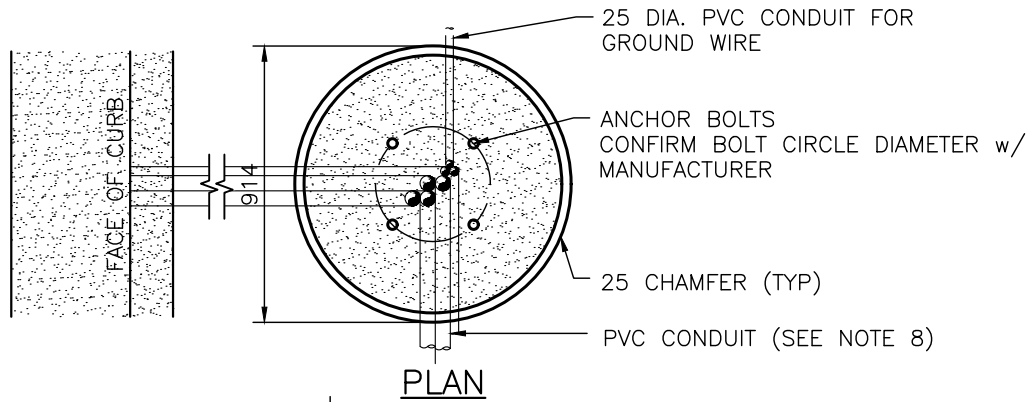

NOTES:

1. SEE HRM 68N3, SELECTION GUIDE, FOR PERMITTED POLES AND TRAFFIC SIGNAL EQUIPMENT.
2. FOR NOTES REFER TO HRM 68N2.
3. DIMENSIONS ARE IN MILLIMETRES.

HALIFAX

STANDARD DETAIL

TRAFFIC SIGNAL BASE FOR CONFIGURATION Z, AA AND AB

| | | | |
|--------|------|-----------|---------------------------|
| DATE: | 2021 | REFERENCE | APPROVED |
| SCALE: | 1:25 | | FIG No.: HRM 74 |

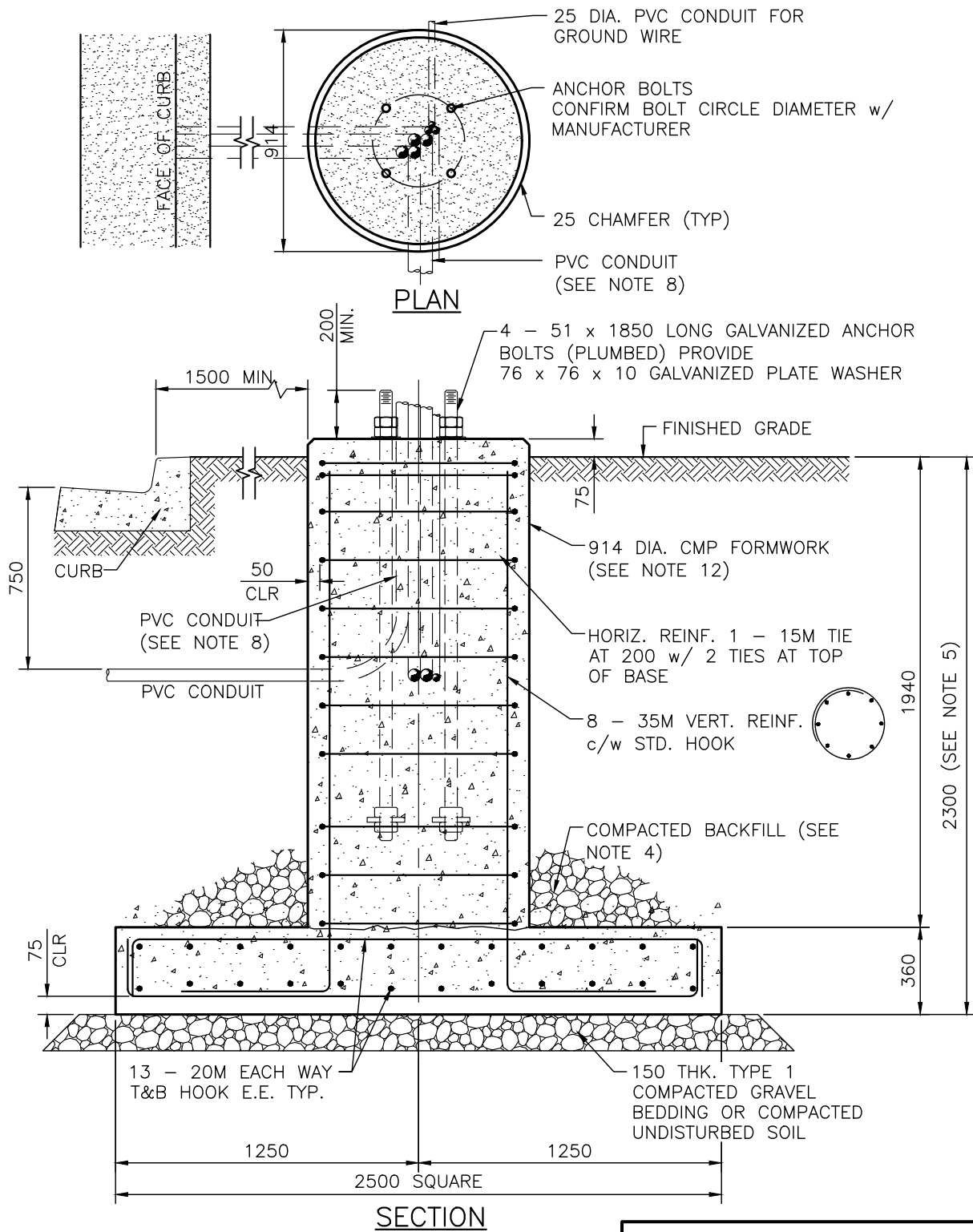

NOTES:

1. SEE HRM 68N3, SELECTION GUIDE, FOR PERMITTED POLES AND TRAFFIC SIGNAL EQUIPMENT.
2. FOR NOTES REFER TO HRM 68N2.
3. DIMENSIONS ARE IN MILLIMETRES.

| | | |
|---|-----------|----------|
| HALIFAX | | |
| STANDARD DETAIL | | |
| TRAFFIC SIGNAL BASE FOR CONFIGURATION AC, AD AND AE | | |
| DATE: | REFERENCE | APPROVED |
| 2021 | | |
| SCALE: | | FIG No.: |
| 1:25 | | HRM 74A |

DOWELS PLACED AT 90 DEG.

ANCHOR BOLTS (TYP.)

DOWELS PLACED AT 60 DEG.

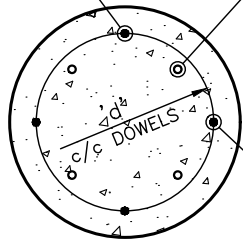

DOWELS (TYP.) DESIGN BASED ON COVER TO DOWELS = 80

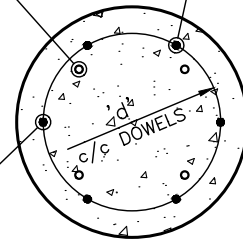

SECTION 4 DOWELS

SECTION 6 DOWELS

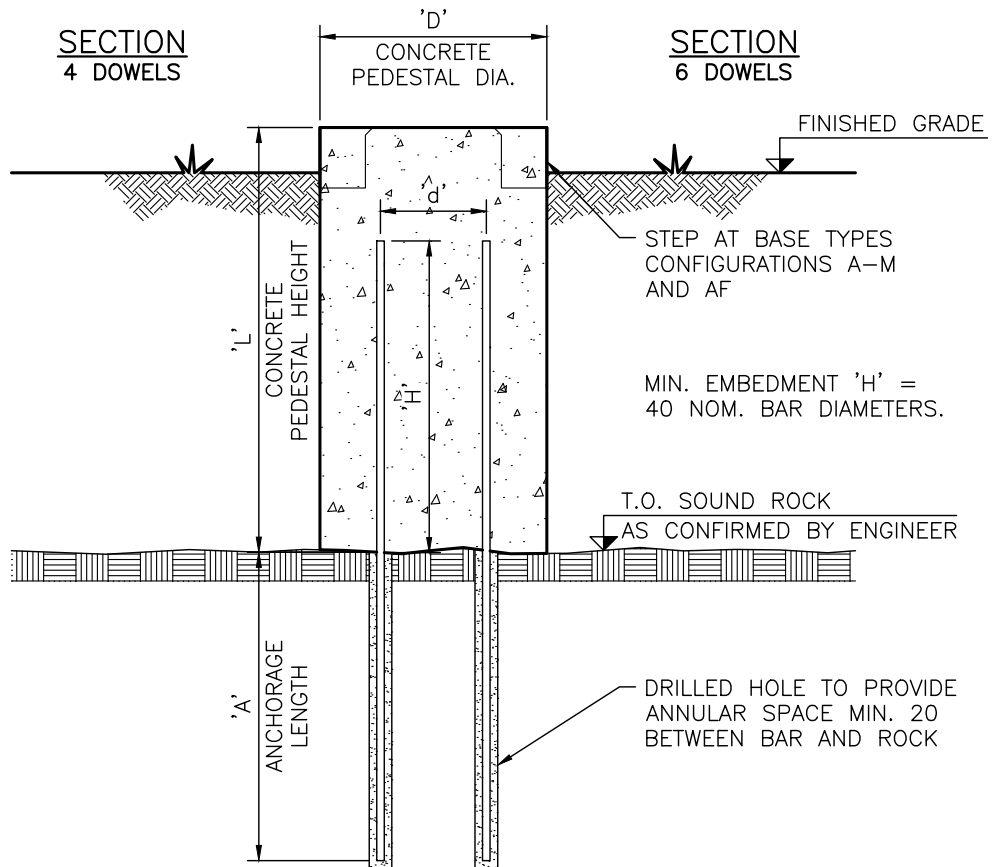

NOTE:

1. SEE HRM 74B.2 FOR ANCHORAGE DETAILS.
2. PEDESTAL REINFORCING NOT SHOWN FOR CLARITY.
3. ANCHOR BOLTS TO BE DESIGNED BY AND STAMPED BY AN ENGINEER LICENSED TO PRACTICE IN NS.

HALIFAX

STANDARD DETAIL

FOUNDATION REVISIONS FOR DOWELING INTO ROCK

| | | | |
|--------|------|-----------|------------------------------|
| DATE: | 2021 | REFERENCE | APPROVED |
| SCALE: | 1:25 | | FIG No.: HRM 74B.1 |

ANCHORAGE SCHEDULE

| REF. DWG. | 'L' MIN. | 'D' | 'd' | 'A' MIN | DOWELS |
|-------------|-------------|-----|-----|------------|---------|
| 68 | 1200 | 610 | 425 | 2500 | 4 – 25M |
| 69 | 1200 | 760 | 575 | 2500 | 4 – 25M |
| 70, 71, 71A | 1300 | 760 | 570 | 3000 | 4 – 30M |
| 72, 72A | 1500 | 760 | 565 | 3500 | 4 – 35M |
| 73, 73A | 1800 | 760 | 565 | 3500 | 6 – 35M |
| 74, 74A | 1800 | 910 | 715 | 4000 | 6 – 35M |
| 74X | 1300 | 760 | 570 | 3000 | 4 – 30M |

NOTES:

1. SOUND ROCK TO BE CONFIRMED BY ENGINEER.
2. MIN. LENGTH 'L' IS REQUIRED TO SUIT LENGTH OF ANCHOR BOLTS.
3. DRILLED HOLE IN ROCK TO BE CLEAN AND DRY BEFORE GROUTING. GROUT TO BE MASTERFLOW 816 CABLE GROUT OR APPROVED EQUAL, INSTALLED IN ACCORDANCE WITH MANUFACTURER'S DIRECTIONS.
4. THIS DRAWING TO BE USED IN CONJUNCTION WITH HRM 74B.1.
5. ANCHOR BOLTS TO BE DESIGNED BY AND STAMPED BY AN ENGINEER LICENSED TO PRACTICE IN NS.

HALIFAX

STANDARD DETAIL

**FOUNDATION REVISIONS
FOR DOWELING INTO ROCK**

| | | | |
|--------|------|-----------|------------------------------|
| DATE: | 2021 | REFERENCE | APPROVED |
| SCALE: | NTS | | FIG No.: HRM 74B.2 |

25 DIA. PVC CONDUIT**
FOR GROUND WIRE

ANCHOR BOLTS
CONFIRM BOLT CIRCLE DIAMETER w/
MANUFACTURER

450 x 450 (OR 500 x 500) BASE
CAP MUST BE SQUARE WITH CURB
LINES AND POURED MONOLITHIC WITH
BASE

53 DIA. PVC CONDUIT (SEE NOTE 8)

SPARE 53 DIA. PVC
CONDUIT** (CAPPED)

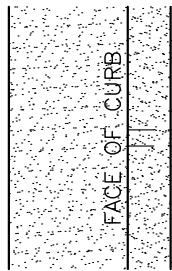

PLAN

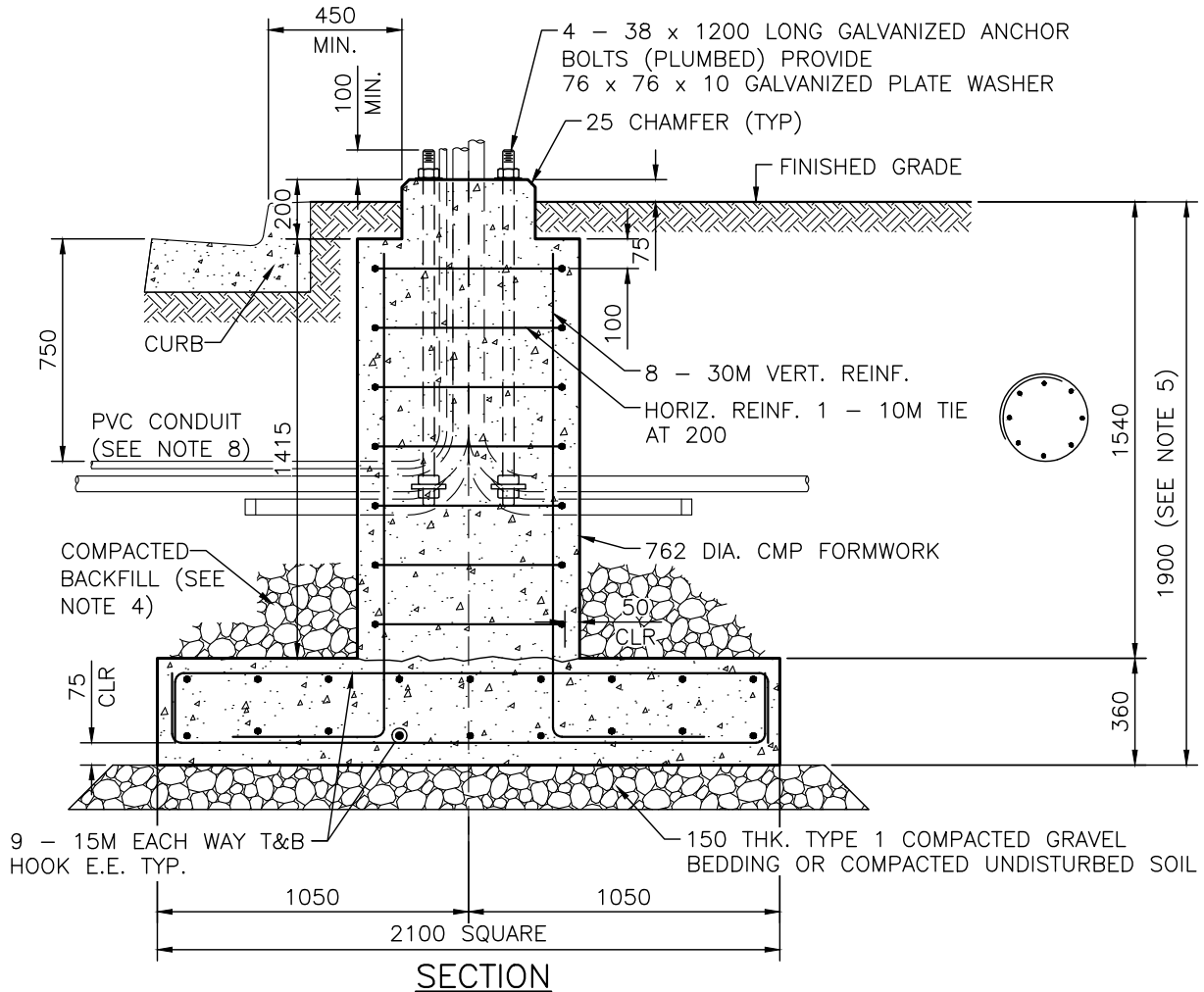

SECTION

NOTES:

1. SEE HRM 68N3, SELECTION GUIDE, FOR PERMITTED POLES AND TRAFFIC SIGNAL EQUIPMENT.
2. FOR NOTES REFER TO HRM 68N2.
3. DIMENSIONS ARE IN MILLIMETRES.

HALIFAX

STANDARD DETAIL

TRAFFIC SIGNAL BASE
FOR CONFIGURATION AF

| | | | |
|--------|------|-----------|----------------------------|
| DATE: | 2021 | REFERENCE | APPROVED |
| SCALE: | 1:25 | | FIG No.: HRM 74X |

NOTES:

1. CONCRETE 28 DAY COMPRESSIVE STRENGTH TO BE 35 MPa.
2. PROVIDE MIN. 50 COVER FOR ALL REBAR (UNLESS NOTED OTHERWISE).
3. PROVIDE GROUNDING FOR CONTROLLER CABINET.
4. IN ADDITION TO CONDUITS SPECIFIED ON EQUIPMENT DRAWINGS/SPECIFICATIONS, PROVIDE 2-50mm DIA. PVC CONDUIT AND GROUNDING CONDUIT FOR CONNECTION BETWEEN EQUIPMENT CHIMNEYS.
5. ALL CONDUIT FITTINGS SHALL BE TO CANADIAN ELECTRICAL CODE.
6. CONTROLLER CABINET ANCHORS ARE ASSUMED TO BE 20mm DIA. x 150mm LONG A304 STAINLESS STEEL THREADED ROD, WITH APPROVED CHEMICAL ADHESIVE, INSTALLED IN ACCORDANCE WITH ANCHOR MANUFACTURERS GUIDELINES.
7. BATTERY BACK-UP UNIT ANCHORS ARE ASSUMED TO BE 22mm DIA. x 150mm LONG A304 STAINLESS STEEL THREADED ROD, WITH APPROVED CHEMICAL ADHESIVE, INSTALLED IN ACCORDANCE WITH ANCHOR MANUFACTURERS GUIDELINES.
8. SUITABILITY OF ANCHORS IS TO BE CONFIRMED BY EQUIPMENT MANUFACTURER PRIOR TO INSTALLATION.
9. MAXIMIZE ANCHOR EDGE DISTANCES.
10. ALL DIMENSIONS IN MILLIMETERS.
11. REBAR TO CONFORM TO CAN/CSA G30.18-09 GRADE 400W DEFORMED BARS.

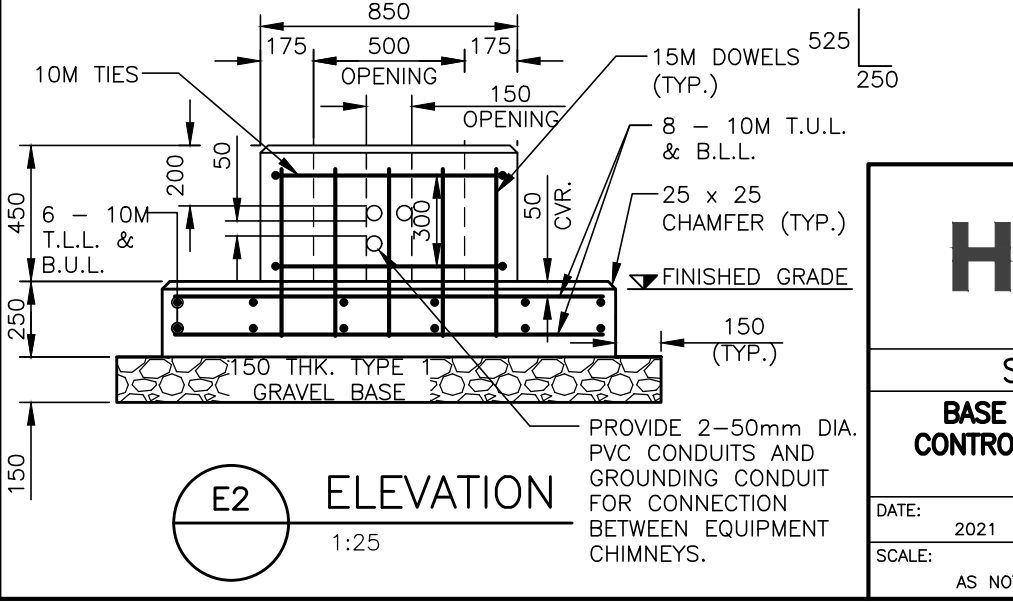
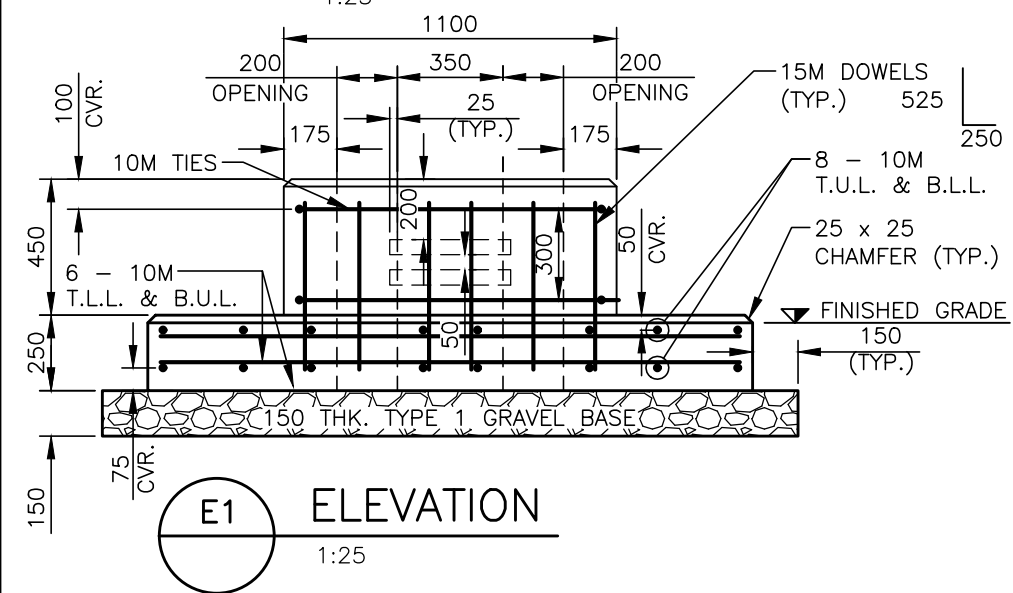
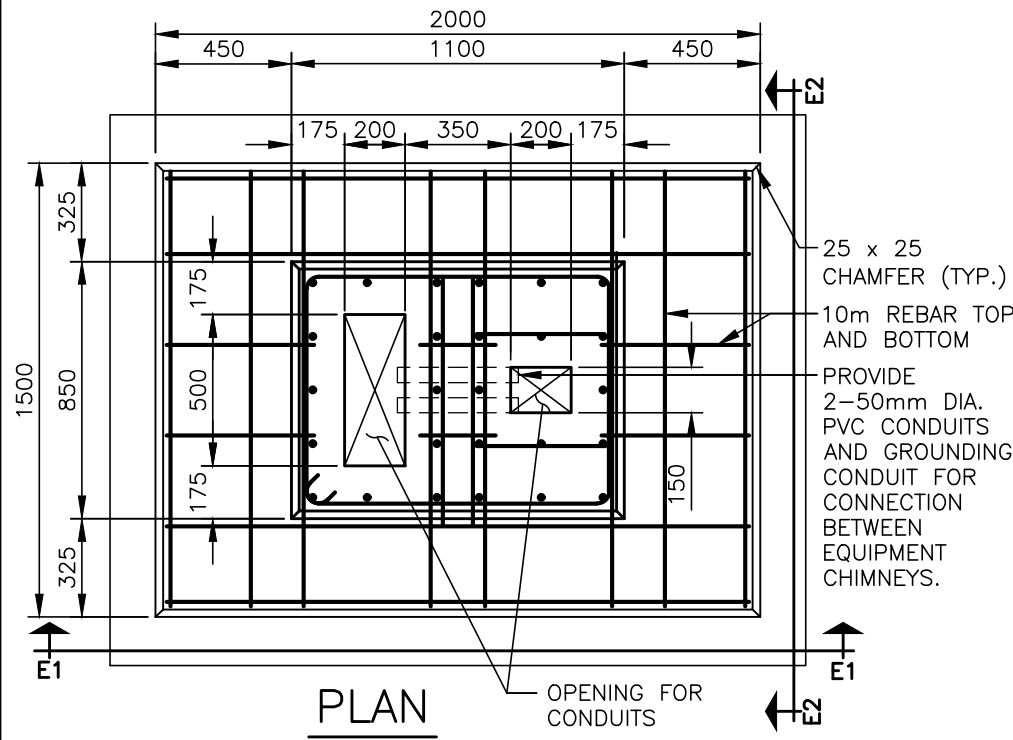

HALIFAX

STANDARD DETAIL

BASE MOUNTED TRAFFIC SIGNAL CONTROLLER CABINET WITH BATTERY BACK-UP UNIT

| | | |
|----------|-----------|----------|
| DATE: | REFERENCE | APPROVED |
| 2021 | | |
| SCALE: | | FIG No.: |
| AS NOTED | | HRM 176 |

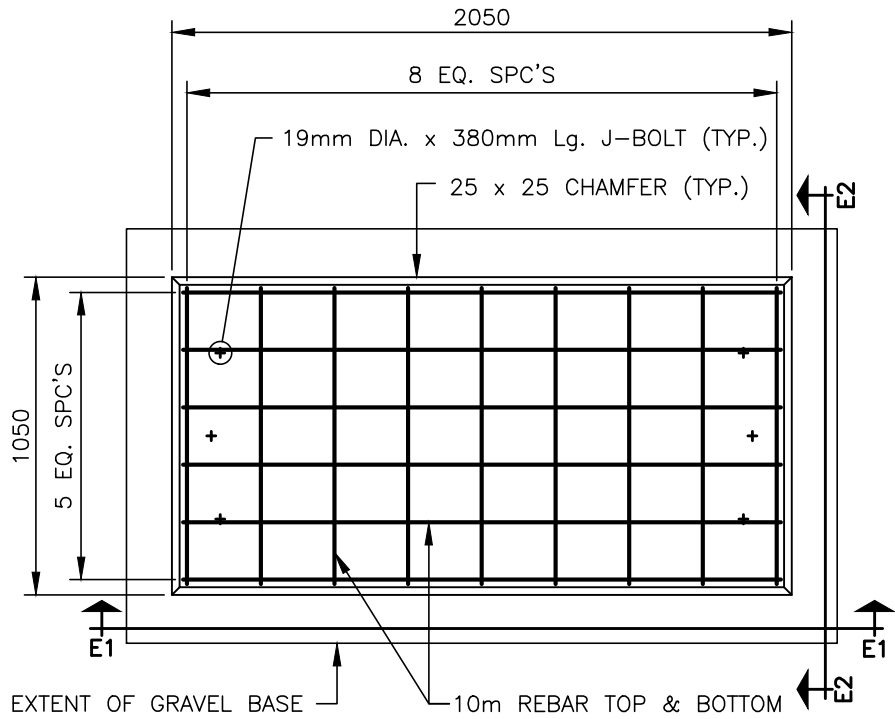

PLAN

1:25

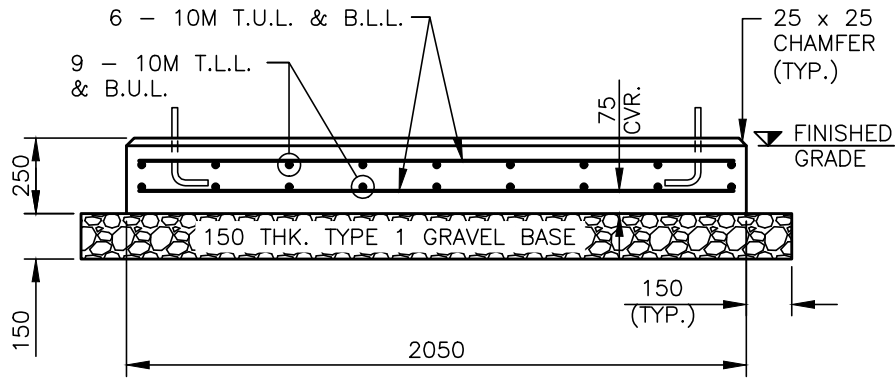

E1 ELEVATION

1:25

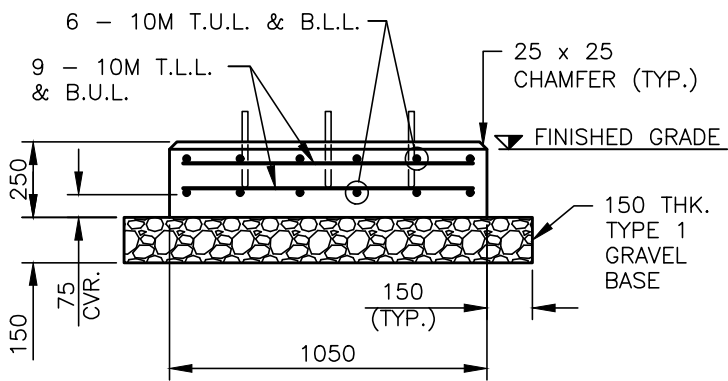

E2 ELEVATION

1:25

NOTES:

1. CONCRETE 28 DAY COMPRESSIVE STRENGTH TO BE 35 MPa.
2. PROVIDE MIN. 50mm COVER FOR ALL REBAR (UNLESS NOTED OTHERWISE).
3. PROVIDE GROUNDING PLATE FOR CABINET.
4. TYPICAL STREET LIGHT POWER ENCLOSURES ARE 610mm WIDE BY 1830mm LONG BY 1830mm HIGH. THE ENCLOSURE MUST BE CENTERED ON THE CONCRETE PAD AND THE CONDUIT LAYOUT MUST ALIGN WITH THE MOUNTING BACKBOARD INSIDE THE ENCLOSURE AS PER THE TYPICAL STREET LIGHT POWER ENCLOSURE "RED BOOK" DETAILS HRM 109-HRM 111.
5. ALL CONDUIT FITTINGS AND GROUNDING SHALL BE TO CANADIAN ELECTRICAL CODE.
6. CONTROLLER CABINET ANCHORS ARE ASSUMED TO BE 6-19mm DIA. x 380mm LONG A307 GALVANIZED STEEL J-BOLTS.
7. SUITABILITY OF ANCHORS IS TO BE CONFIRMED BY EQUIPMENT MANUFACTURER PRIOR TO INSTALLATION.
8. ALL DIMENSIONS IN MILLIMETERS.
9. REBAR TO CONFORM TO CAN/CSA G30.18-09 GRADE 400W DEFORMED BARS.
10. MAXIMUM CONDUIT DIAMETER = 150mm. PROVIDE AT LEAST 25mm CLEAR SPACE BETWEEN CONDUITS.
11. MAXIMUM NUMBER OF CONDUITS PER BASE = 10 x 150mm DIA. CONDUITS OR EQUIVALENT AREA OF SMALLER CONDUITS. (LOCALLY ADJUST REBAR SPACINGS IF NECESSARY).

| | | |
|---|-----------|----------|
| <h1>HALIFAX</h1> | | |
| STANDARD DETAIL | | |
| STREET LIGHTING POWER ENCLOSURE BASE | | |
| DATE: | REFERENCE | APPROVED |
| 2021 | | |
| SCALE: | | FIG No.: |
| AS NOTED | | HRM 177 |

Occupational Health & Safety Policy

The Halifax Regional Municipality is committed to providing a healthy, safe and supportive workplace for its employees, and believes that the physical and psychological well-being and safety of employees are important for accomplishing organizational success and sustainability.

The municipality believes that Occupational Health & Safety (OHS) is the direct responsibility of all employees to the extent of each person's authority and ability to act. Therefore, the municipality supports the Internal Responsibility System (IRS) framework and is committed to working collaboratively with employees, their representatives, and Joint Occupational Health & Safety Committees to realize an effective Occupational Health & Safety Program (OHS Program). To this end:

- The municipality shall actively seek and consider input of the diverse perspectives and needs of employees with respect to the OHS Program, Corporate Procedures and Safe Work Practices;
- All municipal employees and volunteers are accountable for creating safe work environments and adhering to safe work practices, and are accountable for reporting all unsafe acts, hazards and conditions;
- The municipality shall cooperate with the Joint Occupational Health & Safety Committees and any safety representatives;
- The municipality holds all levels of management responsible and accountable for implementation and enforcement of this Policy, the OHS Program, the development and implementation of job-specific safe work practices, and for ensuring compliance with the *Nova Scotia Occupational Health & Safety Act* (OHSA) and applicable regulations;
- The municipality ensures health and safety considerations are integrated into the daily planning and execution of work, and maintenance of tools, machinery, facilities and equipment;
- The municipality takes every reasonable precaution to eliminate any foreseeable hazards in municipal workplaces that may result in personal injury or illness;
- The municipality recognizes that violence in the workplace is an occupational health and safety hazard that may result in physical and/or emotional harm. Any form of violence is unacceptable, and the municipality is committed to minimizing/eliminating the risk of violence. The municipality will not tolerate any act of violence committed by or against employees, contractors, suppliers, volunteers or other persons present at Halifax Regional Municipality workplaces;
- Outside contractors, suppliers and volunteers are to be informed of this Policy, sections of the OHS Program, any job specific safe work procedures that impact them, and will be held responsible for complying with those requirements along with any other requirements under the OHSA and applicable regulations.

Original Signed

Jacques Dubé, Chief Administrative Officer

March 30, 2021