

Municipal Design Guidelines

2021

Part B: Standard Details



HALIFAX

Part B: Standard Details

Contents

HRM 1	Pavement Structure
HRM 2	Regional Centre Residential / Suburban Residential (Local)
HRM 3	Regional Centre Residential (Minor Collector)
HRM 4	Regional Centre Residential (Major Collector)
HRM 5	Regional Centre Commercial / Mixed Use (Local)
HRM 6	Regional Centre Commercial / Mixed Use (Minor Collector)
HRM 7	Regional Centre Commercial / Mixed Use (Major Collector)
HRM 8	Regional Centre Commercial / Mixed Use (Arterial)
HRM 9	Suburban (Minor Collector)
HRM 10	Suburban (Major Collector)
HRM 11	Suburban (Arterial)
HRM 12	Rural (Local)
HRM 13	Rural (Minor Collector)
HRM 14	Rural (Major Collector)
HRM 15	Urban Local Cul-de-Sac
HRM 16	Urban Industrial Cul-de-Sac
HRM 17	Rural (Arterial)
HRM 18	Industrial (Local)
HRM 19	Industrial (Minor Collector)
HRM 20	Industrial (Major Collector)
HRM 21	Industrial (Arterial)
HRM 22	<i>Retired Detail – 30.0 m Rural Major Collector with Turning Lane</i>
HRM 23	<i>Retired Detail – 25.0 m Rural Arterial</i>
HRM 24	<i>Retired Detail – 40.0 m Rural Arterial</i>
HRM 25	<i>Retired Detail – 40.0 m Rural Arterial with Turning Lane</i>

HRM 26	<i>Retired Detail – 23.0 m Rural Industrial</i>
HRM 27	Rural Local Cul-de-Sac
HRM 28	Rural Industrial Cul-de-Sac
HRM 29	Glass Grid Installation
HRM 30	Asphalt Swale
HRM 31	Speed Hump
HRM 32	Driveway Deflection Angles & Grades
HRM 33	Community Mailbox – Urban Road Without Sidewalk
HRM 34	Community Mailbox – Urban Road with Sidewalk
HRM 35	Community Mailbox – Rural Road Layby
HRM 36	Guide Rail Installation
HRM 37	Railing
HRM 38	Urban Traffic Sign Post
HRM 39	Rural Traffic Sign Post
HRM 40	Typical Walkway
HRM 41	Active Transportation Off Road Trail
HRM 42	Chain Link Fence
HRM 43	Page Wire Fence
HRM 44	Urban Sidewalk
HRM 45	Rural Type 1 Sidewalk
HRM 46	Rural Type II Sidewalk
HRM 47	Rural Type III Sidewalk
HRM 48	Concrete Sidewalk Reinforcing
HRM 49	Pedestrian Ramp Alignment
HRM 50	Driveway Ramp
HRM 51	Driveway Access in Existing Full-Depth Curb
HRM 52	Concrete Traffic Island
HRM 53	Concrete Curb & Gutter

HRM 54	Curb Renewal/Payment
HRM 55	Asphalt Curb
HRM 56	Concrete Bus Stop Landing Pad
HRM 57	Concrete Bus Bay Pad - End Block
HRM 58	Concrete Bus Bay Pad - Mid Block
HRM 59	Shallow Trench Reinstatement
HRM 60	Deep Trench Reinstatement
HRM 61	Trench Backfill and Reinstatement – Testing
HRM 62	<i>Retired Detail – Pre-Fabricated Tree Collar</i>
HRM 63	<i>Retired Detail – Floating Sidewalk</i>
HRM 64	<i>Retired Detail – Paver Pattern</i>
HRM 65	<i>Retired Detail – Tree Vault</i>
HRM 66	Tree Planting in Parks / Open Space
HRM 67	Shrub Planting
HRM 68	Traffic Signal Base for Configuration A
HRM 68N1	Standard Notes Shaft Foundations
HRM 68N2	Standard Notes Spread Footings
HRM 68N3	Pole Base Selection Guide
HRM 69	Traffic Signal Base or Configuration B, C, D, and E
HRM 70	Traffic Signal Base for Configuration F, G and H
HRM 71	Traffic Signal Base for Configuration I, J, K and L
HRM 71A	Traffic Signal Base for Configuration M
HRM 72	Traffic Signal Base for Configuration N, O and P
HRM 72A	Traffic Signal Base for Configuration Q, R and S
HRM 73	Traffic Signal Base for Configuration T, U and V
HRM 73A	Traffic Signal Base for Configuration W, X and Y
HRM 74	Traffic Signal Base for Configuration Z, AA and AB
HRM 74A	Traffic Signal Base for Configuration AC, AD and AE

HRM 74B.1	Foundation Revisions for Doweling into Rock
HRM 74B.2	Foundation Revisions for Dowling into Rock
HRM 74X	Traffic Signal Base for Configuration AF
HRM 75	Pedestrian & Cyclist Push Button Pole & Base
HRM 76	Base Mounted Traffic Signal Controller Cabinet
HRM 77	<i>Retired Detail – Base Mounted Traffic Signal Controller Cabinet with Battery Backup Unit</i>
HRM 78	Underground Conduit
HRM 79	Pull Pit
HRM 80	Junction Box Type “A”
HRM 81	Junction Box Type “B” & “C”
HRM 82	Detector Loop Saw Cut
HRM 83	Pre-Formed Detector Loop
HRM 84	Pole Mount Details for Detector Loop Installation
HRM 85	Pole Mount Home Run
HRM 86	Wooden Pole Power Feed (for Traffic Signals)
HRM 87	Aluminium Pole RA-5 Signal Configuration
HRM 88	Wooden Pole RA-5 Traffic Signal with Power Feed Configuration
HRM 89	Standard Intersection Pavement Marking Layout
HRM 90	Longitudinal and Transverse Pavement Markings
HRM 91	Pavement Arrows
HRM 92	Bicycle Symbol and Shared Use Lane Symbol
HRM 93	Pedestrian & Trail Crossing Pavement Markings
HRM 94	Standard Roundabout Pavement Marking Layout
HRM 95	Roundabout Pavement Arrows
HRM 96	Special Pavement Markings
HRM 97	Typical Cobrahead-LED on a Davit Arm
HRM 98	Davit Arm – 600 mm

HRM 99	Davit Arm – 1800 mm
HRM 100	Elliptical Davit Arm – 1800 mm
HRM 101	Elliptical Davit Arm – 3000 mm
HRM 102	Elliptical Davit Arm – 3600 mm
HRM 103	Aluminium Lighting Standard – 7.7 m
HRM 104	Aluminium Lighting Standard – 9.7 m
HRM 105	Aluminium Lighting Standard – 12.2 m
HRM 106	Aluminium Double Davit Lighting Standard – 9.7 m
HRM 107	Aluminium Double Davit Lighting Standard – 12.2 m
HRM 108	Relay Installation
HRM 109	Street Light Power Enclosure
HRM 110	Street Light Power Enclosure Diagram
HRM 111	Street Light Power Enclosure Layout
HRM 112	Street Lighting Underground Electrical Service
HRM 113	Street Lighting Underground Electrical Service
HRM 114	Street Lighting Underground Electrical Service
HRM 115	347 Volt 3 Phase Underground Service Over 154 Amps
HRM 116	Ornamental Street Light Base
HRM 117	Standard Aluminium Street Light Base Type 2
HRM 118	Wooden Fence
HRM 119	Pedestrian Gate
HRM 120	Bollard
HRM 121	Bollard - Removable
HRM 122	Survey Monument
HRM 123	<i>Retired Detail – Survey Monument Cover and Frame</i>
HRM 124	Survey Monument Type I
HRM 125	Survey Monument Type II
HRM 126	<i>Retired Detail – Parking Meter Standard Unit and Base</i>

HRM 126A	Parking Pay Station Base (Typical)
HRM 126B	Parking Pay Station Base on Existing Green Boulevard
HRM 126C	Parking Pay Station Base on Existing Sidewalk
HRM 127	Core Boundary
HRM 128	<i>Retired Detail – Capital District</i>
HRM 129	<i>Missing Intentionally</i>
HRM 130	<i>Missing Intentionally</i>
HRM 131	Tactile Walking Surface Indicator Ramp Placement
HRM 132	Walkway with Pedestrian Ramp
HRM 133	Concrete Sidewalk Adjacent Curb
HRM 134	Red In-Lay Reserved Lane
HRM 135	Fence Detail (Round Wooden Rails & Steel Posts)
HRM 136	Speed Hump Survey Verification
HRM 137	Concrete Bus Stop Landing Pad (Without Sidewalk)
HRM 138	Concrete Bus Stop Landing Pad (With Sidewalk)
HRM 139	Concrete Bus Stop Landing Pad (Without Curb)
HRM 140	Tree Protection Zone & Barrier
HRM 141	Decorative Paving Edge
HRM 142	Narrow Decorative Paving Edge
HRM 143	Speed Table Detail
HRM 144	Speed Table Survey Verification
HRM 145	240 Volt Under 20 Amps Service with GCFI
HRM 146	Service Contactor and Schematic
HRM 147	Pole Electrical Details
HRM 148	120 240 Volt Stub Pole Service with GFCI's
HRM 149	Traffic Signal Streetlight Combination Pole
HRM 150	Power Enclosure Concrete Pad Top View
HRM 151	Transformer Base Grounding-Model

HRM 152	Typical Relay Installation
HRM 153	Bus Stop Shelter on Concrete Sidewalk
HRM 154	Stand Alone Concrete Bus Stop Pad
HRM 155	Bus Stop Shelter on Concrete Wall
HRM 156	Bus Stop Shelter on Concrete Sono-Tubes
HRM 157	<i>Missing Intentionally</i>
HRM 158	<i>Missing Intentionally</i>
HRM 159	<i>Missing Intentionally</i>
HRM 160	Utility Pole Service Detail
HRM 161	<i>Missing Intentionally</i>
HRM 162	<i>Missing Intentionally</i>
HRM 163	<i>Missing Intentionally</i>
HRM 164	<i>Missing Intentionally</i>
HRM 165	Inverted U Bike Rack
HRM 166	Multi Inverted U Bike Rack
HRM 167	Post & Ring Bike Rack
HRM 168	<i>Missing Intentionally</i>
HRM 169	Back in Angle Parking 60° and 45°
HRM 170	Street Light Power Enclosure Single Line Diagram
HRM 171	Street Light Power Enclosure Parts List
HRM 172	Rectangular Rapid-Flashing Beacon Signal Configuration (Solar Panel)
HRM 173	<i>Missing Intentionally</i>
HRM 174	<i>Missing Intentionally</i>
HRM 175	Base Mounted Traffic Signal Controller Cabinet
HRM 176	Base Mounted Traffic Signal Controller Cabinet with Battery Back-up Unit
HRM 177	Street Lighting Power Enclosure Base
HRM 178	<i>Missing Intentionally</i>
HRM 179	<i>Missing Intentionally</i>

HRM 180	Rectangular Rapid-Flashing Beacon Signal Configuration (Solar Engine)
HRM 181	Soil Texture Triangle
HRM 182	Tree Planting in Sod Boulevard
HRM 183	RA-5 Crossing
HRM 184	RA-5 Crossing (With Centre Median)
HRM 185	<i>Missing Intentionally</i>
HRM 186	Tree in Hardscape with Soil Cells and Tree Grate
HRM 187	Tree Grate Details
HRM 188	Tree in Sod Boulevard with Soil Cells
HRM 189	Bicycle Pavement Markings
HRM 190	Bicycle Lane Conflict Markings

STREET CLASSIFICATION		ASPHALT		ROADBED GRAVELS			
	SUBGRADE TYPE	TOP LIFT	BASE LIFT	GRAVEL TYPE 1	GRAVEL TYPE 2	GRANULAR TILL	ROCK FILL
LOCAL	SILT/CLAY OPTION 1	40 C-HF (NOTE 4)	50 B-HF	150	500	(NOTE 2)	0
	SILT/CLAY OPTION 2	40 C-HF (NOTE 4)	50 B-HF	150	250		400
	GRANULAR TILL	40 C-HF (NOTE 4)	50 B-HF	150	300		0
	ROCK FILL	40 C-HF (NOTE 4)	50 B-HF	150	150		0
LOCAL INDUSTRIAL	SILT/CLAY OPTION 1	50 C-HF	50 B-HF	150	600	(NOTE 2)	0
	SILT/CLAY OPTION 2	50 C-HF	50 C-HF	150	400		500
	GRANULAR TILL	50 C-HF	50 C-HF	150	500		0
	ROCK FILL	50 C-HF	50 C-HF	150	300		0
MINOR COLLECTOR	SILT/CLAY OPTION 1	50 C-HF	75 B-HF	150	600	(NOTE 2)	0
	SILT/CLAY OPTION 2	50 C-HF	75 B-HF	150	350		400
	GRANULAR TILL	50 C-HF	75 B-HF	150	400		0
	ROCK FILL	50 C-HF	75 B-HF	150	300		0
MAJOR COLLECTOR	SILT/CLAY OPTION 1	50 C-HF	75 B-HF	150	600	(NOTE 2)	0
	SILT/CLAY OPTION 2	50 C-HF	75 B-HF	150	350		400
	GRANULAR TILL	50 C-HF	75 B-HF	150	400		0
	ROCK FILL	50 C-HF	75 B-HF	150	300		0
ARTERIAL	SILT/CLAY OPTION 1	50 C-HF	100 B-HF	200	725	(NOTE 2)	0
	SILT/CLAY OPTION 2	50 C-HF	100 B-HF	200	450		500
	GRANULAR TILL	50 C-HF	100 B-HF	200	550		0
	ROCK FILL	50 C-HF	100 B-HF	200	350		0

NOTES:

1. ADDITIONAL ROADBED AND SLOPE STABILIZATION AS REQUIRED BY GEOTECHNICAL REPORT.
2. MINIMUM TYPE 2 GRAVEL THICKNESS, A GEOTECHNICAL REPORT IS REQUIRED TO DETERMINE THE SUBGRADE TYPE FOR THE PAVEMENT STRUCTURE.
3. ASPHALT DESIGN, SPECIFYING TYPE AND THICKNESS OF ASPHALTIC CONCRETE REQUIRED, MAY BE CONSIDERED.
4. MAY BE 40 mm TYPE D-HF OR 40 mm TYPE SPECIAL C-HF.

HALIFAX

STANDARD DETAIL

PAVEMENT STRUCTURE

DATE:	2021	REFERENCE	APPROVED
SCALE:	NTS		FIG No.:

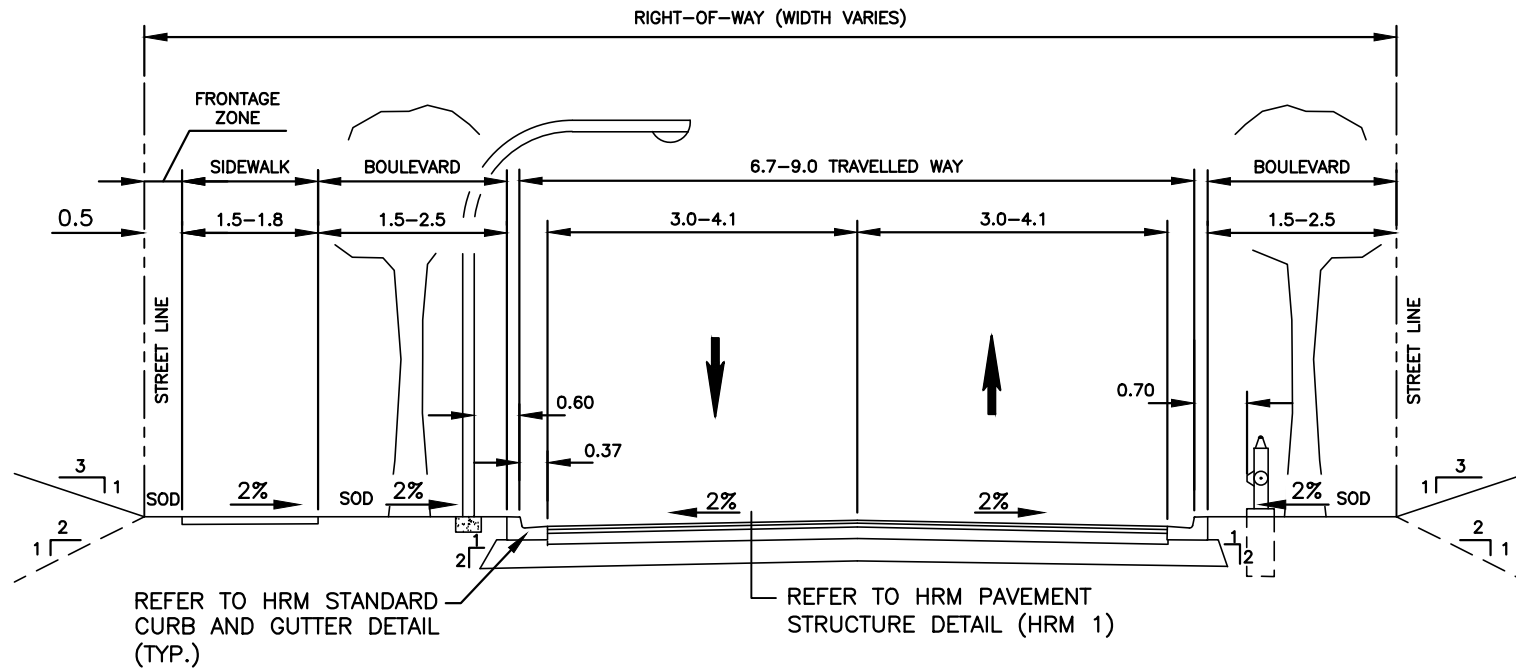

CROSS SECTION

NOTES:

1. SEE SECTION 2.4.2 FOR FURTHER GUIDANCE.
2. LANE WIDTHS DO NOT INCLUDE STANDARD GUTTER WIDTH.
3. BOULEVARD WIDTH OF 1.2 m – 1.5 m MAY BE CONSIDERED IN RETROFIT SITUATIONS, SOIL CELLS MAY BE REQUIRED TO ACHIEVE REQUIRED SOIL VOLUME FOR TREES.
4. BIKE INFRASTRUCTURE MAY BE REQUIRED AS PER MAPS IN PART A – APPENDIX B.
5. WIDER LANES MAY BE CONSIDERED BASED ON CURBSIDE MANAGEMENT AND/OR OPERATION USE OF THE STREET.
6. SIDEWALKS MAY BE REQUIRED ON BOTH SIDES BASED ON DESTINATIONS AND PEDESTRIAN VOLUMES.
7. TRANSIT LANES 3.3 m MINIMUM.

HALIFAX

STANDARD DETAIL

**REGIONAL CENTRE RESIDENTIAL/
SUBURBAN RESIDENTIAL (LOCAL)**

DATE:	2021	REFERENCE	APPROVED
SCALE:	NTS		FIG No.: HRM 2

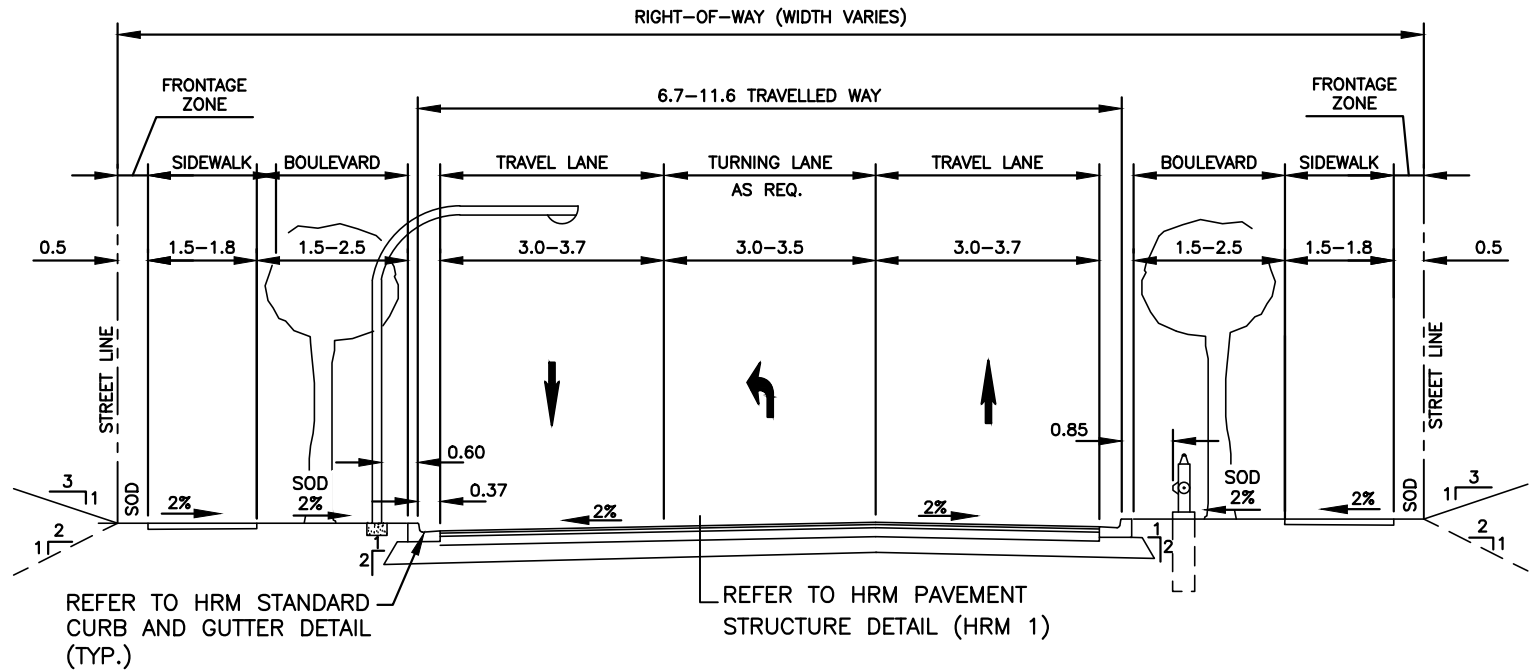

CROSS SECTION

NOTES:

1. SEE SECTION 2.4.2 FOR FURTHER GUIDANCE.
2. LANE WIDTHS DO NOT INCLUDE STANDARD GUTTER WIDTH.
3. BOULEVARD WIDTH OF 1.2 m – 1.5 m MAY BE CONSIDERED IN RETROFIT SITUATIONS, SOIL CELLS MAY BE REQUIRED TO ACHIEVE REQUIRED SOIL VOLUME FOR TREES.
4. WHERE TURNING LANES ARE REQUIRED, FORM BY REMOVING CURBSIDE USE.
5. TRANSIT LANES 3.3 m MIN.
6. BIKE INFRASTRUCTURE MAY BE REQUIRED AS PER MAPS IN PART A – APPENDIX B.
7. PARKING MAY BE ALLOWED ON ONE OR BOTH SIDES.

HALIFAX

STANDARD DETAIL

**REGIONAL CENTRE RESIDENTIAL
(MINOR COLLECTOR)**

DATE:	2021	REFERENCE	APPROVED
SCALE:	NTS		FIG No.: HRM 3

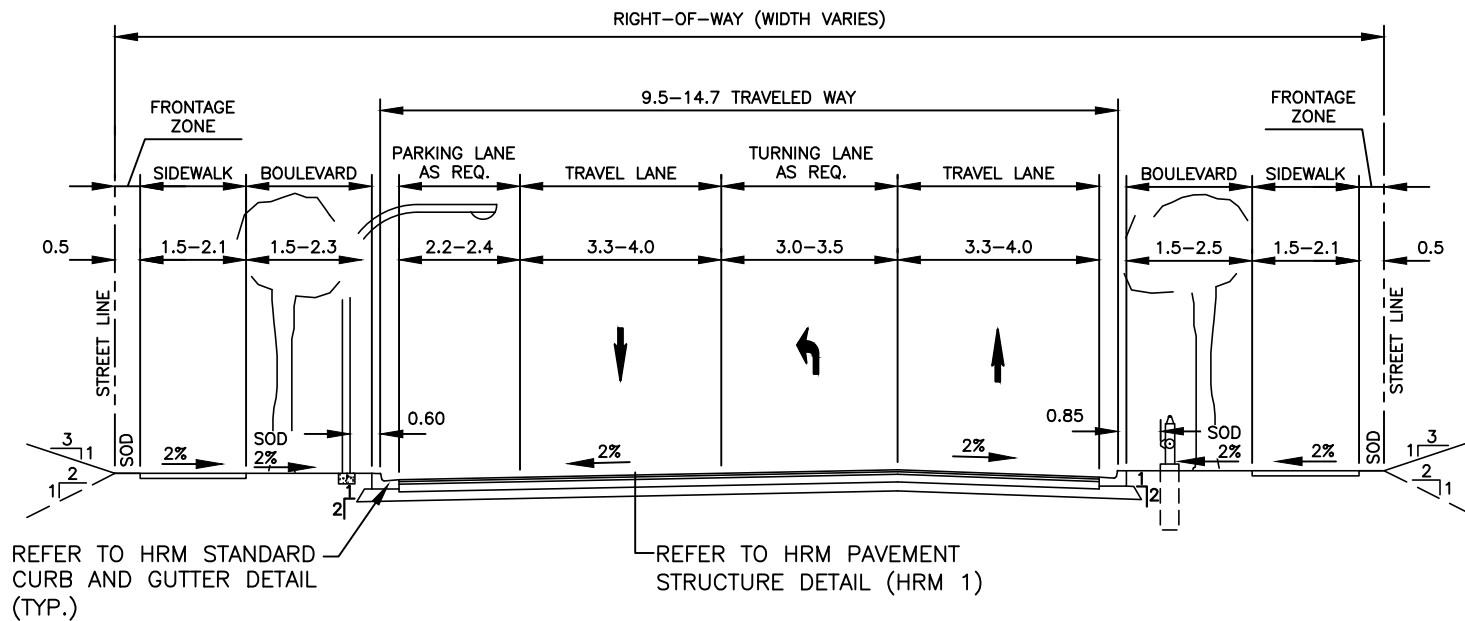

CROSS SECTION

NOTES:

1. SEE SECTION 2.4.2 FOR FURTHER GUIDANCE.
2. LANE WIDTHS DO NOT INCLUDE STANDARD GUTTER WIDTH.
3. BOULEVARD WIDTH OF 1.2 m – 1.5 m MAY BE CONSIDERED IN RETROFIT SITUATIONS, SOIL CELLS MAY BE REQUIRED TO ACHIEVE REQUIRED SOIL VOLUME FOR TREES.
4. TURNING LANES MAY BE FORMED BY REMOVING CURBSIDE USE IN THAT AREA.
5. BIKE INFRASTRUCTURE MAY BE REQUIRED AS PER MAPS IN PART A – APPENDIX B.
6. PARKING LANE WIDTH SHOWN DOES NOT INCLUDE GUTTER WIDTH; IN CASES OF NO GUTTER, ADD 0.25 m TO PARKING LANE WIDTH.

HALIFAX

STANDARD DETAIL

**REGIONAL CENTRE RESIDENTIAL
(MAJOR COLLECTOR)**

DATE:	2021	REFERENCE	APPROVED
SCALE:	NTS		FIG No.: HRM 4

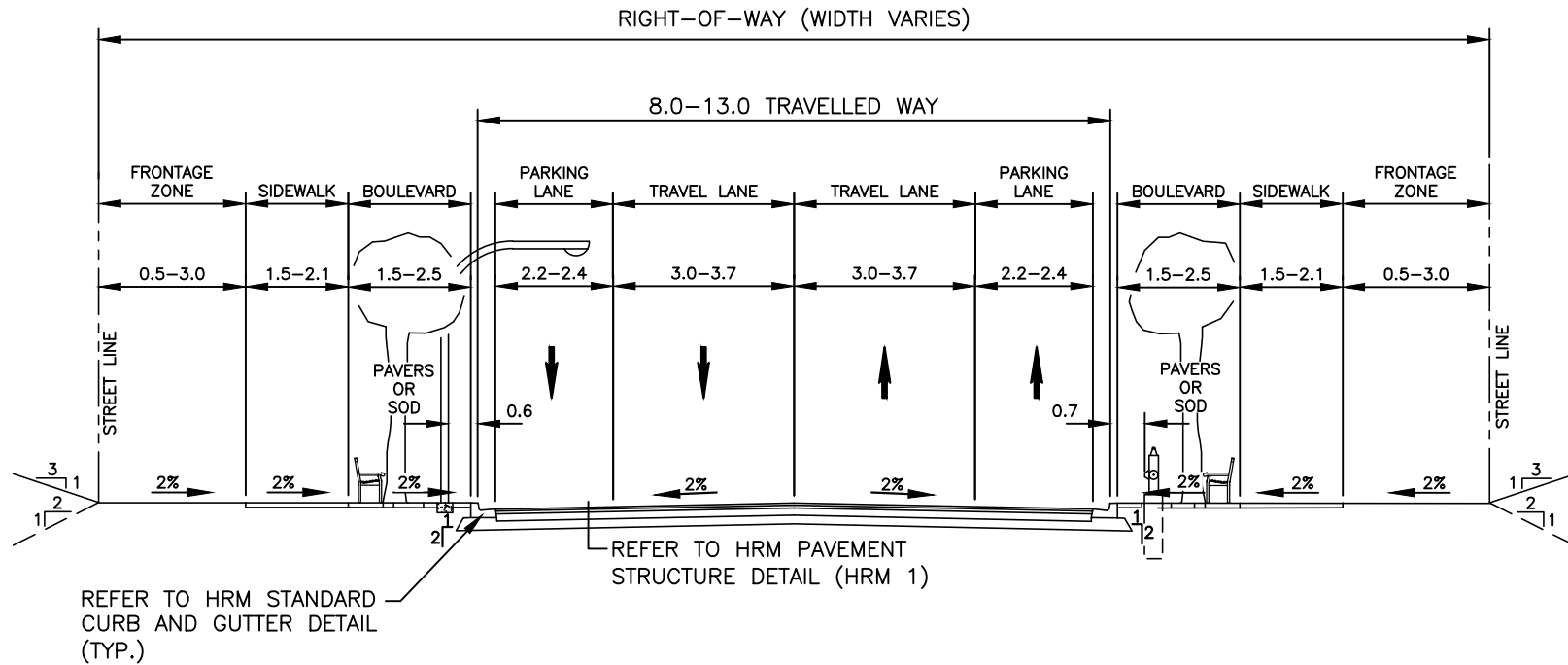

CROSS SECTION

NOTES:

1. SEE SECTION 2.4.2 FOR FURTHER GUIDANCE.
2. LANE WIDTHS DO NOT INCLUDE STANDARD GUTTER WIDTH.
3. PARKING LANE WIDTH SHOWN DOES NOT INCLUDE GUTTER; IN CASES OF NO GUTTER, ADD 0.25 m TO PARKING LANE WIDTH.
4. TRANSIT LANES 3.3 m MIN.
5. BIKE INFRASTRUCTURE MAY BE REQUIRED AS PER MAPS IN PART A – APPENDIX B.
6. BOULEVARD WIDTHS OF 1.2 – 1.5 m MAY BE CONSIDERED IN RETROFIT SITUATIONS. SOIL CELLS MAY BE REQUIRED TO ACHIEVE REQUIRED SOIL VOLUMES FOR TREES.

HALIFAX

STANDARD DETAIL

REGIONAL CENTRE
COMMERCIAL/MIXED USE (LOCAL)

DATE:	2021	REFERENCE	APPROVED
SCALE:	NTS	FIG No.:	HRM 5

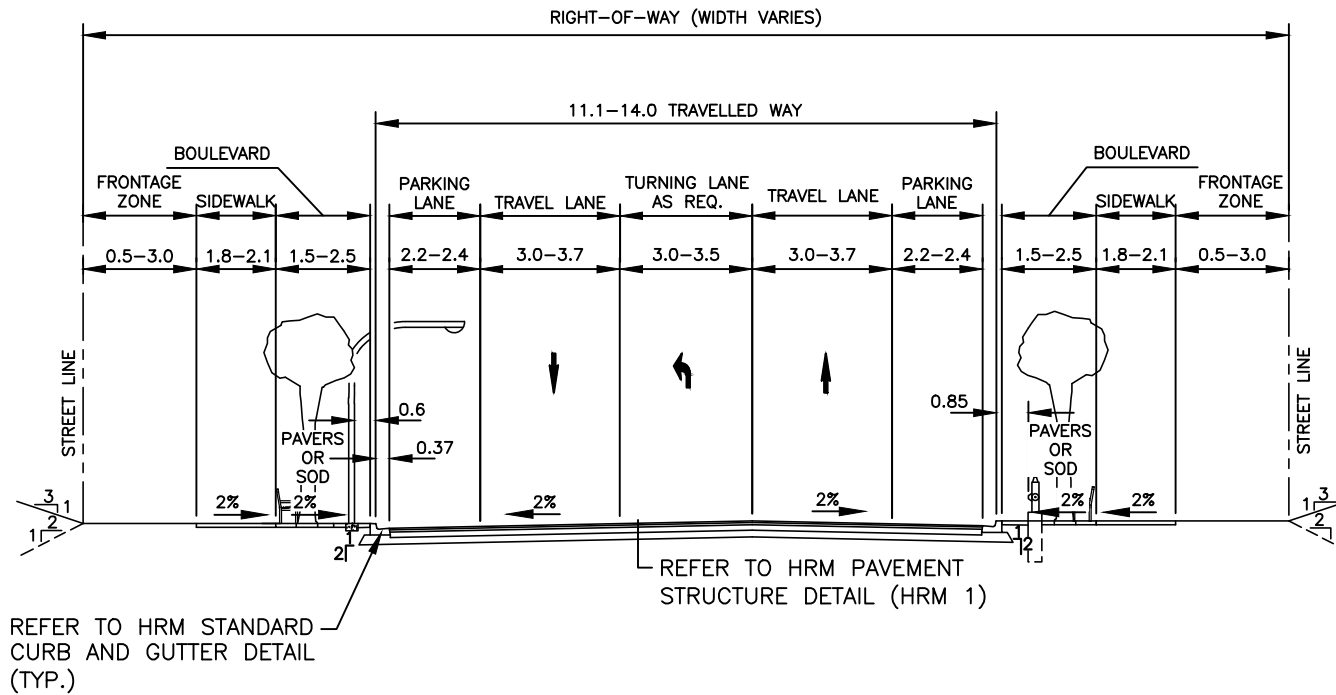

CROSS SECTION

NOTES:

1. SEE SECTION 2.4.2 FOR FURTHER GUIDANCE.
2. LANE WIDTHS DO NOT INCLUDE STANDARD GUTTER WIDTH.
3. TRANSIT LANES 3.3 m MIN.
4. TURNING LANES MAY BE FORMED BY REMOVING CURBSIDE USE IN THAT AREA.
5. BIKE INFRASTRUCTURE MAY BE REQUIRED AS PER MAPS IN PART A – APPENDIX B.
6. PARKING LANE WIDTH SHOWN DOES NOT INCLUDE GUTTER WIDTH; IN CASES OF NO GUTTER, ADD 0.25 m TO PARKING LANE WIDTH.
7. BOULEVARD WIDTHS OF 1.2 – 1.5 m MAY BE CONSIDERED IN RETROFIT SITUATIONS. SOIL CELLS MAY BE REQUIRED TO ACHIEVE REQUIRED SOIL VOLUMES FOR TREES.

HALIFAX

STANDARD DETAIL
REGIONAL CENTRE
COMMERCIAL/MIXED USE
(MINOR COLLECTOR)

DATE:	2021	REFERENCE	APPROVED
SCALE:	NTS		FIG No.: HRM 6

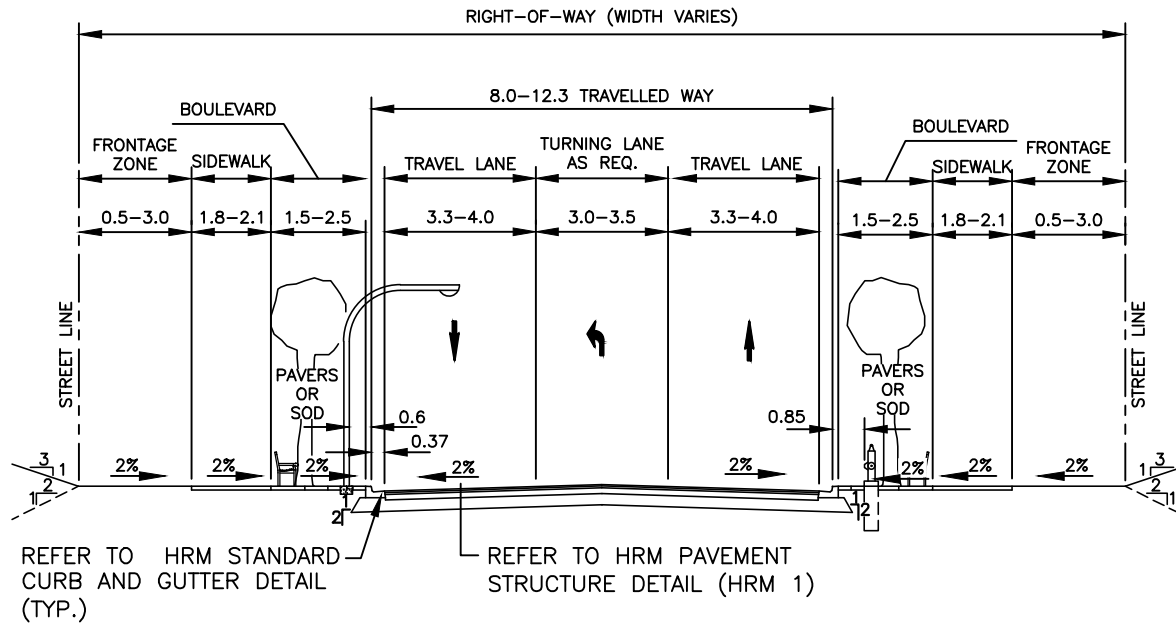

CROSS SECTION

NOTES:

1. SEE SECTION 2.4.2 FOR FURTHER GUIDANCE.
2. LANE WIDTHS DO NOT INCLUDE STANDARD GUTTER WIDTH.
3. TURNING LANES MAY BE FORMED BY REMOVING CURBSIDE USE IN THAT AREA.
4. BIKE INFRASTRUCTURE MAY BE REQUIRED AS PER MAPS IN PART A – APPENDIX B.
5. BOULEVARD WIDTHS OF 1.2 – 1.5 m MAY BE CONSIDERED IN RETROFIT SITUATIONS. SOIL CELLS MAY BE REQUIRED TO ACHIEVE REQUIRED SOIL VOLUMES FOR TREES.
6. IF ON-STREET PARKING IS REQUIRED THEN ADDITIONAL ROADWAY WIDTH WOULD BE REQUIRED. ADDITIONAL WIDTH FOR PARKING LANES TO BE REVIEWED BY THE ENGINEER.
7. ADDITIONAL TRAVEL LANES MAY BE REQUIRED, AS DETERMINED BY A TRAFFIC IMPACT ASSESSMENT.

HALIFAX

STANDARD DETAIL
 REGIONAL CENTRE
 COMMERCIAL/MIXED USE
 (MAJOR COLLECTOR)

DATE:	2021	REFERENCE	APPROVED
SCALE:	NTS	FIG No.:	HRM 7

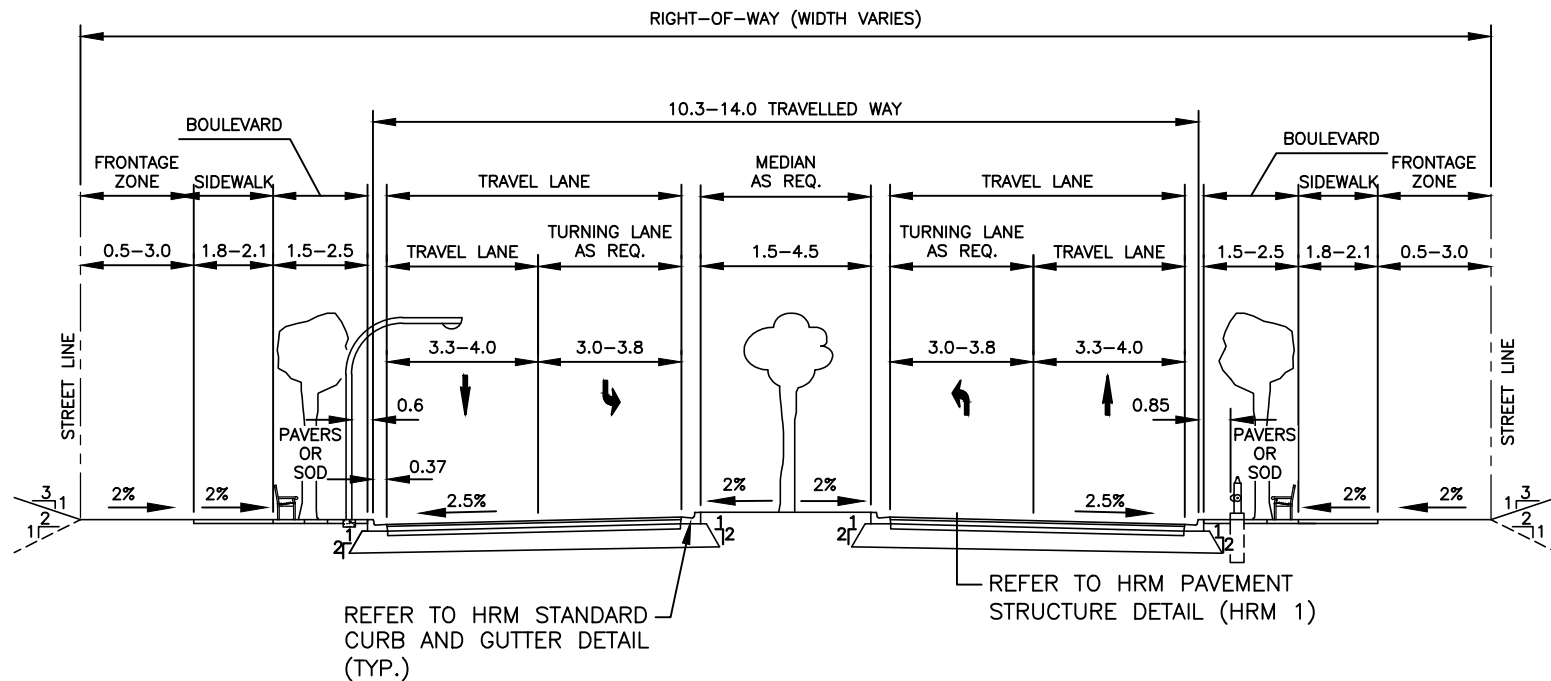

CROSS SECTION

NOTES:

1. SEE SECTION 2.4.2 FOR FURTHER GUIDANCE.
2. LANE WIDTHS DO NOT INCLUDE STANDARD GUTTER WIDTH.
3. TURNING LANES MAY BE FORMED BY REDUCING THE MEDIAN WIDTH, OR MAY BE IN ADDITION TO THE MEDIAN. TURNING LANES MAY BE 3.0 – 3.5 m WIDE.
4. BIKE INFRASTRUCTURE MAY BE REQUIRED AS PER MAPS IN PART A – APPENDIX B.
5. BOULEVARD WIDTHS OF 1.2 – 1.5 m MAY BE CONSIDERED IN RETROFIT SITUATIONS. SOIL CELLS MAY BE REQUIRED TO ACHIEVE REQUIRED SOIL VOLUMES FOR TREES.
6. IF ON-STREET PARKING IS REQUIRED THEN ADDITIONAL ROADWAY WIDTH WOULD BE REQUIRED. ADDITIONAL WIDTH FOR PARKING LANES TO BE REVIEWED BY THE ENGINEER.
7. ADDITIONAL TRAVEL LANES MAY BE REQUIRED, AS DETERMINED BY A TRAFFIC IMPACT ASSESSMENT. WIDTH OF ADDITIONAL TRAVEL LANES MAY RANGE FROM 3.3 – 3.8 m.

HALIFAX

STANDARD DETAIL

**REGIONAL CENTRE
COMMERCIAL/MIXED USE (ARTERIAL)**

DATE:	2021	REFERENCE	APPROVED
SCALE:	NTS		FIG No.: HRM 8

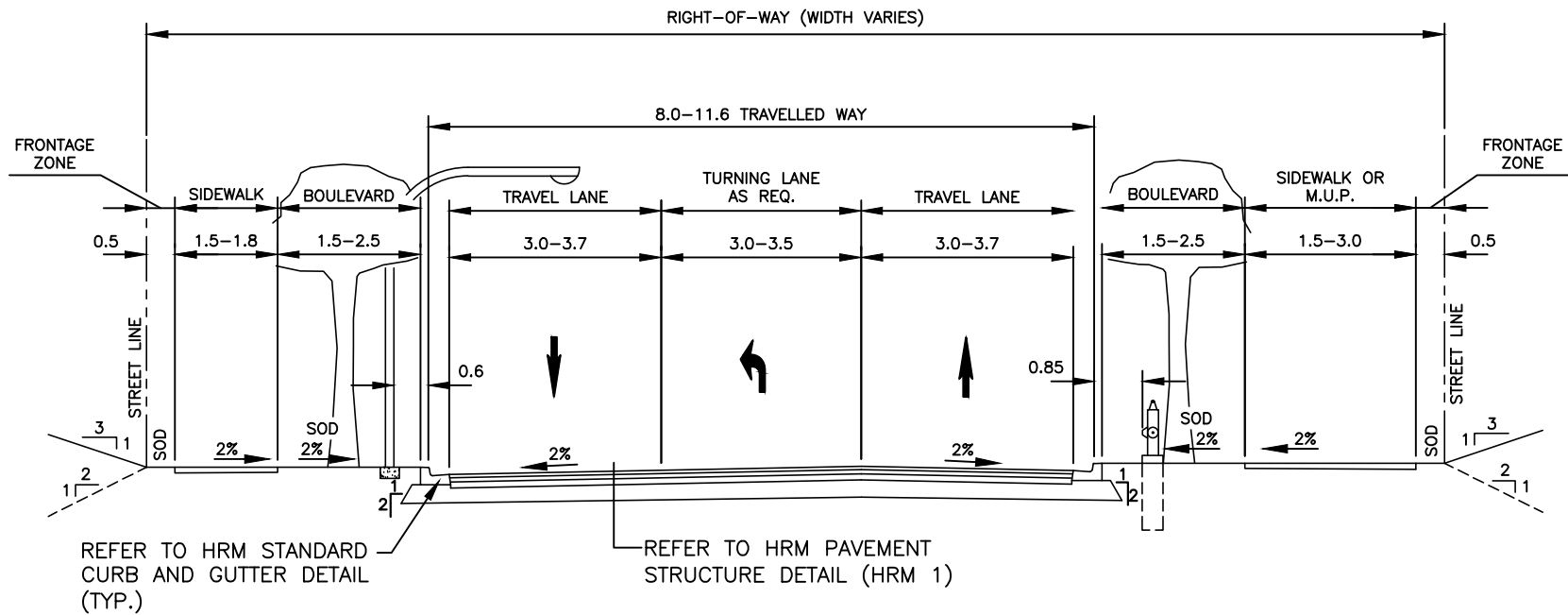

CROSS SECTION

NOTES:

1. SEE SECTION 2.2.2 FOR FURTHER GUIDANCE.
2. LANE WIDTHS DO NOT INCLUDE STANDARD GUTTER WIDTH.
3. TRANSIT LANES 3.3 m MIN.
4. BIKE INFRASTRUCTURE MAY BE REQUIRED AS PER MAPS IN PART A – APPENDIX B.
5. TURNING LANES MAY BE FORMED BY REMOVING CURBSIDE USE IN THAT AREA.
6. USE OF A MULTI-USE PATH IN LIEU OF SIDEWALK MAY BE ACCEPTED. SEE SECTION 2.2.2 FOR MULTI-USE PATH REQUIREMENTS.
7. IF ON-STREET PARKING IS REQUIRED THEN ADDITIONAL ROADWAY WIDTH WOULD BE REQUIRED. ADDITIONAL WIDTH FOR PARKING LANES TO BE REVIEWED BY THE ENGINEER.

HALIFAX

STANDARD DETAIL

**SUBURBAN
(MINOR COLLECTOR)**

DATE:	2021	REFERENCE	APPROVED
SCALE:	NTS		FIG No.: HRM 9

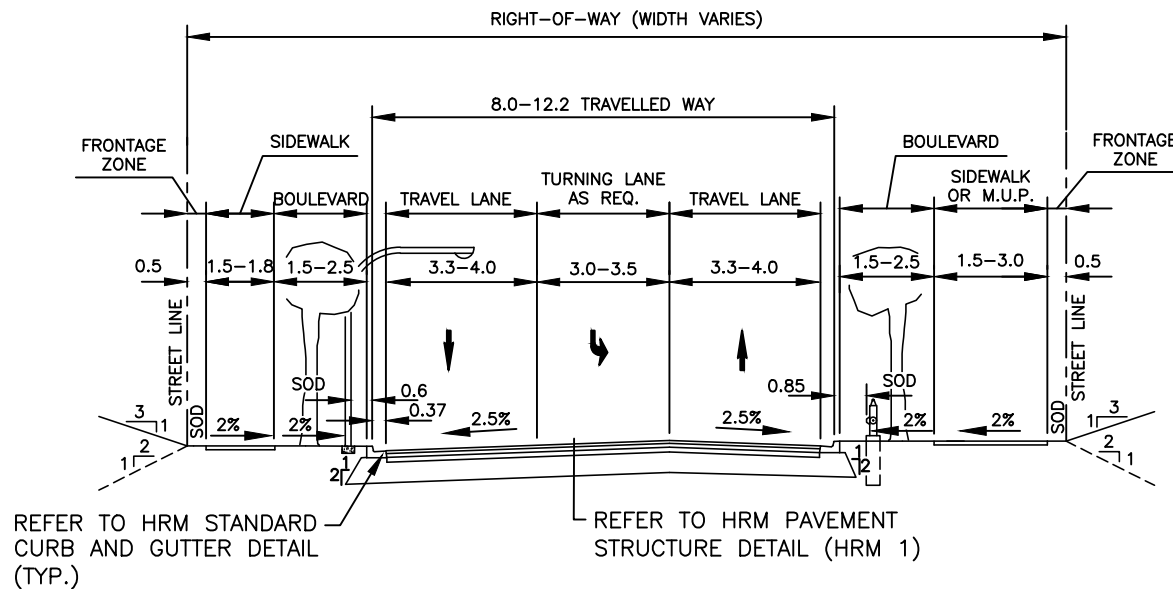

CROSS SECTION

NOTES:

1. SEE SECTION 2.4.2 FOR FURTHER GUIDANCE.
2. LANE WIDTHS DO NOT INCLUDE STANDARD GUTTER WIDTH.
3. BIKE INFRASTRUCTURE MAY BE REQUIRED AS PER MAPS IN PART A – APPENDIX B.
4. USING A MULTI-USE PATH IN LIEU OF ONE SIDEWALK MAY BE ACCEPTED. SEE SECTION 2.2.2 FOR MULTI-USE PATH WIDTH REQUIREMENTS.
5. ADDITIONAL TRAVEL LANES MAY BE REQUIRED, AS DETERMINED BY A TRAFFIC IMPACT ASSESSMENT. WIDTH OF ADDITIONAL TRAVEL LANES MY RANGE FROM 3.3 – 3.8 m.

HALIFAX		
STANDARD DETAIL		
SUBURBAN (MAJOR COLLECTOR)		
DATE:	2021	REFERENCE
SCALE:	NTS	APPROVED
		FIG No.:
		HRM 10

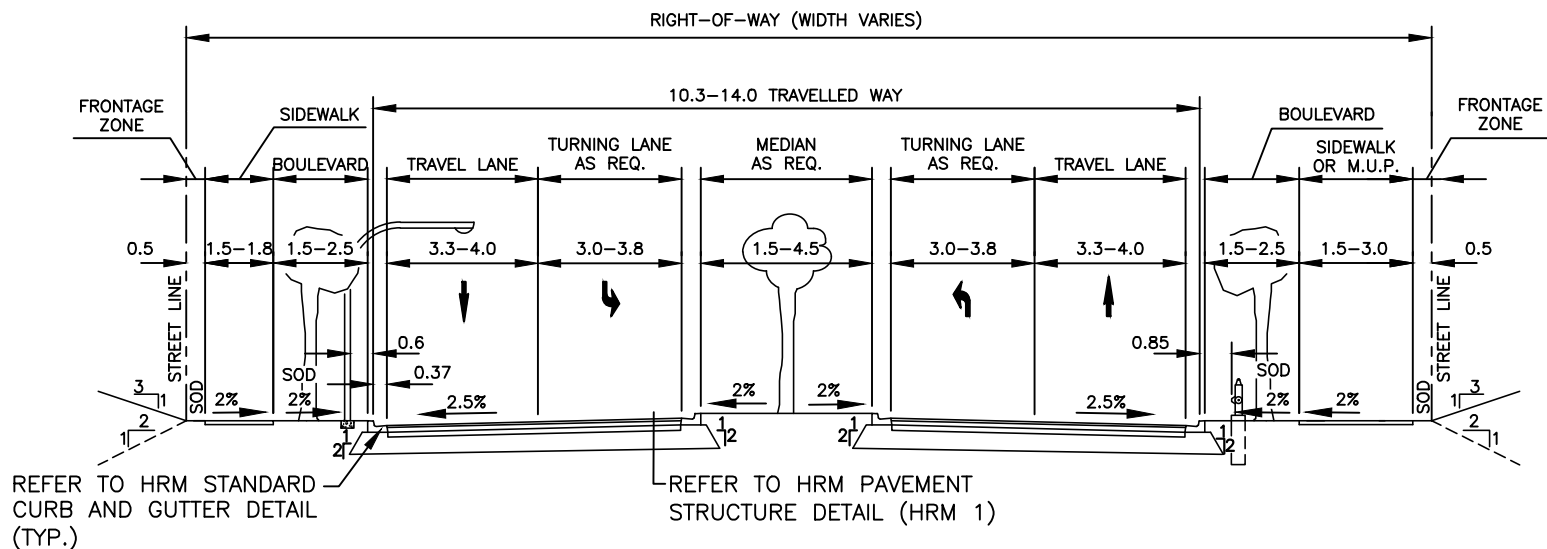

CROSS SECTION

NOTES:

1. SEE SECTION 2.4.2 FOR FURTHER GUIDANCE.
2. LANE WIDTHS DO NOT INCLUDE STANDARD GUTTER WIDTH.
3. TURNING LANES MAY BE FORMED BY REDUCING THE MEDIAN WIDTH.
4. BIKE INFRASTRUCTURE MAY BE REQUIRED AS PER MAPS IN PART A – APPENDIX B.
5. USING A MULTI-USE PATH IN LIEU OF ONE SIDEWALK MAY BE ACCEPTED. SEE SECTION 2.2.2 FOR REQUIRED MULTI-USE PATH WIDTH.
6. ADDITIONAL TRAVEL LANES MAY BE REQUIRED, AS DETERMINED BY A TRAFFIC IMPACT ASSESSMENT. WIDTH OF ADDITIONAL TRAVEL LANES MAY RANGE FROM 3.3 – 3.8 m.

HALIFAX

STANDARD DETAIL

**SUBURBAN
(ARTERIAL)**

DATE:	2021	REFERENCE	APPROVED
SCALE:	NTS		FIG No.: HRM 11

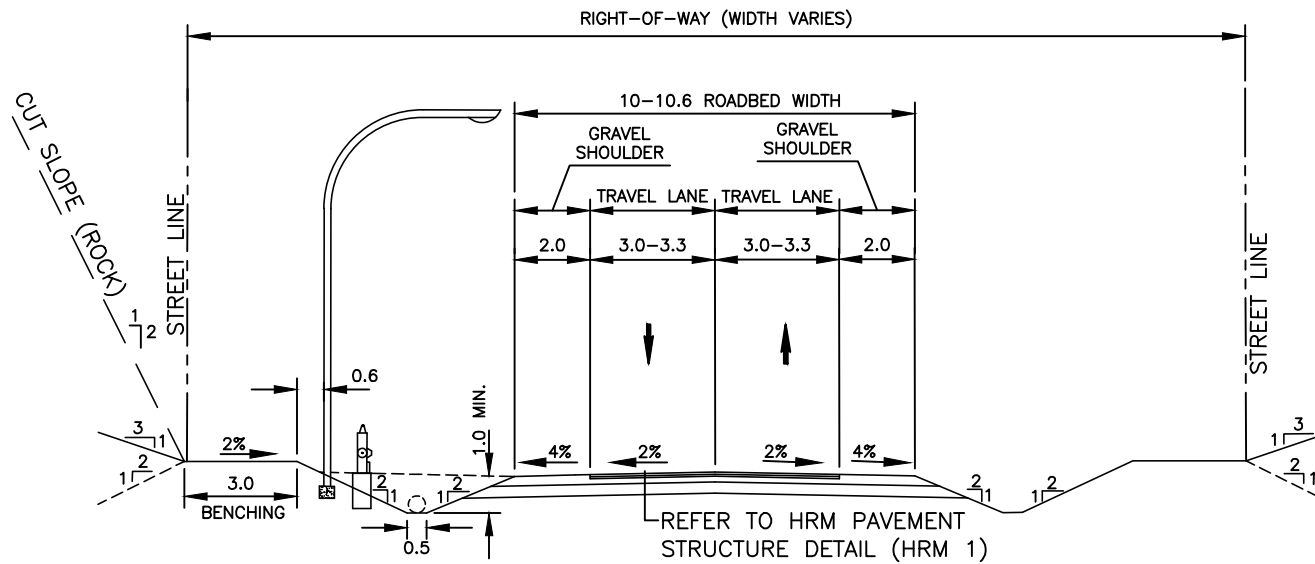

CROSS SECTION

NOTES:

1. SEE SECTION 2.4.2 FOR FURTHER GUIDANCE.
2. BIKE INFRASTRUCTURE MAY BE REQUIRED AS PER MAPS IN PART A – APPENDIX B.
3. R.O.W. SHALL EXTEND TO BACK SLOPE OF DAYLIGHT DITCH.
4. FOR RURAL ROADS HAVING A GRADE EXCEEDING 7%, ASPHALT SWALES ARE REQUIRED ON EACH SIDE OF THE ROAD (ABUTTING THE ASPHALT TRAVEL WAY) WITH AN ASPHALT SWALE RUNOFF TO THE DITCH EVERY 30 m.
5. FALSE DITCH REQUIREMENTS SHALL MEET HALIFAX WATER SPECIFICATIONS.
6. WHERE DIRECTED BY THE ENGINEER, SIDEWALKS SHALL BE INSTALLED AS PER HRM 45, 46 OR 47.

HALIFAX

STANDARD DETAIL

RURAL (LOCAL)

DATE:	2021	REFERENCE	APPROVED
SCALE:	NTS		FIG No.: HRM 12

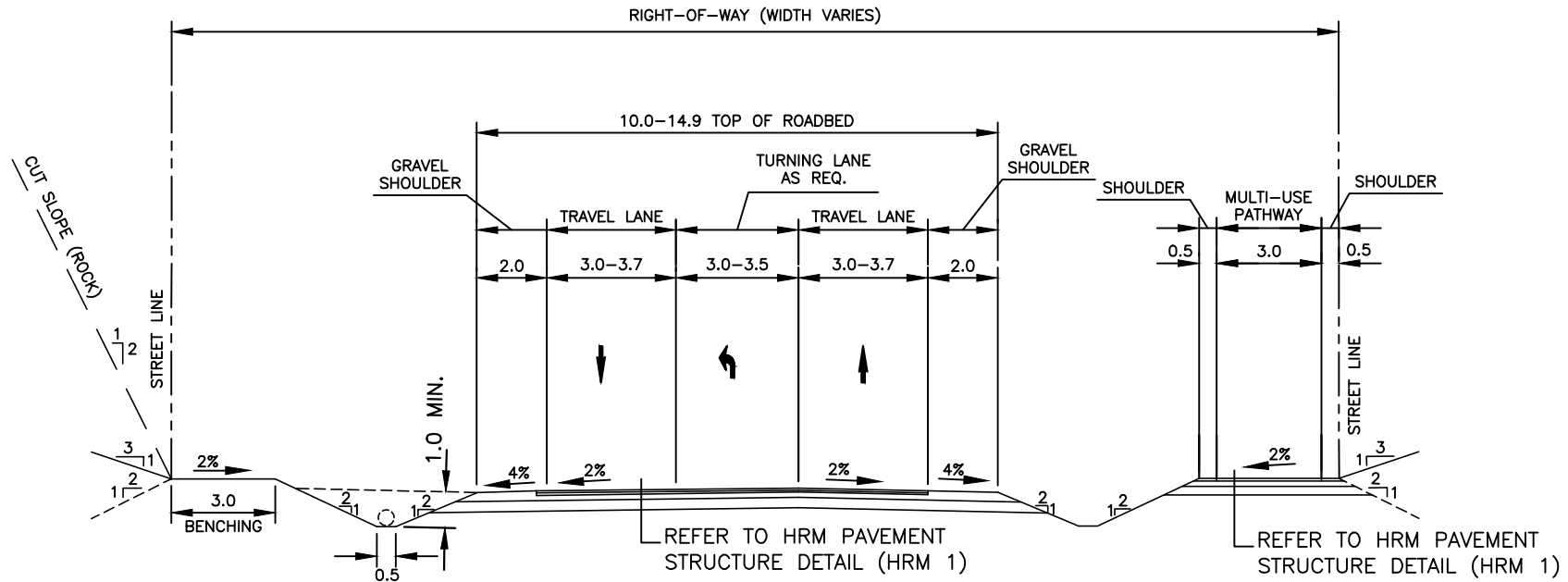

CROSS SECTION

NOTES:

1. SEE SECTION 2.4.2 FOR FURTHER GUIDANCE.
2. BIKE INFRASTRUCTURE MAY BE REQUIRED AS PER MAPS IN PART A – APPENDIX B.
3. R.O.W. SHALL EXTEND TO BACKSLOPE OF DAYLIGHT DITCH.
4. FOR RURAL ROADS HAVING A GRADE EXCEEDING 7%, ASPHALT SWALES ARE REQUIRED ON EACH SIDE OF THE ROAD (ABUTTING THE ASPHALT TRAVEL WAY) WITH AN ASPHALT SWALE RUNOFF TO THE DITCH EVERY 30 m.
5. FALSE DITCH REQUIREMENTS SHALL MEET HALIFAX WATER SPECIFICATIONS.

HALIFAX

STANDARD DETAIL

RURAL
(MINOR COLLECTOR)

DATE:	2021	REFERENCE	APPROVED
SCALE:	NTS		FIG No.: HRM 13

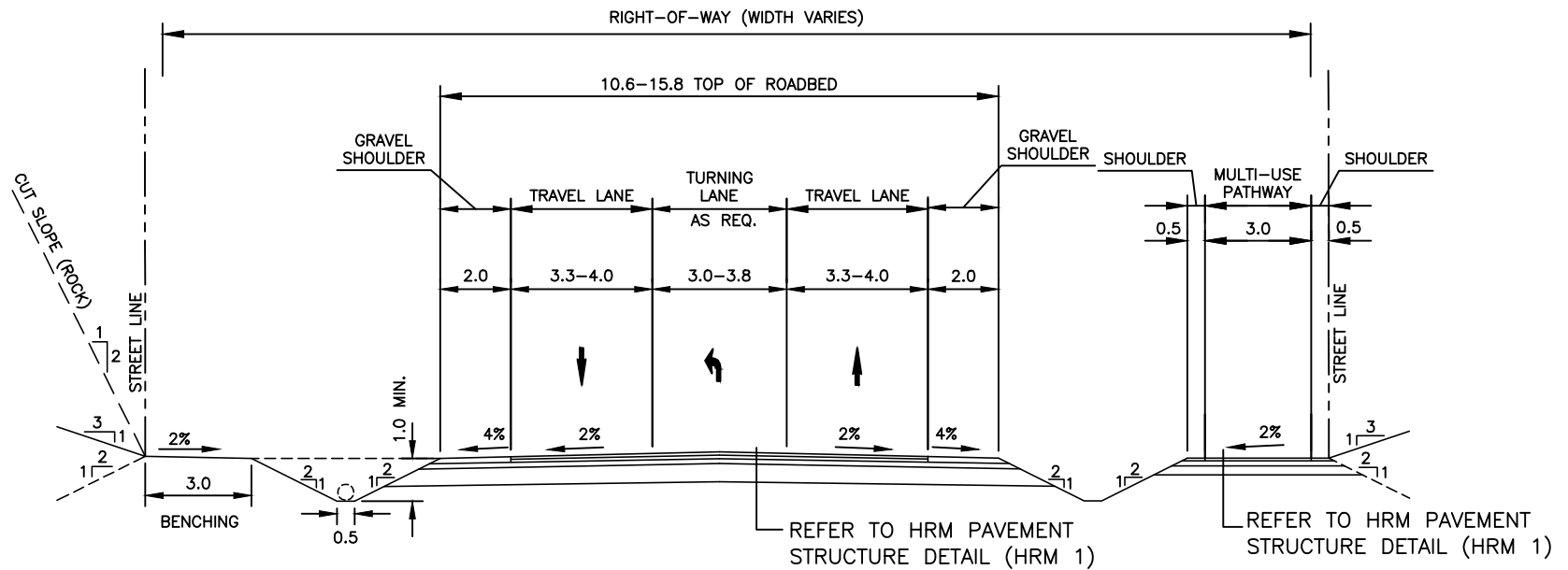

CROSS SECTION

NOTES:

1. SEE SECTION 2.4.2 FOR FURTHER GUIDANCE.
2. BIKE INFRASTRUCTURE MAY BE REQUIRED AS PER MAPS IN PART A – APPENDIX B.
3. R.O.W. SHALL EXTEND TO BACKSLOPE OF DAYLIGHT DITCH.
4. FOR RURAL ROADS HAVING A GRADE EXCEEDING 7%, ASPHALT SWALES ARE REQUIRED ON EACH SIDE OF THE ROAD (ABUTTING THE ASPHALT TRAVEL WAY) WITH AN ASPHALT SWALE RUNOFF TO THE DITCH EVERY 30 m.
5. FALSE DITCH REQUIREMENTS SHALL MEET HALIFAX WATER SPECIFICATIONS.

HALIFAX

STANDARD DETAIL

**RURAL
(MAJOR COLLECTOR)**

DATE:	2021	REFERENCE	APPROVED
SCALE:	NTS		FIG No.: HRM 14

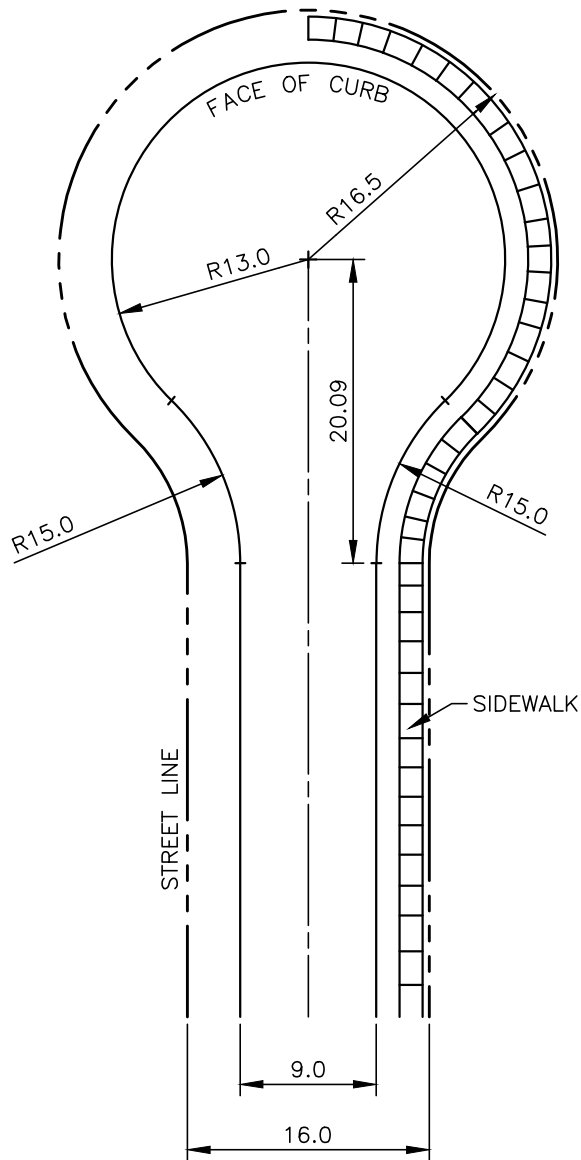

TYPE 1
SYMMETRICAL CUL-DE-SAC

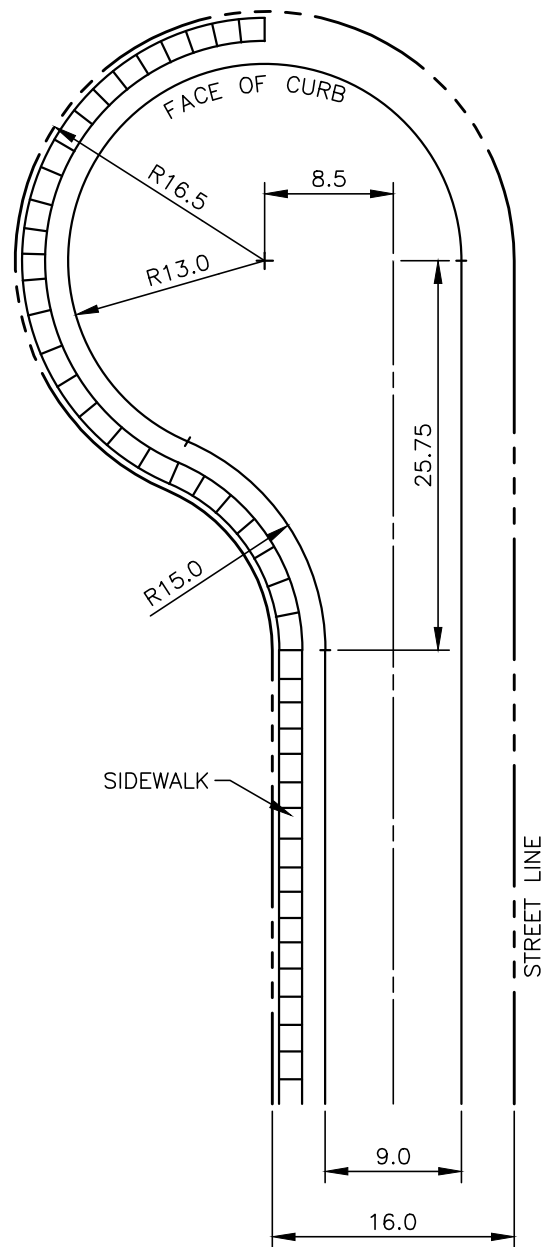

TYPE 2
LEFT OFFSET CUL-DE-SAC

NOTE:

RIGHT OFFSET CUL-DE-SAC IS ALSO PERMITTED.

HALIFAX

STANDARD DETAIL

URBAN LOCAL CUL-DE-SAC

DATE:	2021	REFERENCE	APPROVED
SCALE:	1:500		FIG No.: HRM 15

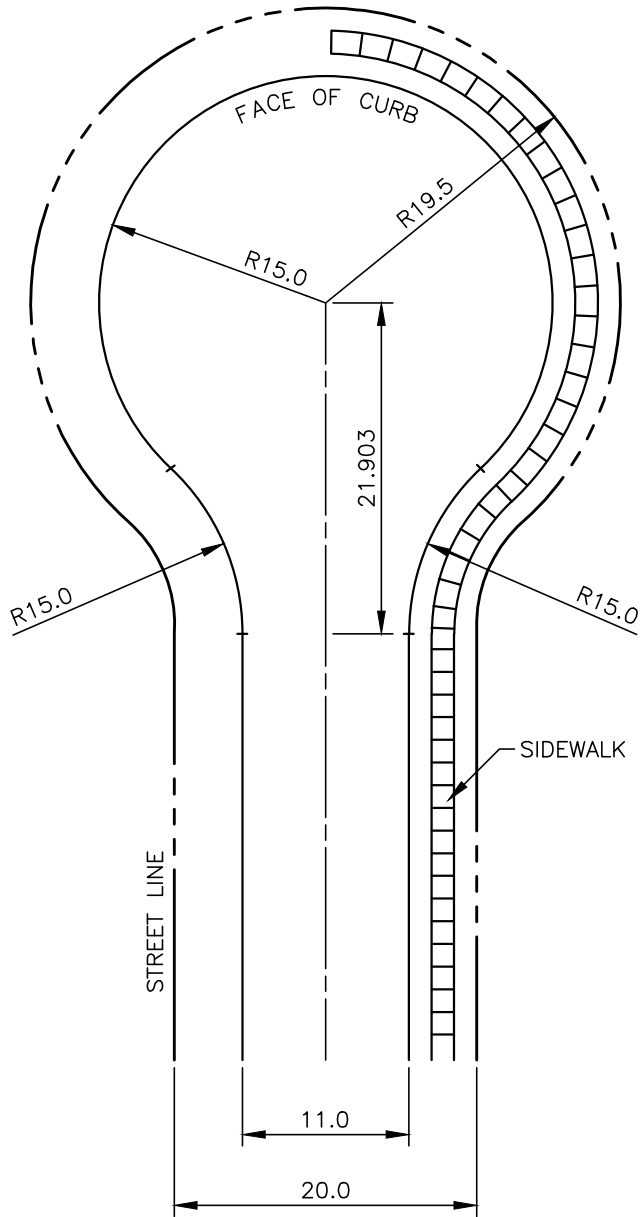

SYMMETRICAL CUL-DE-SAC

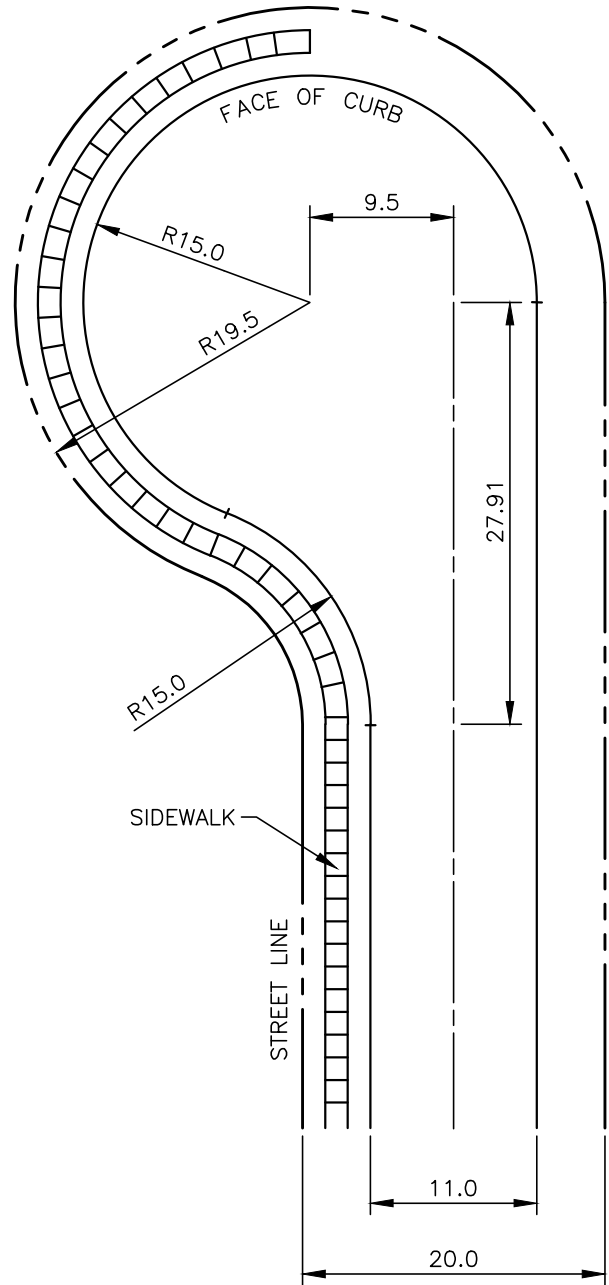

LEFT OFFSET CUL-DE-SAC

NOTE:

RIGHT OFFSET CUL-DE-SAC IS ALSO PERMITTED.

HALIFAX

STANDARD DETAIL

URBAN INDUSTRIAL
CUL-DE-SAC

DATE:	2021	REFERENCE	APPROVED
SCALE:	1:500		FIG No.: HRM 16

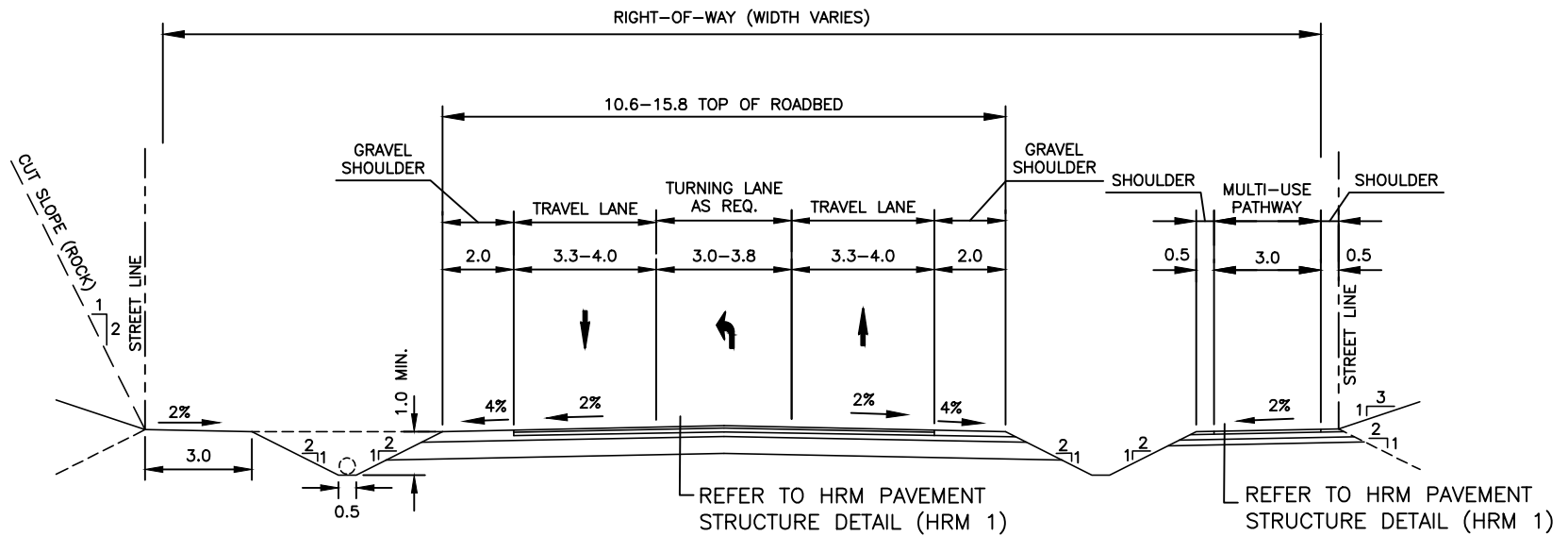

CROSS SECTION

NOTES:

- SEE SECTION 2.4.2 FOR FURTHER GUIDANCE.
- BIKE INFRASTRUCTURE MAY BE REQUIRED AS PER MAPS IN PART A – APPENDIX B.
- MEDIAN OPTIONAL. WHERE MEDIAN IS PLACED, TURN LANES MAY BE FORMED BY REDUCING MEDIAN WIDTH.
- R.O.W. SHALL EXTEND TO BACKSLOPE OF DAYLIGHT DITCH.
- FOR RURAL ROADS HAVING A GRADE EXCEEDING 7%, ASPHALT SWALES ARE REQUIRED ON EACH SIDE OF THE ROAD (ABUTTING THE ASPHALT TRAVEL WAY) WITH AN ASPHALT SWALE RUNOFF TO THE DITCH EVERY 30 m.
- FALSE DITCH REQUIREMENTS SHALL MEET HALIFAX WATER SPECIFICATIONS.
- ADDITIONAL TRAVEL LANES MAY BE REQUIRED, AS DETERMINED BY A TRAFFIC IMPACT ASSESSMENT. WIDTH OF ADDITIONAL TRAVEL LANES MAY RANGE FROM 3.3 – 3.8 m.

HALIFAX

STANDARD DETAIL

RURAL (ARTERIAL)

DATE:	2021	REFERENCE	APPROVED
SCALE:	NTS	FIG No.:	HRM 17

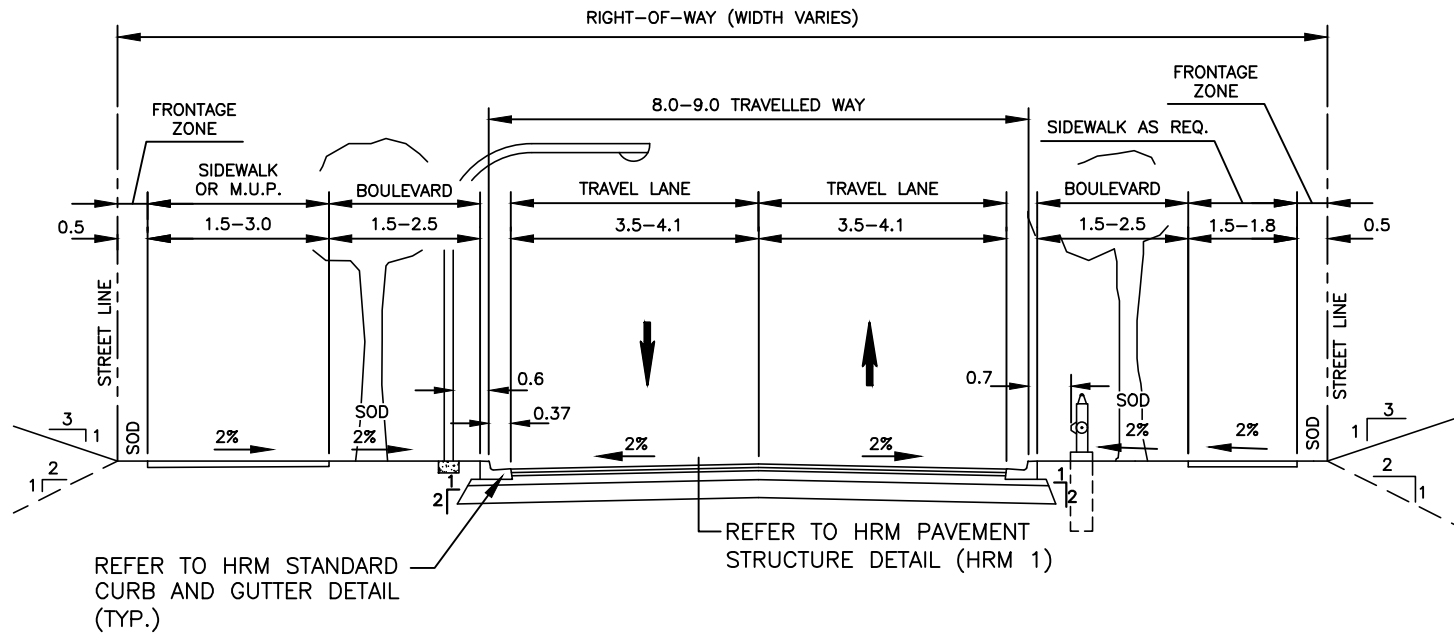

CROSS SECTION

NOTES:

1. SEE SECTION 2.4.2 FOR FURTHER GUIDANCE.
2. LANE WIDTHS DO NOT INCLUDE STANDARD GUTTER WIDTH.
3. BIKE INFRASTRUCTURE MAY BE REQUIRED AS PER MAPS IN PART A – APPENDIX B.
4. A MULTI-USE PATH MAY BE USED IN LIEU OF A SIDEWALK. SEE SECTION 2.2.2 FOR REQUIRED MULTI-USE PATH WIDTH.
5. SIDEWALKS MAY BE REQUIRED ON BOTH SIDES BASED ON DESTINATIONS AND PEDESTRIAN VOLUMES.

HALIFAX

STANDARD DETAIL

**INDUSTRIAL
(LOCAL)**

DATE:	2021	REFERENCE	APPROVED
SCALE:	NTS		FIG No.: HRM 18

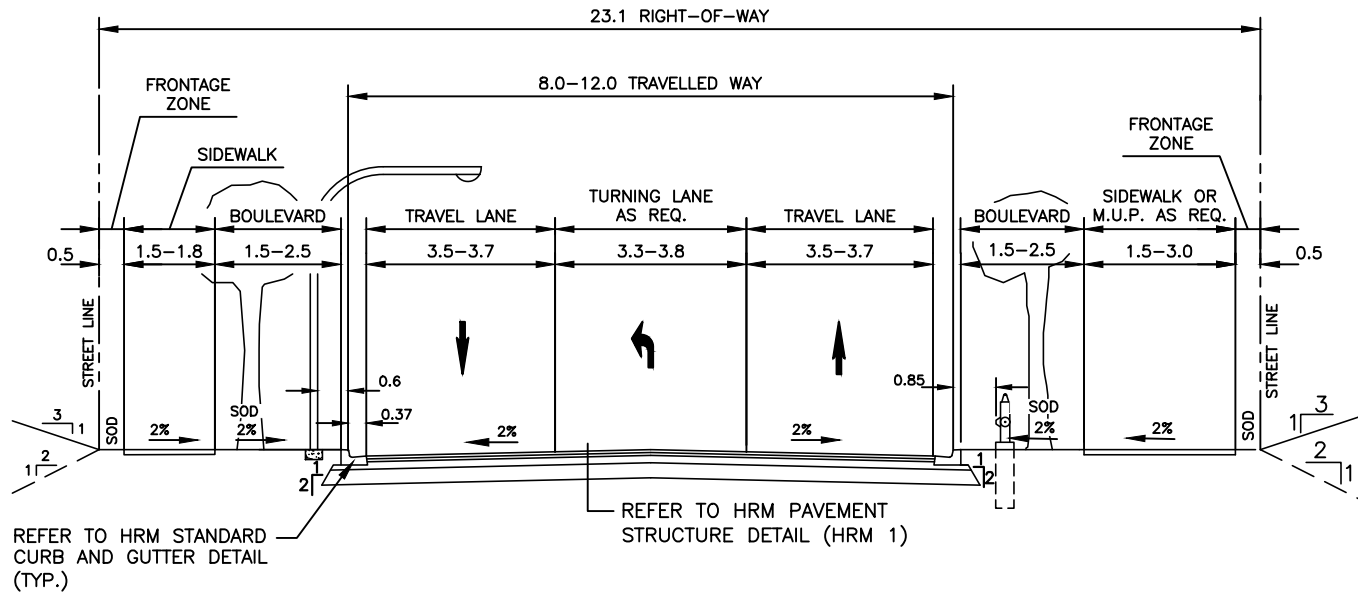

CROSS SECTION

NOTES:

1. SEE SECTION 2.4.2 FOR FURTHER GUIDANCE.
2. LANE WIDTHS DO NOT INCLUDE STANDARD GUTTER WIDTH.
3. TURNING LANES MAY BE FORMED BY LIMITING CURBSIDE USE IN THAT AREA.
4. BIKE INFRASTRUCTURE MAY BE REQUIRED AS PER MAPS IN PART A - APPENDIX B.
5. A MULTI-USE PATH MAY BE USED IN LIEU OF A SIDEWALK. SEE SECTION 2.2.2 FOR REQUIRED MULTI-USE PATH WIDTH.

HALIFAX

STANDARD DETAIL

**INDUSTRIAL
(MINOR COLLECTOR)**

DATE:	2021	REFERENCE	APPROVED
SCALE:	NTS	FIG No.:	HRM 19

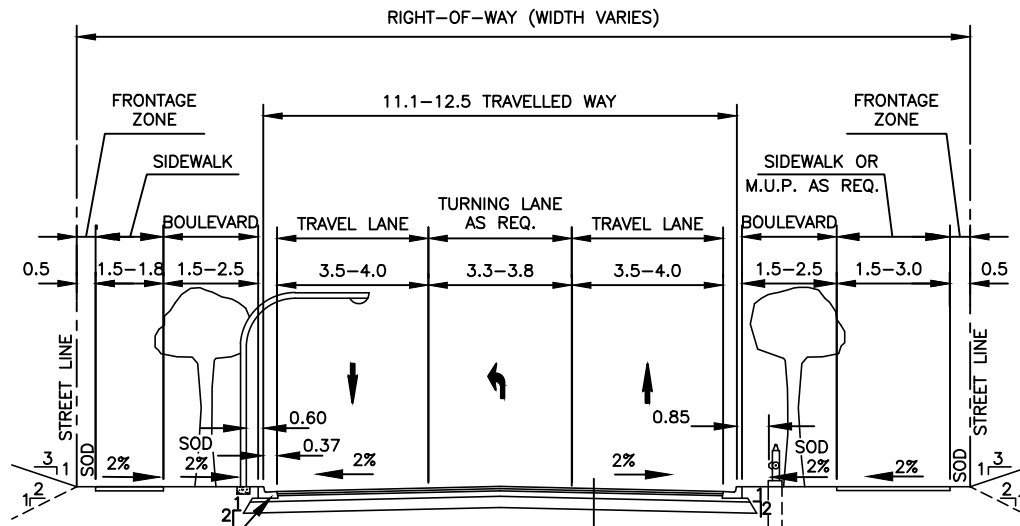

REFER TO HRM STANDARD
CURB AND GUTTER DETAIL
(TYP.)

REFER TO HRM PAVEMENT
STRUCTURE DETAIL (HRM 1)

CROSS SECTION

NOTE:

1. SEE SECTION 2.4.2 FOR FURTHER GUIDANCE.
2. LANE WIDTHS DO NOT INCLUDE STANDARD GUTTER WIDTH.
3. BIKE INFRASTRUCTURE MAY BE REQUIRED AS PER MAPS IN PART A – APPENDIX B..
4. MULTI-USE PATH MAY BE USED IN LIEU OF SIDEWALK. SEE SECTION 2.2.2 FOR REQUIRED MULTI-USE PATH WIDTH.

HALIFAX

STANDARD DETAIL

**INDUSTRIAL
(MAJOR COLLECTOR)**

DATE:	2021	REFERENCE	APPROVED
SCALE:	NTS		FIG No.: HRM 20

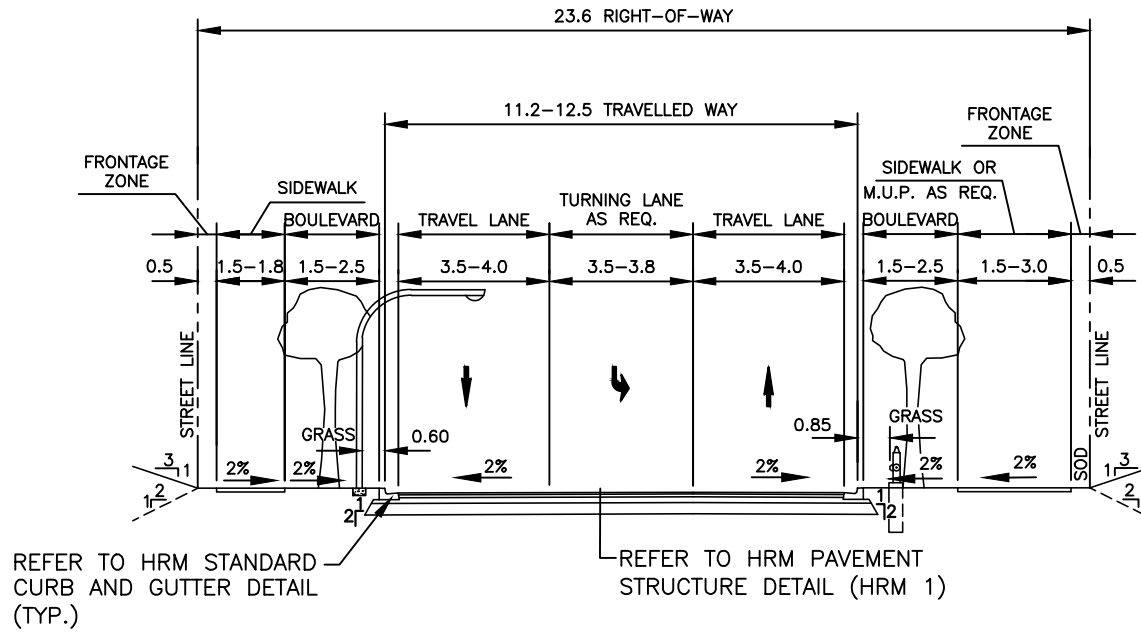

CROSS SECTION

NOTES:

1. SEE SECTION 2.4.2 FOR FURTHER GUIDANCE.
2. LANE WIDTHS DO NOT INCLUDE STANDARD GUTTER WIDTH.
3. BIKE INFRASTRUCTURE MAY BE REQUIRED AS PER MAPS IN PART A – APPENDIX B.
4. MULTI-USE PATH MAY BE USED IN LIEU OF SIDEWALK. SEE SECTION 2.2.2 FOR REQUIRED MULTI-USE PATH WIDTH.
5. MEDIAN OPTIONAL. WHERE MEDIAN IS USED, TURN LANES MAY BE FORMED BY REDUCING MEDIAN WIDTH.
6. ADDITIONAL TRAVEL LANES MAY BE REQUIRED, AS DETERMINED BY A TRAFFIC IMPACT ASSESSMENT. WIDTH OF ADDITIONAL TRAVEL LANES MAY RANGE FROM 3.3 – 3.8 m.

HALIFAX		
STANDARD DETAIL		
INDUSTRIAL (ARTERIAL)		
DATE:	2021	REFERENCE
SCALE:	NTS	APPROVED
		FIG No.:
		HRM 21

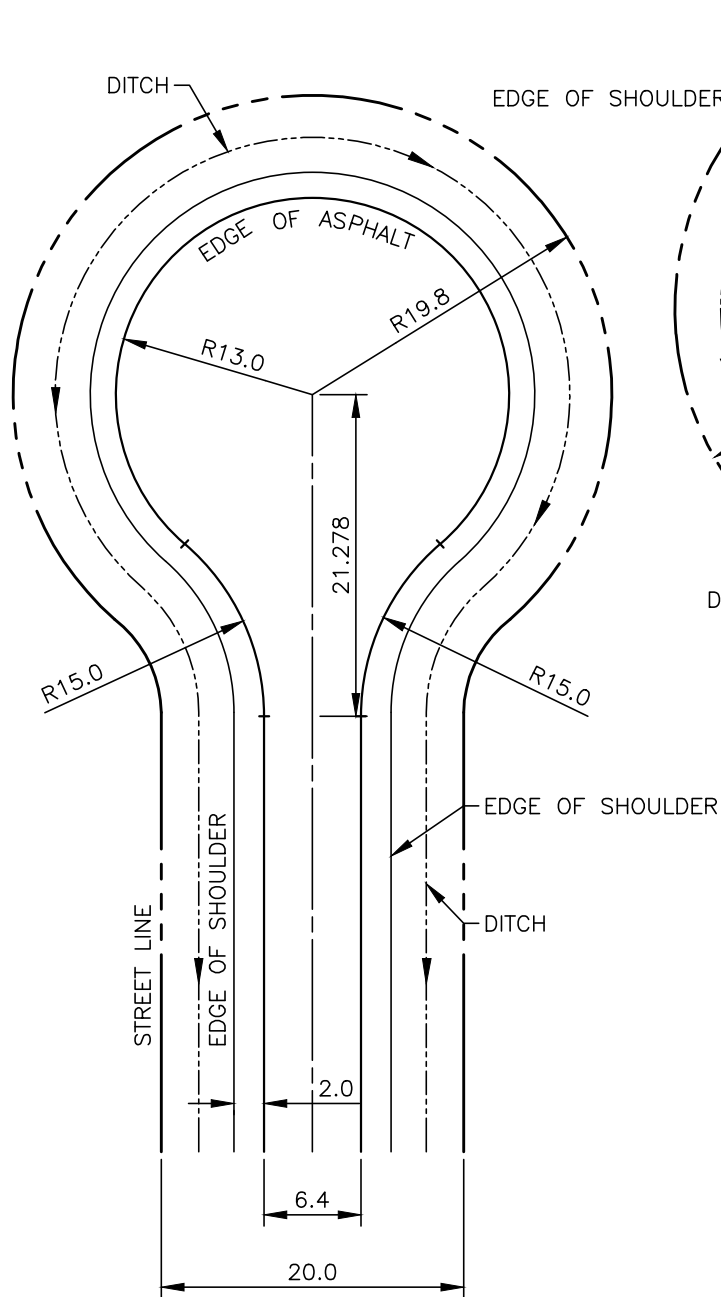

SYMMETRICAL CUL-DE-SAC

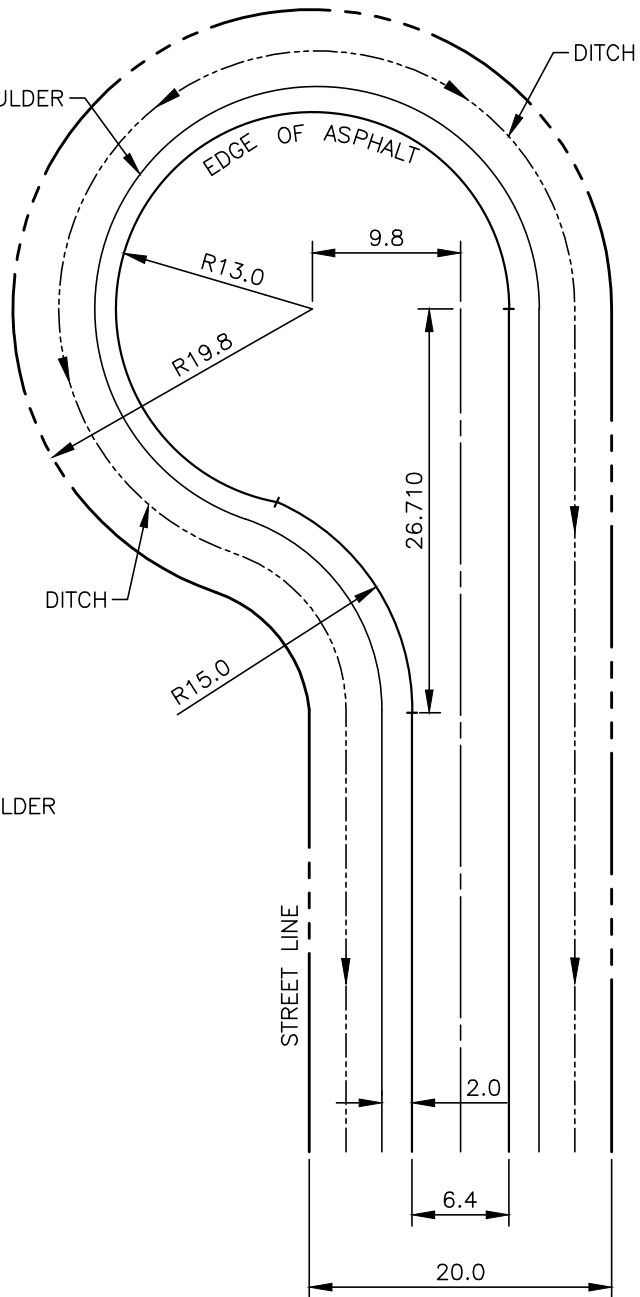

LEFT OFFSET CUL-DE-SAC

NOTE:

RIGHT OFFSET CUL-DE-SAC IS ALSO PERMITTED.

HALIFAX

STANDARD DETAIL

RURAL LOCAL
CUL-DE-SAC

DATE:	2021	REFERENCE	APPROVED
SCALE:	1:500		FIG No.: HRM 27

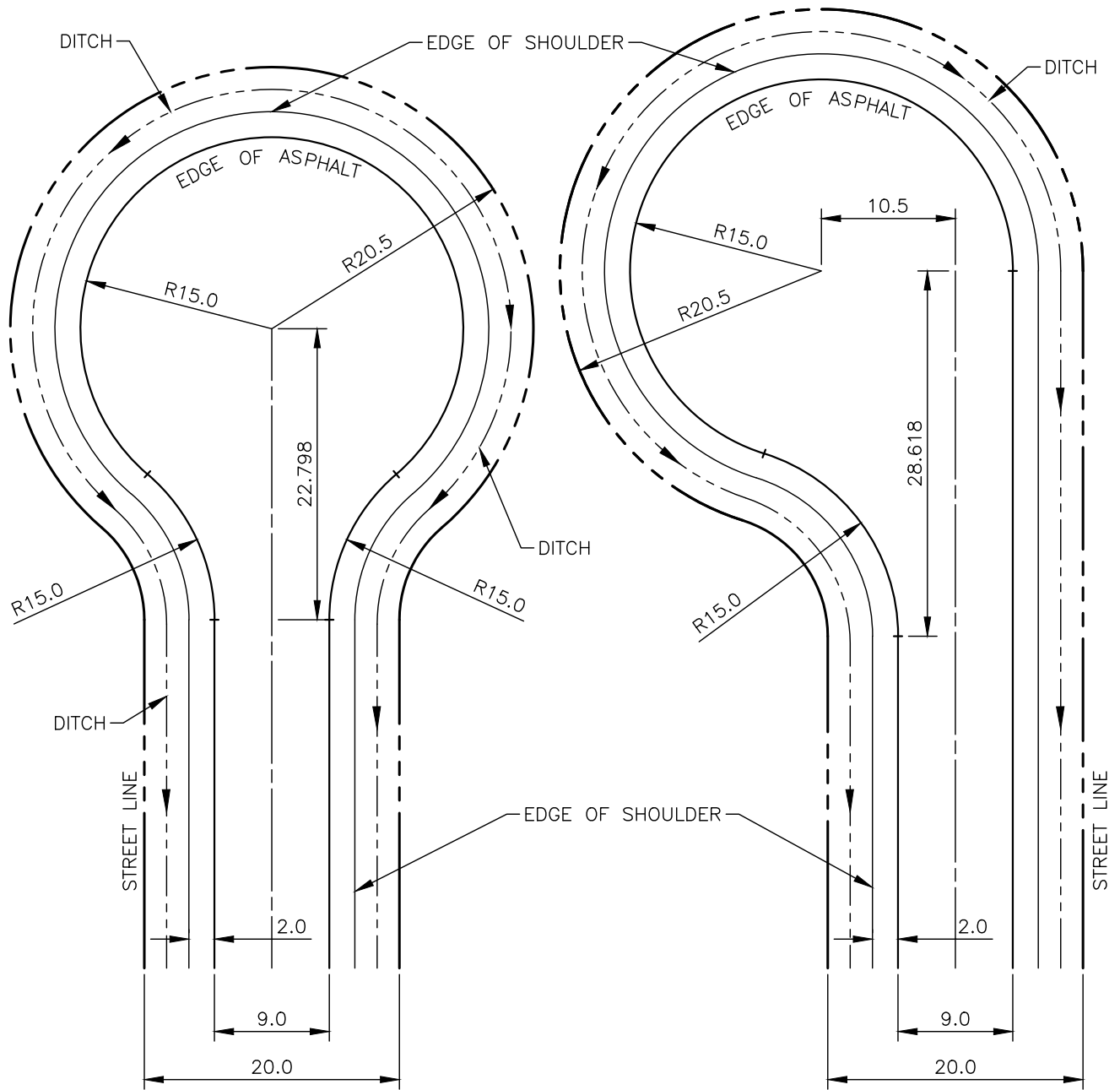

SYMMETRICAL CUL-DE-SAC

LEFT OFFSET CUL-DE-SAC

NOTE:

RIGHT OFFSET CUL-DE-SAC IS ALSO PERMITTED.

HALIFAX

STANDARD DETAIL

RURAL INDUSTRIAL
CUL-DE-SAC

DATE:	2021	REFERENCE	APPROVED
SCALE:	1:500		FIG No.: HRM 28

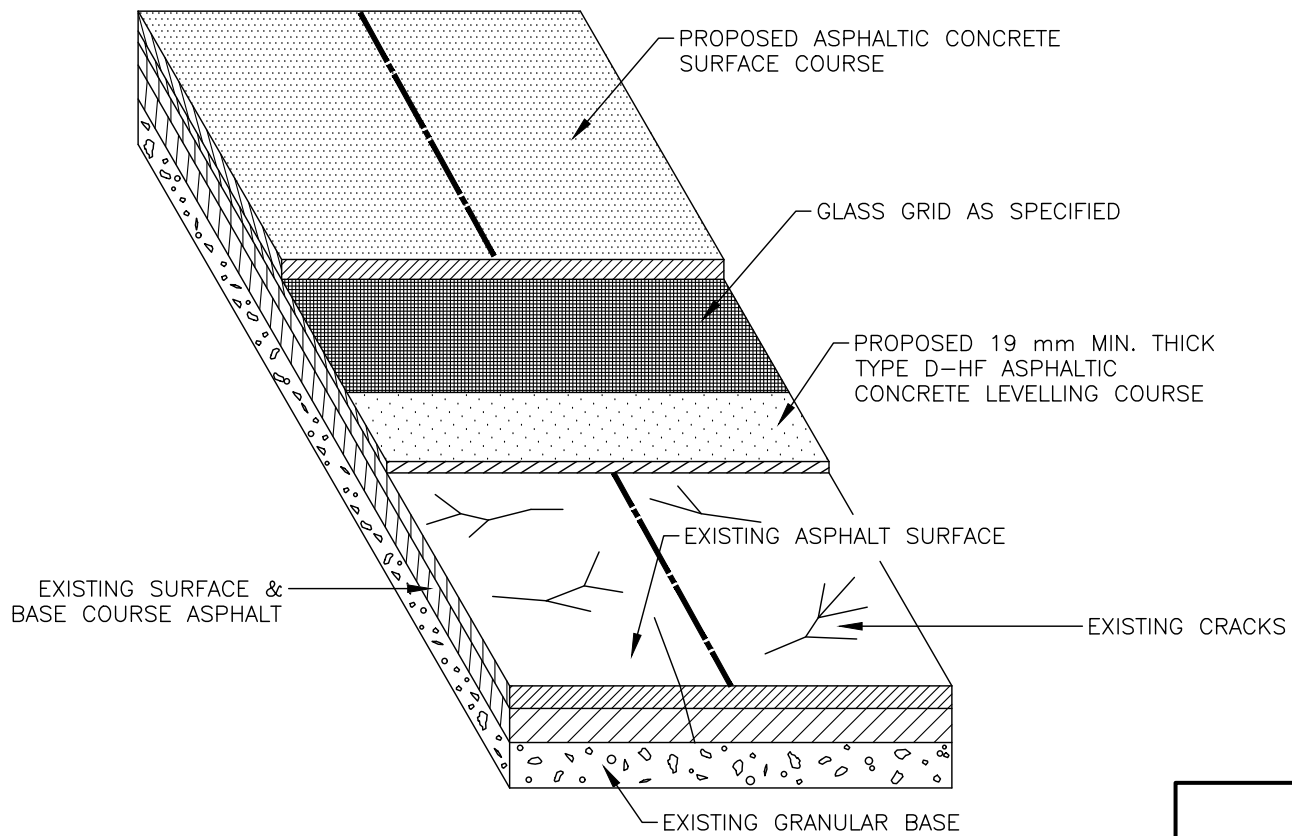

HALIFAX

STANDARD DETAIL

GLASS GRID INSTALLATION

DATE:	2021	REFERENCE	APPROVED
SCALE:	NTS		FIG No.: HRM 29

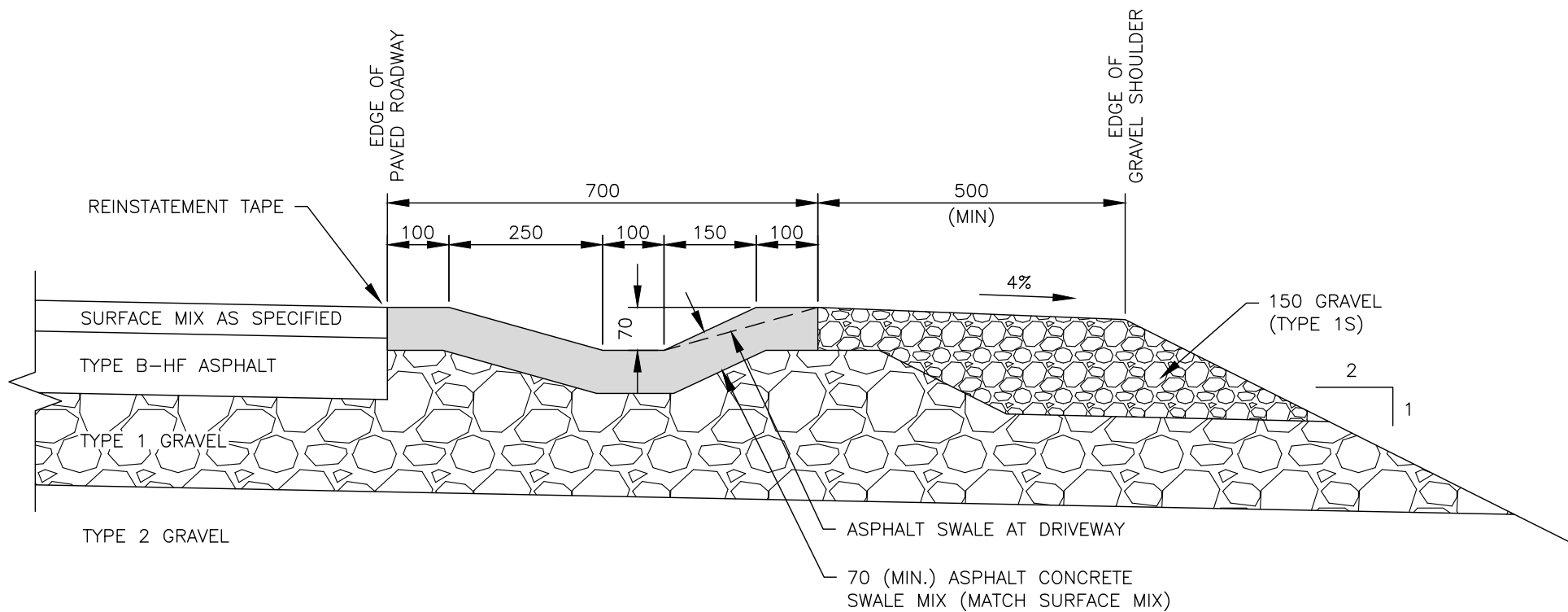

NOTE:

1. FOR ALL RURAL ROADS HAVING A GRADE EXCEEDING 7%, ASPHALT SWALES ARE REQUIRED ON EACH SIDE OF THE ROAD (ABUTTING THE ASPHALT TRAVELLED WAY) ASPHALT SWALE RUNOFF TO THE DITCH EVERY 30m OR UPSTREAM AT DRIVEWAYS.
2. ASPHALT SWALE SHALL EXTEND TO THE EDGE OF SHOULDER AND DOWN THE SLOPE BY 1 m MINIMUM.
3. MINIMUM SWALE CROSSFALL TO MATCH THE EXISTING SLOPE OF THE ROAD.
4. ASPHALT SWALE TO BE MACHINE PLACED.
5. 1 m ASPHALT APRON REQUIRED AT GRAVEL DRIVEWAYS.
6. DIMENSIONS ARE IN MILLIMETRES.

HALIFAX		
STANDARD DETAIL		
ASPHALT SWALE		
DATE: 2021	REFERENCE	APPROVED
SCALE: 1:10		FIG No.: HRM 30

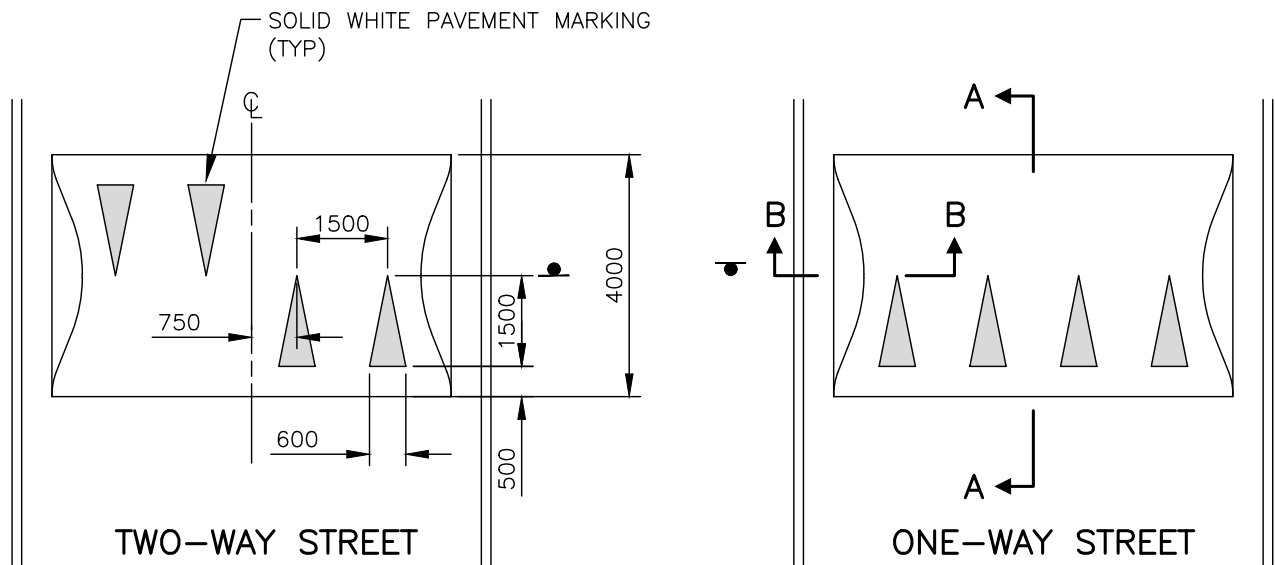

SPEED HUMPS
SCALE: 1:125

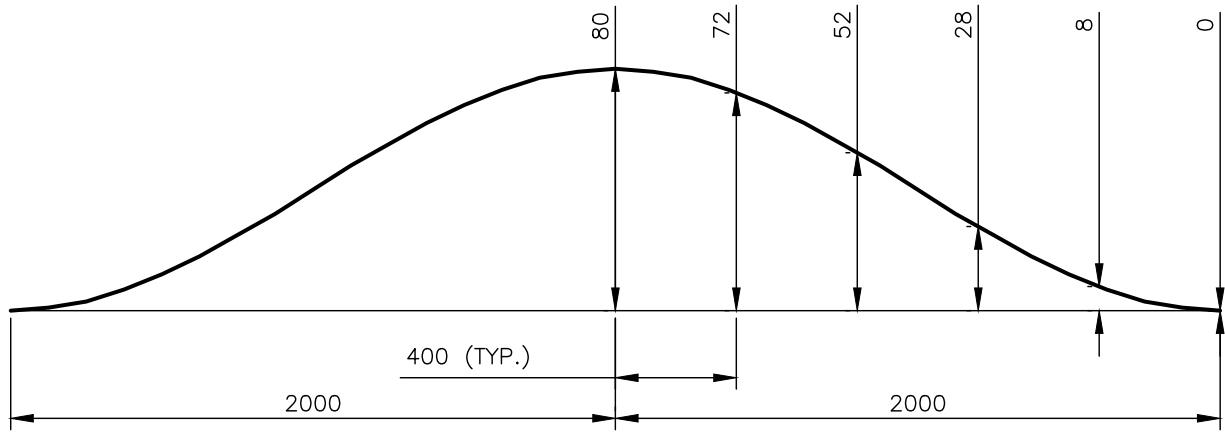

SECTION A-A
SCALE: HORZ. 1:25
VERT. 1:2.5

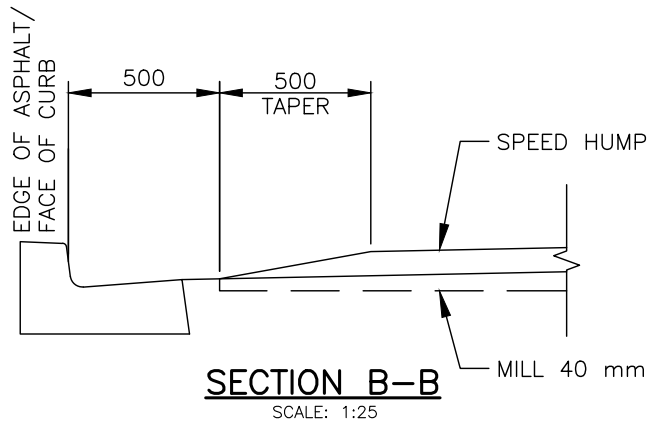

SECTION B-B
SCALE: 1:25

NOTES:

1. TOLERANCE FOR CONSTRUCTION IS +/- 10 mm RELATIVE TO THE CURVE.
2. THE EXISTING ASPHALT SURFACE TO BE MILLED TO A DEPTH OF 40 mm WHEN RETROFITTING.
3. DIMENSIONS ARE IN MILLIMETRES.

HALIFAX		
STANDARD DETAIL		
SPEED HUMP		
DATE: 2021	REFERENCE	APPROVED
SCALE: AS NOTED		FIG No.: HRM 31

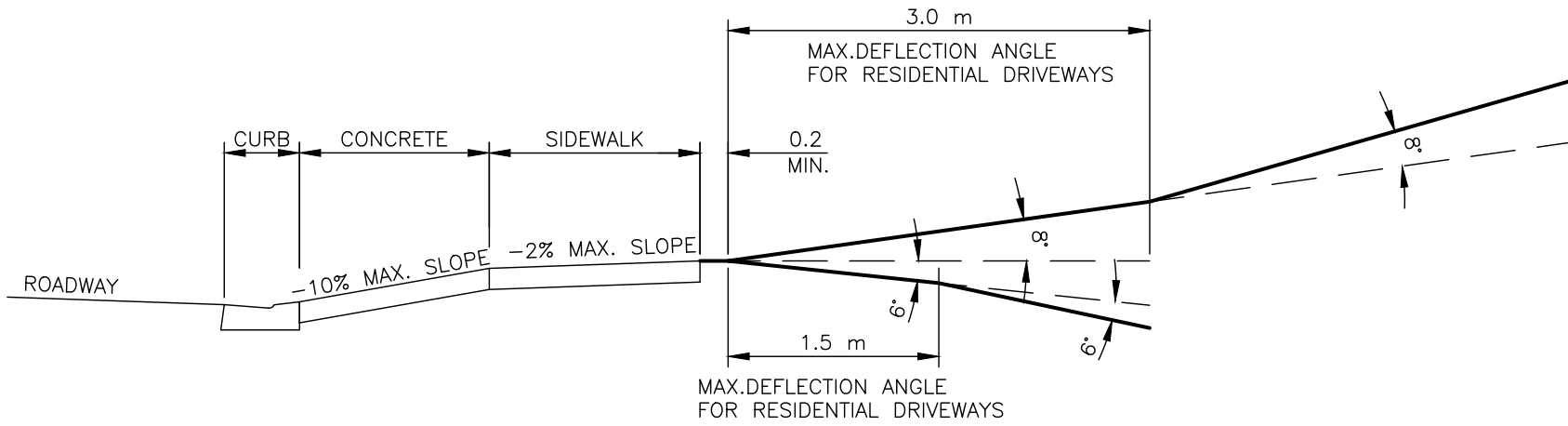

SECTION A-A

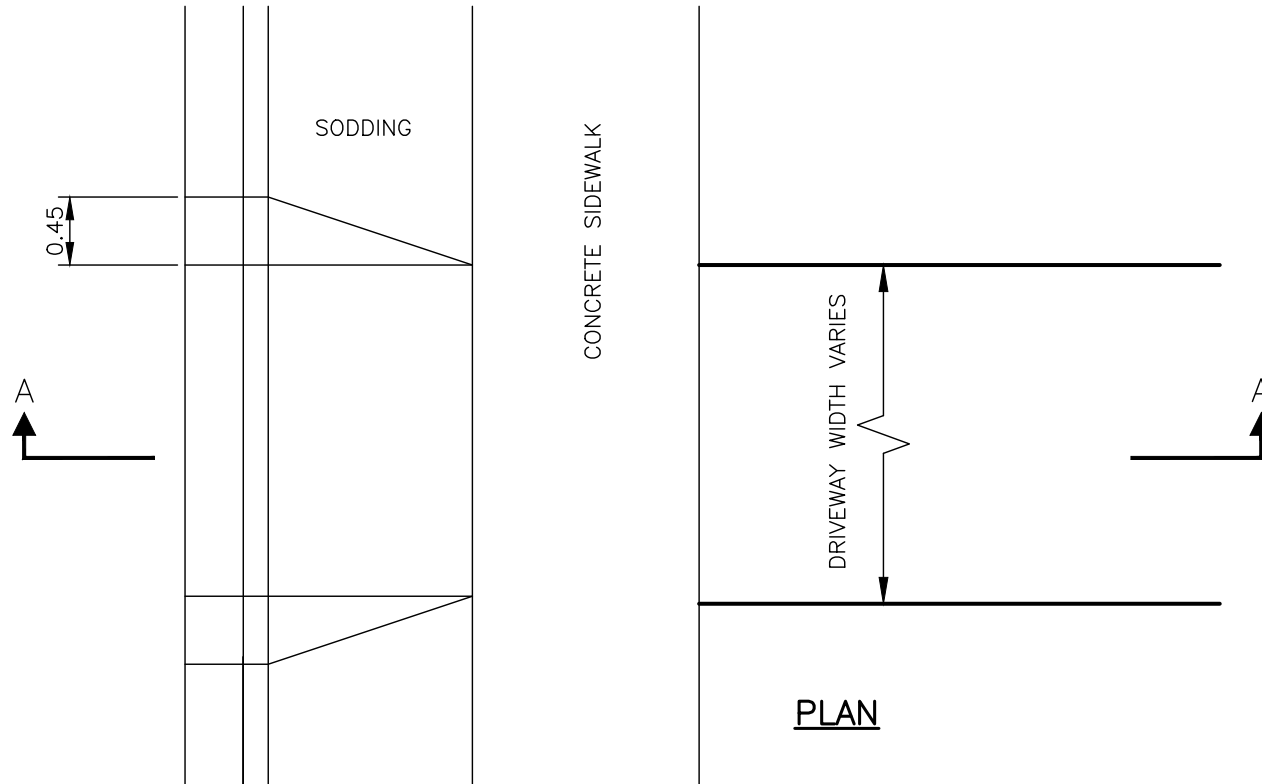

NOTE:

THIS DETAIL IS INTENDED FOR RETROFIT SITUATIONS, I.E. WHERE EXISTING DRIVEWAY GRADES MUST BE ADJUSTED TO MATCH NEW CONDITIONS IN THE STREET RIGHT-OF-WAY.

HALIFAX

STANDARD DETAIL

DRIVEWAY DEFLECTION ANGLES & GRADES

DATE:	2021	REFERENCE	APPROVED
SCALE:	1:50		FIG No.: HRM 32

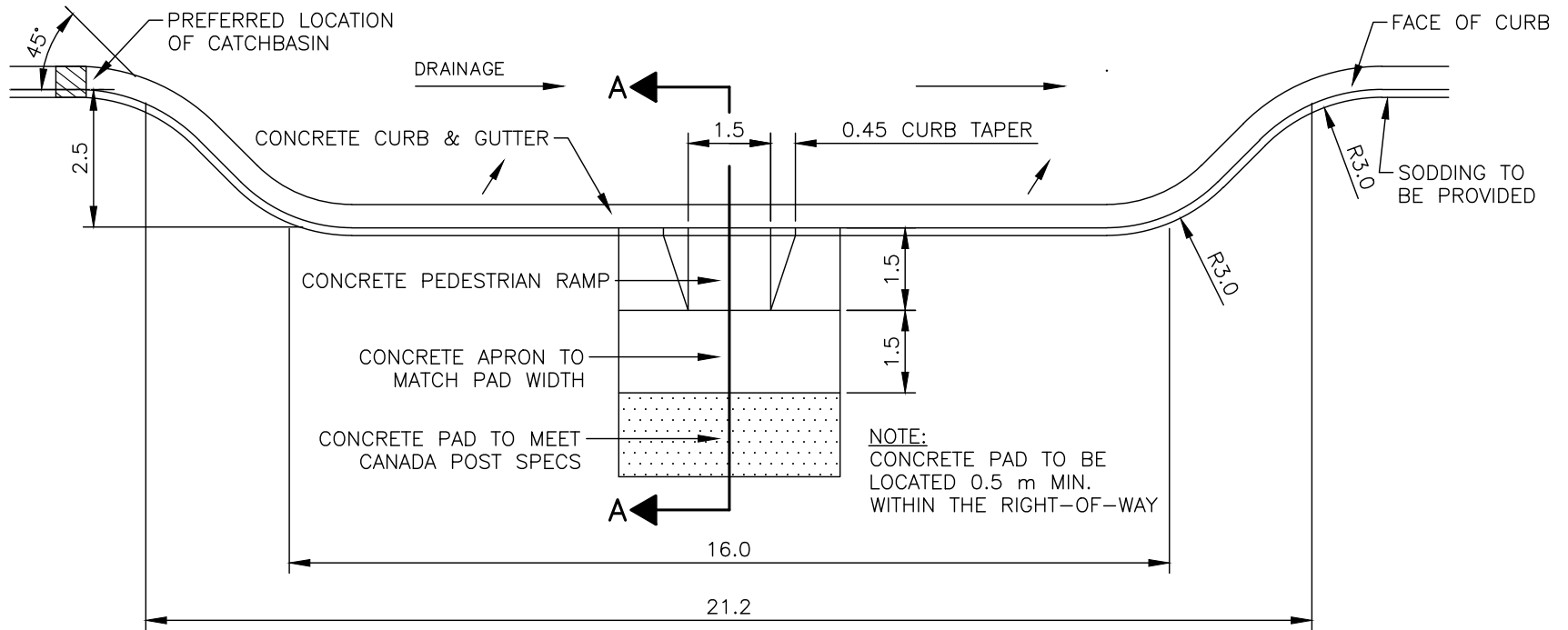

NOTE: NOT TO BE USED ON LOCAL URBAN ROADS.

PLAN
SCALE 1:125

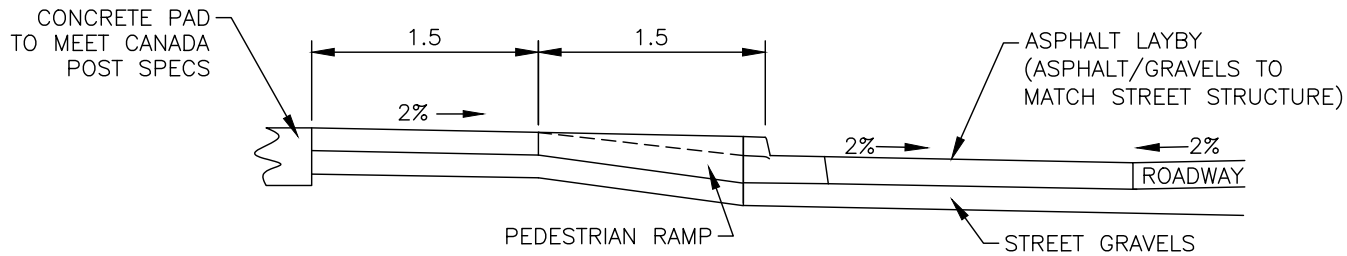

SECTION A-A
SCALE 1:50

HALIFAX

STANDARD DETAIL

**COMMUNITY MAILBOX –
URBAN ROAD WITHOUT SIDEWALK**

DATE:	2021	REFERENCE	APPROVED
SCALE:	AS NOTED		FIG No.:
			HRM 33

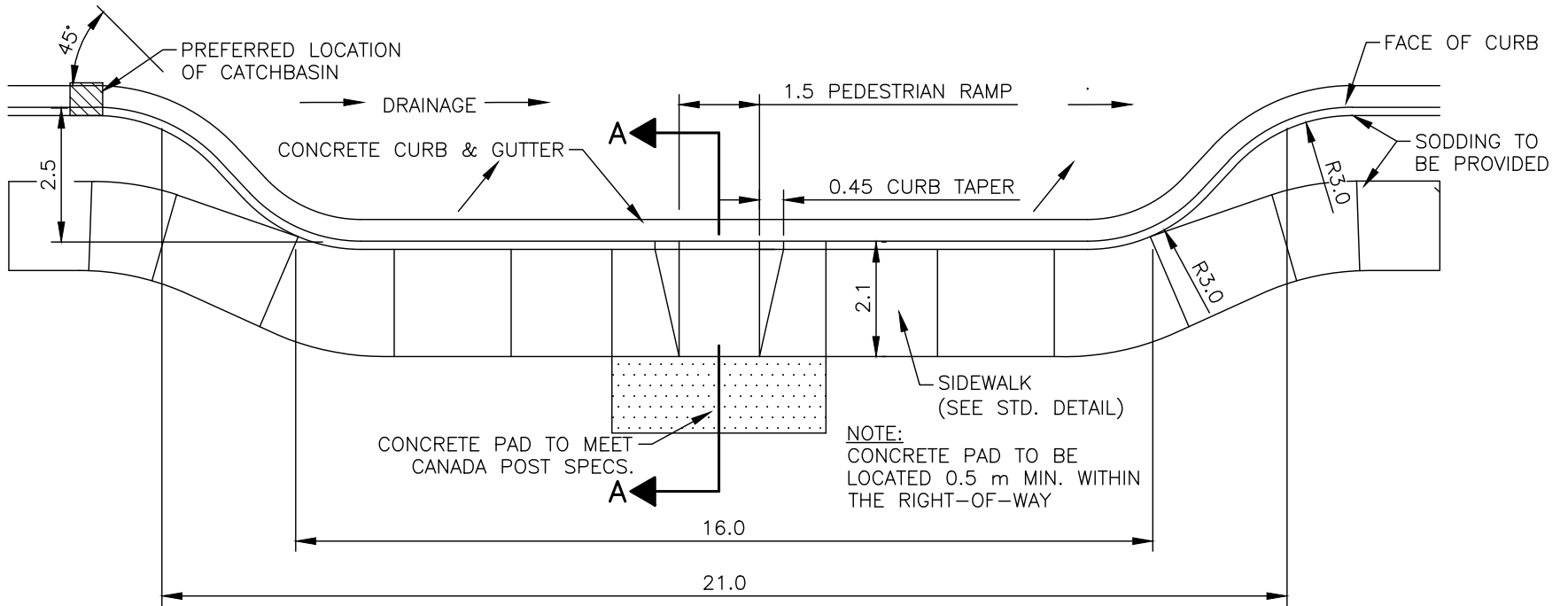

NOTE: NOT TO BE USED ON LOCAL URBAN ROADS.

PLAN
SCALE 1:125

NOTE:
CONTROL JOINTS OF SIDEWALK TO
BE IN LINE WITH THOSE OF CURB
WHEREVER POSSIBLE

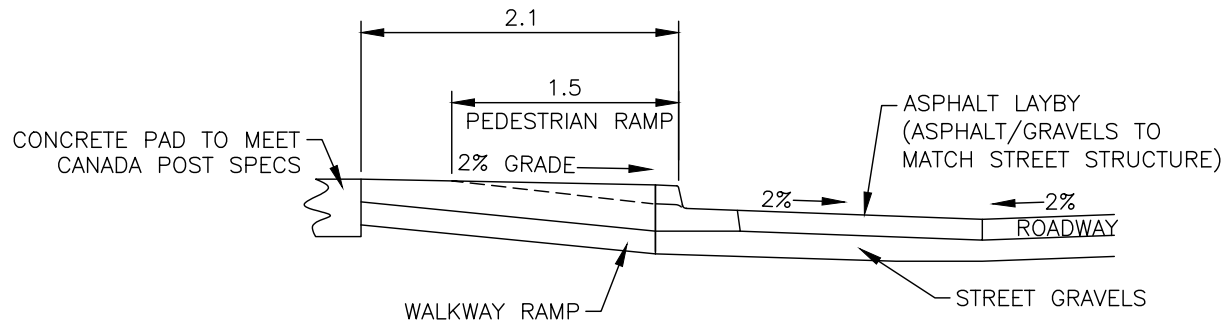

SECTION A-A
SCALE 1:50

HALIFAX

STANDARD DETAIL

**COMMUNITY MAILBOX –
URBAN ROAD WITH SIDEWALK**

DATE:	2021	REFERENCE	APPROVED
SCALE:	AS NOTED	FIG No.:	HRM 34

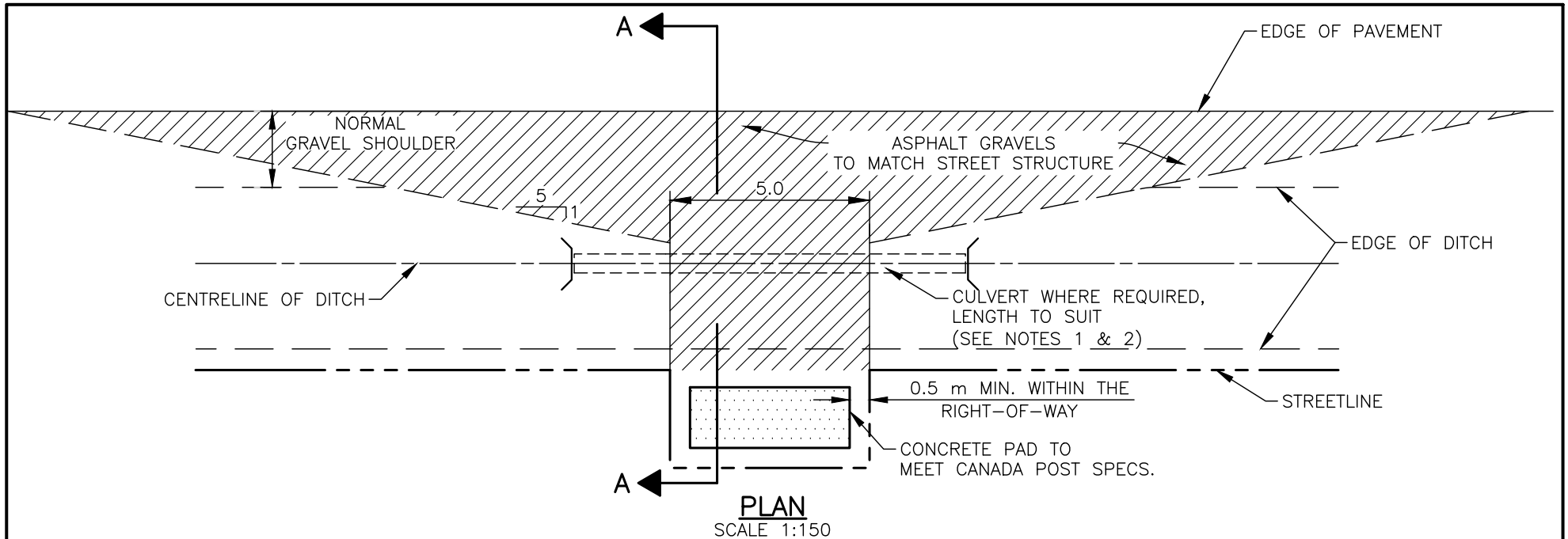

NOTES:

1. CULVERT SHALL BE INSTALLED WITH PRECAST CONCRETE DRIVEWAY HEADWALLS AS PER HALIFAX WATER GUIDELINES.
2. CULVERT DIAMETER AS PER DESIGN AND SHALL NOT BE SMALLER THAN 450 mm IN DIAMETER NOR SMALLER THAN ANY UPSTREAM CULVERT.

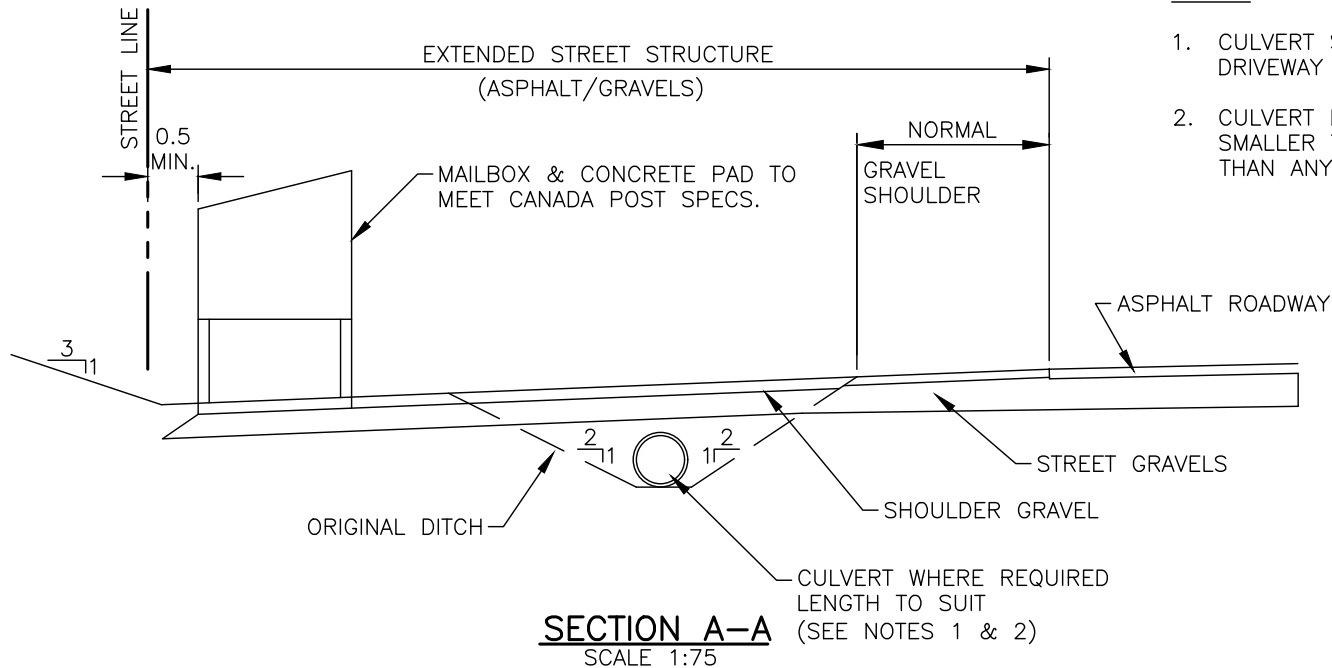

HALIFAX		
STANDARD DETAIL		
COMMUNITY MAILBOX— RURAL ROAD LAYBY		
DATE:	REFERENCE	APPROVED
2021		
SCALE:		FIG No.:
AS NOTED		HRM 35

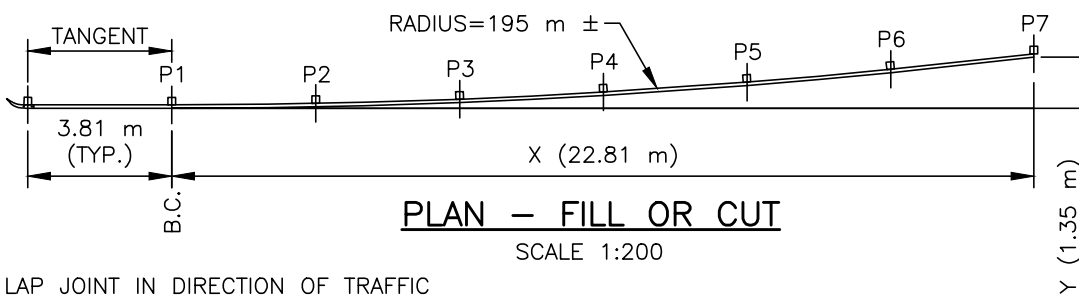

POST OFFSET TABLE		
POST #	X	Y
P1-P2	3.81	0.04
P1-P3	7.62	0.15
P1-P4	11.42	0.34
P1-P5	15.22	0.60
P1-P6	19.02	0.94
P1-P7	22.81	1.35

PLAN – FILL OR CUT
SCALE 1:200

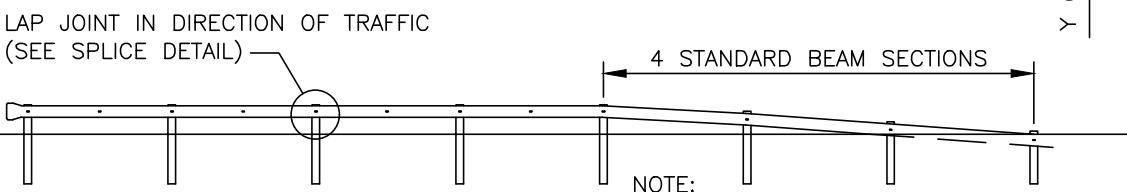

ELEVATION
SCALE 1:200

NOTE:
FOR 2 LANE/2 WAY ROADWAYS,
BURY BOTH ENDS.

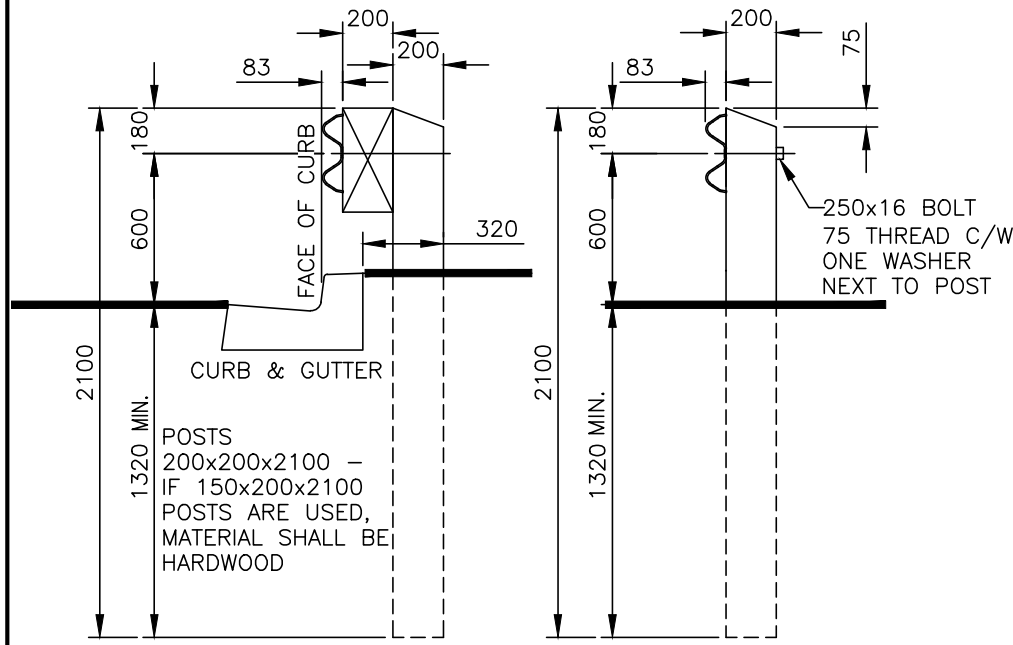

SECTION
SCALE 1:30

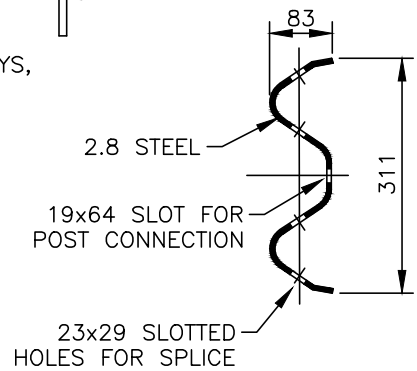

BEAM SECTION (TYP.)
SCALE 1:10

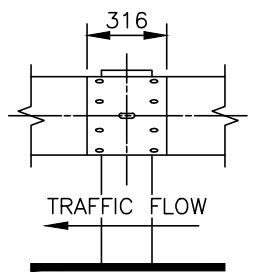

SPLICE DETAIL
SCALE 1:30

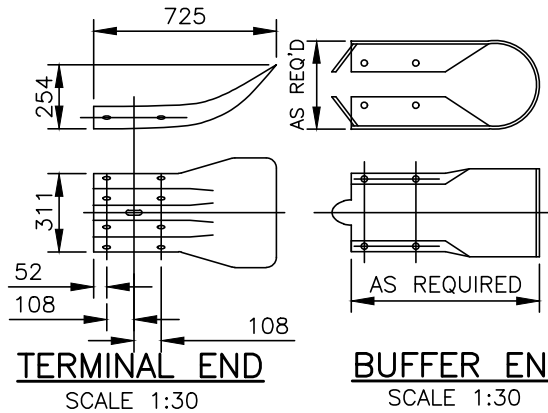

TERMINAL END
SCALE 1:30

BUFFER END
SCALE 1:30

NOTES:

1. TWO 50x75 DELINEATORS ARE REQUIRED FOR EACH POST.
2. A WHITE DELINEATOR SHALL BE PLACED ON THE SIDE OF THE POST FACING TRAFFIC.
3. A YELLOW DELINEATOR SHALL BE PLACED ON THE OPPOSITE SIDE.
4. THE DELINEATOR SHALL BE PLACED ON THE OPPOSITE SIDE.
5. THE DELINEATOR SHALL BE LOCATED AT THE EDGE OF THE POST NEAREST THE ROAD, VERTICAL, WITH THE TOP 75 BELOW THE LOWEST POINT OF THE GUIDE RAIL PANEL.
6. THE DELINEATOR SHALL BE ATTACHED WITH GALVANIZED NAILS.

HALIFAX

STANDARD DETAIL

GUIDE RAIL
INSTALLATION

DATE:	REFERENCE	APPROVED
2021		
SCALE:		FIG No.:
AS NOTED		HRM 36

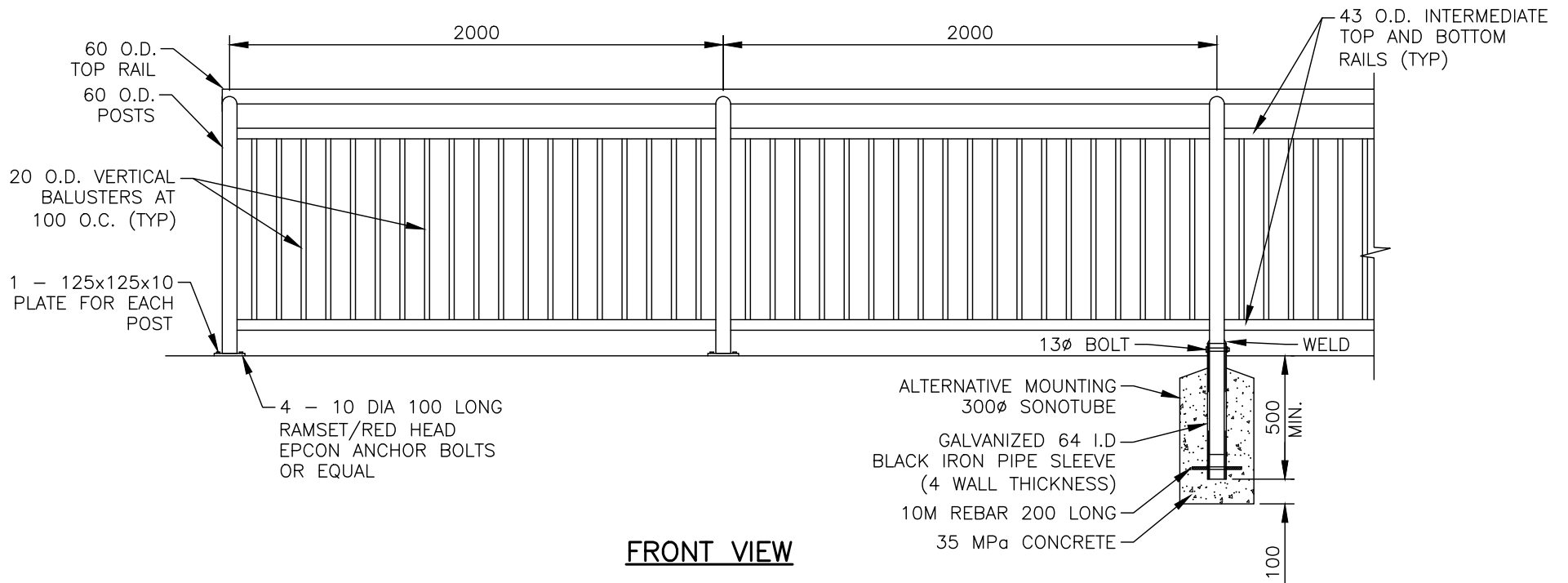

FRONT VIEW

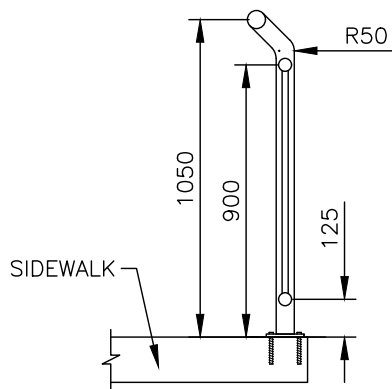

SIDE VIEW

NOTE:

RAILING SYSTEM TO BE HOT DIPPED GALVANIZED AFTER FABRICATION. FIELD WELDS, IF NECESSARY SHALL BE PROTECTED WITH COLD GALVANIZING.

HALIFAX

STANDARD DETAIL

RAILING

DATE:	2021	REFERENCE	APPROVED
SCALE:	1:25		FIG No.: HRM 37

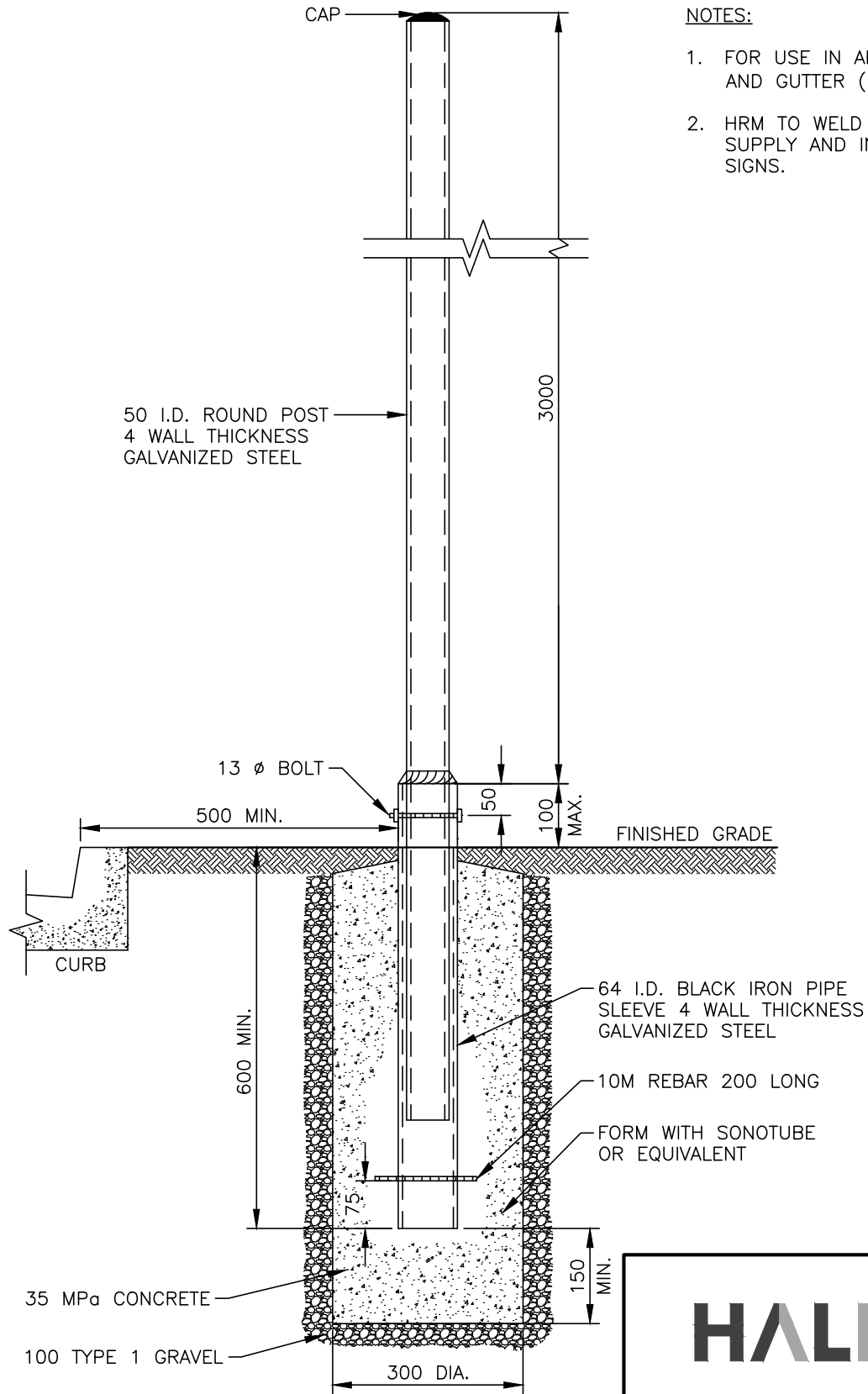

NOTES:

1. FOR USE IN AREAS WITH CURB AND GUTTER (URBAN LOCATIONS)
2. HRM TO WELD THE POST AND SUPPLY AND INSTALL APPROPRIATE SIGNS.

HALIFAX

STANDARD DETAIL

URBAN TRAFFIC SIGN POST

DATE:	2021	REFERENCE	APPROVED
SCALE:	1:10		FIG No.: HRM 38

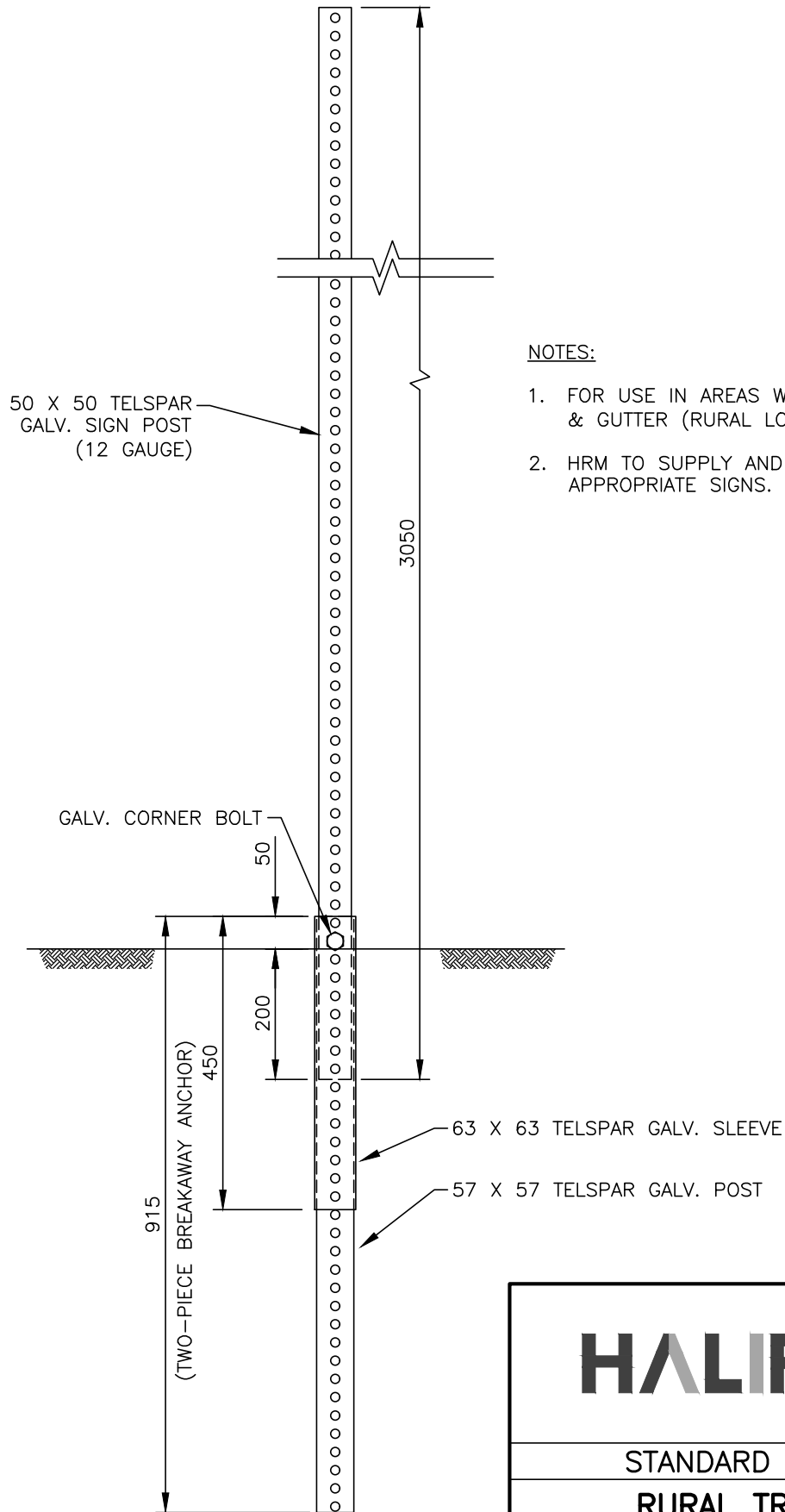

NOTES:

1. FOR USE IN AREAS WITHOUT CURB & GUTTER (RURAL LOCATIONS).
2. HRM TO SUPPLY AND INSTALL APPROPRIATE SIGNS.

HALIFAX

STANDARD DETAIL

**RURAL TRAFFIC
SIGN POST**

DATE:	2021	REFERENCE	APPROVED
SCALE:	1:10		FIG No.: HRM 39

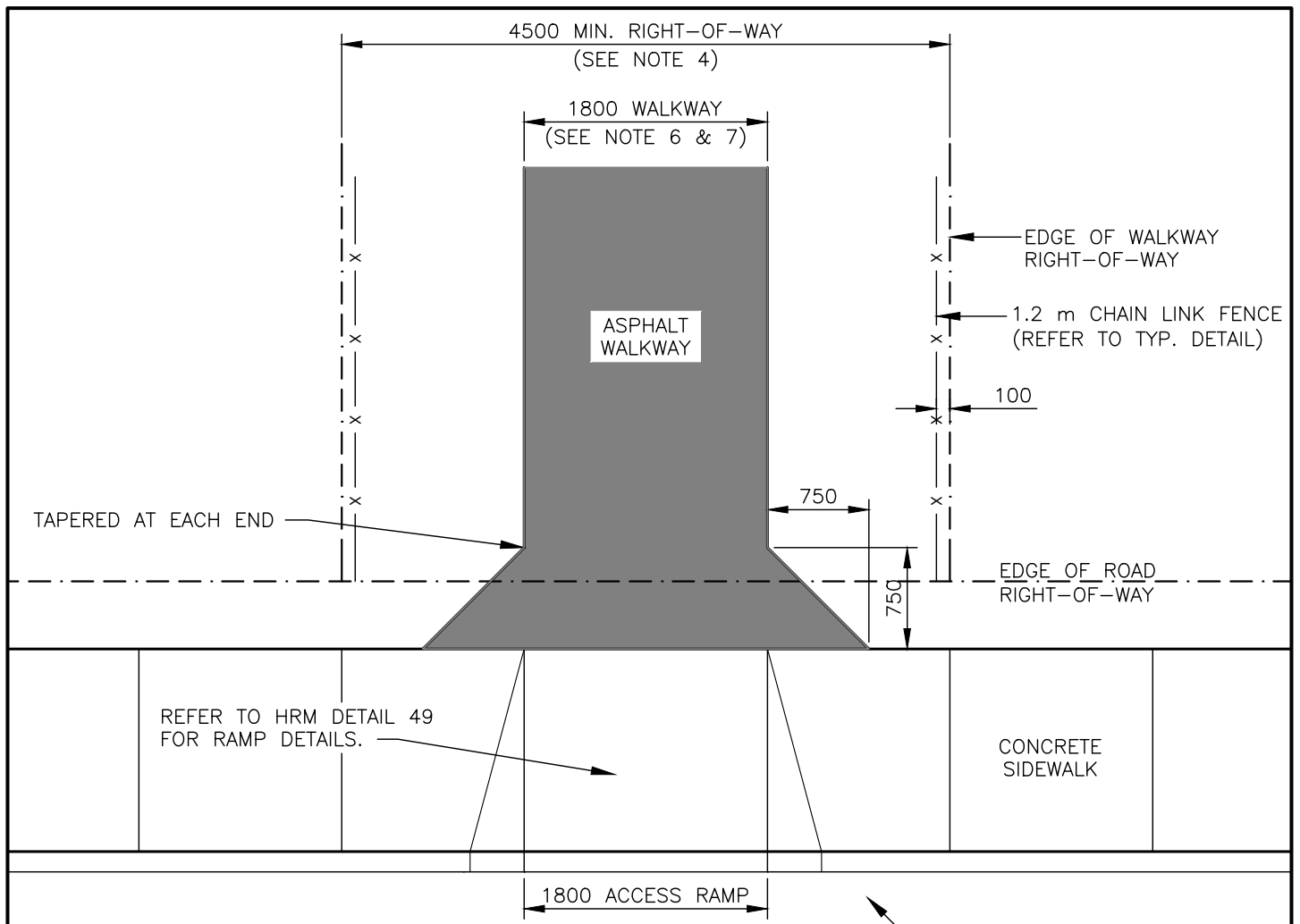

PLAN

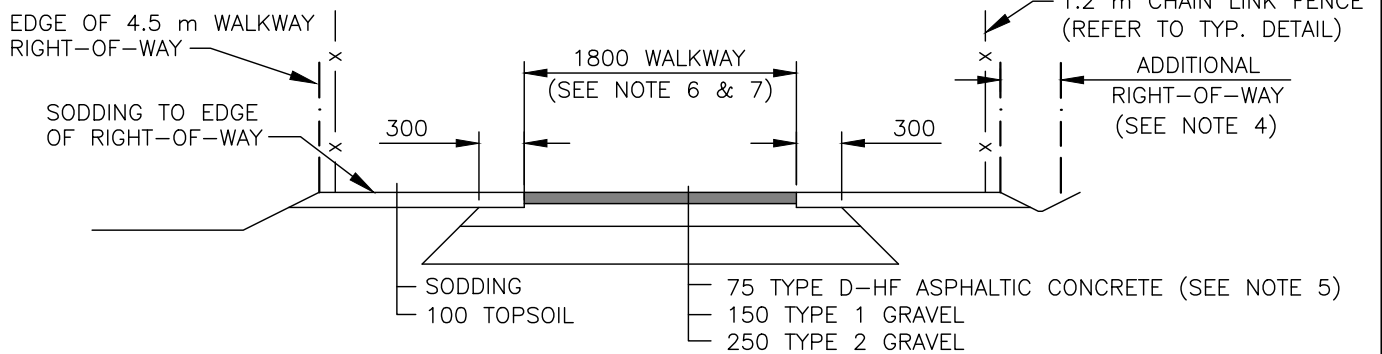

PROFILE

NOTES:

1. WALKWAY SHOULD HAVE MIN. CONSISTENT GRADE OF 2.0% WHERE POSSIBLE.
2. THE ENGINEER MAY REQUIRE OR PERMIT USE OF LOW MAINTENANCE MATERIALS IN PLACE OF SODDING.
3. WHERE MUNICIPAL SERVICE SYSTEMS ARE REQUIRED THE MIN. R.O.W. IS TO BE INCREASED TO 6.0 m. THE CHAIN LINK FENCE SHALL BE LOCATED 100 FROM THE EDGE OF THE INCREASED 6.0 m R.O.W..
4. TO ACCOMMODATE SWALE OR CUT/FILL SLOPES ADDITIONAL RIGHT-OF-WAY MAY BE REQUIRED.
5. SURFACE MATERIAL TO BE ASPHALTIC CONCRETE UNLESS DIRECTED BY THE ENGINEER.
6. GRADE AS DIRECTED BY THE ENGINEER.
7. TO BE PLACED WITH SPREADER.

HALIFAX

STANDARD DETAIL

TYPICAL WALKWAY

DATE:	2021	REFERENCE	APPROVED
SCALE:	1:50	FIG No.:	HRM 40

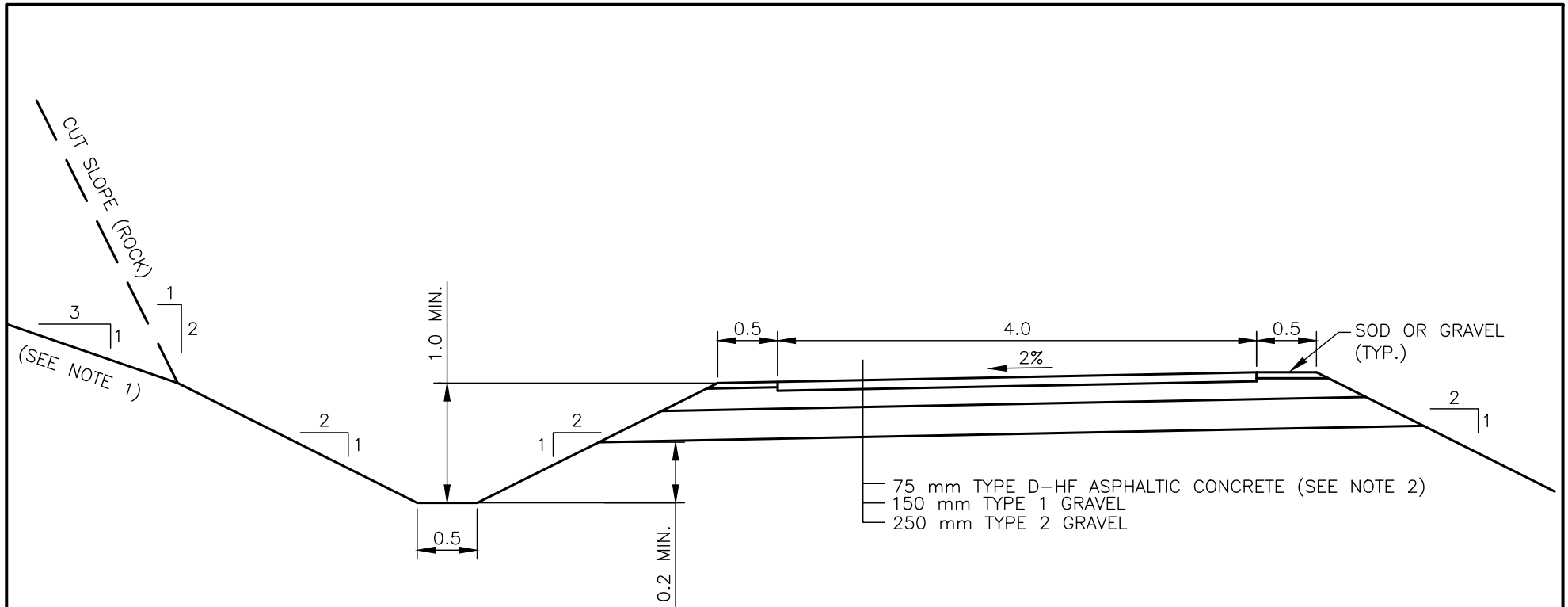

— 75 mm TYPE D-HF ASPHALTIC CONCRETE (SEE NOTE 2)
 — 150 mm TYPE 1 GRAVEL
 — 250 mm TYPE 2 GRAVEL

NOTES:

1. ADDITIONAL SLOPE STABILIZATION AS PER GEOTECHNICAL REPORT.
2. SURFACE MATERIAL TO BE ASPHALTIC CONCRETE UNLESS DIRECTED BY THE ENGINEER.
3. RAILING REQUIRED IN FILL GREATER THAN 1.5 m, OR ADJACENT TO WATER.
4. FALSE DITCH REQUIREMENTS SHALL MEET HALIFAX WATER SPECIFICATIONS.

<h1>HALIFAX</h1>		
STANDARD DETAIL		
ACTIVE TRANSPORTATION OFF ROAD TRAIL		
DATE:	2021	REFERENCE
SCALE:	1:50	APPROVED
		FIG No.: HRM 41

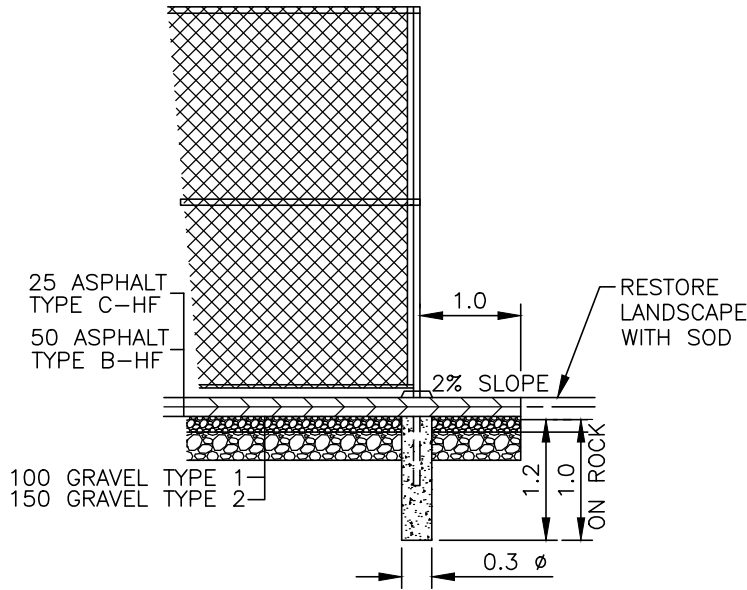

NOTES:

1. 3.0 HIGH CHAIN LINK FENCE FABRIC 37 X 9 GAUGE STEEL GALVANIZED WIRE FENCE KNUCKLED TOP AND BOTTOM.
2. CORNER POSTS 87 O.D. GALVANIZED STEEL PIPE.
3. LINE POST 60 O.D. GALVANIZED STEEL PIPE.
4. RAILING TOP, BOTTOM AND CENTRE RAILS TO BE 42 O.D. GALVANIZED STEEL PIPE.
5. MAXIMUM SPACING OF POST TO BE 3.0.

TYPE I COURT FENCE

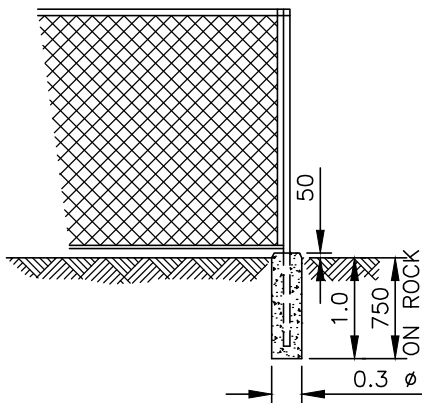

NOTES:

1. 1.8 m HIGH CHAIN LINK FENCE FABRIC 50 mm X 9 mm GAUGE STEEL GALVANIZED WIRE FENCE KNUCKLED ON TOP.
2. CORNER POSTS 87 mm O.D. GALVANIZED STEEL PIPE.
3. LINE POST 60 mm O.D. GALVANIZED STEEL PIPE.
4. RAILING 42 mm O.D. GALVANIZED STEEL PIPE.
5. GROUND WIRE 2 STRANDS 6 GAUGE GALVANIZED STEEL WIRE.
6. MAXIMUM SPACING OF POSTS TO BE 2.4.
7. PLACE FABRIC ON SIDE OF FENCE WITH MOST PEDESTRIAN TRAFFIC, UNLESS OTHERWISE NOTED.

TYPE II BOUNDARY FENCE

GENERAL NOTES:

1. FOR ALL FENCE TYPES STEEL PIPE TO BE "STANDARD WEIGHT" (SCHEDULE 40) UNLESS OTHERWISE NOTED.
2. ALL CONCRETE TO BE 30 MPa COMPRESSIVE STRENGTH, MAXIMUM AGGREGATE SIZE OF 20 AND 5% TO 8% AIR CONTENT.
3. CONCRETE BASE TO BE FORMED WITH SONOTUBE OR EQUIVALENT.
4. NO TOP RAIL BESIDE OR ON ROAD.

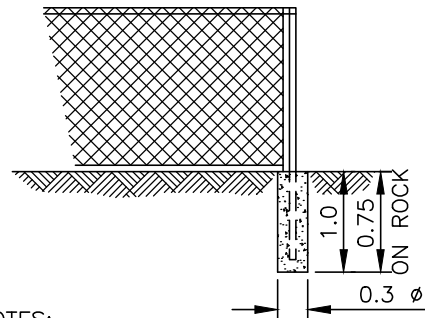

NOTES:

1. 1.0 AND 1.2 HIGH CHAIN LINK FENCE FABRIC 50 X 9 GAUGE STEEL GALVANIZED WIRE FENCE KNUCKLED ON TOP.
2. CORNER POSTS 87 O.D. GALVANIZED STEEL PIPE.
3. LINE POSTS 60 O.D. GALVANIZED STEEL PIPE.
4. RAILING 42 O.D. GALVANIZED STEEL PIPE.
5. GROUND WIRE 2 STRANDS 6 GAUGE GALVANIZED STEEL WIRE.
6. MAXIMUM SPACING OF POSTS TO BE 2.4.

TYPE III SAFETY FENCE

NOTES:

- FOR 3.7 HIGH CHAIN LINK FENCE TYPE IV
1. CORNER & GATE POSTS 100 O.D. GALVANIZED STEEL PIPE.
 2. LINE POSTS 60 O.D. GALVANIZED STEEL PIPE.
 3. ALL OTHER FEATURES AS PER 3.0 HIGH CHAIN LINK FENCE.

TYPE IV COURT FENCE

HALIFAX

STANDARD DETAIL

CHAIN LINK FENCE

DATE:	2021	REFERENCE	APPROVED
SCALE:	1:75		FIG No.: HRM 42

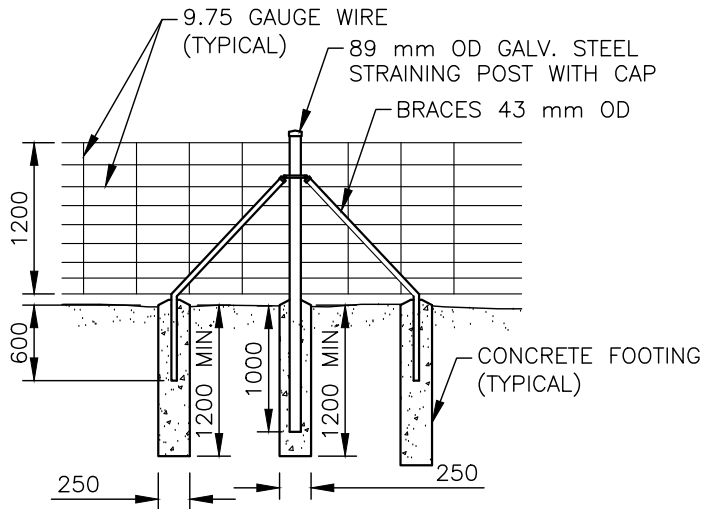

STRAINING POST
EVERY 150 m
SCALE: 1:60

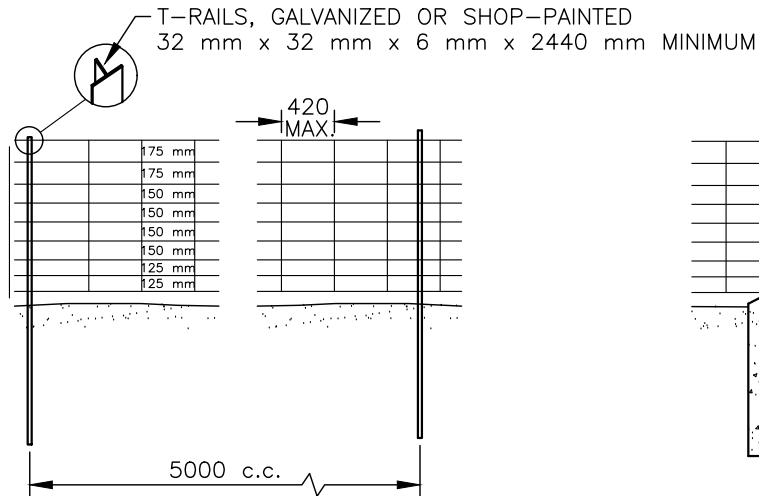

T-RAIL
LINE POSTS
SCALE: 1:60

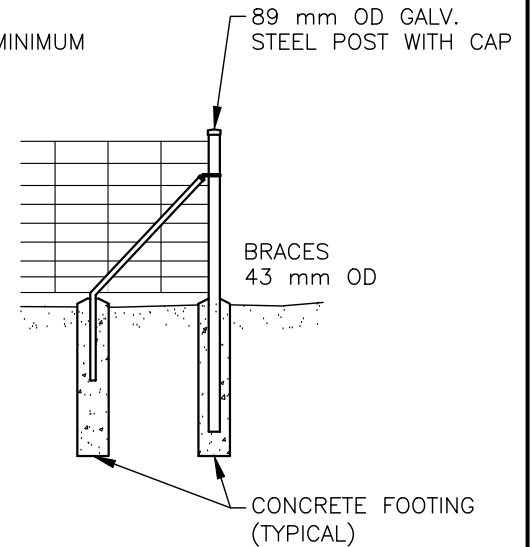

END OR CORNER POST
AND BRACE
SCALE: 1:60

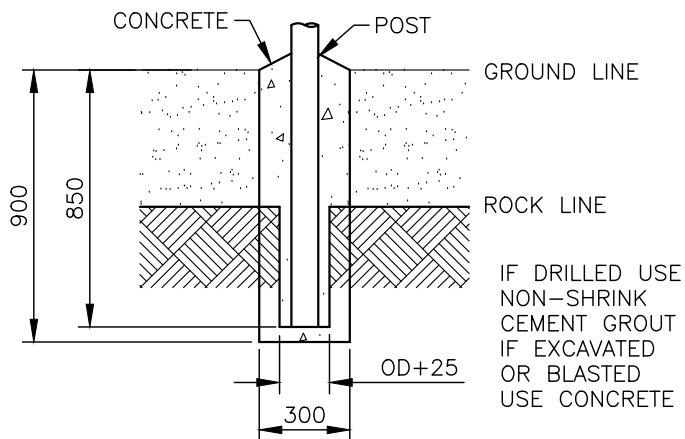

IN SHALE OR FRIABLE ROCK, AND IN SOLID
ROCK WITH MORE THAN 450 mm OVERBURDEN

SCALE: 1:25

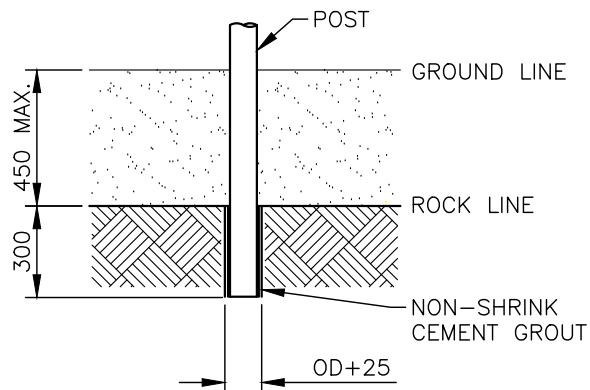

IN SOLID ROCK WITH OVERBURDEN
LESS THAN 450 mm

SCALE: 1:25

HALIFAX

STANDARD DETAIL

PAGE WIRE FENCE

DATE:	2021	REFERENCE	APPROVED
SCALE:	AS NOTED	FIG No.:	HRM 43

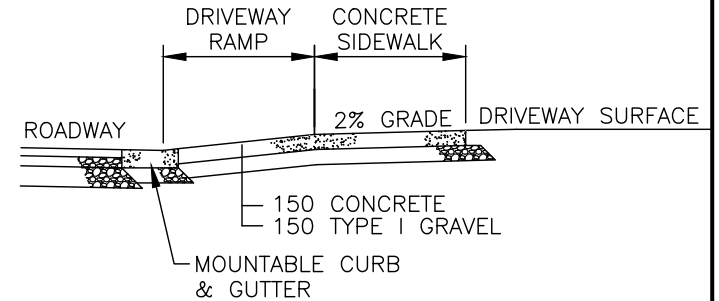
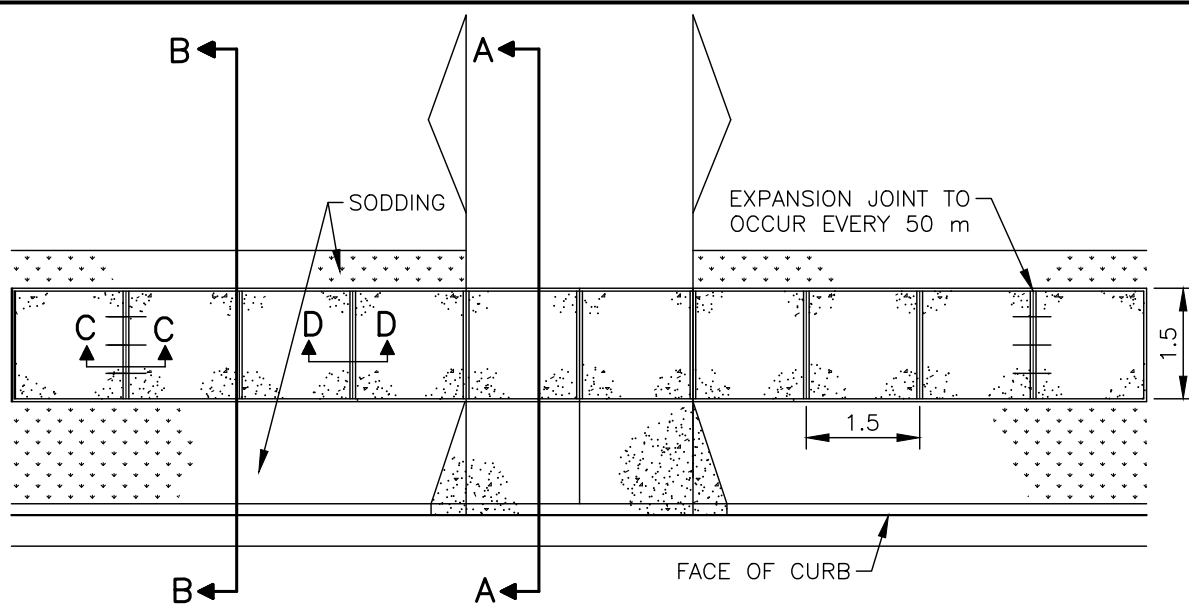

SECTION A-A
(DRIVEWAY CROSS-SECTION)

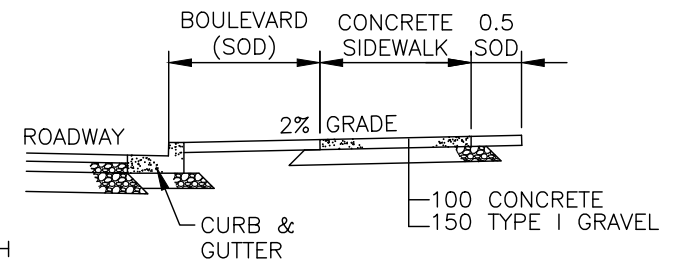

SECTION B-B
(SIDEWALK CROSS-SECTION)

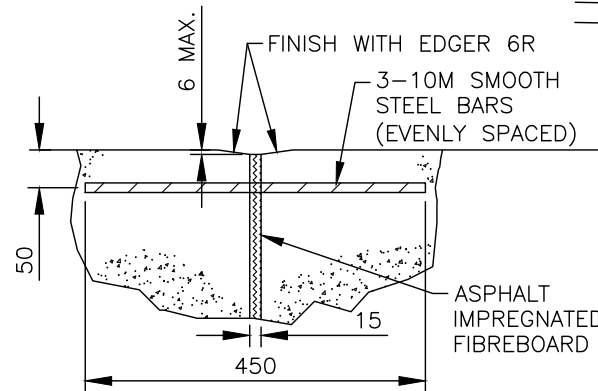

SECTION C-C
(EXPANSION JOINT)

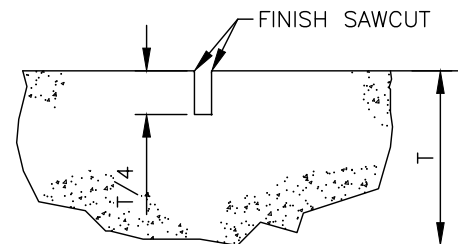

SECTION D-D
(CONTROL JOINT)

NOTES:

1. CONCRETE SIDEWALK AT COMMERCIAL DRIVEWAY TO BE 150 THICK WITH 150x150 WELDED WIRE MESH.
2. CRUSHED ROCK BASE TO EXTEND 150 BEYOND EDGE OF SIDEWALK STRUCTURE.
3. CONTROL JOINTS ARE TO BE SAW CUT.
4. SIDEWALK ABUTTING HIGH DENSITY AREAS SHALL HAVE FULL WIDTH (3 m) SIDEWALKS.
5. SIDEWALKS ABUTTING COMMERCIAL AREAS ARE TO BE FULL WIDTH (3 m) AND 150 mm THICKNESS.
6. EXPANSION JOINT BARS ARE TO BE GREASED ON ONE SIDE OF THE JOINT.
7. DURING CONSECUTIVE POURS, THE END OF EACH POUR IS TO OCCUR AT AN EXPANSION JOINT. WHERE THIS IS NOT FEASIBLE, AN ADDITIONAL EXPANSION JOINT IS TO BE INSTALLED.
8. INSTALL A 9 m LONG CONCRETE LANDING PAD AT ALL BUS STOP LOCATIONS. INCREASE THIS TO 14.5 m FOR ARTICULATED BUS ROUTES.
9. WHEN BOULEVARD IS LESS THAN 1.5 m OR WHEN THE SIDEWALK ABUTS THE CURB & GUTTER, REFER TO HRM 133.
10. SEE HRM 48 FOR SIDEWALK WITHIN 6 m OF TREES.

HALIFAX

STANDARD DETAIL

URBAN SIDEWALK

DATE: 2021	REFERENCE	APPROVED
SCALE: NTS		FIG No.: HRM 44

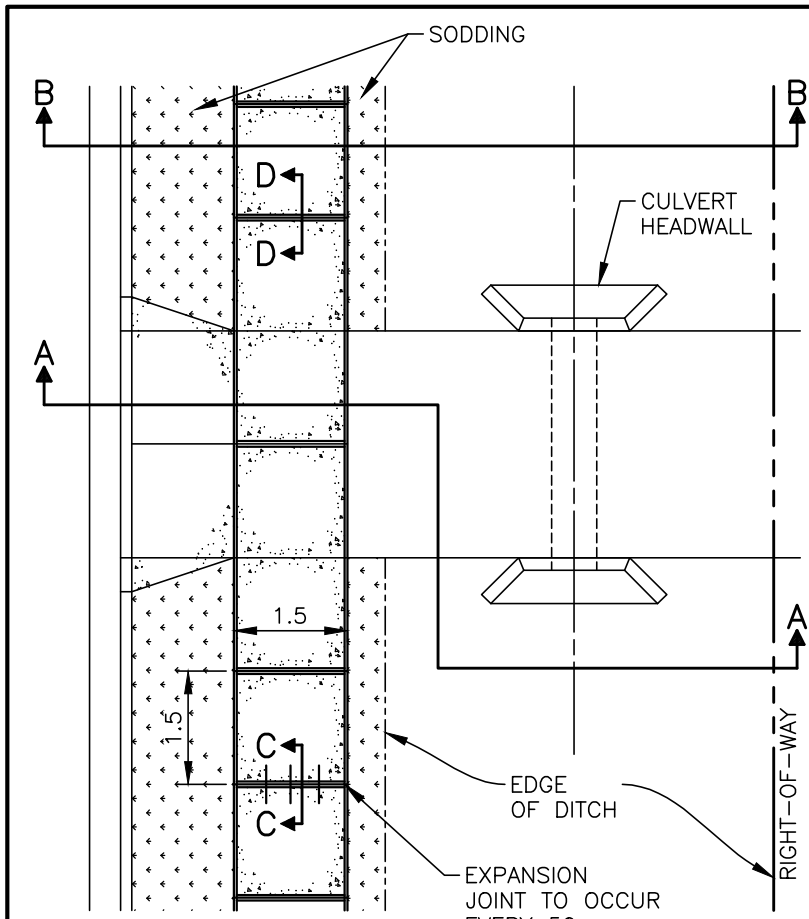

PLAN

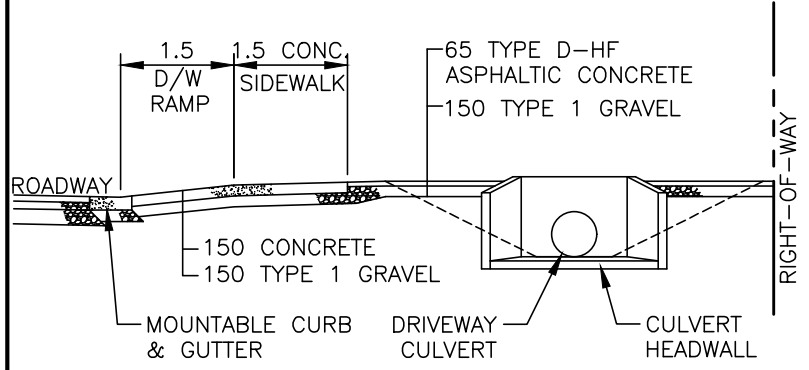

SECTION A-A
(DRIVEWAY CROSS-SECTION)

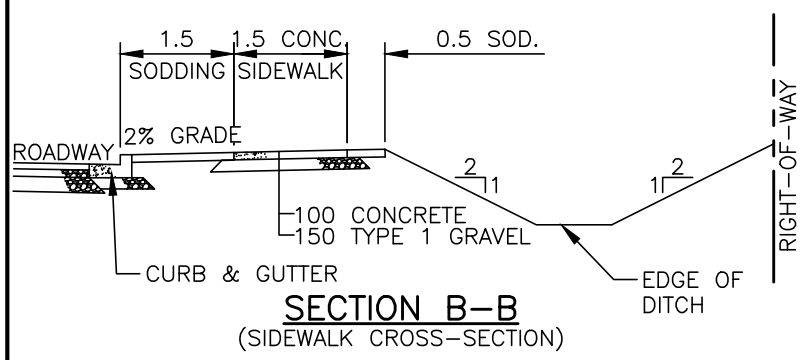

SECTION B-B
(SIDEWALK CROSS-SECTION)

NOTES:

1. CONCRETE SIDEWALK AT COMMERCIAL DRIVEWAY TO BE 150 THICK WITH 150 x 150 WELDED WIRE MESH.
2. CRUSHED ROCK BASE TO EXTEND 150 BEYOND EDGE OF SIDEWALK STRUCTURE.
3. CONTROL JOINTS ARE TO BE SAW CUT.
4. SIDEWALKS ABUTTING COMMERCIAL AREAS ARE TO BE FULL WIDTH (3 m) AND 150 mm THICKNESS.
5. EXPANSION JOINT BARS ARE TO BE GREASED ON ONE SIDE OF THE JOINT.
6. DURING CONSECUTIVE POURS, THE END OF EACH POUR IS TO OCCUR AT AN EXPANSION JOINT. WHERE THIS IS NOT FEASIBLE, AND ADDITIONAL EXPANSION JOINT IS TO BE INSTALLED.
7. INSTALL A 9 m LONG CONCRETE LANDING PAD AT ALL BUS STOP LOCATIONS. INCREASE THIS TO 14.5 m FOR ARTICULATED BUS ROUTES.
8. WHEN BOULEVARD IS LESS THAN 1.5 m OR WHEN THE SIDEWALK ABUTS THE CURB & GUTTER, REFER TO HRM 133.

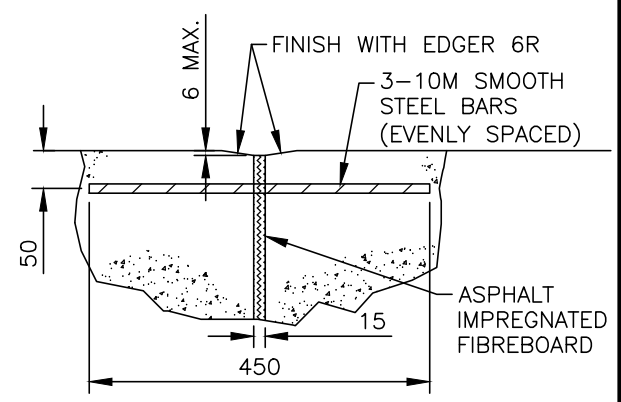

SECTION C-C
(EXPANSION JOINT)

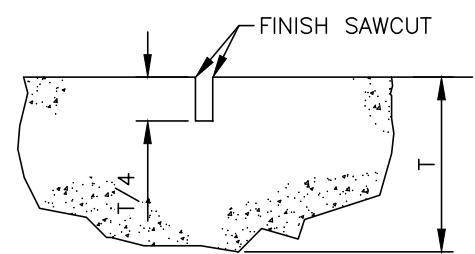

SECTION D-D
(CONTROL JOINT)

HALIFAX

STANDARD DETAIL

**RURAL TYPE I
SIDEWALK**

DATE:	2021	REFERENCE	APPROVED
SCALE:	NTS		FIG No.:
			HRM 45

NOTES:

1. CONCRETE SIDEWALK AT COMMERCIAL DRIVEWAY TO BE 150 THICK WITH 150x150 WELDED WIRE MESH.
2. CRUSHED ROCK BASE TO EXTEND 150 BEYOND EDGE OF SIDEWALK STRUCTURE.
3. CONTROL JOINTS ARE TO BE SAW CUT.
4. SIDEWALKS ABUTTING COMMERCIAL AREAS ARE TO BE FULL WIDTH (3 m) AND 150 mm THICKNESS.
5. EXPANSION JOINT BARS ARE TO BE GREASED ON ONE SIDE OF THE JOINT.
6. DURING CONSECUTIVE POURS, THE END OF EACH POUR IS TO OCCUR AT AN EXPANSION JOINT. WHERE THIS IS NOT FEASIBLE, AN ADDITIONAL EXPANSION JOINT IS TO BE INSTALLED.
7. INSTALL A 9 m LONG CONCRETE LANDING PAD AT ALL BUS STOP LOCATIONS. INCREASE THIS TO 14.5 m FOR ARTICULATED BUS ROUTES.
8. WHEN BOULEVARD IS LESS THAN 1.5 m OR WHEN THE SIDEWALK ABUTS THE CURB & GUTTER, REFER TO HRM 133.

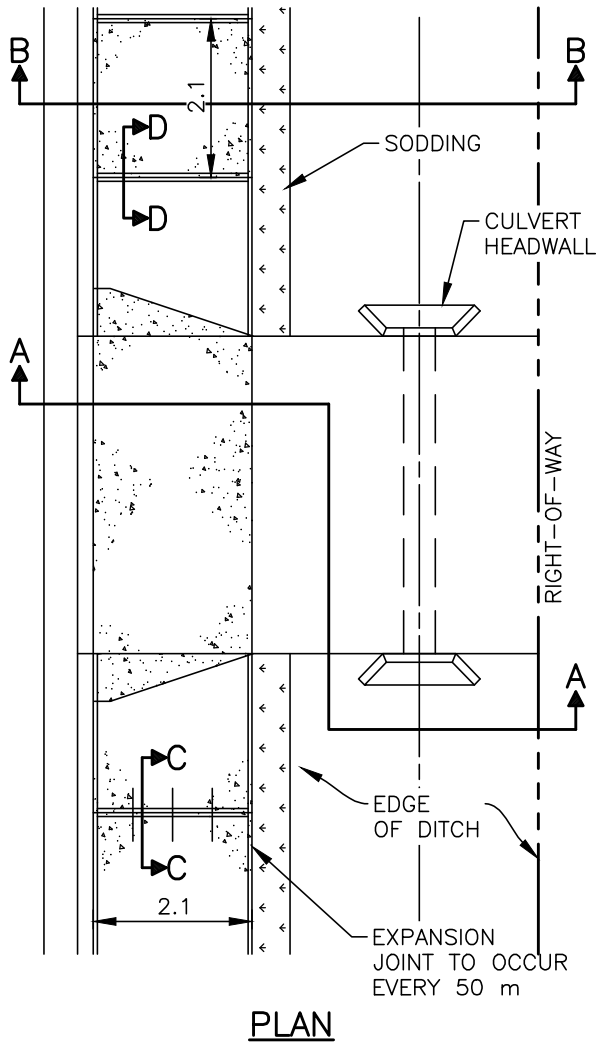

PLAN

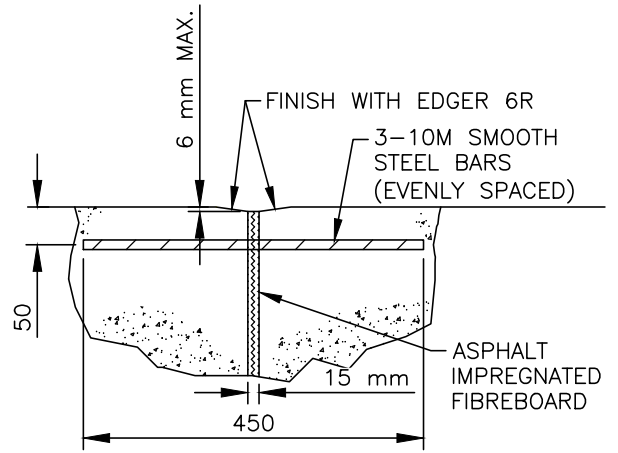

**SECTION C-C
(EXPANSION JOINT)**

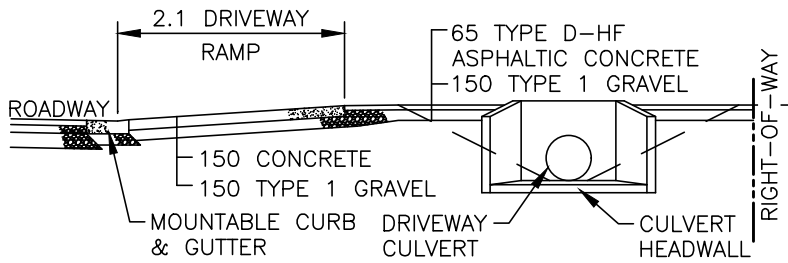

**SECTION A-A
(DRIVEWAY CROSS-SECTION)**

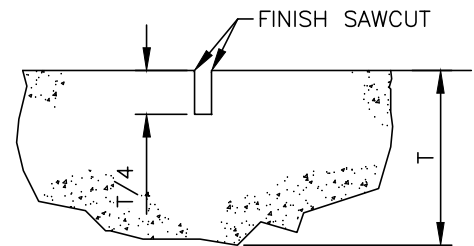

**SECTION D-D
(CONTROL JOINT)**

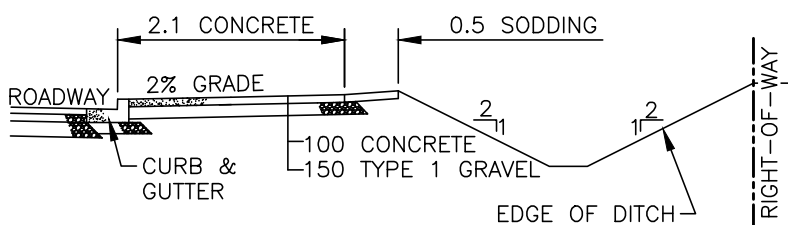

**SECTION B-B
(DRIVEWAY CROSS-SECTION)**

HALIFAX

STANDARD DETAIL

**RURAL TYPE II
SIDEWALK**

DATE:	2021	REFERENCE	APPROVED
SCALE:	NTS	FIG No.:	HRM 46

NOTES:

1. CONCRETE SIDEWALK AT COMMERCIAL DRIVEWAY TO BE 150 THICK WITH 150 x 150 WELDED WIRE MESH.
2. CRUSHED ROCK BASE TO EXTEND 150 BEYOND EDGE OF SIDEWALK STRUCTURE.
3. CONTROL JOINTS ARE TO BE SAW CUT.
4. SIDEWALKS ABUTTING COMMERCIAL AREAS ARE TO BE FULL WIDTH (3 m) AND 150 mm THICKNESS.
5. EXPANSION JOINT BARS ARE TO BE GREASED ON ONE SIDE OF THE JOINT. DURING CONSECUTIVE POURS, THE END OF EACH POUR IS TO OCCUR AT AN EXPANSION JOINT. WHERE THIS IS NOT FEASIBLE, AND ADDITIONAL EXPANSION JOINT IS TO BE INSTALLED.
6. INSTALL A 9 m LONG CONCRETE LANDING PAD AT ALL BUS STOP LOCATIONS. INCREASE THIS TO 14.5 m FOR ARTICULATED BUS ROUTES.

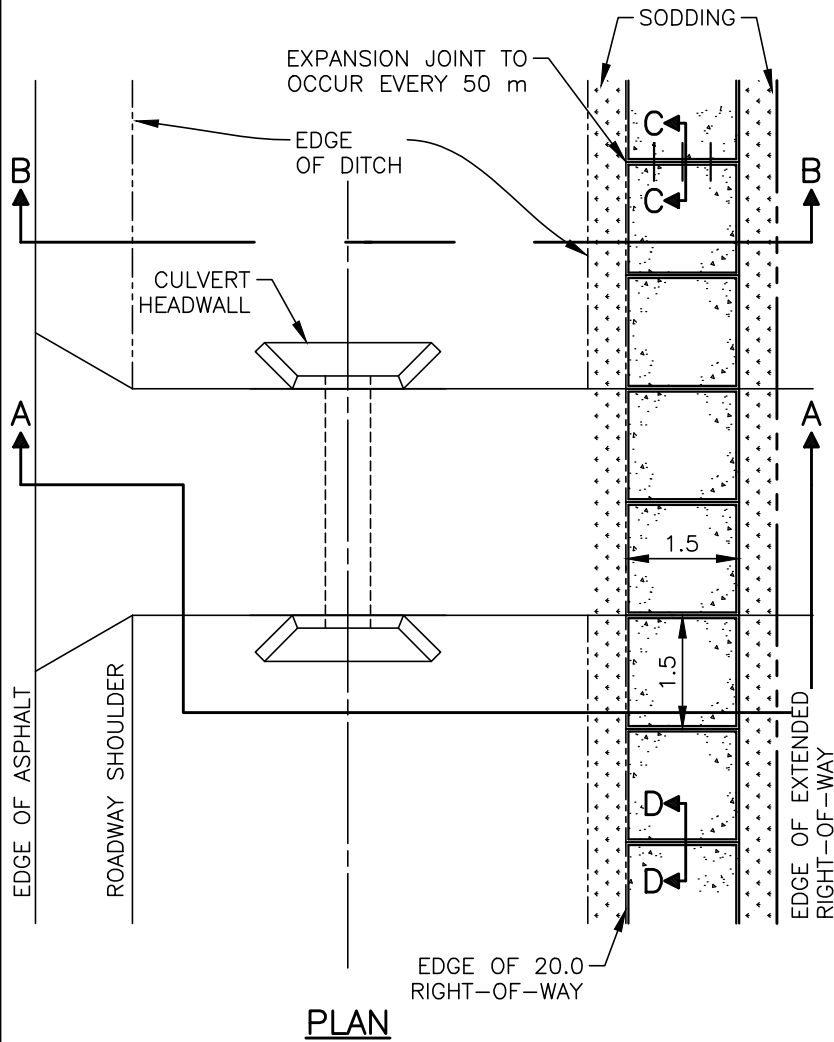

PLAN

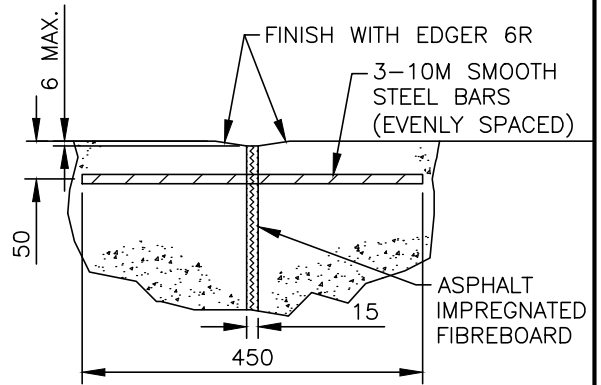

**SECTION C-C
(EXPANSION JOINT)**

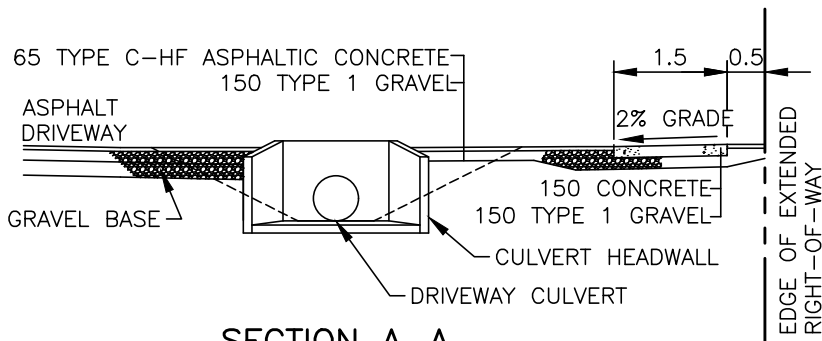

**SECTION A-A
(DRIVEWAY CROSS-SECTION)**

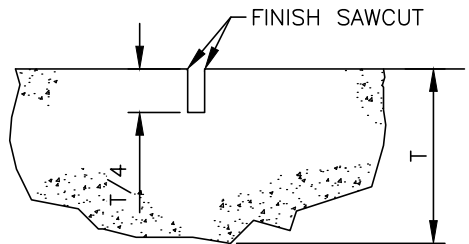

**SECTION D-D
(CONTROL JOINT)**

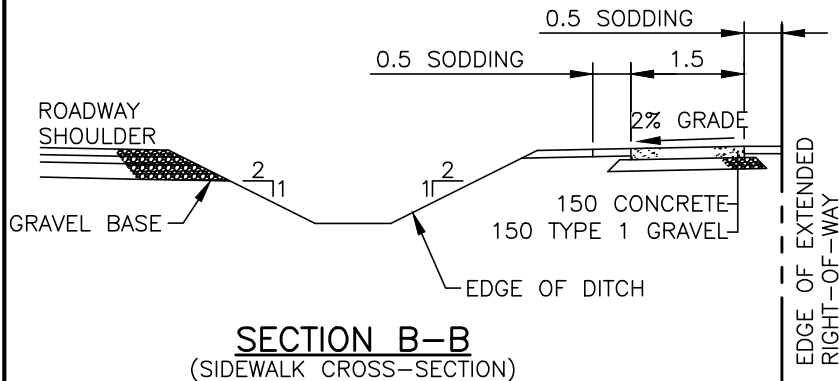

**SECTION B-B
(SIDEWALK CROSS-SECTION)**

HALIFAX

STANDARD DETAIL

RURAL TYPE III SIDEWALK

DATE:	2021	REFERENCE:	APPROVED:
SCALE:	NTS	FIG No.:	HRM 47

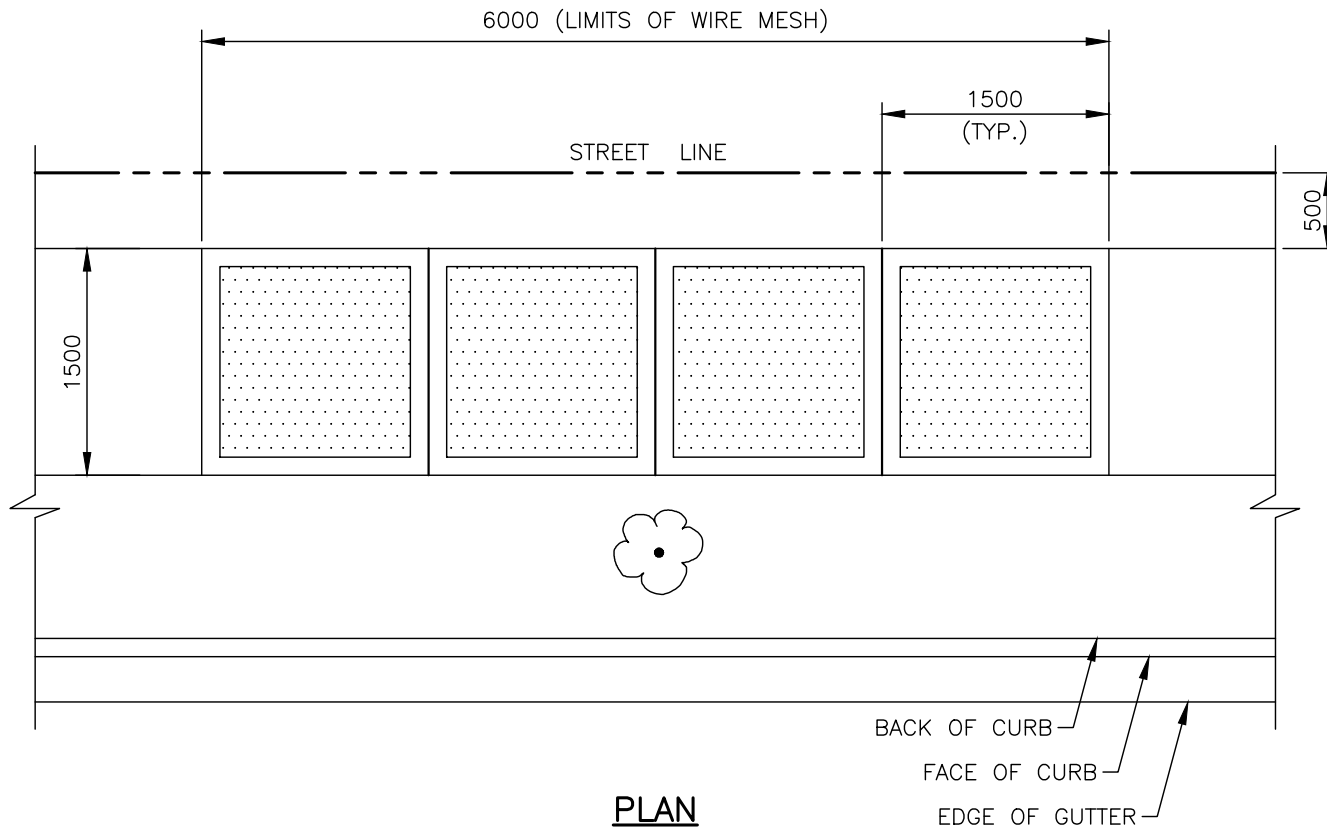

PLAN

NOTES:

1. 150 x 150 – M.W. 18.7 x M.W. 18.7 (WELDED WIRE FABRIC 4.88 mm DIA.)
PLACED AT 1/2 THE SLAB DEPTH, CHAIRS REQUIRED TO ACHIEVE 1/2 DEPTH
PLACEMENT OF WWF.
2. NO TREE ROOTS TO BE REMOVED WITHOUT HRM APPROVAL.

HALIFAX

STANDARD DETAIL

**CONCRETE SIDEWALK
REINFORCING**

DATE:	2021	REFERENCE	APPROVED
SCALE:	1:50		FIG No.: HRM 48

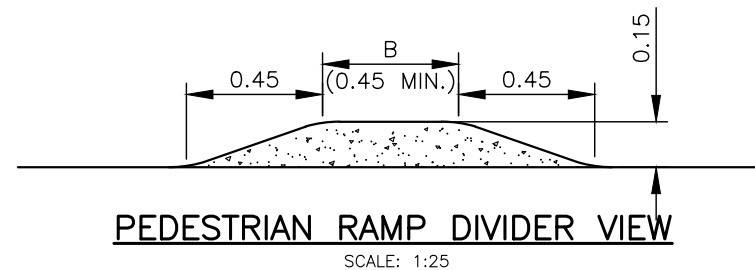
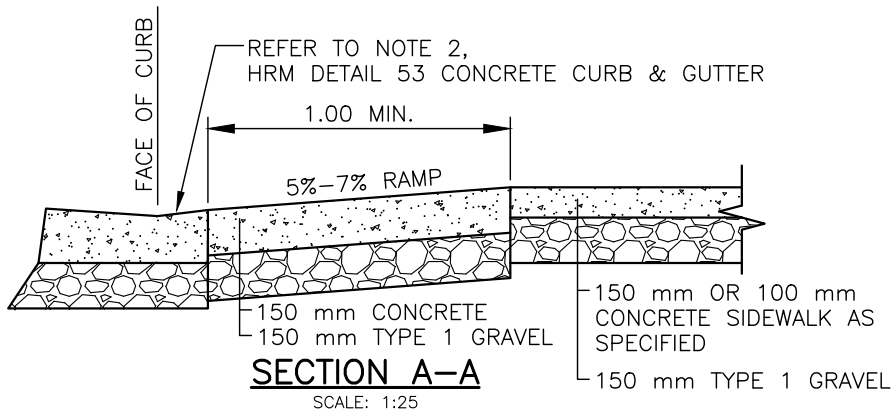
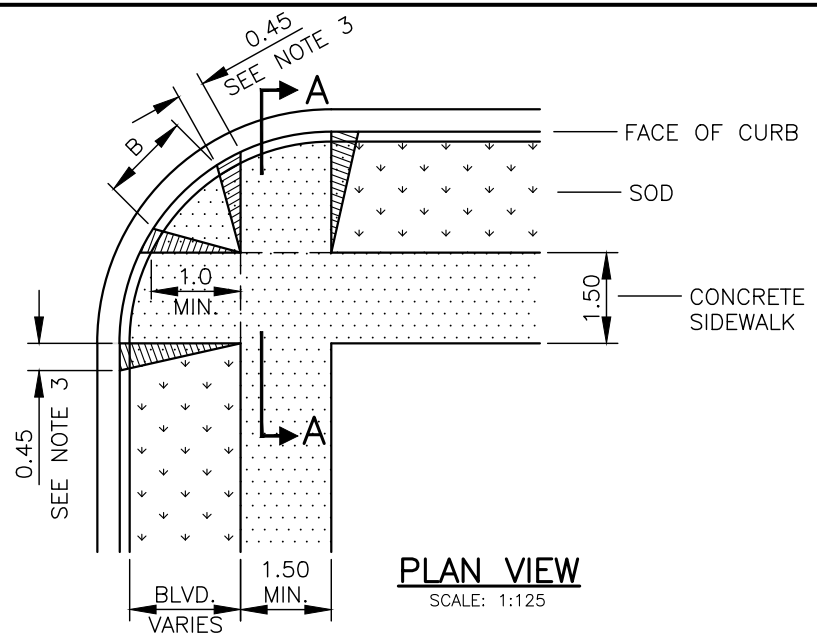
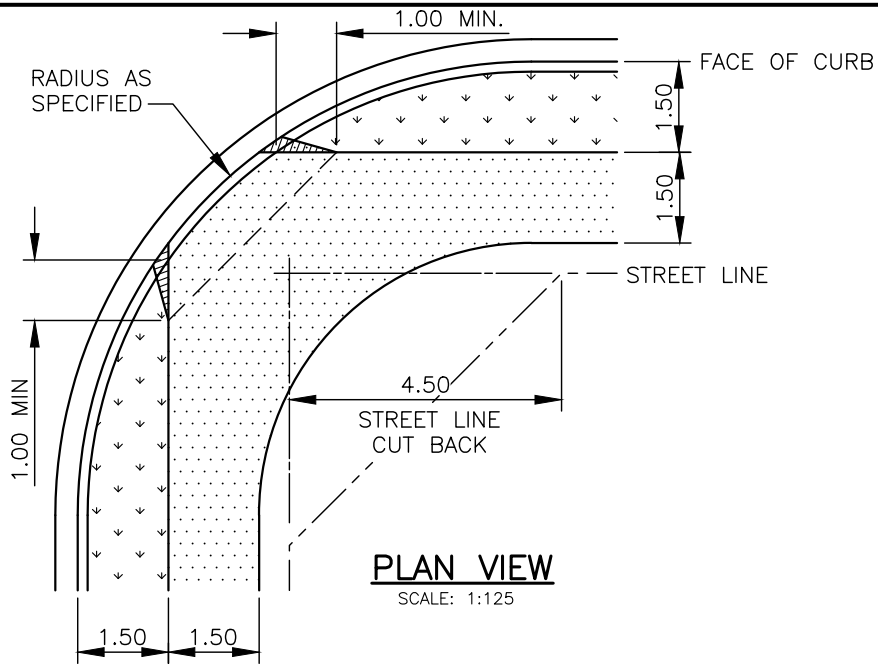

NOTES:

1. PEDESTRIAN RAMPS SHALL BE ALIGNED WITH THE SIDEWALK INSIDE EDGE.
2. INSTALL RAMP DIVIDER ONLY WHEN (B) WILL BE GREATER THAN 0.45 m.
3. WHERE THE BOULEVARD IS LESS THAN 1.5 m, A 1.3 m CURB TRANSITION TAPER IS REQUIRED.
4. IF THE DISTANCE FROM BACK OF CURB TO BACK OF SIDEWALK IS LESS THAN 2 m, SLOPE AT 5% FROM BACK OF CURB TO BACK OF SIDEWALK.
5. TACTILE WALKING SURFACE INDICATOR PLATES REQUIRED AT ALL NEW RAMPS AS PER HRM DETAIL 131.
6. FOR STREETS OF LESS THAN 8%, TRANSITION CURB AND SIDEWALK TO MAXIMUM GRADE OF 8%, OR TIE IN AT 3 m. FOR SIDEWALK, 1.3 m FOR CURB.
7. PEDESTRIAN RAMP OPENING TO BE 1.7 m MINIMUM, MEASURED FROM 0.1 m BEYOND THE EXTENSION OF THE SIDEWALK TO THE CURB.
8. DIMENSIONS ARE IN METRES UNLESS OTHERWISE NOTED.

HALIFAX

STANDARD DETAIL

PEDESTRIAN RAMP
ALIGNMENT

DATE: 2021	REFERENCE	APPROVED
SCALE: AS NOTED		FIG No.: HRM 49

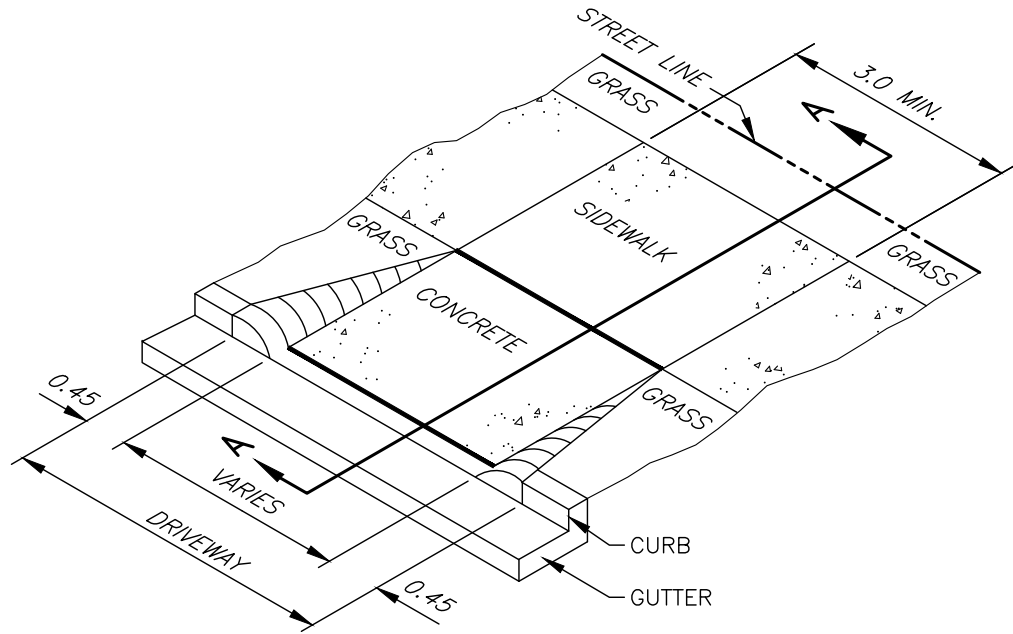

VIEW PLAN

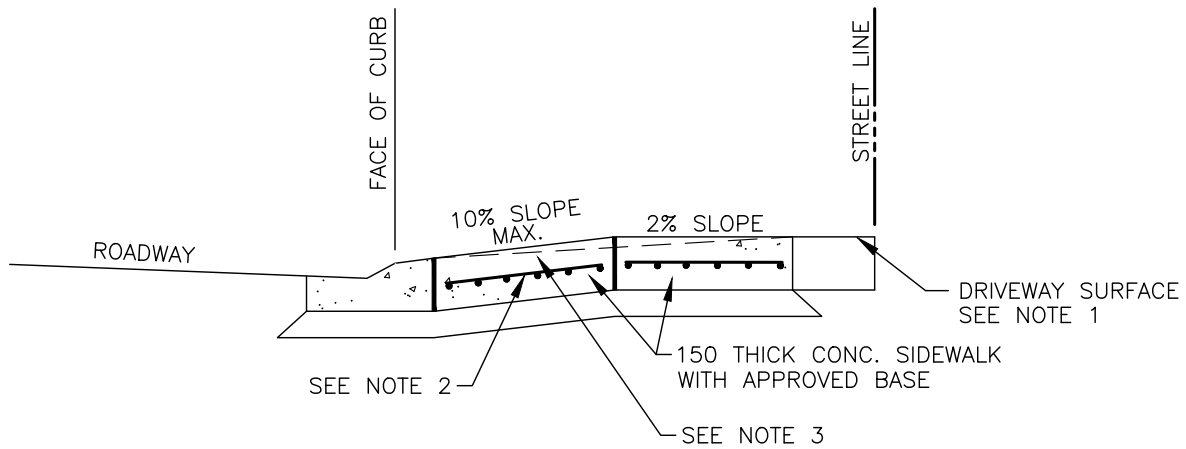

SECTION A-A

NOTES:

1. GRAVEL DRIVEWAYS ARE TO BE PAVED 1 m BEHIND THE SIDEWALK OR TO THE STREETLINE WHICHEVER IS LESS. IF NO SIDEWALK EXISTS, 1 m ASPHALT PAVING IS REQUIRED.
2. FOR COMMERCIAL AND INDUSTRIAL DRIVEWAYS PLACE 150 x 150 – M.W. 18.7 x M.W. 18.7 PLACED 50 mm FROM BOTTOM OF CONCRETE RAMP AND SIDEWALK.
3. WHEN BOULEVARD IS LESS THAN 1.5 m OR WHEN THE SIDEWALK ABUTS THE CURB & GUTTER, REFER TO HRM 133.
4. MINIMUM DISTANCE BETWEEN CONTROL JOINTS IS 1200. PROVIDE CONTROL JOINTS WITHIN 150 OF CHANGE IN CROSS SECTION OF CURB.
5. DIMENSIONS ARE IN METRES.

HALIFAX		
STANDARD DETAIL		
DRIVEWAY RAMP		
DATE:	REFERENCE	APPROVED
2021		
SCALE:		FIG No.:
NTS		HRM 50

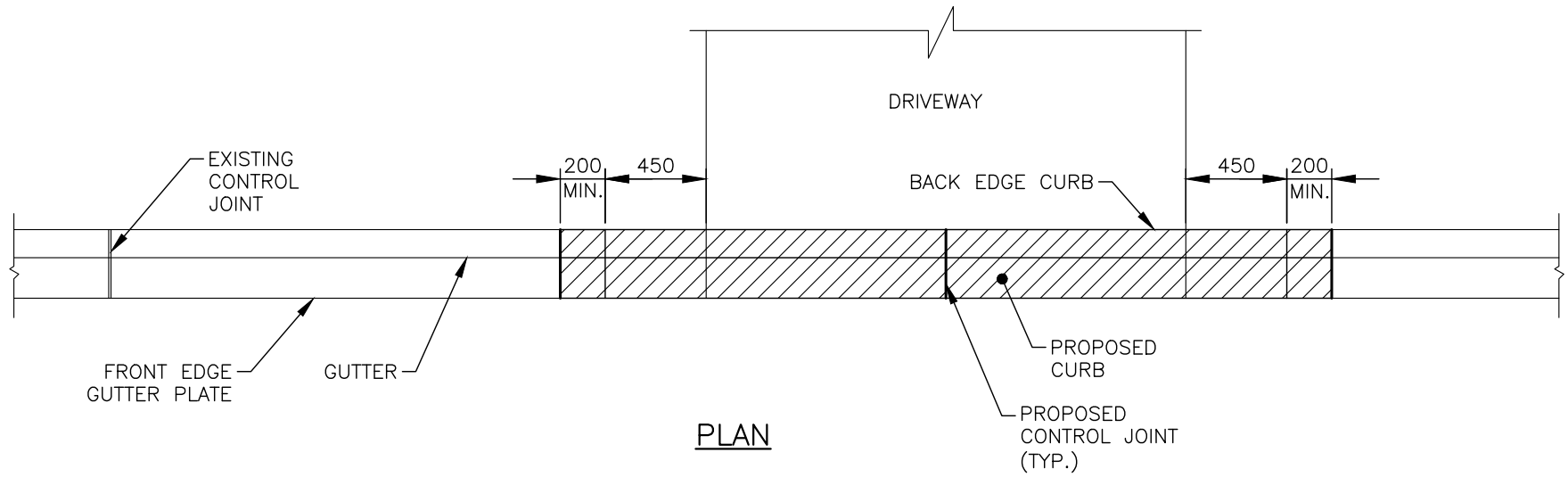

PLAN

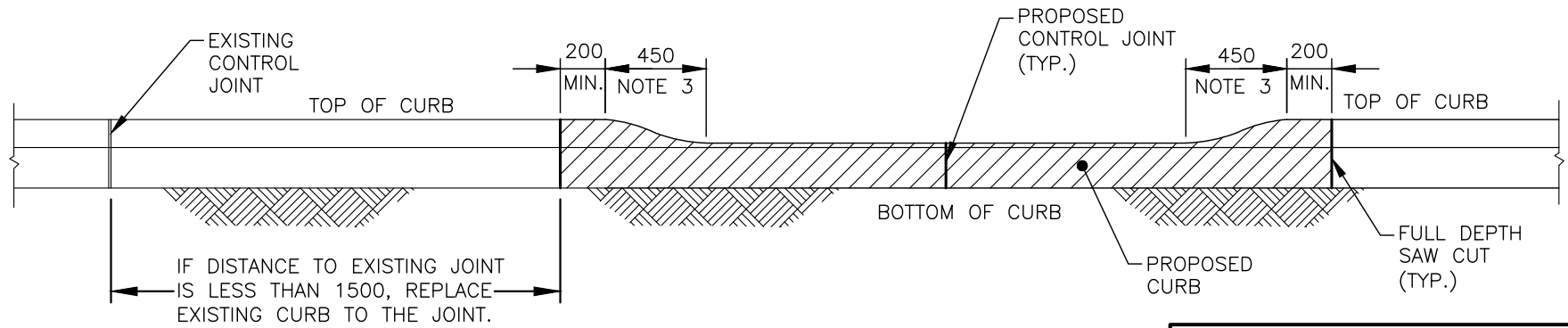

ELEVATION

NOTES:

1. MINIMUM DISTANCE BETWEEN CONTROL JOINTS IS 1200 mm.
2. PROVIDE CONTROL JOINTS WITHIN 150 mm OF CHANGE IN CROSS SECTION OF CURB.
3. IF SIDEWALK ABUTS THE CURB, THE TAPER SHALL BE 1300 mm.
4. DIMENSIONS ARE IN MILLIMETRES.

HALIFAX

STANDARD DETAIL

**DRIVEWAY ACCESS IN
EXISTING FULL-DEPTH CURB**

DATE: 2021	REFERENCE	APPROVED
SCALE: 1:30		FIG No.: HRM 51

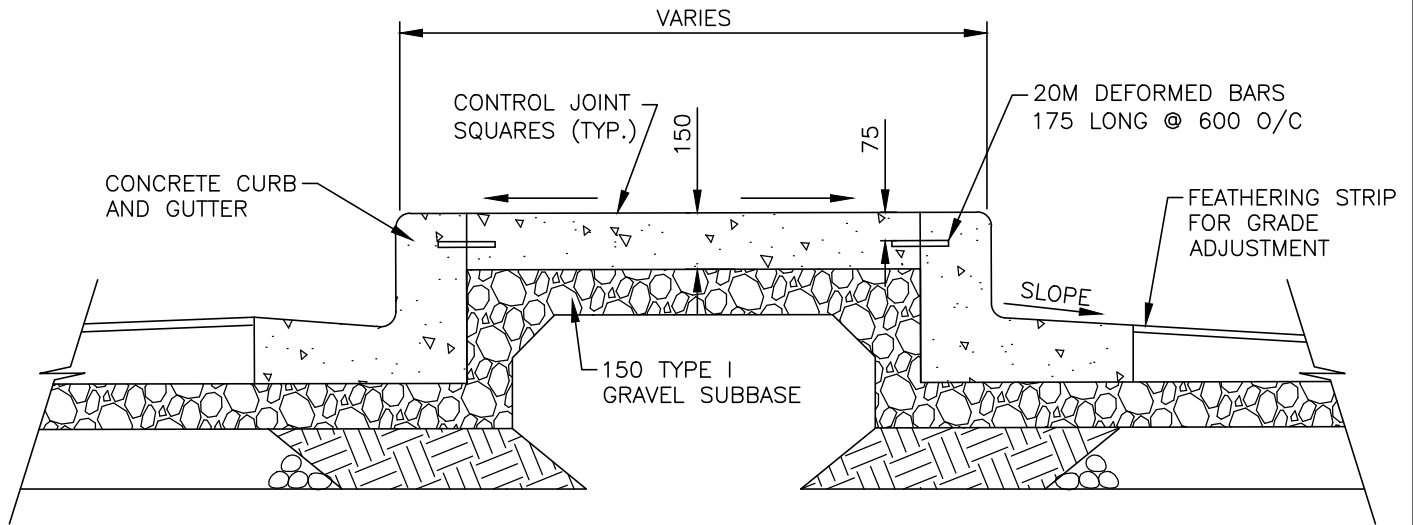

TYPICAL CONCRETE ISLAND CROSS SECTION

NOTES:

1. MAXIMUM SPACING FOR CONTROL JOINTS IS TO BE 2.5 m.
2. SLOPE SLAB TO FACILITATE DRAINAGE.
3. SLOPE GUTTER TO MATCH STREET CROSS SECTION.
4. ENDS AND CORNERS OF TRAFFIC ISLANDS TO HAVE HIGH BACK CONCRETE CURB AND GUTTER.
5. GEOMETRIC DESIGN OF CONCRETE ISLANDS TO BE AS PER PART A AND/OR THE TAC GEOMETRIC DESIGN GUIDE.

HALIFAX

STANDARD DETAIL

**CONCRETE
TRAFFIC ISLAND**

DATE:	2021	REFERENCE	APPROVED
SCALE:	1:20		FIG No.: HRM 52

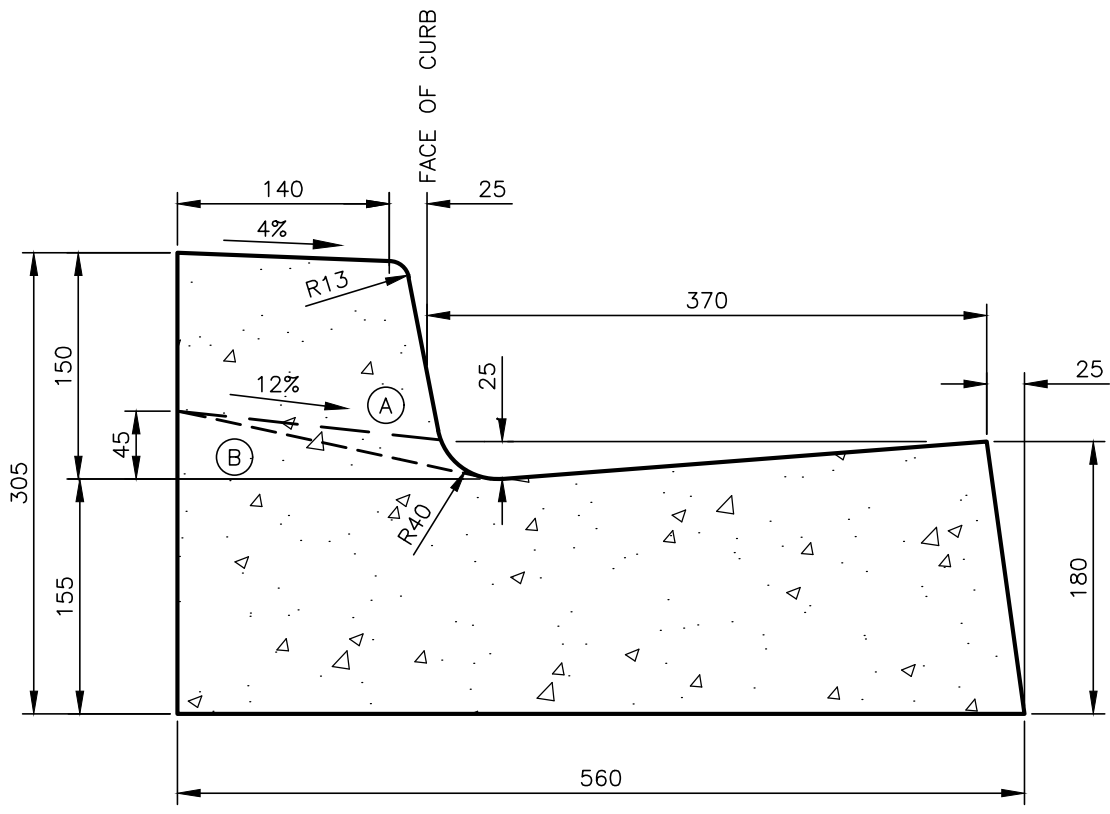

CURB & GUTTER SECTION

NOTES:

1. DASHED LINE "A" INDICATES CURB AT DRIVEWAYS.
2. DASHED LINE "B" INDICATES CURB AT PEDESTRIAN RAMPS.
3. TRANSITION TAPERS SHALL BE PROVIDED AT DRIVEWAYS AND PEDESTRIAN RAMPS AS PER THE "PEDESTRIAN RAMP ALIGNMENT" DETAIL AND "DRIVEWAY RAMP" DETAIL.

HALIFAX		
STANDARD DETAIL		
CONCRETE CURB & GUTTER		
DATE:	REFERENCE	APPROVED
2021		
SCALE:		FIG No.:
1:5		HRM 53

2 mm x 50 mm REINSTATEMENT TAPE (m)
(REQUIRED IF STREET IS
NOT BEING RESURFACED)

CURB & GUTTER PAYMENT INCLUDES
150 mm TYPE 1 GRANULAR BASE

SOD

TYPE C-HF ASPHALTIC CONCRETE

600 mm

TYPICAL PAVEMENT WIDTH FOR
ASPHALT AND GRAVELS FOR
CURB RENEWAL SITUATIONS

150 mm

TYPE B-HF ASPHALTIC CONCRETE

TYPE 1 GRAVEL (m²)

TYPE 2 GRAVEL (m²)

TYPE 2 GRAVEL (m²)

1
2

1
2

NOTES:

1. CURB AND GUTTER PAYMENT INCLUDES A GRANULAR BASE OF 150 mm OF TYPE 1 GRAVEL, OR AS INDICATED ON DRAWINGS.
2. ASPHALT AND GRAVEL THICKNESS AS INDICATED ON DRAWING.

HALIFAX

STANDARD DETAIL

CURB RENEWAL/PAYMENT

DATE:	2021	REFERENCE	APPROVED
SCALE:	1:10		FIG No.: HRM 54

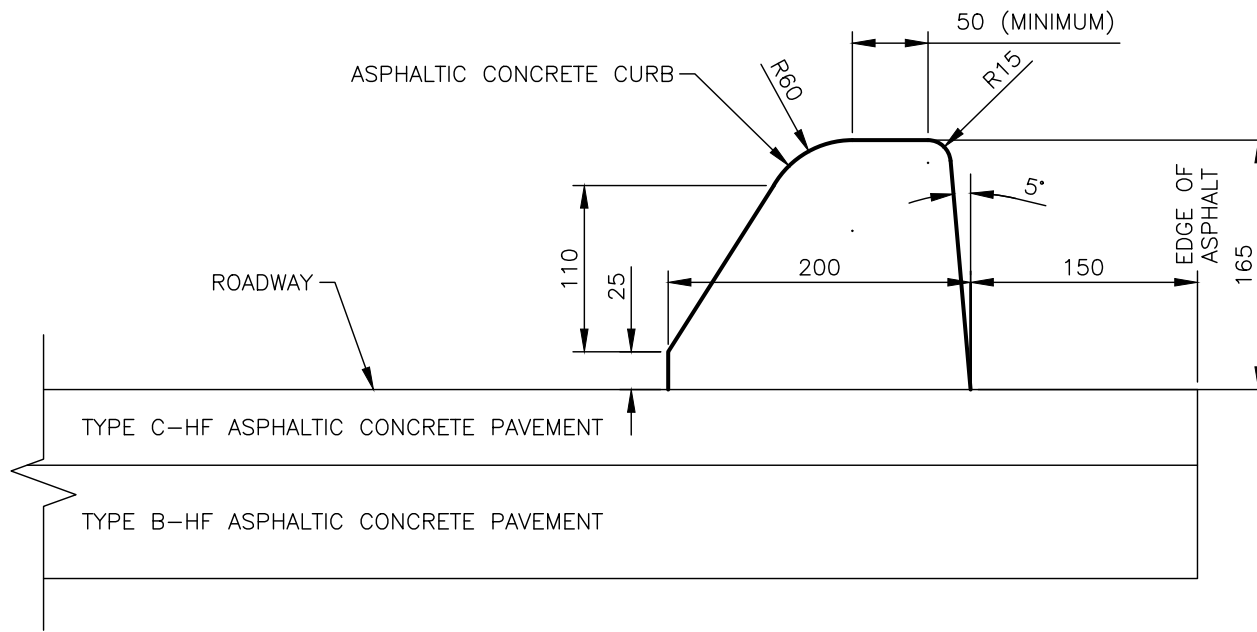

HALIFAX

STANDARD DETAIL

ASPHALT CURB

DATE:	2021	REFERENCE	APPROVED
SCALE:	1:5		FIG No.: HRM 55

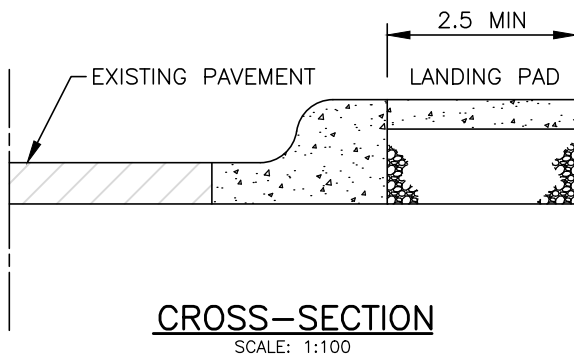
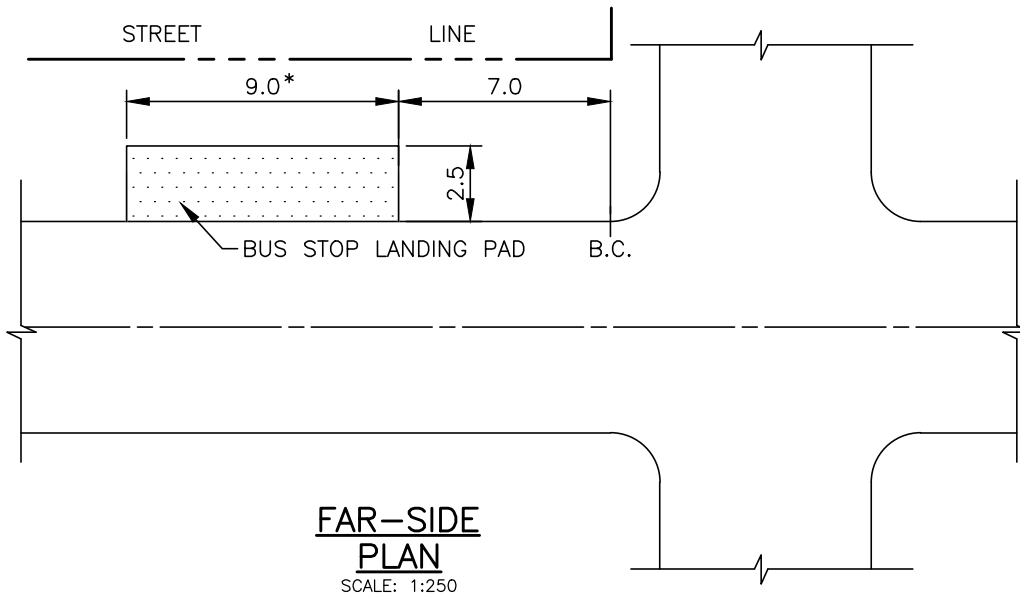
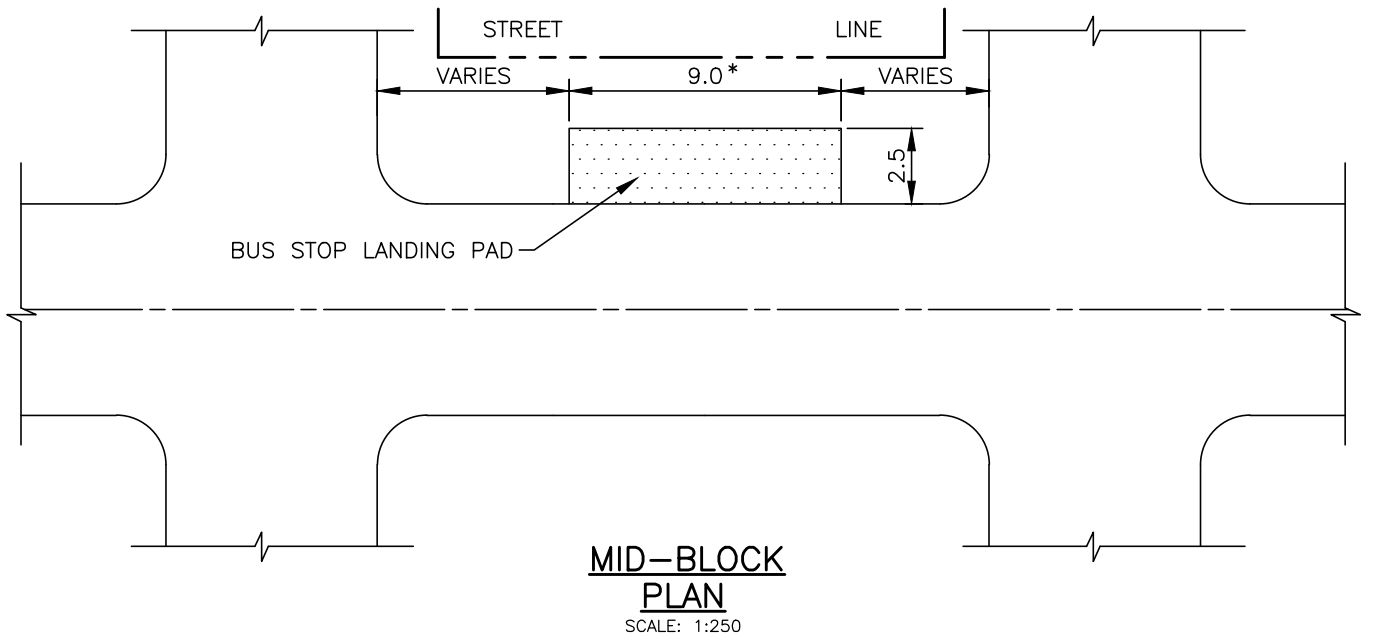

NOTES:

1. * FOR ARTICULATED BUS ROUTES INCREASE TO 14.5 m.
2. THE 2.5 m LANDING PAD MAY INCLUDE PORTION OF SIDEWALK.

HALIFAX

STANDARD DETAIL

**CONCRETE BUS STOP
LANDING PAD**

DATE:	2021	REFERENCE	APPROVED
SCALE:	AS NOTED		FIG No.:
			HRM 56

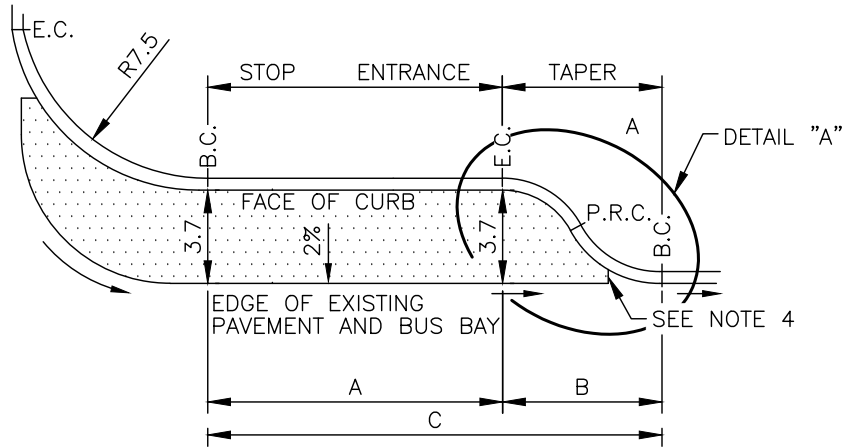

PLAN

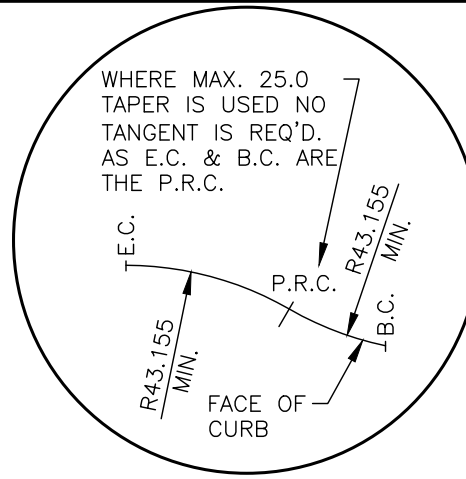

DETAIL "A"

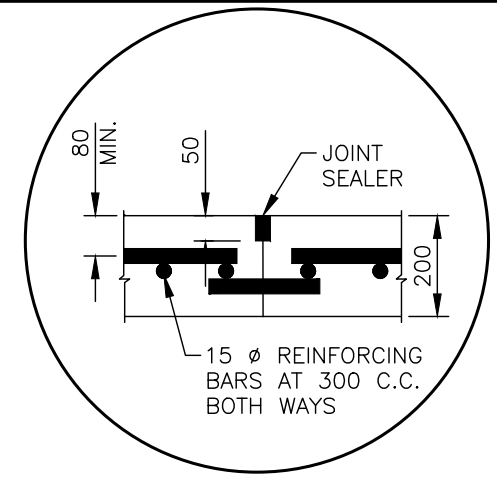

DETAIL "B"
(CONTRACTION JOINT)

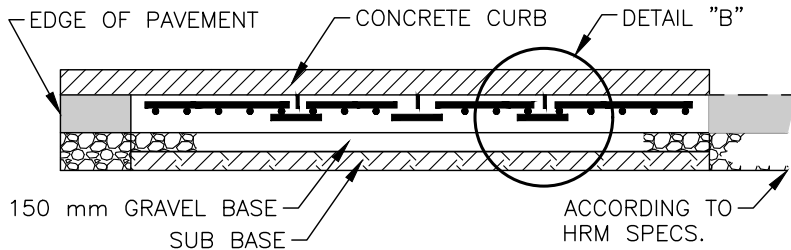

LONGITUDINAL SECTION

	SINGLE BUS BAY (MINIMUM DIMENSION)	DOUBLE BUS BAY (MINIMUM DIMENSION)
A	16	34
B	25	25
C	41	59

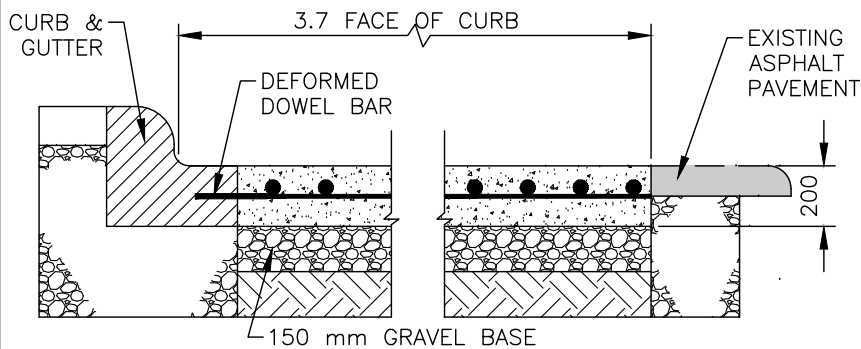

TRANSVERSE SECTION

NOTES:

- 15M BARS AT 300 mm C.C. BOTH WAYS.
- CONTROL JOINTS TO BE AT A DEPTH OF 1/4 OF PAD THICKNESS & SEALED ACCORDING TO HRM SPECS.
- CONTROL JOINT EVERY 4.0 m MAXIMUM.
- MINIMUM WIDTH OF CONCRETE BASE IS 0.6 m.

HALIFAX

STANDARD DETAIL

CONCRETE BUS BAY
PAD – END BLOCK

DATE:	2021	REFERENCE	APPROVED
SCALE:	NTS		FIG No.: HRM 57

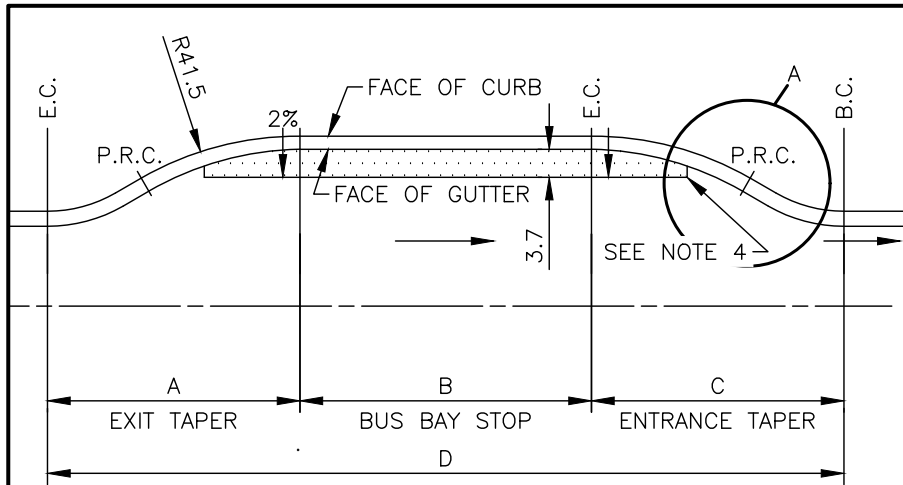

PLAN

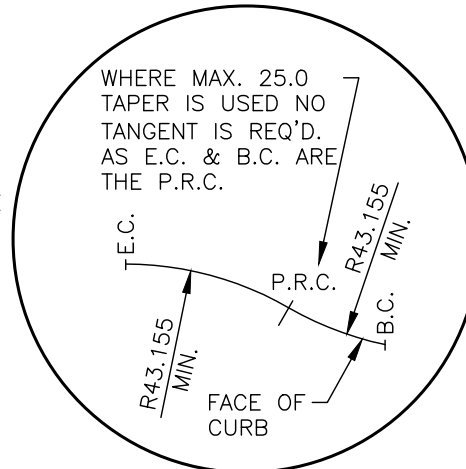

DETAIL "A"

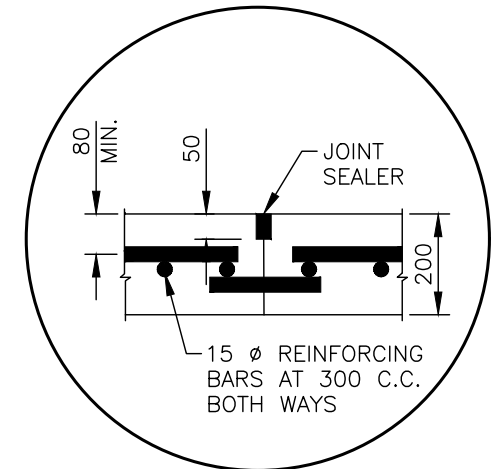

DETAIL "B"
(CONTRACTION JOINT)

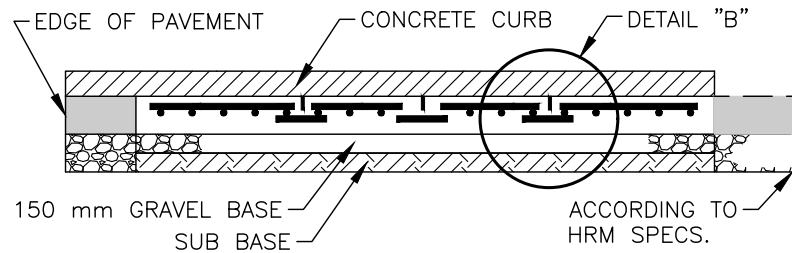

LONGITUDINAL SECTION

	SINGLE BUS BAY MINIMUM DIMENSION	DOUBLE BUS BAY MINIMUM DIMENSION
A	25	25
B	16	32
C	25	25
D	66	82

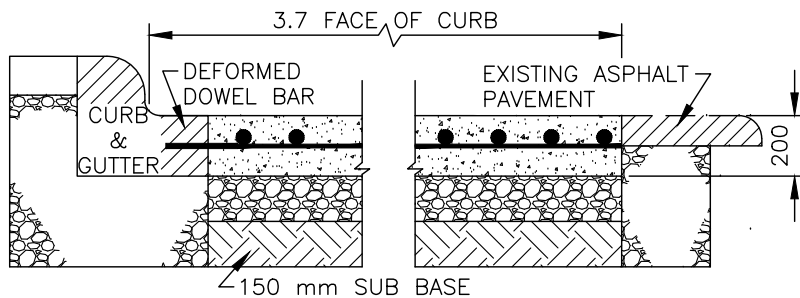

TRANSVERSE SECTION

NOTES:

- 15M BARS AT 300 mm C.C. BOTH WAYS.
- CONTROL JOINTS TO BE AT A DEPTH OF 1/4 OF PAD THICKNESS & SEALED ACCORDING TO HRM SPECS.
- CONTROL JOINT EVERY 4.0 m MAXIMUM.
- MINIMUM WIDTH OF CONCRETE BASE IS 0.6 m.

HALIFAX

STANDARD DETAIL

CONCRETE BUS BAY
PAD – MID BLOCK

DATE:	2021	REFERENCE	APPROVED
SCALE:	NTS		FIG No.: HRM 58

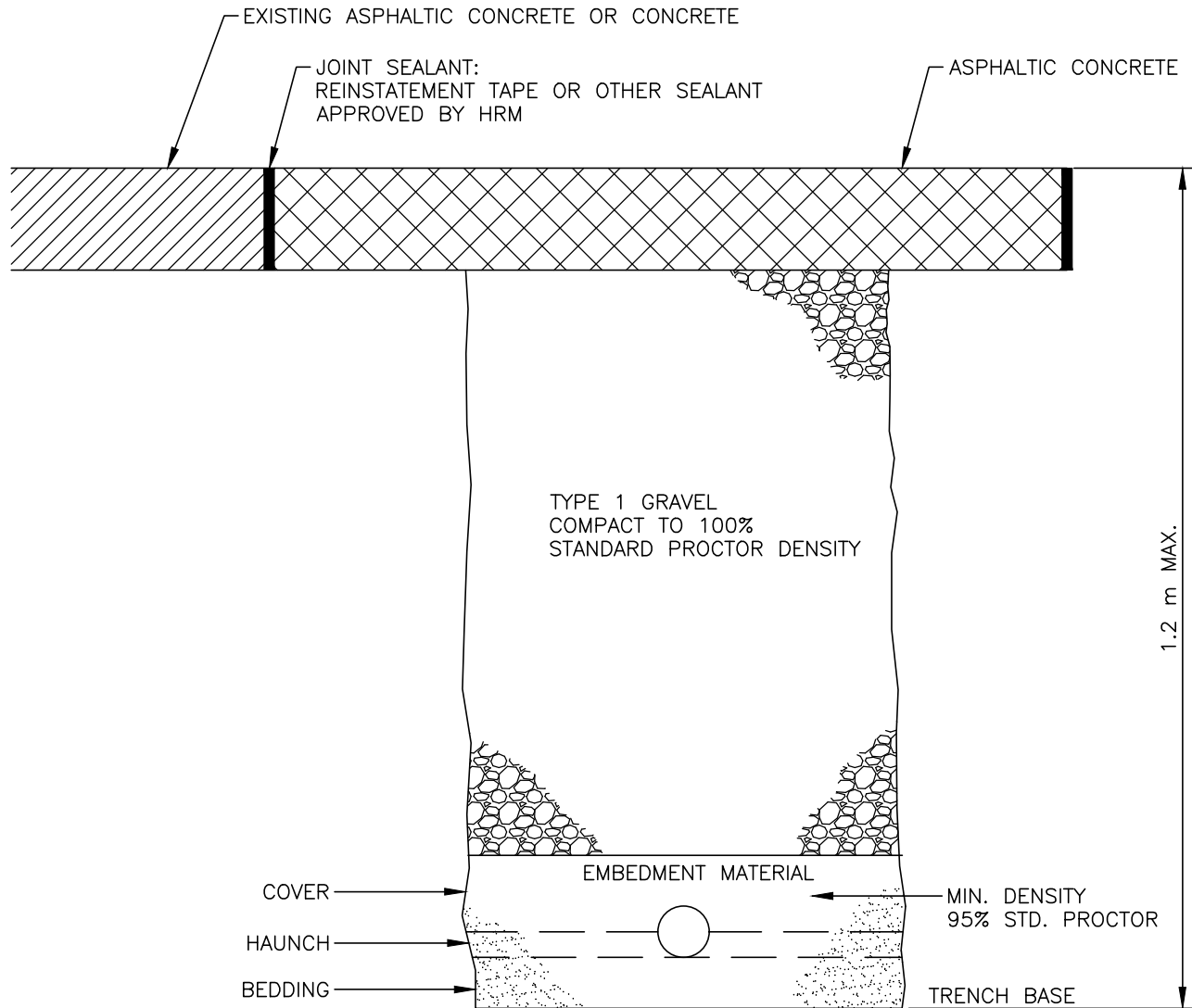

NOTE:

1. REFER TO PART A. MUNICIPAL DESIGN GUIDELINES SECTION 8, TRENCH REINSTATEMENT SPECIFICATIONS FOR SPECIFIC REQUIREMENTS.

HALIFAX

STANDARD DETAIL

SHALLOW TRENCH
REINSTATEMENT

DATE:	2021	REFERENCE	APPROVED
SCALE:	NTS		FIG No.: HRM 59

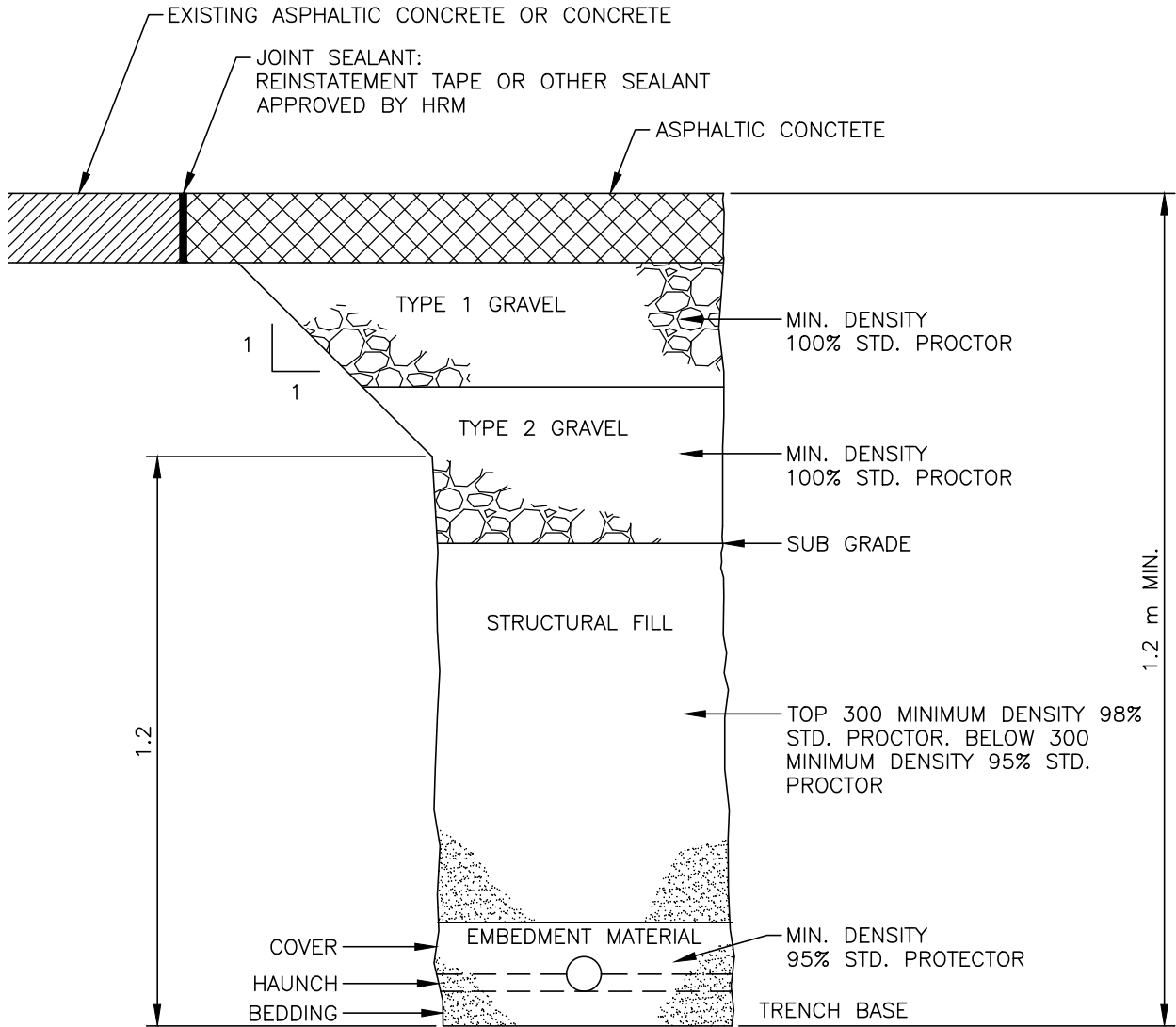

NOTE:

- REFER TO PART A. MUNICIPAL DESIGN GUIDELINES SECTION 8, TRENCH REINSTATEMENT SPECIFICATIONS FOR SPECIFIC REQUIREMENTS.

HALIFAX

STANDARD DETAIL

**DEEP TRENCH
REINSTATEMENT**

DATE:	2021	REFERENCE	APPROVED
SCALE:	NTS		FIG No.: HRM 60

TRENCH BACKFILL AND REINSTATEMENT – TESTING REQUIREMENTS

TEST REQUIRED	COMPACTION REQUIRED	MINIMUM TEST FREQUENCY	
		TRENCH LESS THAN 1.5m WIDE	TRENCH GREATER THAN 1.5m WIDE
COMPACTION OF BEDDING, HAUNCH AND COVER MATERIALS (ASTM D698) *SEE NOTE 3	95% MINIMUM AT 3% ± OF OPTIMUM MOISTURE. (SEE NOTES)	1 PER 25 m AT THE CENTRELINE OF THE TRENCH (AND EACH BENCH OR SECTION OF TRENCH LESS THAN 25 m IN LENGTH) FOR EACH 600 VERTICAL DEPTH OF BACKFILL MATERIAL A MINIMUM OF 3 TESTS PER TRENCH SHALL BE PERFORMED.	3 PER 25 m (AND EACH BENCH OR SECTION OF TRENCH LESS THAN 25 m IN LENGTH) FOR EACH 600 VERTICAL DEPTH OF BACKFILL MATERIAL 1 TEST SHALL BE TAKEN AT THE CENTRELINE OF THE TRENCH (SET BACK AT LEAST 300 mm FROM THE EDGE OF THE TRENCH). A MINIMUM OF 3 TESTS PER TRENCH SHALL BE PERFORMED.
COMPACTION OF STRUCTURAL FILL TO SUBGRADE ELEVATION (ASTM D698) *SEE NOTE 3	TOP 300 98% COMPACTION MINIMUM AT 3% ± OF OPTIMUM MOISTURE. (SEE NOTES)		
	BELOW 300 95% COMPACTION MINIMUM AT 3% ± OF OPTIMUM MOISTURE. (SEE NOTES)		
COMPACTION OF TYPE 1 & TYPE 2 BASE & SUB-BASE MATERIALS (ASTM D698)	100% COMPACTION MINIMUM AT 3% ± OF OPTIMUM MOISTURE (SEE NOTES)	FOR EACH MATERIAL, 1 PER 25 m AT THE CENTRELINE OF THE TRENCH (AND EACH BRANCH OR SECTION OF THE TRENCH LESS THAN 25 m IN LENGTH) FOR EACH 300 VERTICAL DEPTH OF BACKFILL MATERIAL. A MINIMUM OF 3 TESTS PER TRENCH SHALL BE PERFORMED.	FOR EACH MATERIAL, 3 PER 25 m (AND EACH BRANCH OR SECTION OF TRENCH LESS THAN 25 m IN LENGTH) FOR EACH 300 VERTICAL IN DEPTH OF BACKFILL MATERIAL. 1 TESTS SHALL BE TAKEN AT THE CENTRELINE OF THE TRENCH AND 1 AT EACH EDGE OF THE TRENCH (SET BACK AT LEAST 300 mm FROM THE EDGE OF THE TRENCH). A MINIMUM OF 3 TESTS PER TRENCH SHALL BE PERFORMED.
COMPACTION OF HOT MIX ASPHALT PAVEMENT (ASTM D3549 & 2726)	95% OF MAXIMUM THEORETICAL DENSITY OF COMPARATIVE MARSHALL LABORATORY SAMPLE.	ONE TEST FOR EACH 75 m ² OF PAVEMENT SURFACE. A MINIMUM OF 1 TEST PER TRENCH.	ONE TEST FOR EACH 75 m ² OF PAVEMENT SURFACE. A MINIMUM OF 1 TEST PER TRENCH.

NOTES:

1. THE TRENCH WIDTH FOR DETERMINATION OF THE TEST SHALL BE THE WIDTH OF THE TRENCH AT THE LEVEL OF THE TEST BEING PERFORMED.
2. IF MINIMUM MOISTURE DENSITY REQUIREMENTS ARE NOT MET BY THESE TESTS, THE CONTRACTOR SHALL RECOMPACT THE TRENCH AS NEEDED TO ACHIEVE THE SPECIFIED COMPACTION. SUCH RECOMPACTION SHALL EXTEND ON BOTH SIDES OF THE FAILED TEST SECTION A DISTANCE EQUAL TO 1/2 THE DISTANCE FROM WHERE THE LAST TEST WAS TAKEN OR 50 m, WHICHEVER IS LEAST. AN ALTERNATIVE PROCEDURE WOULD BE TO MORE CLEARLY DEFINE THE LIMITS OF THE FAILED AREA TO ADDITIONAL TESTS.
3. TESTING FOR BEDDING, HAUNCH AND STRUCTURAL FILL ARE NOT ONLY REQUIRED WHEN THE TOTAL LENGTH OF TRENCH EXCEEDS 100 m, OR WHEN REQUESTED BY THE HRM INSPECTOR.

HALIFAX

STANDARD DETAIL

**TRENCH BACKFILL &
REINSTATEMENT-TESTING**

DATE:	2021	REFERENCE	APPROVED
SCALE:	NTS		FIG No.: HRM 61

CONIFEROUS
1.8–2 m HEIGHT

DECIDUOUS
60 mm CALIPER

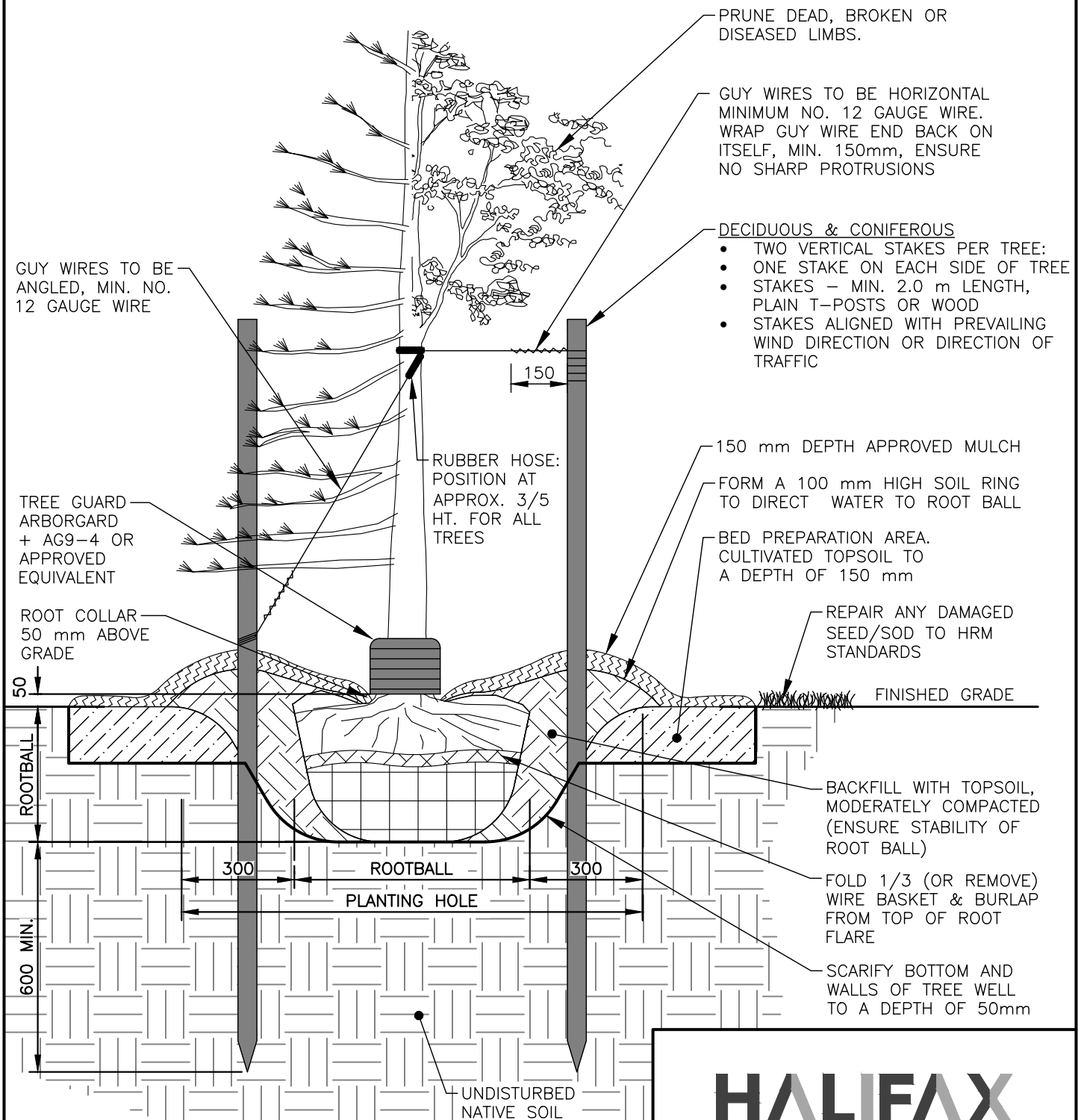

- NOTES:
1. SOAK THE ROOTBALL AND BACKFILL AREA WITH 40 LITRES OF WATER AFTER PLANTING
 2. CUT AND REMOVE ALL WIRE, ROPE, BURLAP AND TWINE FROM THE TOP 1/3 OF THE ROOTBALL
 3. PRUNE AT PLANTING TO CAREFULLY REMOVE DEAD, BROKEN AND DAMAGED BRANCHES
 4. ROOT BALL MIN. SIZE AS PER CNLA STANDARDS FOR NURSERY STOCK.
 5. DIMENSIONS ARE IN MILLIMETRES UNLESS OTHERWISE NOTED.

HALIFAX

STANDARD DETAIL

TREE PLANTING

IN PARKS/OPEN SPACE

DATE:	REFERENCE	APPROVED
2021		
SCALE:		FIG No.:
1:15		HRM 66

PRESOAK ROOT BALL PRIOR TO PLANTING AND REMOVE 2/3 OF BURLAP

FORM SAUCER TO CAPTURE WATER

75 LAYER OF APPROVED MULCH

BACKFILL WITH TOPSOIL & PEAT MOSS PLANTING MIX. WATER AND TAMP TO REMOVE AIR POCKETS. (SEE NOTE #1)

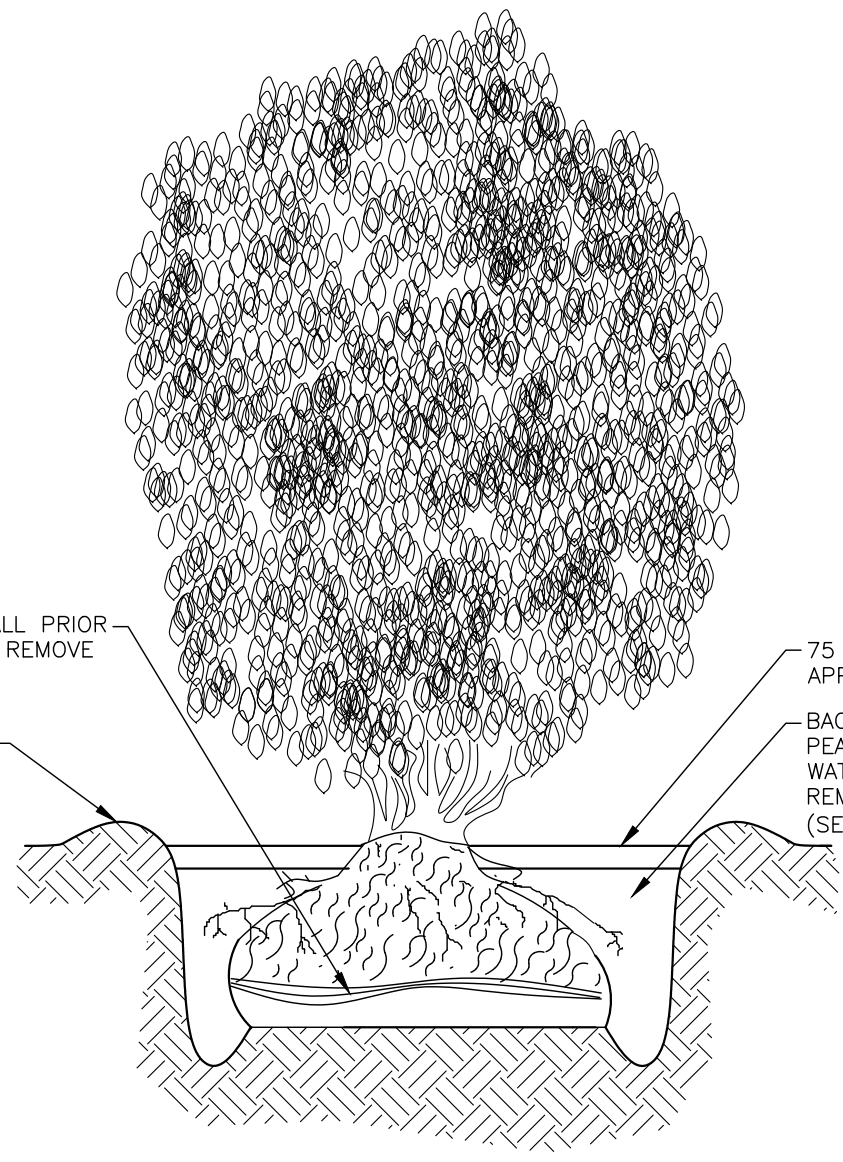

NOTE:

1. PLANTING MIX SHALL BE 3 PARTS FERTILE TOPSOIL TO 1 PART PEAT MOSS.

HALIFAX		
STANDARD DETAIL		
SHRUB PLANTING		
DATE:	2021	REFERENCE
SCALE:	NTS	APPROVED
		FIG No.:
		HRM 67

NOTES FOR SHAFT FOUNDATIONS ONLY:

1. ALL DIMENSIONS IN MILLIMETRES UNLESS OTHERWISE SHOWN.
2. CONCRETE 28 DAY STRENGTH TO BE 35 MPa, CLASS OF EXPOSURE 'C1', AIR CONTENT 5 – 8%.
3. ENGINEER TO CONFIRM SOIL PARAMETERS BEFORE PROCEEDING WITH WORK.
4. DESIGN IS FOR DRY SOIL CONDITIONS (NO GROUND WATER TABLE) WITH A MINIMUM $\gamma_{\text{SOIL}} = 18 \text{ kN/m}^3$, $K_p = 3.5$, $\phi = 34^\circ$.
5. WHERE SOUND BEDROCK IS ENCOUNTERED, FOUNDATION CONSTRUCTION MAY BE MODIFIED TO USE ROCK ANCHORS DOWELED INTO ROCK. REFER TO DRAWING No. 74B.1 AND 74B.2.
6. ANCHORS TO BE MINIMUM GRADE A307, PLATE WASHERS MINIMUM GRADE 300W.
7. CONTRACTOR TO CONFIRM ANCHOR BOLT DIAMETER, LENGTH AND BOLT CIRCLE PRIOR TO PROCEEDING WITH WORK.
8. PROPOSED PVC CONDUIT SIZE AND CONFIGURATION INDICATED ON DRAWINGS. CONDUITS ARE ASSUMED TO BE "BUNCHED" AND IN CENTRE OF PEDESTAL. FOR PEDESTAL WITH NOMINAL DIAMETER OF D-NOM, DIAMETER OF "BUNCHED" CONDUIT AT TOP OF CONCRETE SHALL BE D-B MAXIMUM. IF "BUNCHED" DIAMETER AT TOP OF CONCRETE IS GREATER THAN D-B, USE D-ADJ DIA. PEDESTAL.

D-NOM	D-B	D-ADJ
609	150	762
762	250	914
914	300	1067

9. CONCRETE MUST BE PLACED IN A SINGLE POUR.
10. EMBEDMENT DEPTH OF THE FOUNDATION WAS DERIVED FROM THE ONTARIO MINISTRY OF TRANSPORTATION ENGINEERING STANDARDS BRANCH – GUIDELINES FOR THE DESIGN OF HIGH MAST POLE FOUNDATIONS, 4TH Ed. 2004.
11. TORSIONAL RESISTANCE OF THE FOUNDATION WAS COMPLETED BASED ON BROM'S TORSION LOADING ANALYSIS OF SHORT SINGLE SHAFT FOUNDATIONS.
12. RESIDUAL FRICTIONAL COEFFICIENT (μ) BETWEEN THE CIRCUMFERENCE OF THE FOUNDATION AND SOIL IS TO BE 0.3.
13. WHERE FINISHED GRADE IS LOWER NEAR POLE BASE, HEIGHT OF FOUNDATION TO BE INCREASED AS FOLLOWS:

- 'A' UP TO 0.3m, NO INCREASE.
- 'A' UP TO 0.6m, INCREASE HEIGHT BY 0.2m.
- 'A' UP TO 1.0m, INCREASE HEIGHT BY 0.4m.

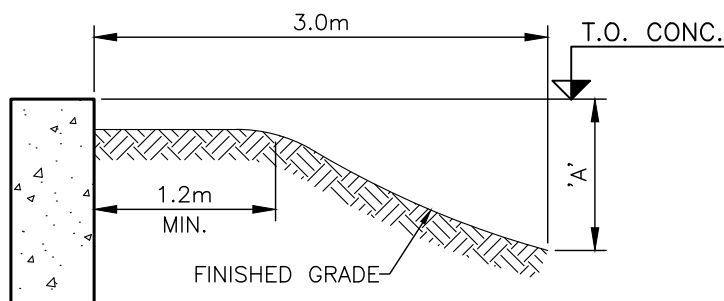

14. ENSURE FULLY COMPACTED SOIL AROUND FOUNDATION.

HALIFAX		
STANDARD DETAIL		
STANDARD NOTES SHAFT FOUNDATIONS		
DATE:	2021	REFERENCE
SCALE:	NTS	APPROVED
		FIG No.: HRM 68N1

NOTES FOR SPREAD FOUNDATIONS ONLY:

1. ALL DIMENSIONS IN MILLIMETRES UNLESS OTHERWISE SHOWN.
2. CONCRETE 28 DAY STRENGTH TO BE 35 MPa, CLASS OF EXPOSURE 'C1', AIR CONTENT 5 – 8%.
3. ENGINEER TO CONFIRM SOIL PARAMETERS BEFORE PROCEEDING WITH WORK.
4. DESIGN IS FOR DRY SOIL CONDITIONS (NO GROUND WATER TABLE) WITH A MINIMUM $\gamma_{\text{SOIL}} = 18 \text{ kN/m}^3$, $K_p = 3.5$, $\phi = 34^\circ$.
5. WHERE SOUND BEDROCK IS ENCOUNTERED, FOUNDATION CONSTRUCTION MAY BE MODIFIED TO USE ROCK ANCHORS DOWELED INTO ROCK. REFER TO DRAWING No. 74B.1 AND 74B.2.
6. ANCHORS TO BE MINIMUM GRADE A307, PLATE WASHERS MINIMUM GRADE 300W.
7. CONTRACTOR TO CONFIRM ANCHOR BOLT DIAMETER, LENGTH AND BOLT CIRCLE PRIOR TO PROCEEDING WITH WORK.
8. PROPOSED PVC CONDUIT SIZE AND CONFIGURATION INDICATED ON DRAWINGS. CONDUITS ARE ASSUMED TO BE "BUNCHED" AND IN CENTRE OF PEDESTAL. FOR PEDESTAL WITH NOMINAL DIAMETER OF D-NOM, DIAMETER OF "BUNCHED" CONDUIT AT TOP OF CONCRETE SHALL BE D-B MAXIMUM. IF "BUNCHED" DIAMETER AT TOP OF CONCRETE IS GREATER THAN D-B, USE D-ADJ DIA. PEDESTAL.

D-NOM	D-B	D-ADJ
609	150	762
762	250	914
914	300	1067

9. FOOTINGS SHALL BEAR ON UNDISTURBED SOIL, STRUCTURAL FILL OR BEDROCK WITH A MINIMUM SERVICEABILITY LIMIT STATES (SLS) BEARING CAPACITY OF 150kPa AND A MINIMUM ULTIMATE LIMIT STATES (ULS) BEARING CAPACITY OF 250kPa.
10. TORSIONAL RESISTANCE ANALYSIS WAS COMPLETED CONSIDERING PASSIVE SOIL PRESSURE AT THE VERTICAL FACE OF THE FOOTINGS AND A FRICTION (μ) BETWEEN THE UNDERSIDE OF THE FOOTING AND SOIL OF 0.4.
11. FINISHED GRADE ELEVATIONS SHALL NOT VARY MORE THAN 150mm OVER A DISTANCE EQUAL TO TWICE THE EMBEDMENT DEPTH.
12. AFTER CONSTRUCTION, CUT OFF TOP OF CMP FORMWORK TO 150mm BELOW FINISHED GRADE.

HALIFAX

STANDARD DETAIL

STANDARD NOTES
SPREAD FOOTINGS

DATE:	2021	REFERENCE	APPROVED
SCALE:	NTS		FIG No.: HRM 68N2

**TRAFFIC SIGNAL POLE BASE DESIGN SELECTION GUIDE FOR TYPE OF POLE BASE
MAXIMUM DESIGN CRITERIA USED FOR DIFFERENT TYPES OF POLE BASES**

CONFIGURATION	POLE TYPE			TRAFFIC SIGNAL EQUIPMENT				PEDESTRIAN HEADS	STREET LIGHTING	SIGNAGE AREA (m ²)	POLE BASE DESIGN TYPE	STANDARD HFV. DWG. NO.
	MATERIAL	BASE DIA. (mm)	TOTAL HEIGHT (m)	MAST ARMS			SIGNAL HEADS (PER POLE)					
				NO.	LENGTH (m)	ORIENTATION						
A	ALUM.	203	5.2	0	N.A.	N.A.	2	2	1@0.4	0	1	68
B	ALUM.	203	5.8	1	4.6	N.A.	2	2	NONE	0.7	2	69
C	ALUM.	203	5.8	2	4.6, TOTAL	180°	2	2	NONE	0.7	2	69
D	ALUM.	203	5.8	2	3.1 EACH	90°	2	2	NONE	0.7	2	69
E	ALUM.	254	8.2	0	N.A.	N.A.	0	0	2@1.85	0	2	69
F	ALUM.	254	6.7	1	6.1	N.A.	2	2	NONE	0.7	3	70
G	ALUM.	254	6.7	2	6.1, TOTAL	180°	2	2	NONE	0.7	3	70
H	ALUM.	254	6.7	2	3.6 EACH	90°	2	2	NONE	0.7	3	70
I	ALUM.	254	6.7	1	7.6	N.A.	2	2	NONE	0.7	4	71
J	ALUM.	254	6.7	2	7.6, TOTAL	180°	2	2	NONE	0.7	4	71
K	ALUM.	254	6.7	2	4.6 EACH	90°	2	2	NONE	0.7	4	71
L	ALUM.	254	11.3	0	N.A.	N.A.	3	2	2@1.85	0	4	71
M	ALUM.	254	9.7	1	7.6	N.A.	2	2	1@1.8	0.7	4A	71A
N	STEEL	254	6.1	1	12.2	N.A.	4	2	NONE	0.7	5	72
O	STEEL	254	6.1	2	12.2, TOTAL	180°	5	2	NONE	0.7	5	72
P	STEEL	254	6.1	2	7.6 EACH	90°	5	2	NONE	0.7	5	72
Q	STEEL	343	10.7	1	12.2	N.A.	4	2	2@3.6m	0.7	5A	72A
R	STEEL	343	10.7	2	12.2, TOTAL	180°	5	2	2@3.6m	0.7	5A	72A
S	STEEL	343	10.7	2	7.6 EACH	90°	5	2	2@3.6m	0.7	5A	72A
T	STEEL	343	6.1	1	18.3	N.A.	4	2	NONE	0.7	6	73
U	STEEL	343	6.1	2	18.3, TOTAL	180°	5	2	NONE	0.7	6	73
V	STEEL	343	6.1	2	10.7 EACH	90°	5	2	NONE	0.7	6	73
W	STEEL	343	10.7	1	18.3	N.A.	4	2	2@3.6m	0.7	6A	73A
X	STEEL	343	10.7	2	18.3, TOTAL	180°	5	2	2@3.6m	0.7	6A	73A
Y	STEEL	343	10.7	2	10.7 EACH	90°	5	2	2@3.6m	0.7	6A	73A
Z	STEEL	343	6.1	1	21.3	N.A.	4	2	NONE	0.7	7	74
AA	STEEL	343	6.1	2	21.3, TOTAL	180°	5	2	NONE	0.7	7	74
AB	STEEL	343	6.1	2	12.2 EACH	90°	5	2	NONE	0.7	7	74
AC	STEEL	343	10.7	1	21.3	N.A.	4	2	2@3.6m	0.7	7A	74A
AD	STEEL	343	10.7	2	21.3, TOTAL	180°	5	2	2@3.6m	0.7	7A	74A
AE	STEEL	343	10.7	2	12.2 EACH	90°	5	2	2@3.6m	0.7	7A	74A
AF	ALUM.	254	13.4	0	N.A.	N.A.	0	0	2@3.6m	0.7	8	74X

NOTES

- REFER TO HALIFAX STANDARD DRAWINGS 68 TO 74X FOR ADDITIONAL NOTES AND DESIGN CRITERIA.
- SEE STANDARD DRAWING NO. HRM 74B FOR REVISED POLE BASE FOUNDATION DESIGN WHICH MAY BE PERMITTED IN ROCK CONDITIONS.
- TRAFFIC SIGNAL POLE DESIGN CRITERIA MAY DIFFER FROM THAT AS SHOWN ON THIS TABLE. SHOULD THIS OCCUR, DESIGN ENGINEER SHALL BE CONSULTED FOR INTERPRETATION OF TABLE AND SELECTION OF POLE BASE TYPE, OR ADDITIONAL DESIGN IF REQUIRED.

HALIFAX

STANDARD DETAIL

**POLE BASE
SELECTION GUIDE**

DATE:	2021	REFERENCE	APPROVED
SCALE:	NTS		FIG No.: HRM 68N3

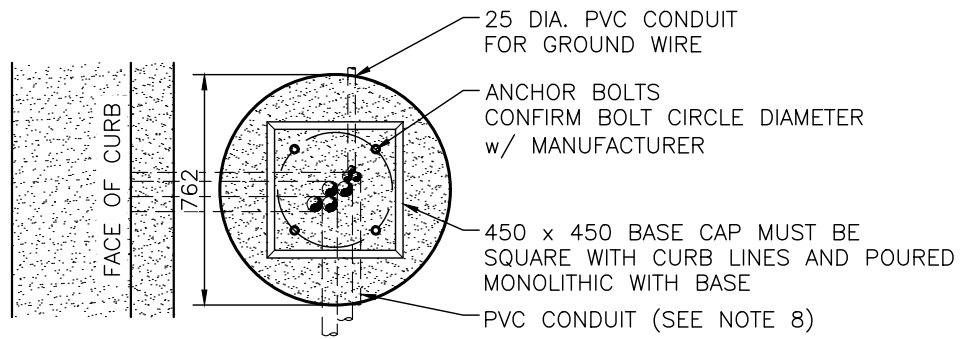

PLAN

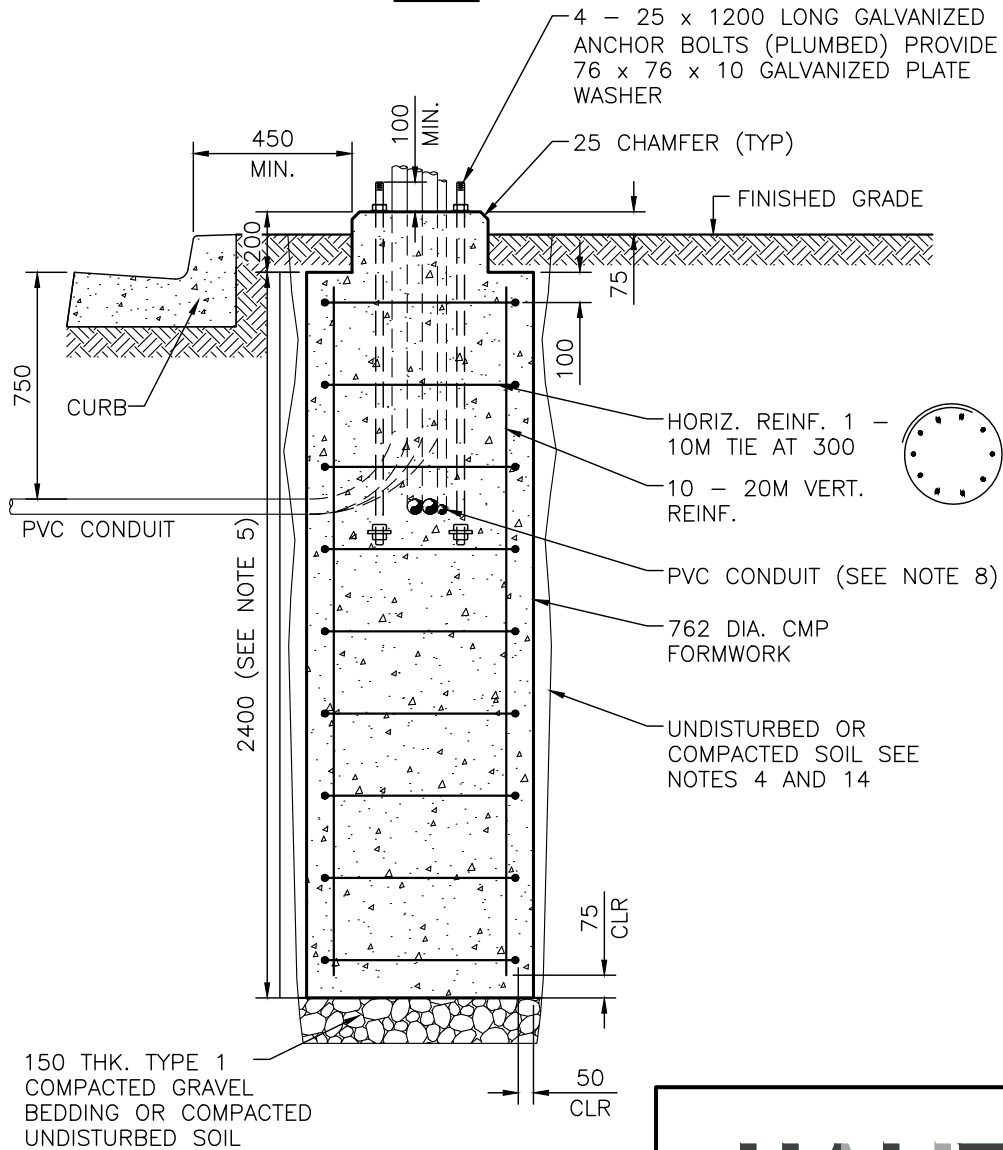

SECTION

NOTES:

1. SEE HRM 68N3, SELECTION GUIDE, FOR PERMITTED POLES AND TRAFFIC SIGNAL EQUIPMENT.
2. FOR NOTES REFER TO HRM 68N1.
3. DIMENSIONS ARE IN MILLIMETRES.

<h1>HALIFAX</h1>		
STANDARD DETAIL		
TRAFFIC SIGNAL BASE FOR CONFIGURATIONS B, C, D AND E		
DATE:	REFERENCE	APPROVED
2021		
SCALE:		FIG No.:
1:25		HRM 69

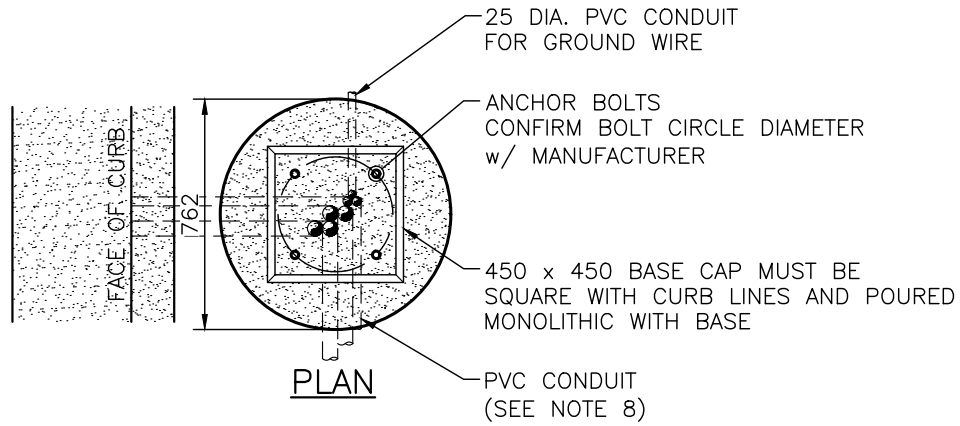

4 - 31 x 1000 LONG GALVANIZED ANCHOR BOLTS (PLUMBED) PROVIDE 76 x 76 x 10 GALVANIZED PLATE WASHER

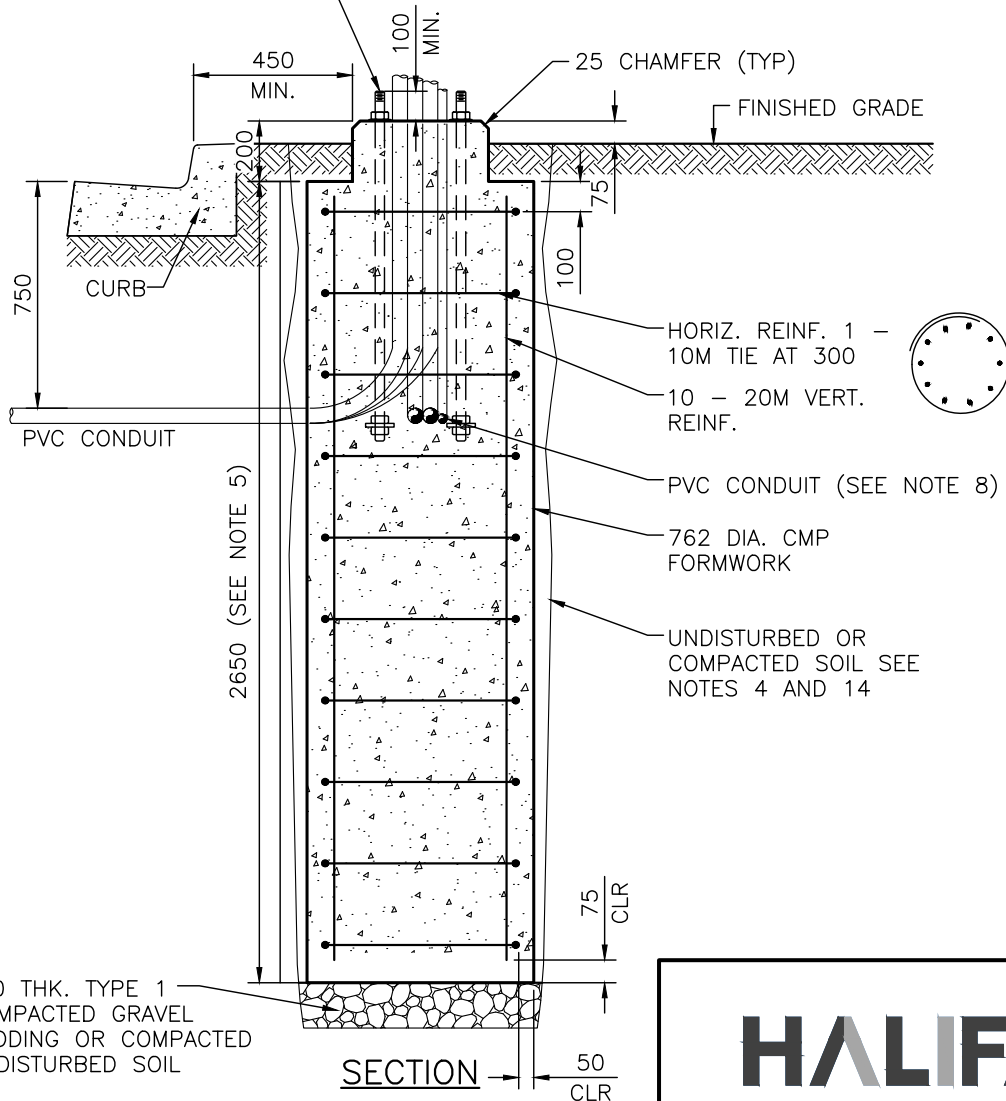

NOTES:

1. SEE HRM 68N3, SELECTION GUIDE, FOR PERMITTED POLES AND TRAFFIC SIGNAL EQUIPMENT.
2. FOR NOTES REFER TO HRM 68N1.
3. DIMENSIONS ARE IN MILLIMETRES.

HALIFAX		
STANDARD DETAIL		
TRAFFIC SIGNAL BASE FOR CONFIGURATIONS F, G AND H		
DATE:	REFERENCE	APPROVED
2021		
SCALE:		FIG No.:
1:25		HRM 70

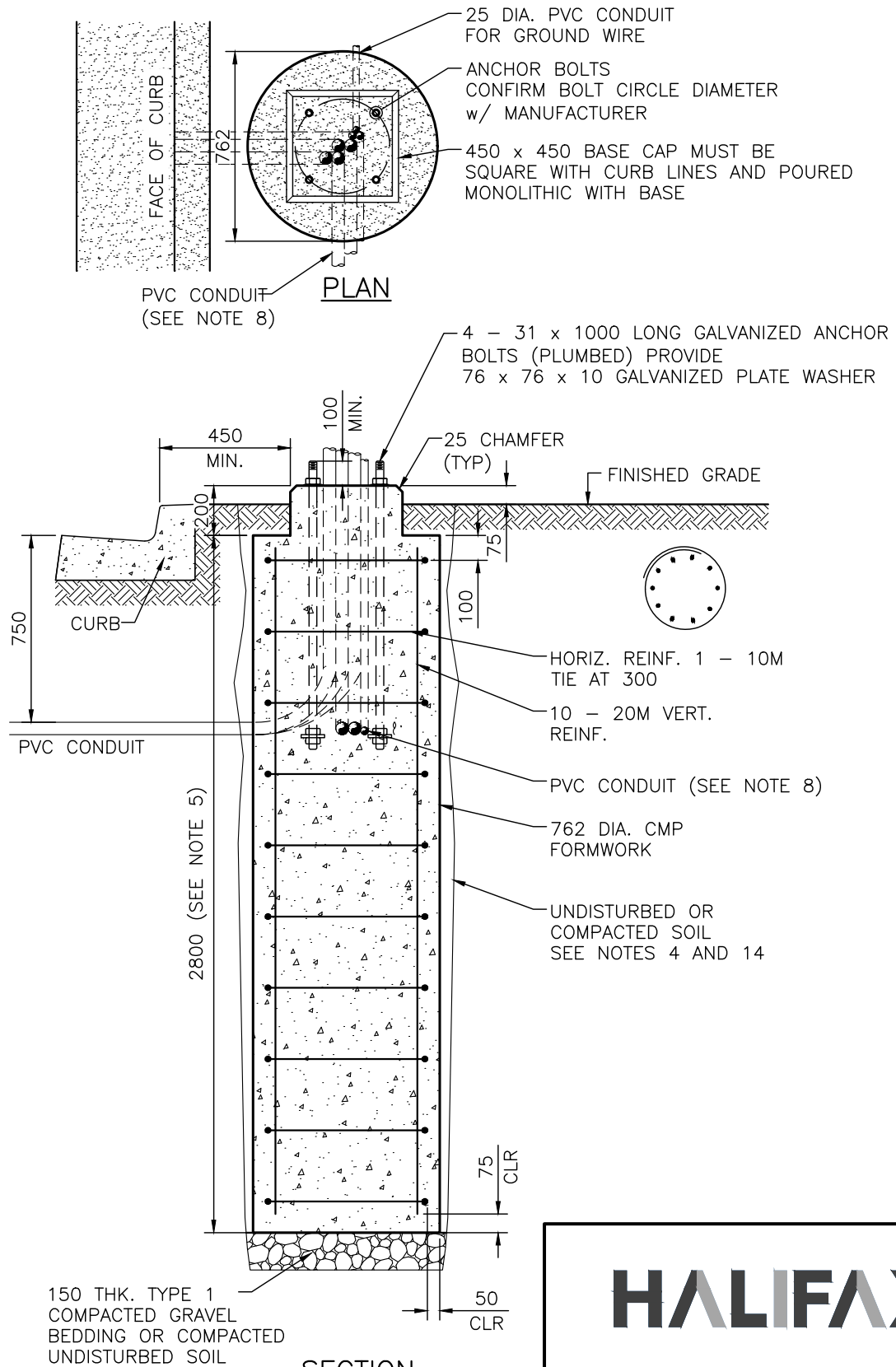

NOTES:

1. SEE HRM 68N3, SELECTION GUIDE, FOR PERMITTED POLES AND TRAFFIC SIGNAL EQUIPMENT.
2. FOR NOTES REFER TO HRM 68N1.
3. DIMENSIONS ARE IN MILLIMETRES.

SECTION

HALIFAX		
STANDARD DETAIL		
TRAFFIC SIGNAL BASE FOR CONFIGURATION I, J, K AND L		
DATE:	REFERENCE	APPROVED
2021		
SCALE:		FIG No.:
1:25		HRM 71

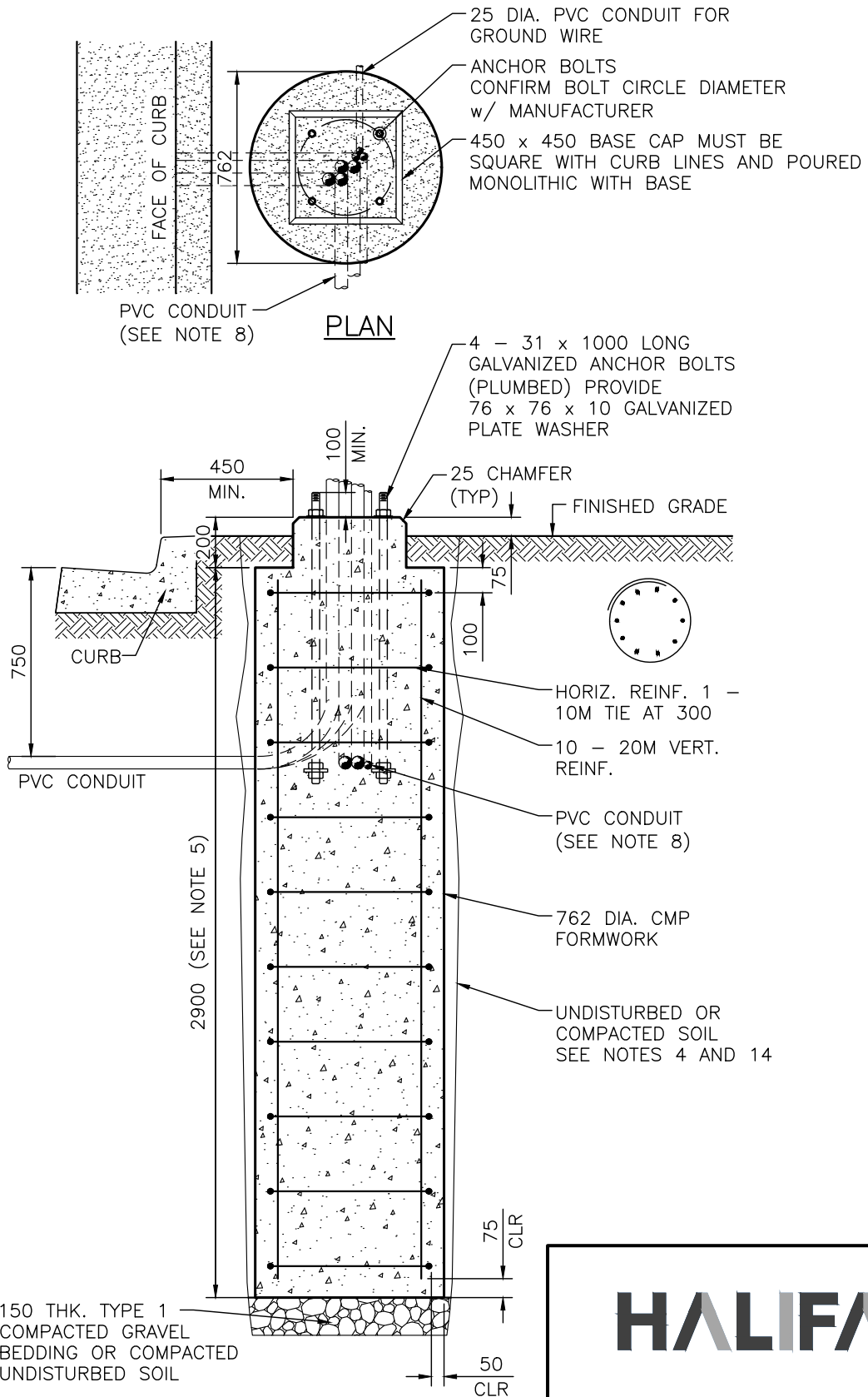

NOTES:

1. SEE HRM 68N3, SELECTION GUIDE, FOR PERMITTED POLES AND TRAFFIC SIGNAL EQUIPMENT.
2. FOR NOTES REFER TO HRM 68N1.
3. DIMENSIONS ARE IN MILLIMETRES.

<h1 style="margin: 0;">HALIFAX</h1>		
STANDARD DETAIL		
TRAFFIC SIGNAL BASE FOR CONFIGURATION M		
DATE: 2021	REFERENCE	APPROVED
SCALE: 1:25		FIG No.: HRM 71A

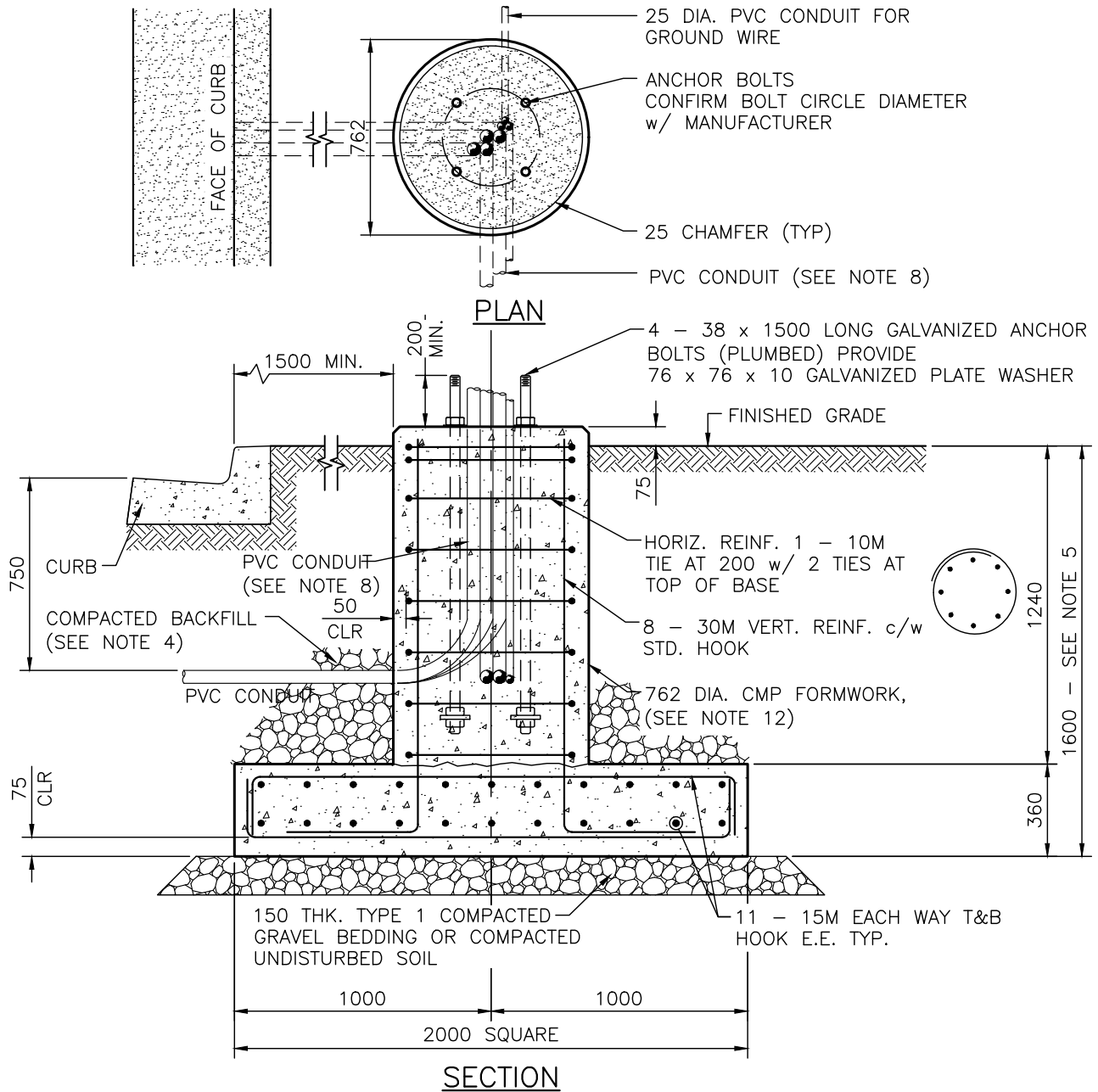

NOTES:

1. SEE HRM 68N3, SELECTION GUIDE, FOR PERMITTED POLES AND TRAFFIC SIGNAL EQUIPMENT.
2. FOR NOTES REFER TO HRM 68N2.
3. DIMENSIONS ARE IN MILLIMETRES.

HALIFAX

STANDARD DETAIL

TRAFFIC SIGNAL BASE FOR CONFIGURATION N, O AND P

DATE:	2021	REFERENCE	APPROVED
SCALE:	1:25		FIG No.: HRM 72

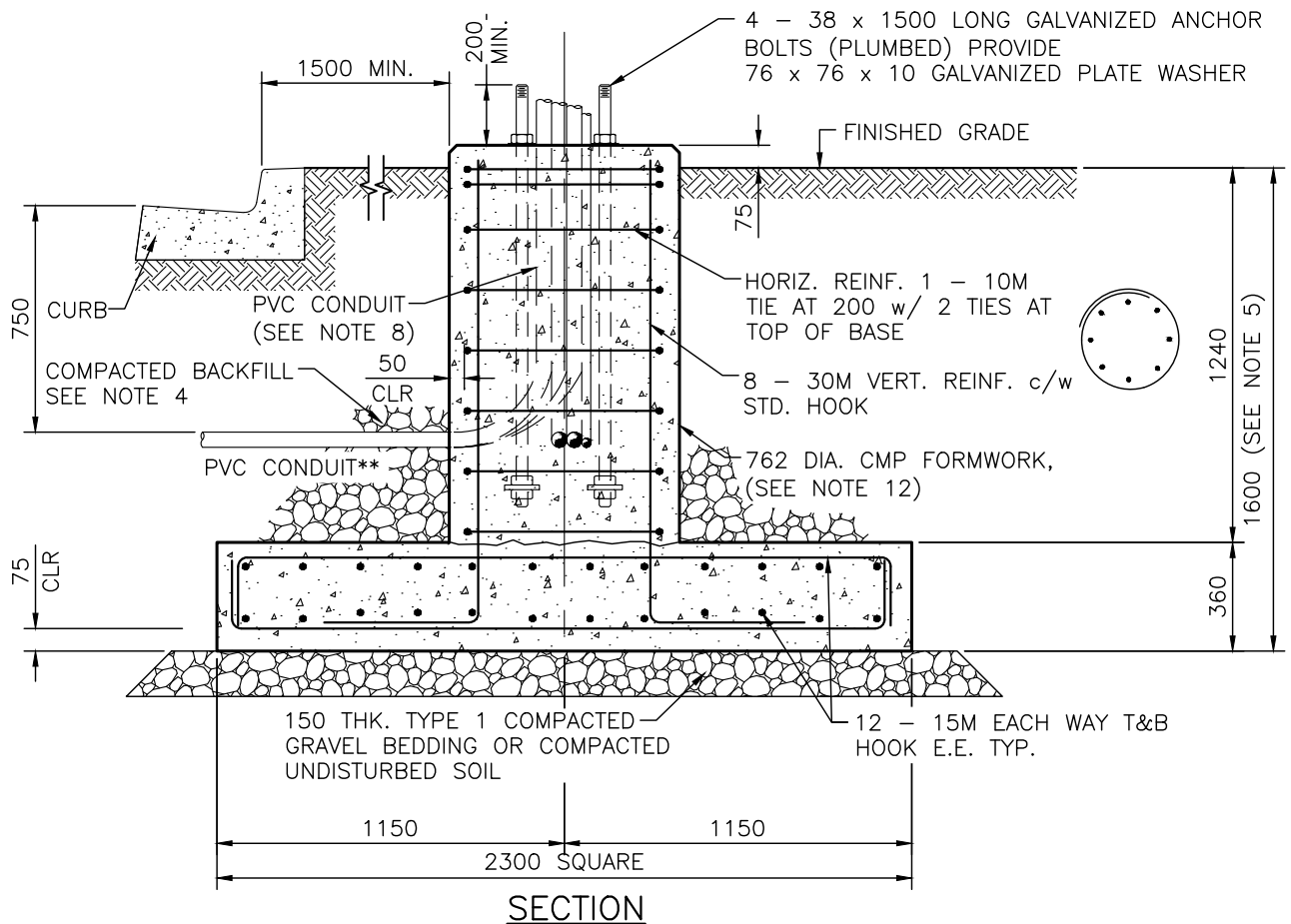
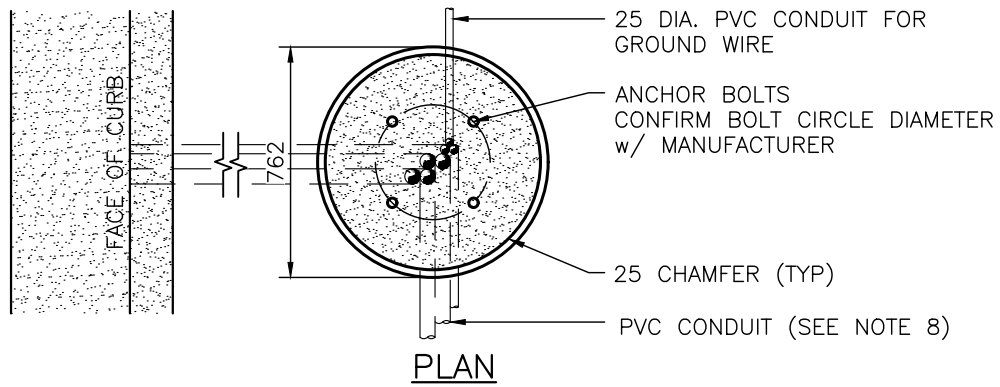

NOTES:

1. SEE HRM 68N3, SELECTION GUIDE, FOR PERMITTED POLES AND TRAFFIC SIGNAL EQUIPMENT.
2. FOR NOTES REFER TO HRM 68N2.
3. DIMENSIONS ARE IN MILLIMETRES.

HALIFAX

STANDARD DETAIL

TRAFFIC SIGNAL BASE FOR CONFIGURATION Q, R AND S

DATE:	2021	REFERENCE	APPROVED
SCALE:	1:25		FIG No.: HRM 72A

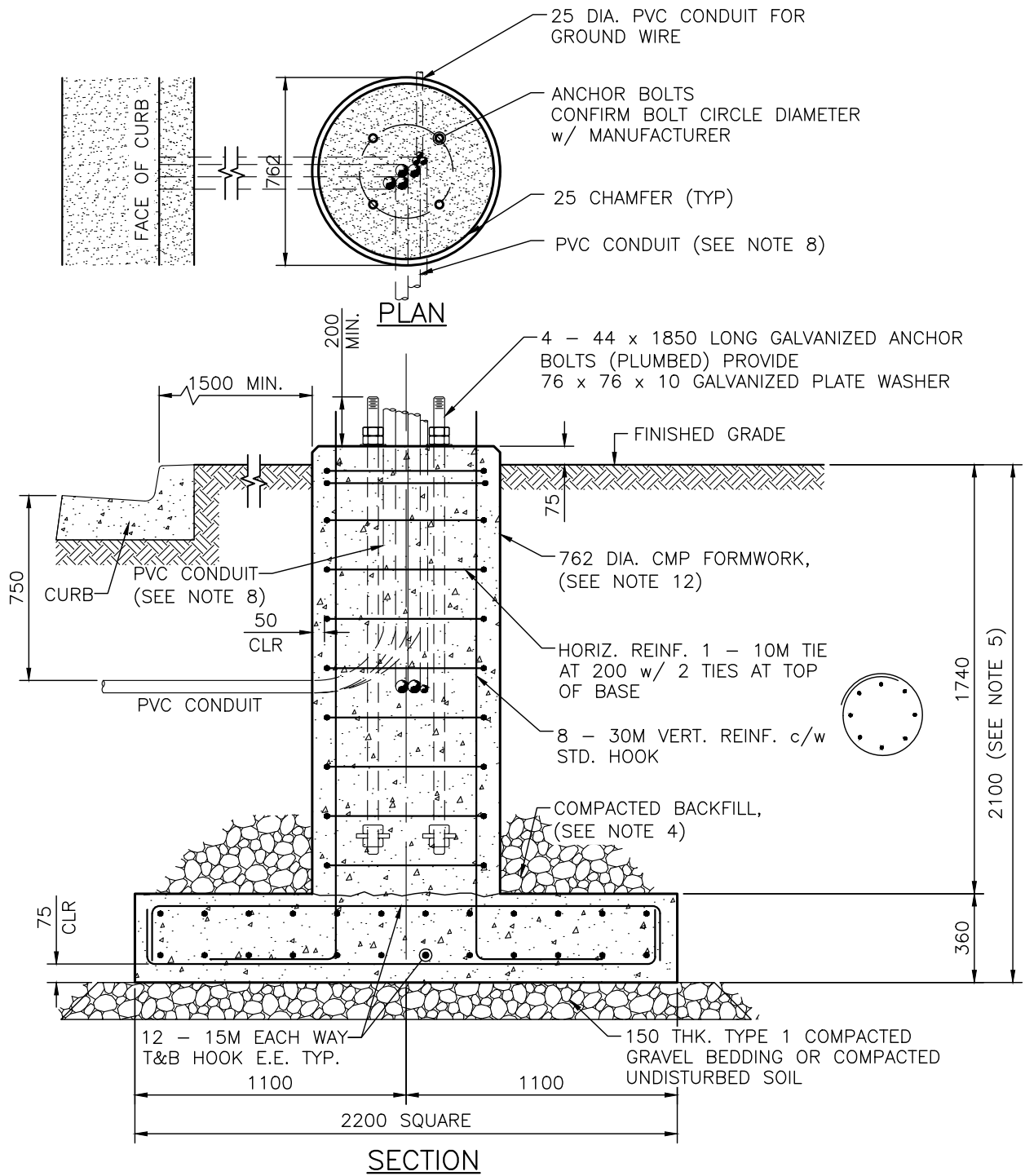

NOTES:

1. SEE HRM 68N3, SELECTION GUIDE, FOR PERMITTED POLES AND TRAFFIC SIGNAL EQUIPMENT.
2. FOR NOTES REFER TO HRM 68N2.
3. DIMENSIONS ARE IN MILLIMETRES.

HALIFAX		
STANDARD DETAIL		
TRAFFIC SIGNAL BASE FOR CONFIGURATION T, U AND V		
DATE:	REFERENCE	APPROVED
2021		
SCALE:		FIG No.:
1:25		HRM 73

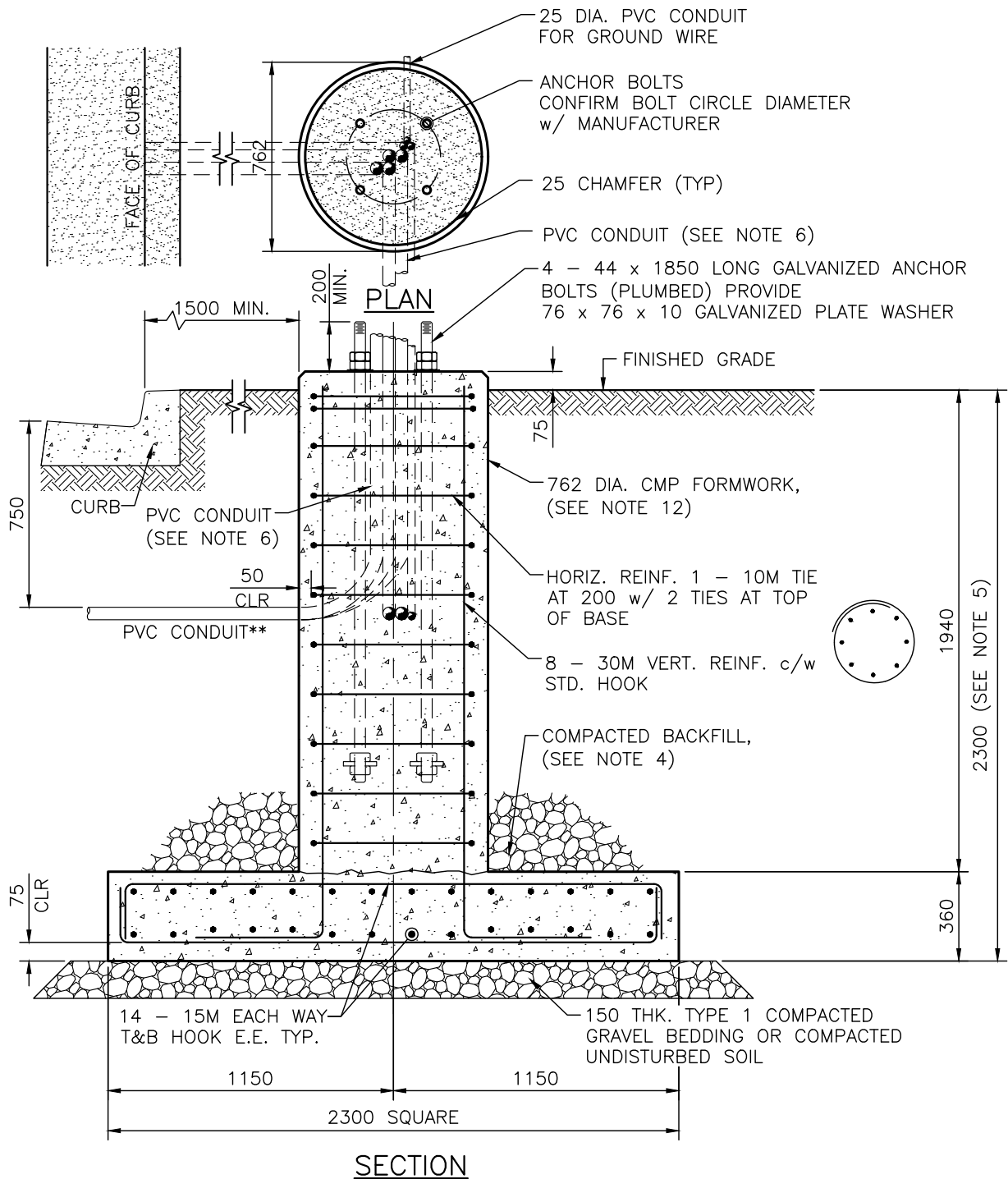

NOTES:

- SEE HRM 68N3, SELECTION GUIDE, FOR PERMITTED POLES AND TRAFFIC SIGNAL EQUIPMENT.
- FOR NOTES REFER TO HRM 68N2.
- DIMENSIONS ARE IN MILLIMETRES.

<h1>HALIFAX</h1>		
STANDARD DETAIL		
TRAFFIC SIGNAL BASE FOR CONFIGURATION W, X AND Y		
DATE:	2021	REFERENCE
SCALE:	1:25	APPROVED
		FIG No.: HRM 73A

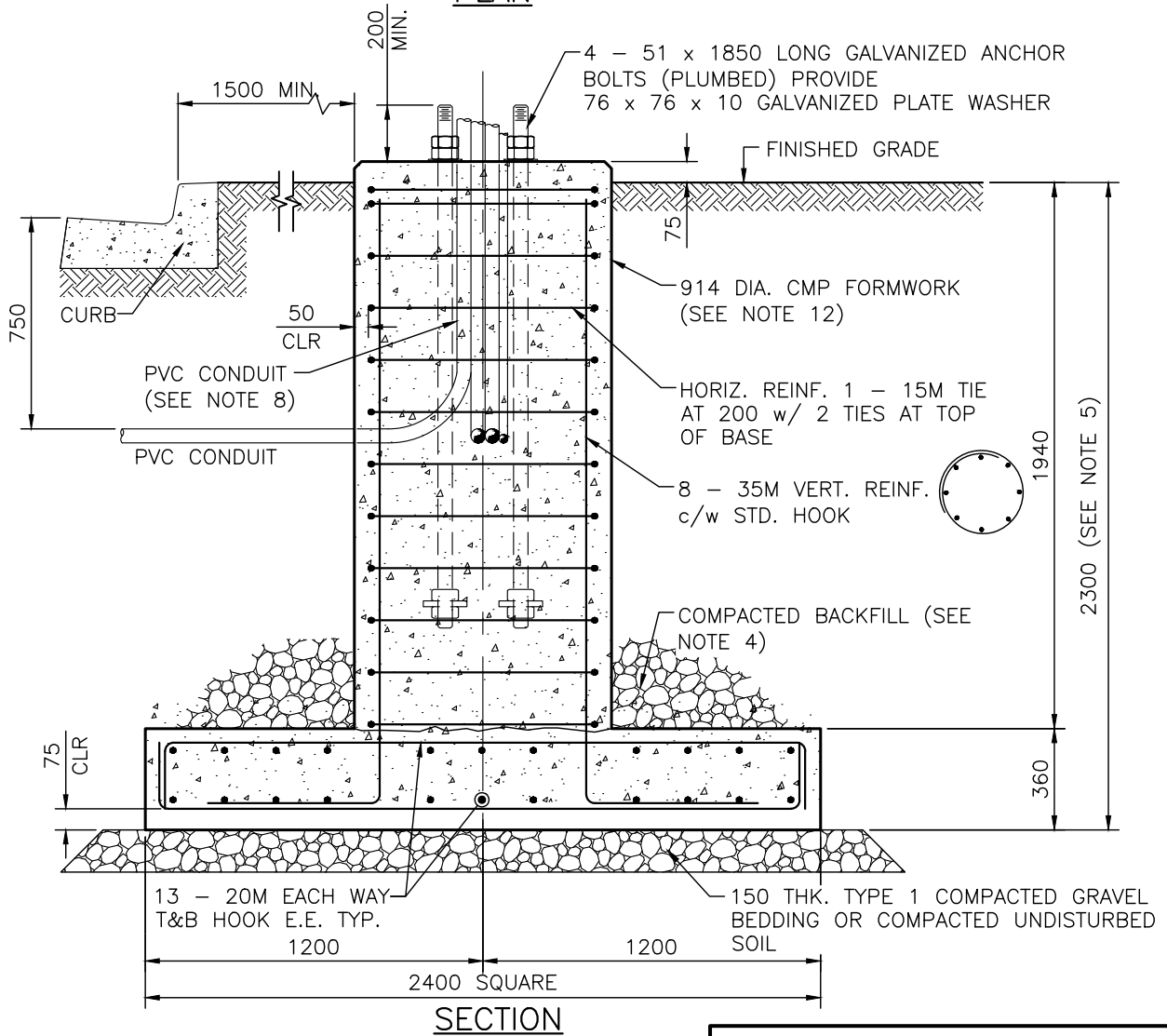
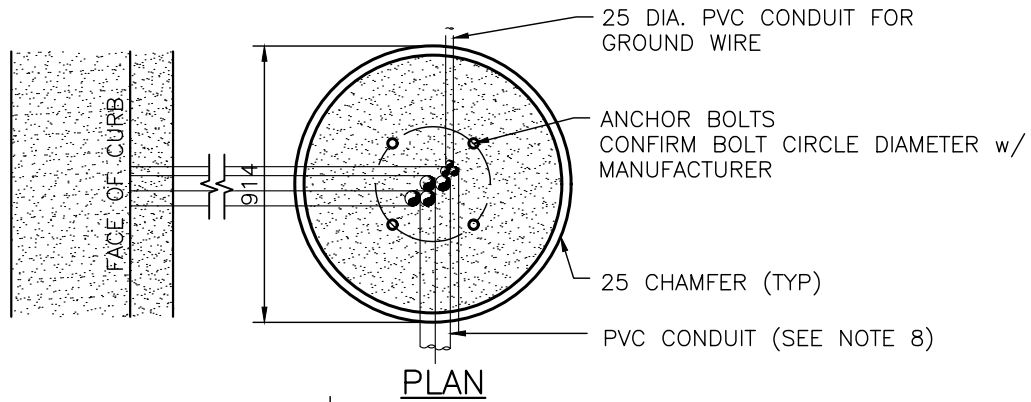

NOTES:

1. SEE HRM 68N3, SELECTION GUIDE, FOR PERMITTED POLES AND TRAFFIC SIGNAL EQUIPMENT.
2. FOR NOTES REFER TO HRM 68N2.
3. DIMENSIONS ARE IN MILLIMETRES.

HALIFAX

STANDARD DETAIL

TRAFFIC SIGNAL BASE FOR CONFIGURATION Z, AA AND AB

DATE:	2021	REFERENCE	APPROVED
SCALE:	1:25		FIG No.: HRM 74

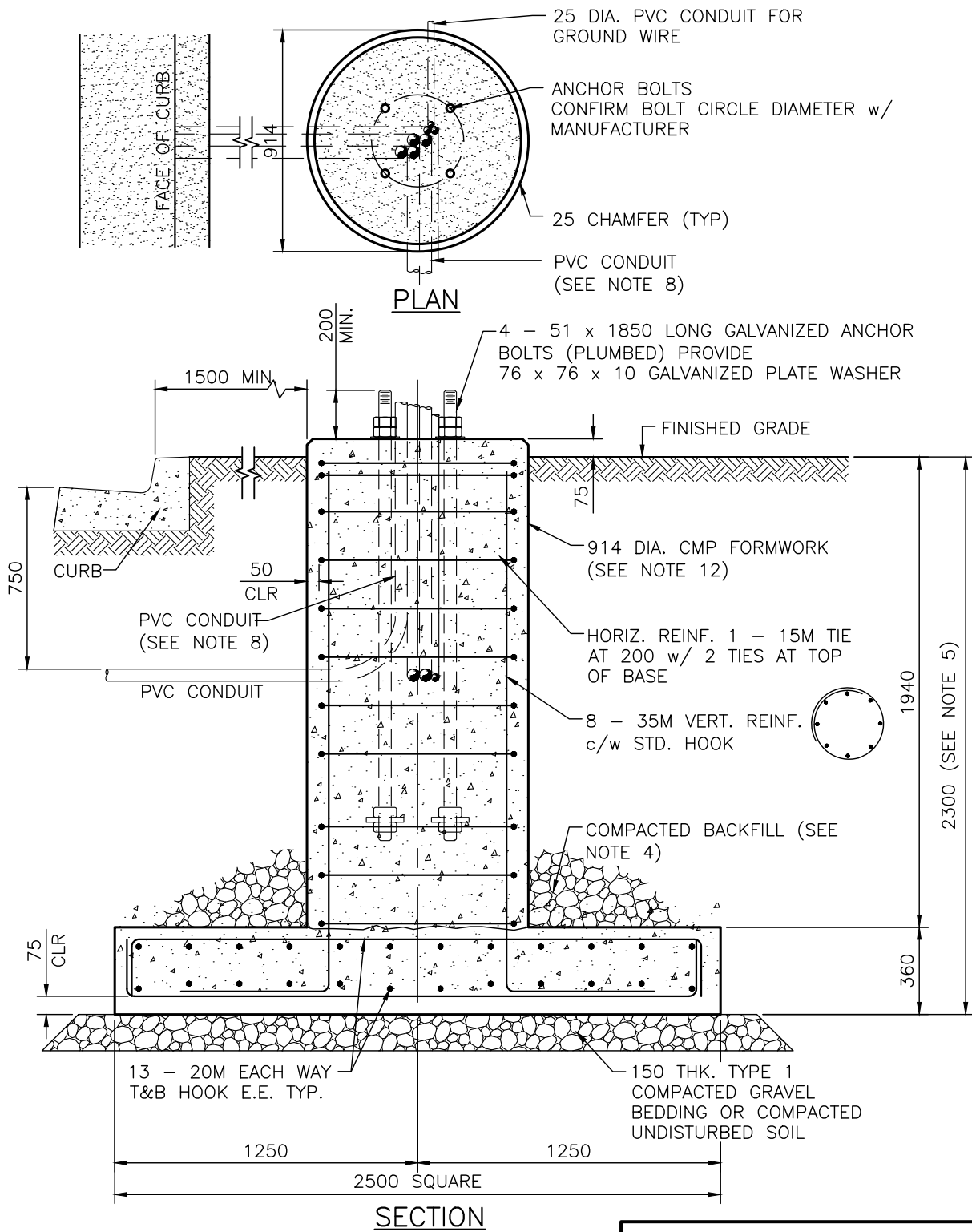

NOTES:

1. SEE HRM 68N3, SELECTION GUIDE, FOR PERMITTED POLES AND TRAFFIC SIGNAL EQUIPMENT.
2. FOR NOTES REFER TO HRM 68N2.
3. DIMENSIONS ARE IN MILLIMETRES.

<h1>HALIFAX</h1>		
STANDARD DETAIL		
TRAFFIC SIGNAL BASE FOR CONFIGURATION AC, AD AND AE		
DATE:	REFERENCE	APPROVED
2021		
SCALE:		FIG No.:
1:25		HRM 74A

DOWELS PLACED AT 90 DEG.

ANCHOR BOLTS (TYP.)

DOWELS PLACED AT 60 DEG.

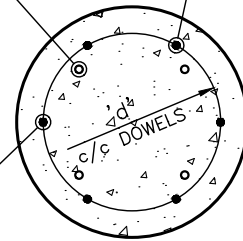
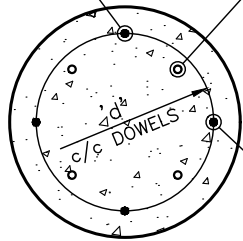

DOWELS (TYP.) DESIGN BASED ON COVER TO DOWELS = 80

SECTION 4 DOWELS

SECTION 6 DOWELS

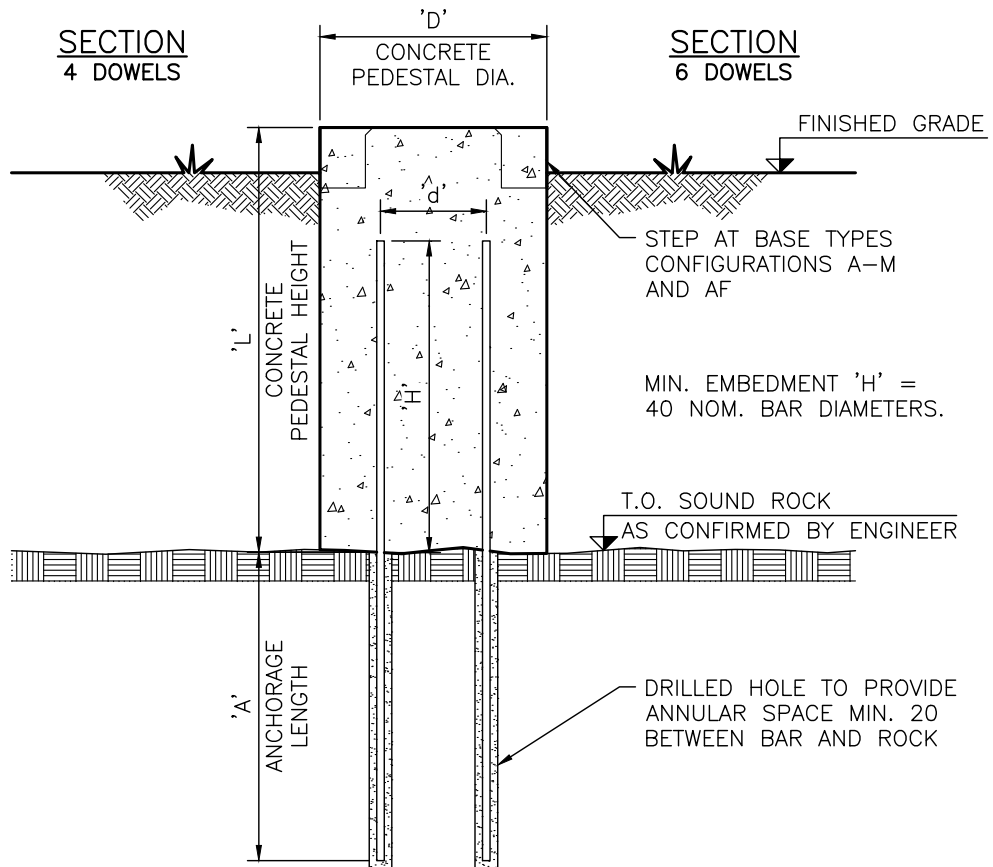

NOTE:

1. SEE HRM 74B.2 FOR ANCHORAGE DETAILS.
2. PEDESTAL REINFORCING NOT SHOWN FOR CLARITY.
3. ANCHOR BOLTS TO BE DESIGNED BY AND STAMPED BY AN ENGINEER LICENSED TO PRACTICE IN NS.

HALIFAX

STANDARD DETAIL

FOUNDATION REVISIONS FOR DOWELING INTO ROCK

DATE:	2021	REFERENCE	APPROVED
SCALE:	1:25		FIG No.: HRM 74B.1

ANCHORAGE SCHEDULE

REF. DWG.	'L' MIN.	'D'	'd'	'A' MIN	DOWELS
68	1200	610	425	2500	4 – 25M
69	1200	760	575	2500	4 – 25M
70, 71, 71A	1300	760	570	3000	4 – 30M
72, 72A	1500	760	565	3500	4 – 35M
73, 73A	1800	760	565	3500	6 – 35M
74, 74A	1800	910	715	4000	6 – 35M
74X	1300	760	570	3000	4 – 30M

NOTES:

1. SOUND ROCK TO BE CONFIRMED BY ENGINEER.
2. MIN. LENGTH 'L' IS REQUIRED TO SUIT LENGTH OF ANCHOR BOLTS.
3. DRILLED HOLE IN ROCK TO BE CLEAN AND DRY BEFORE GROUTING. GROUT TO BE MASTERFLOW 816 CABLE GROUT OR APPROVED EQUAL, INSTALLED IN ACCORDANCE WITH MANUFACTURER'S DIRECTIONS.
4. THIS DRAWING TO BE USED IN CONJUNCTION WITH HRM 74B.1.
5. ANCHOR BOLTS TO BE DESIGNED BY AND STAMPED BY AN ENGINEER LICENSED TO PRACTICE IN NS.

HALIFAX

STANDARD DETAIL

**FOUNDATION REVISIONS
FOR DOWELING INTO ROCK**

DATE:	2021	REFERENCE	APPROVED
SCALE:	NTS		FIG No.: HRM 74B.2

25 DIA. PVC CONDUIT**
FOR GROUND WIRE

ANCHOR BOLTS
CONFIRM BOLT CIRCLE DIAMETER w/
MANUFACTURER

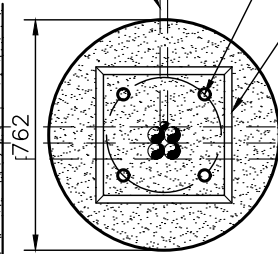
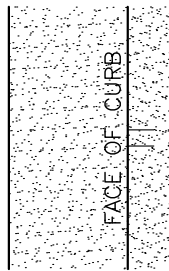

450 x 450 (OR 500 x 500) BASE
CAP MUST BE SQUARE WITH CURB
LINES AND POURED MONOLITHIC WITH
BASE

53 DIA. PVC CONDUIT (SEE NOTE 8)

SPARE 53 DIA. PVC
CONDUIT** (CAPPED)

PLAN

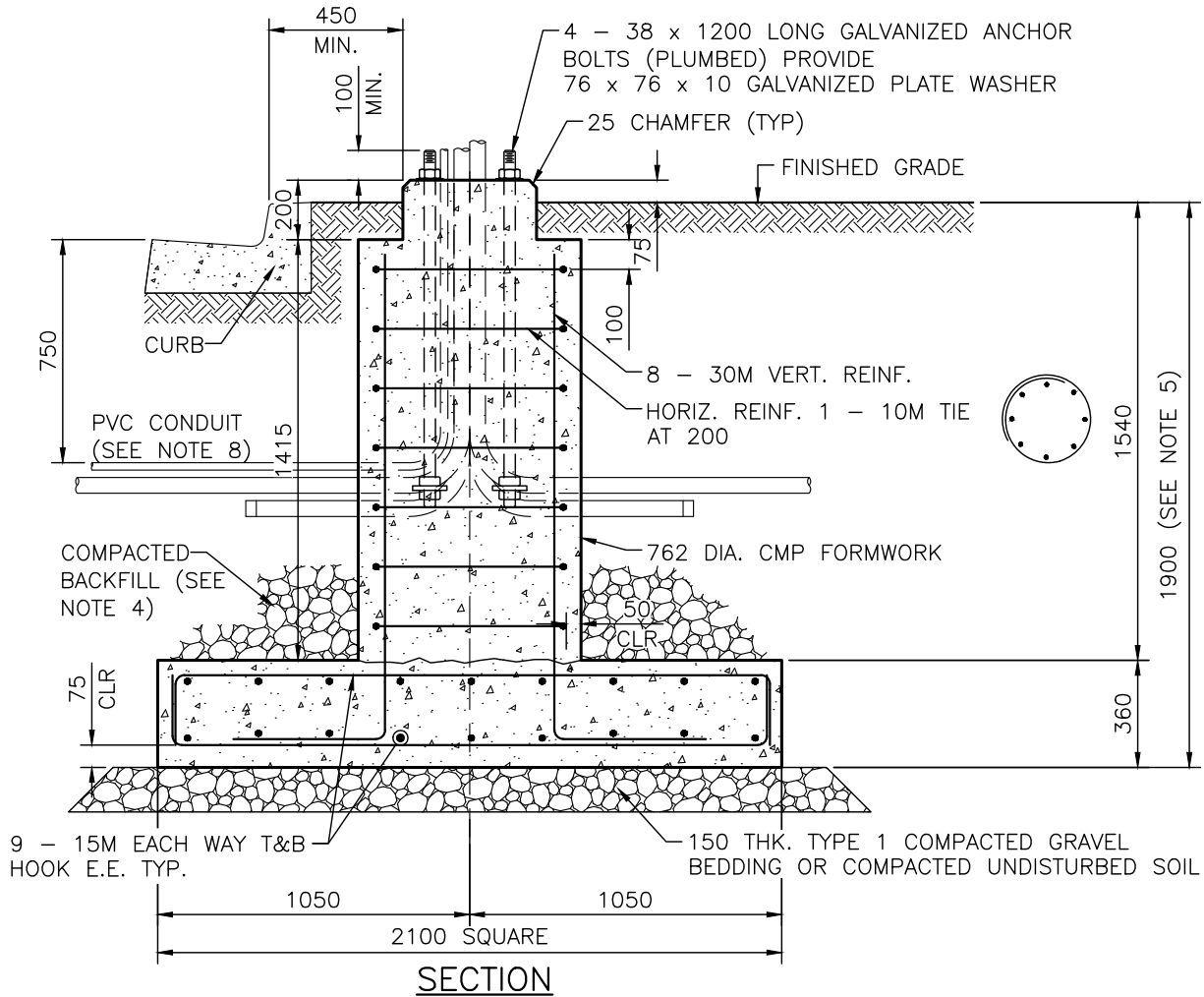

SECTION

NOTES:

1. SEE HRM 68N3, SELECTION GUIDE, FOR PERMITTED POLES AND TRAFFIC SIGNAL EQUIPMENT.
2. FOR NOTES REFER TO HRM 68N2.
3. DIMENSIONS ARE IN MILLIMETRES.

HALIFAX

STANDARD DETAIL

TRAFFIC SIGNAL BASE
FOR CONFIGURATION AF

DATE:	2021	REFERENCE	APPROVED
SCALE:	1:25		FIG No.: HRM 74X

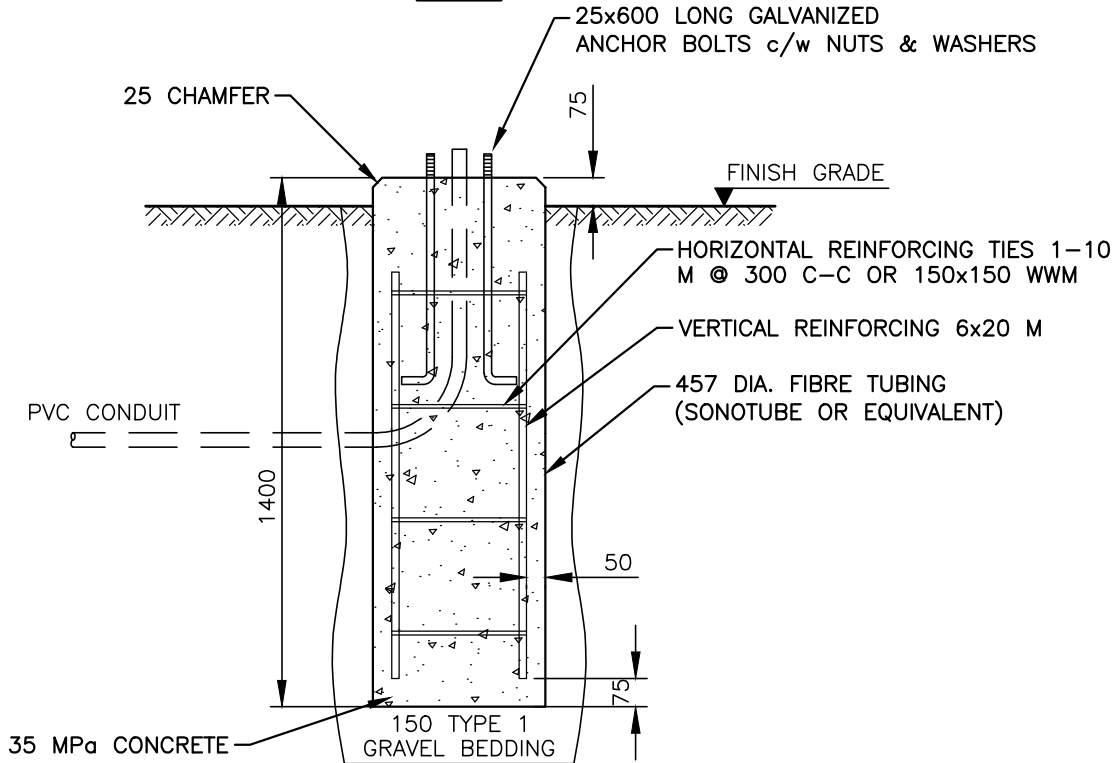
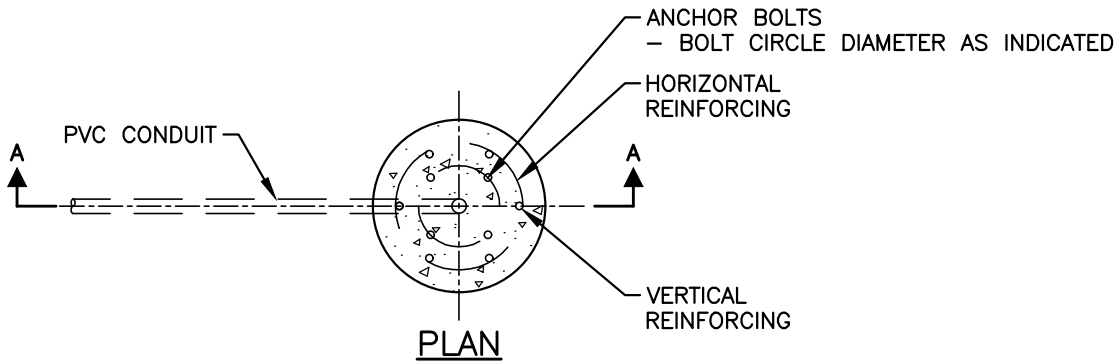

NOTES:

1. WHEN INSTALLED FOR ON STREET CYCLIST USE, PUSH BOTTOM HEIGHT TO BE 1100 mm FROM THE STREET SURFACE.
2. PROPOSED PVC CONDUIT SIZE AND CONFIGURATION INDICATED ON DRAWINGS.
3. ALL CONCRETE MUST BE PLACED IN A SINGLE POUR.
4. DIMENSIONS ARE IN MILLIMETRES.

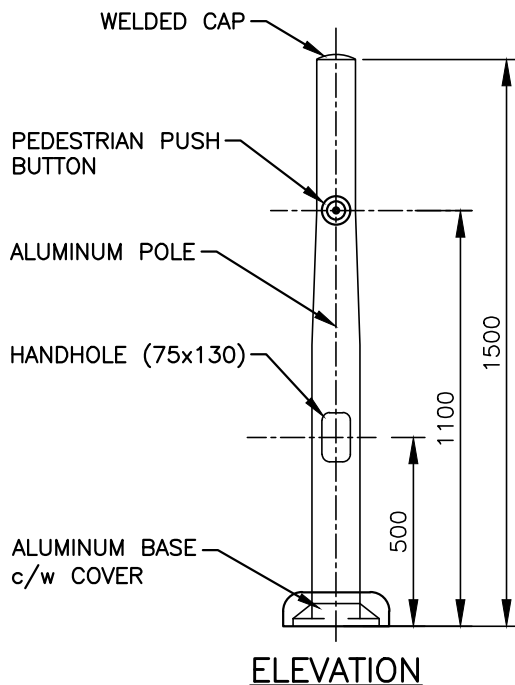

HALIFAX

STANDARD DETAIL

**PEDESTRIAN & CYCLIST PUSH
BUTTON POLE & BASE**

DATE:	2021	REFERENCE	APPROVED
SCALE:	1:20		FIG No.: HRM 75

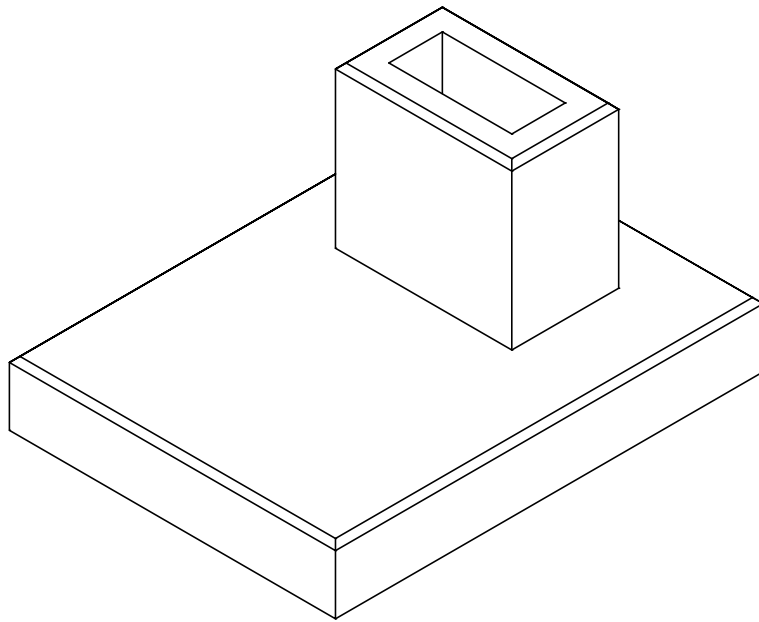

ISOMETRIC VIEW

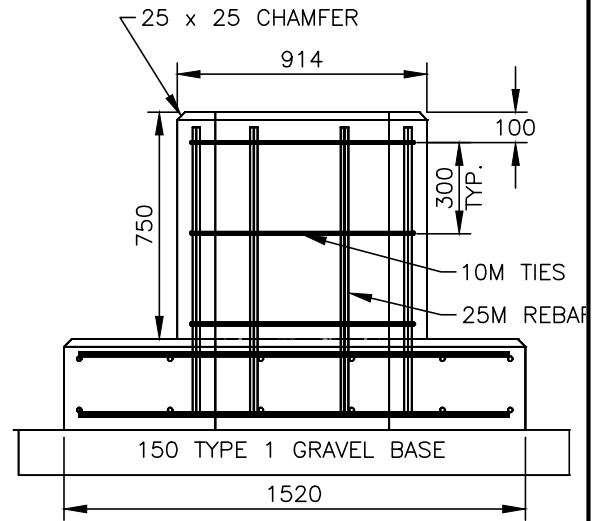

SIDE VIEW

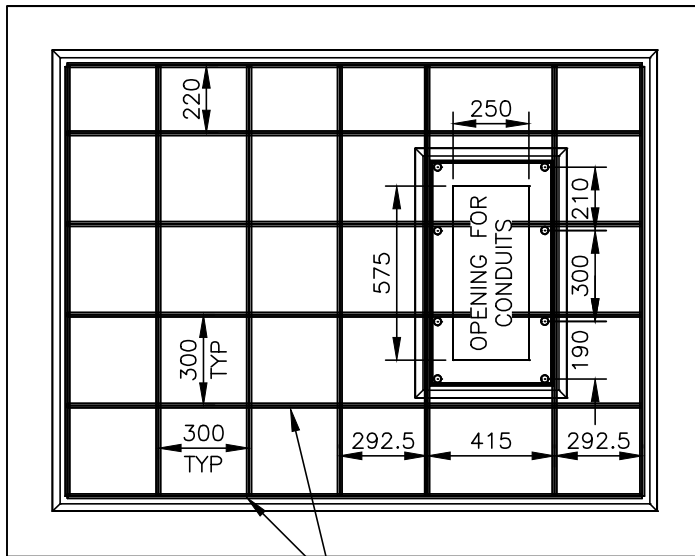

TOP VIEW

NOTES:

1. ALL CONCRETE SHALL BE 35 MPa.
2. PROVIDE MIN. 50 COVER FOR ALL REBAR.
3. PROVIDE GROUNDING FOR CABINET.
4. IN ADDITION TO CONDUIT SPECIFIED ON DRAWINGS, PROVIDE 2-50 mm DIA. PVC CONDUIT AND STUB OUTSIDE OF BASE.
5. ALL CONDUIT AND FITTINGS SHALL BE TO CANADIAN ELECTRICAL CODE.
6. PROVIDE 20 mm x 100 mm STAINLESS STEEL THREADED RODS TO CONNECT CONTROLLER CABINET.
7. ALL DIMENSIONS IN MILLIMETRES.
8. TYPE 1 GRAVEL BASE SHALL EXTEND MIN. 150 mm BEYOND EDGE OF BASE PAD.

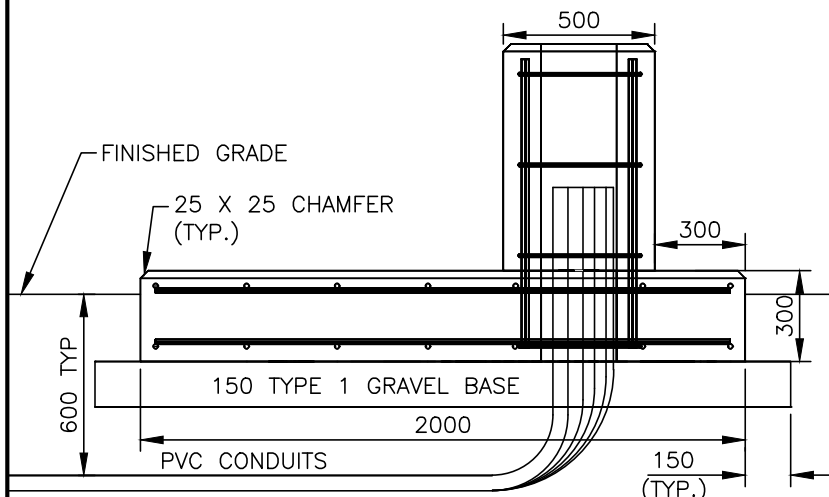

FRONT VIEW

HALIFAX

STANDARD DETAIL

**BASE MOUNTED TRAFFIC
SIGNAL CONTROLLER CABINET**

DATE:	2021	REFERENCE	APPROVED
SCALE:	NTS		FIG No.: HRM 76

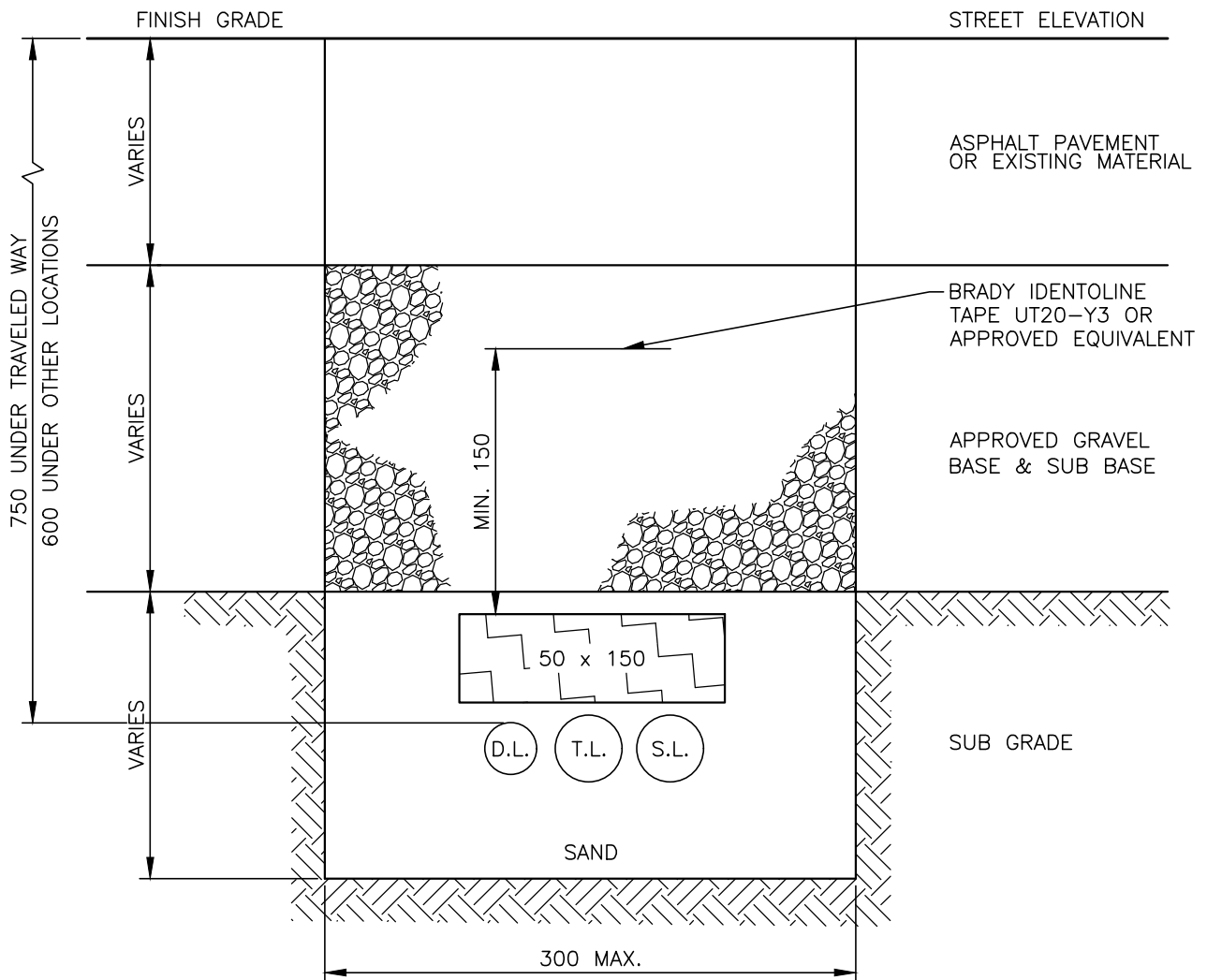

SIZE AND CONFIGURATION OF PVC CONDUIT INDICATED ON DRAWINGS

NOTES:

1. 50 mm x 150 mm WOOD PLANK TO BE PRESSURE TREATED WOOD.
2. "CAUTION BURIED ELECTRICAL LINE" TAPE TO BE PLACED OVER CONDUIT 150 mm TO 250 mm BELOW FINISHED GRADE.
3. SURROUND SAND WITH GEOTEXTILE SEPARATOR IN AREAS OF HIGH GROUNDWATER MOVEMENT (PERVIOUS SUB GRADE).

HALIFAX		
STANDARD DETAIL		
UNDERGROUND CONDUIT		
DATE:	REFERENCE	APPROVED
2021		
SCALE:		FIG No.:
NTS		HRM 78

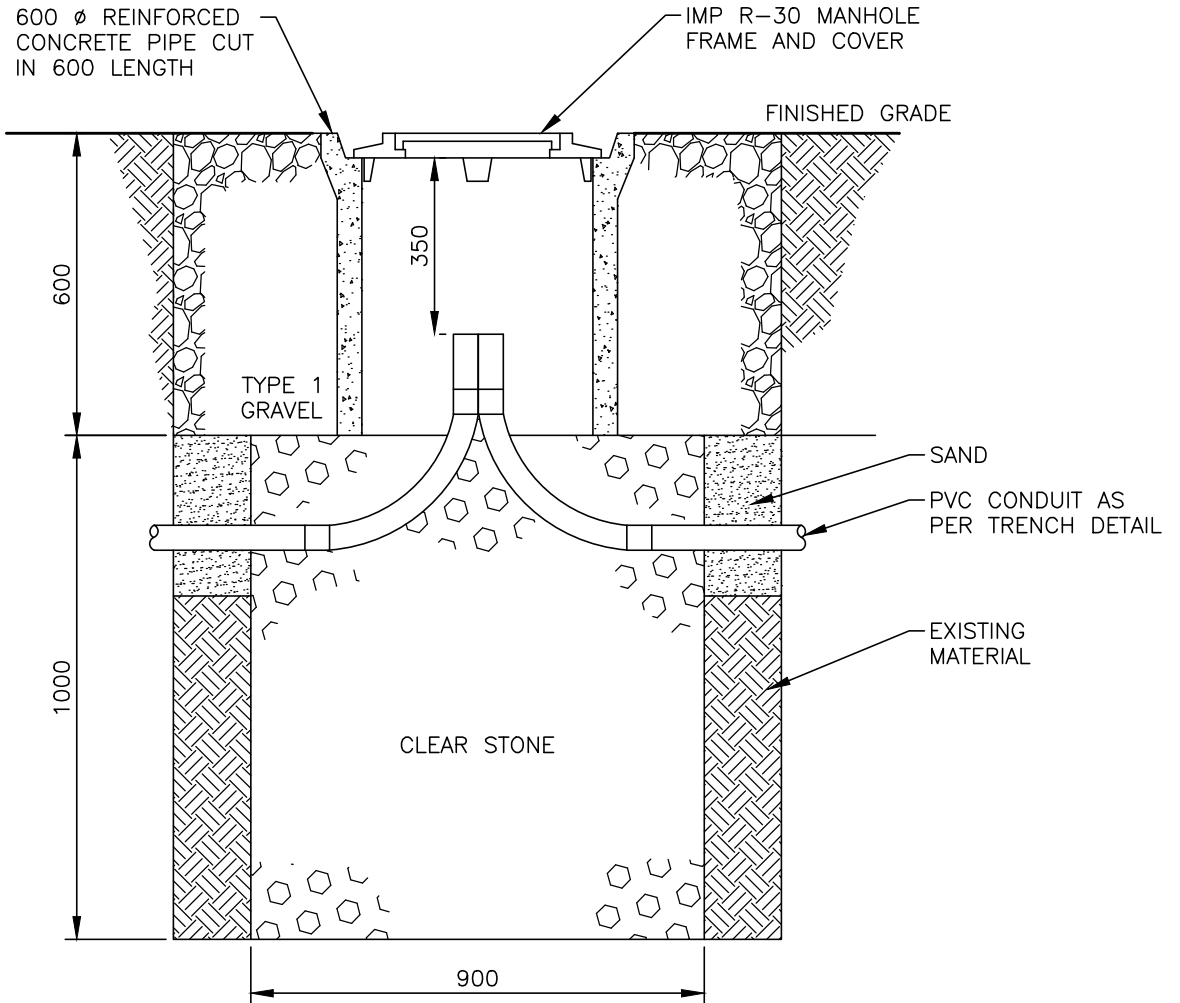

HALIFAX

STANDARD DETAIL

PULL PIT

DATE:	2021	REFERENCE	APPROVED
SCALE:	1:15		FIG No.: HRM 79

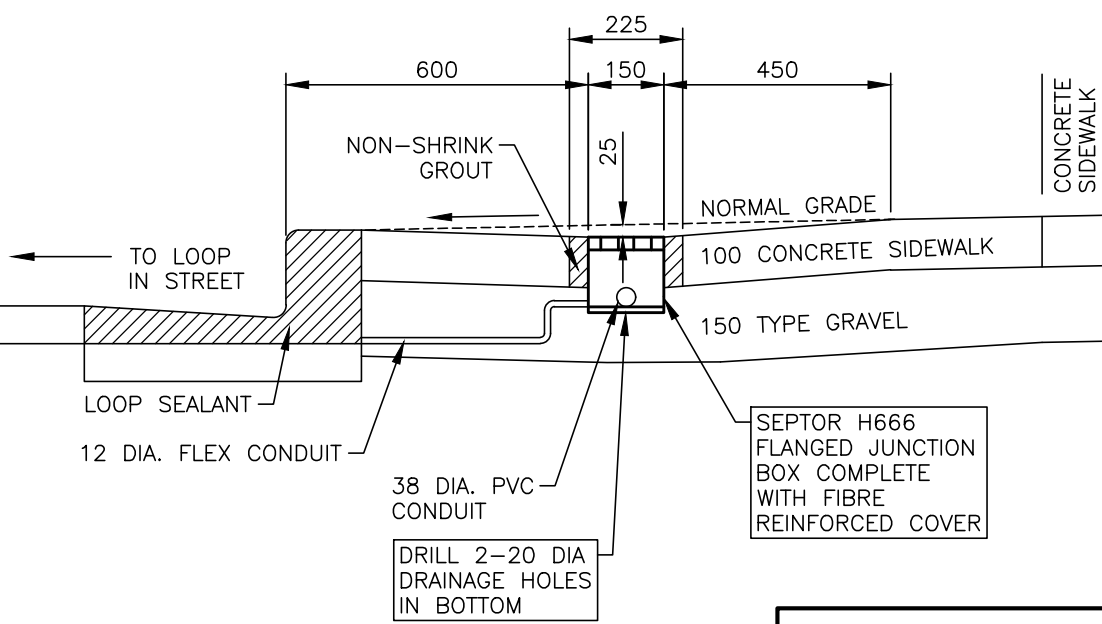
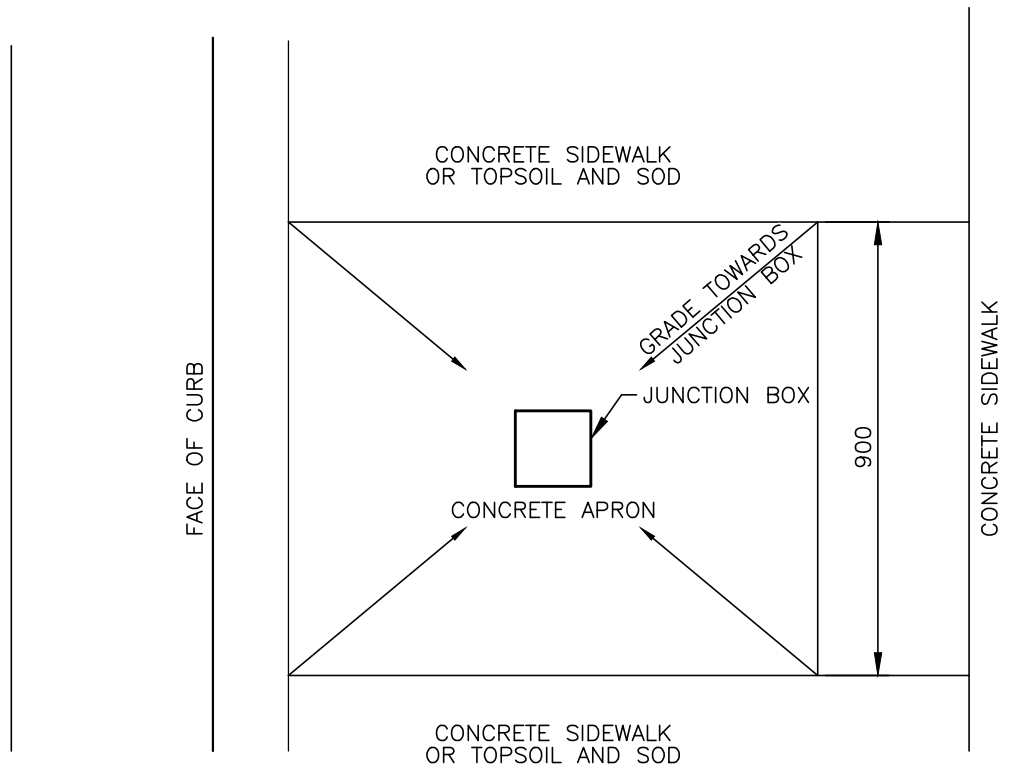

NOTES:

1. WHERE A TYPE A JUNCTION BOX – CONCRETE SIDEWALK IS TO BE INSTALLED NEXT TO A CURB WHERE THERE IS NO ADJACENT, A CONCRETE APRON IS NOT REQUIRED. THE JUNCTION BOX IS TO BE BURIED BENEATH THE TOPSOIL AND SOD.
2. ALL CONCRETE IS TO HAVE A MIN 35MP_a STRENGTH.

HALIFAX

STANDARD DETAIL

JUNCTION BOX TYPE "A"

DATE: 2021	REFERENCE	APPROVED
SCALE: NTS		FIG No.: HRM 80

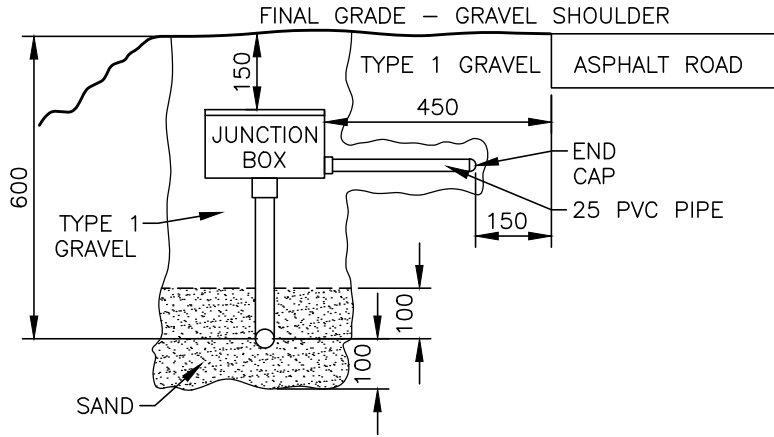

TYPE B
JUNCTION BOX CROSS SECTION - NO CURB
IPEX BRAND JB884 OR JB887 AS SPECIFIED

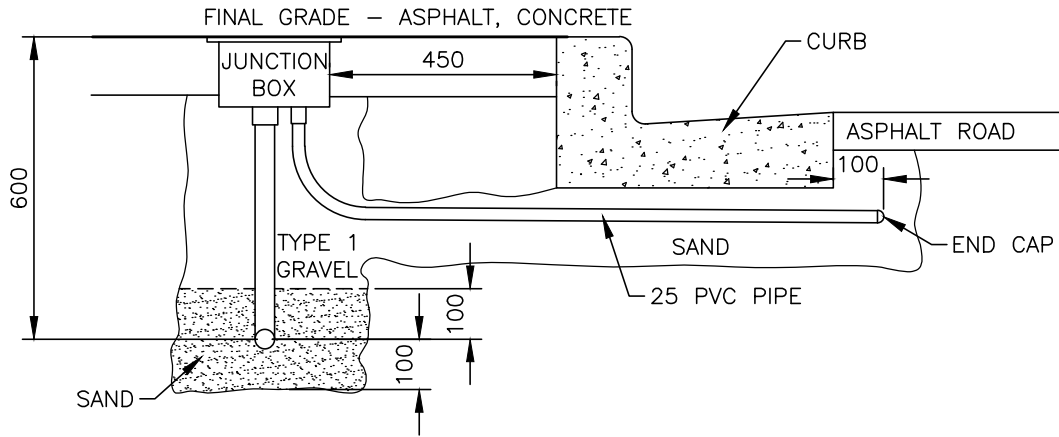

TYPE C
JUNCTION BOX CROSS SECTION - SURFACE MOUNT
IPEX BRAND H884 OR H887 AS SPECIFIED

NOTES:

1. WHERE A JUNCTION BOX IS TO BE INSTALLED NEXT TO A CURB WHERE THERE IS NO ADJACENT SIDEWALK, A CONCRETE APRON IS NOT REQUIRED. THE JUNCTION BOX IS TO BE BURIED BENEATH THE TOPSOIL AND SOD.
2. ALL CONCRETE IS TO HAVE A MIN 35MPa STRENGTH.

HALIFAX

STANDARD DETAIL

JUNCTION BOX
TYPE "B" & "C"

DATE:	2021	REFERENCE	APPROVED
SCALE:	NTS		FIG No.: HRM 81

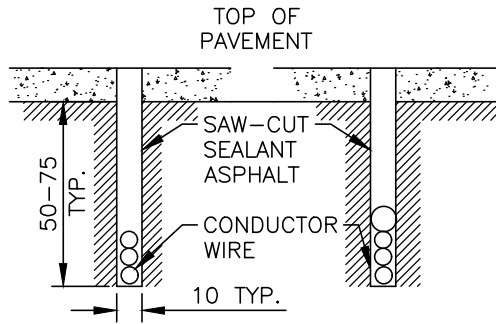

**TYPICAL SAW-CUT
CROSS SECTION**

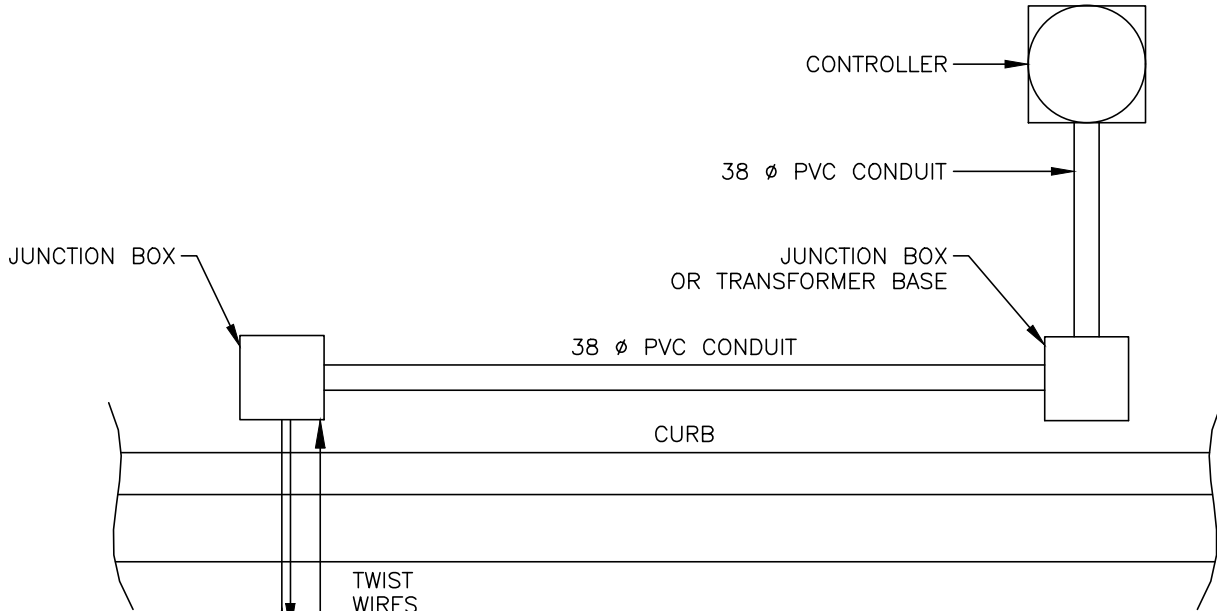

PLAN VIEW

LOOP AREA (L X W) SQ. METRES	NO. OF TURNS
0.5 TO 1.0	6
1.0 TO 2.0	5
2.0 TO 5.5	4
5.5 TO 22.0	3
22.0 PLUS	2

NOTES:

1. UNLESS OTHERWISE DIRECTED BY ENGINEER, LAY LOOPS IN A CLOCKWISE DIRECTION.
2. DEPTH OF SAW CUT TO BE CONSTANT AND PROVIDE A MINIMUM OF 50 mm COVER OVER TOP OF WIRE.

HALIFAX

STANDARD DETAIL

**DETECTOR LOOP
SAW CUT**

DATE:	2021	REFERENCE	APPROVED
SCALE:	NTS		FIG No.: HRM 82

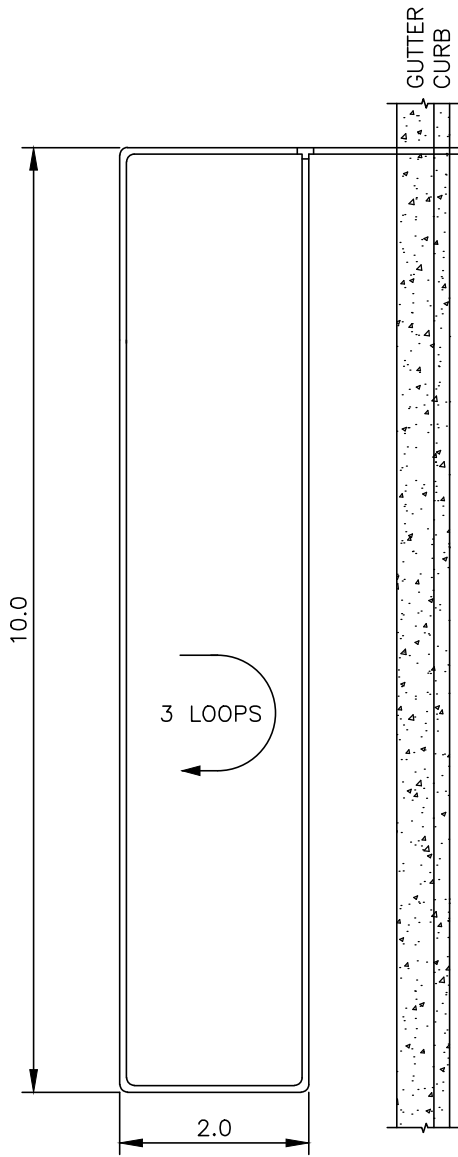

TYPICAL 2 X 10 PRE-FORMED LOOP

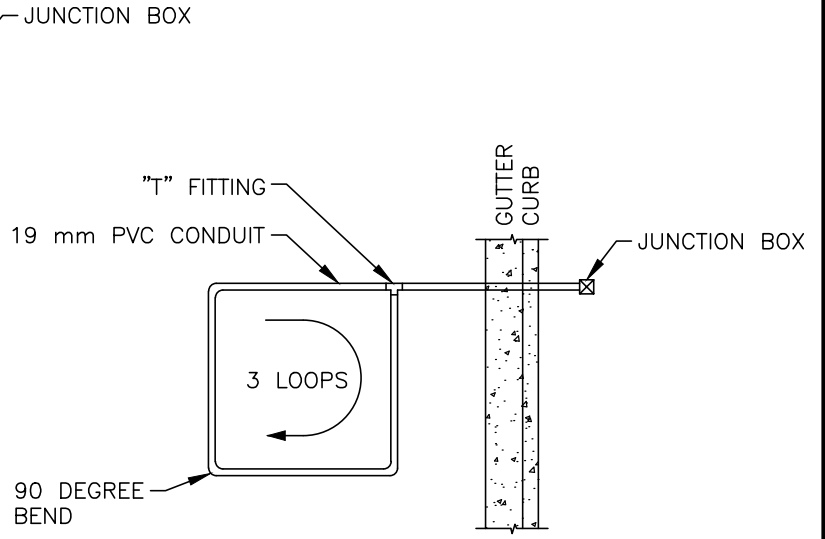

TYPICAL PRE-FORMED LOOP

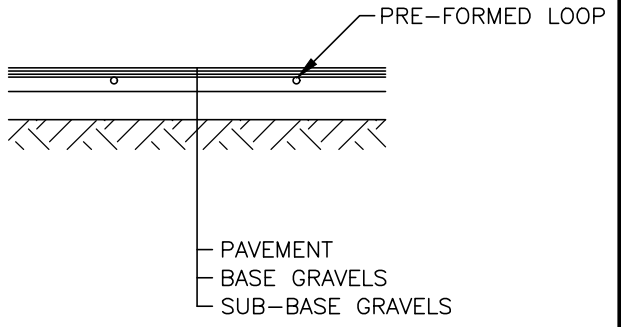

TYPICAL CROSS SECTION

NOTE:

ALL PVC CONNECTIONS BETWEEN PREFORMED LOOP AND JUNCTION BOX ARE TO BE MADE PRIOR TO PAVING. ANY DAMAGE TO THE PVC OR LOOP WIRES PRIOR TO PAVING WILL BE CAUSE TO REJECT THE LOOP.

HALIFAX

STANDARD DETAIL

**PRE-FORMED
DETECTOR LOOP**

DATE:	2021	REFERENCE	APPROVED
SCALE:	NTS		FIG No.: HRM 83

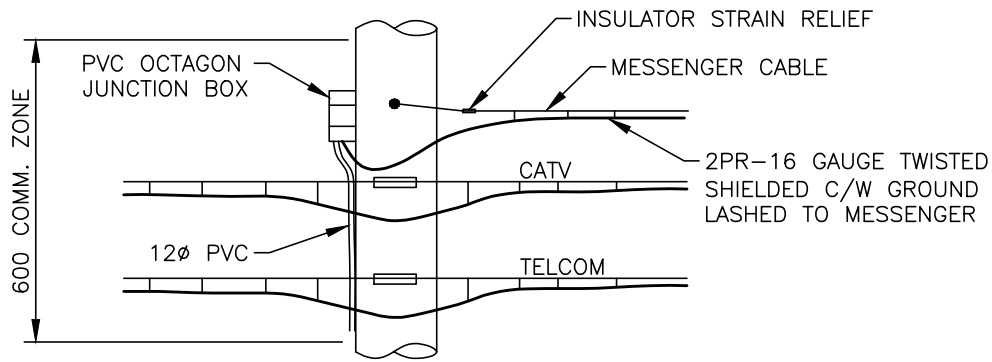

DETAIL 'A'
LOOP POLE

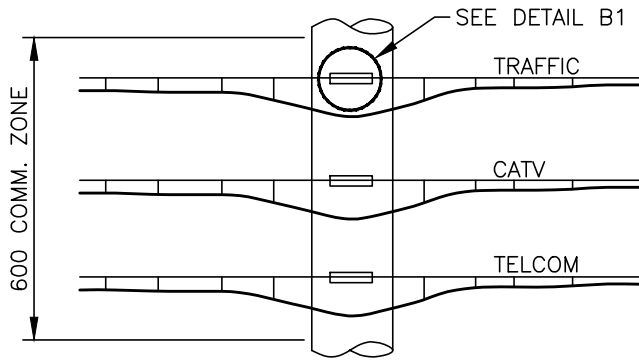

DETAIL 'B'
MID RUN SUPPORT

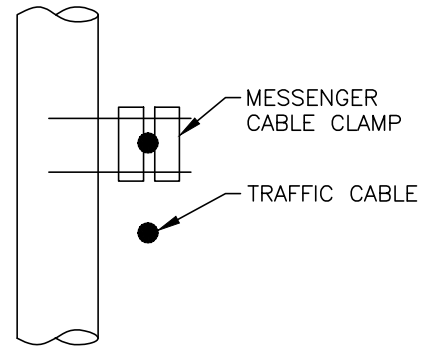

DETAIL 'B1'
SUPPORT BRACKET

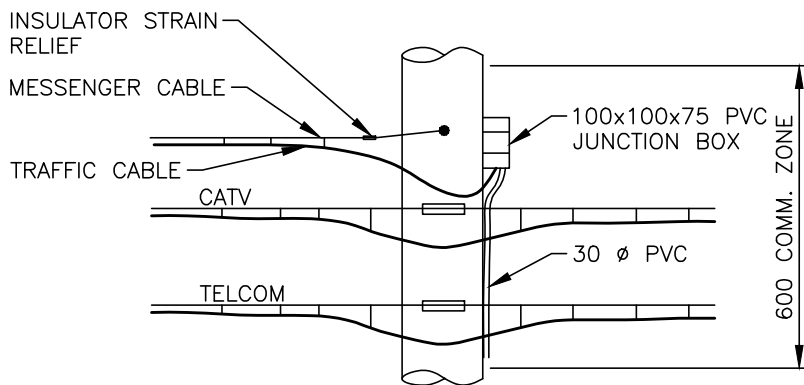

DETAIL 'C'
CONTROLLER POLE

HALIFAX

STANDARD DETAIL

**POLE MOUNT DETAILS FOR
DETECTOR LOOP INSTALLATION**

DATE:	2021	REFERENCE	APPROVED
SCALE:	NTS		FIG No.: HRM 84

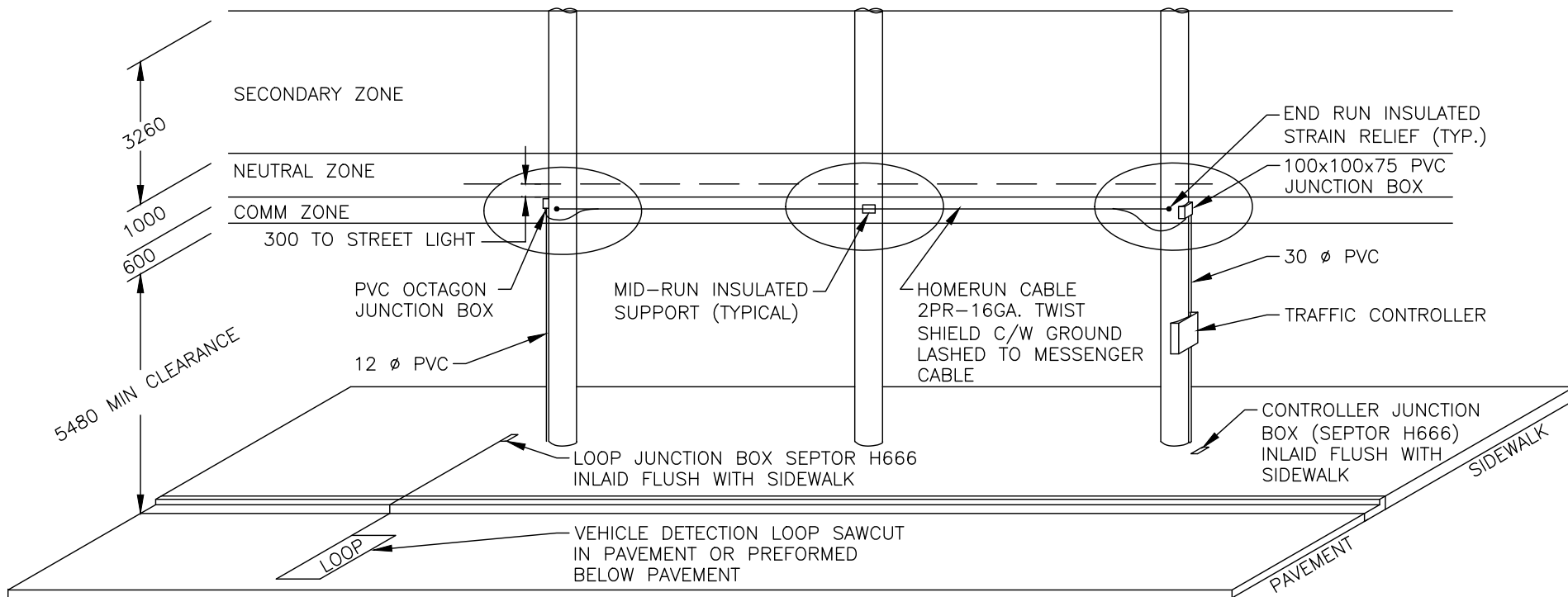

HALIFAX

STANDARD DETAIL

POLE MOUNT
HOME RUN

DATE:	2021	REFERENCE	APPROVED
SCALE:	NTS		FIG No.:
			HRM 85

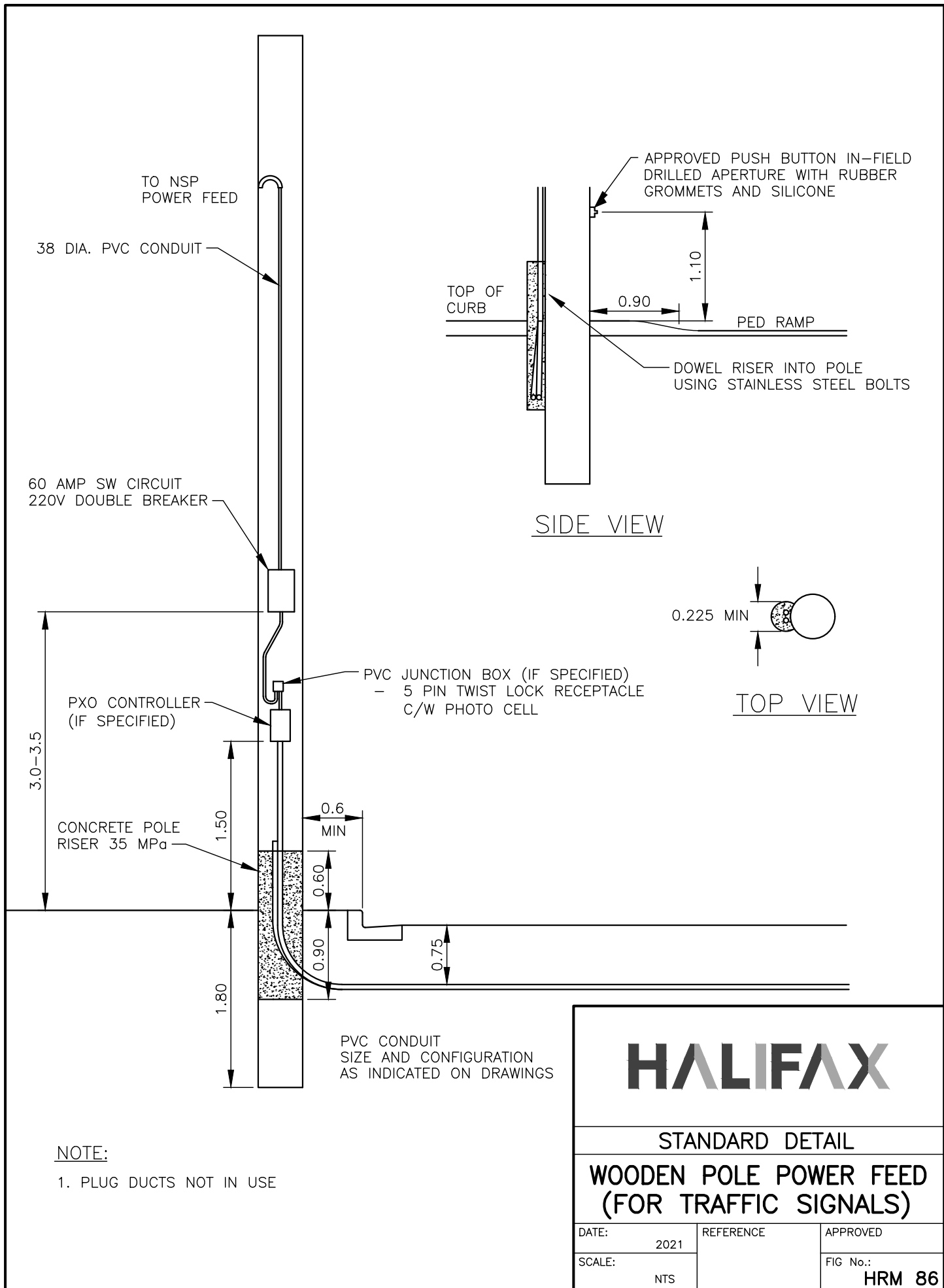

NOTE:

1. PLUG DUCTS NOT IN USE

<h1>HALIFAX</h1>		
STANDARD DETAIL		
WOODEN POLE POWER FEED (FOR TRAFFIC SIGNALS)		
DATE:	REFERENCE	APPROVED
2021		
SCALE:		FIG No.:
NTS		HRM 86

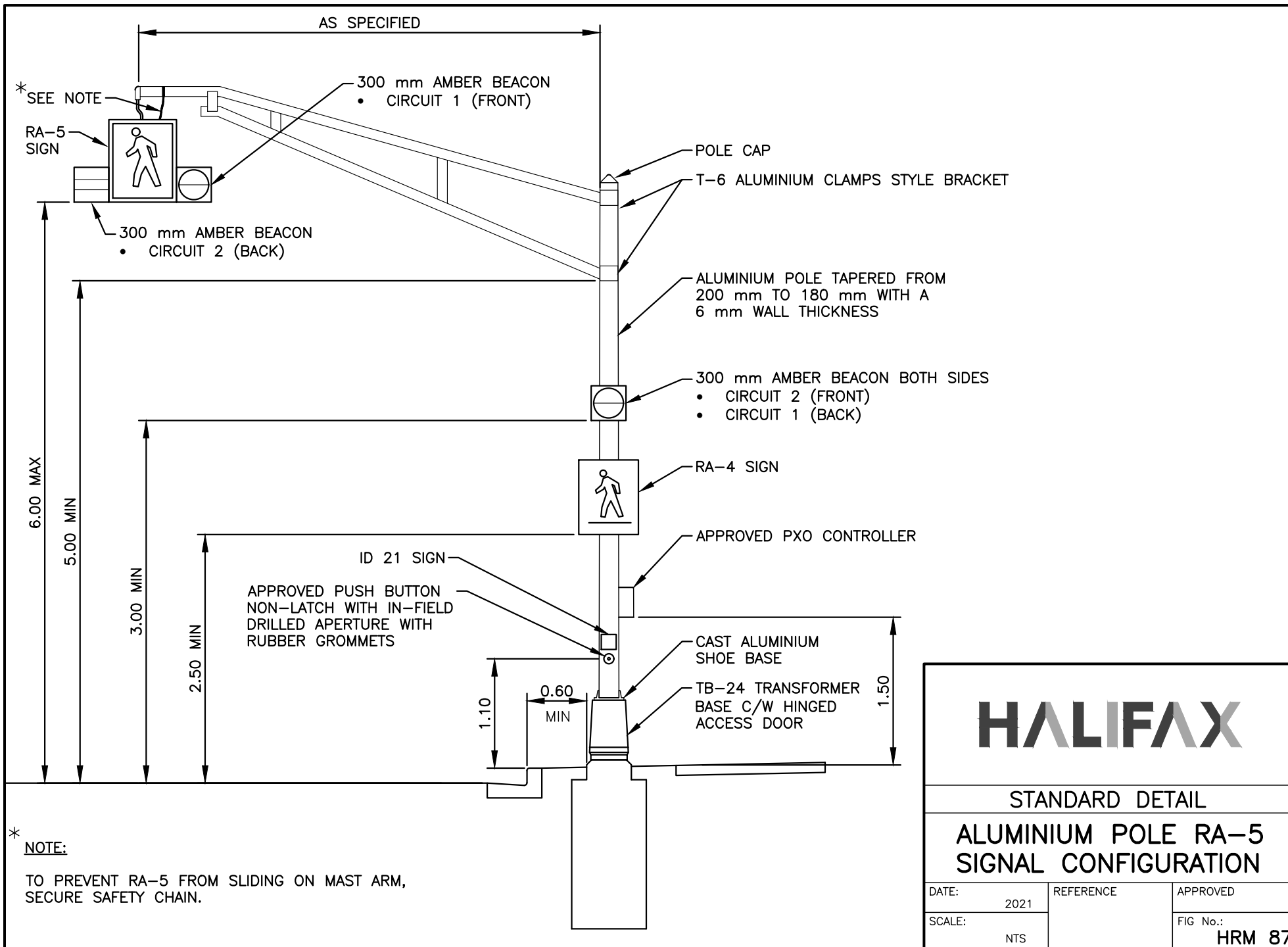

HALIFAX

STANDARD DETAIL

ALUMINIUM POLE RA-5 SIGNAL CONFIGURATION

DATE:	2021	REFERENCE	APPROVED
SCALE:	NTS	FIG No.:	HRM 87

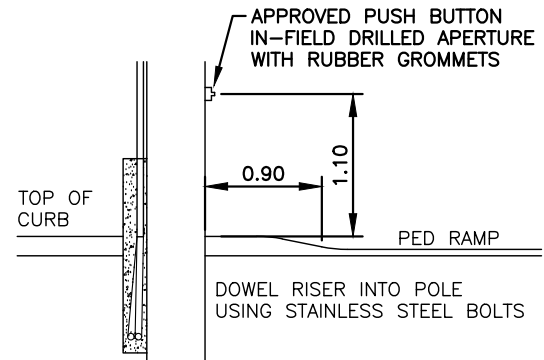
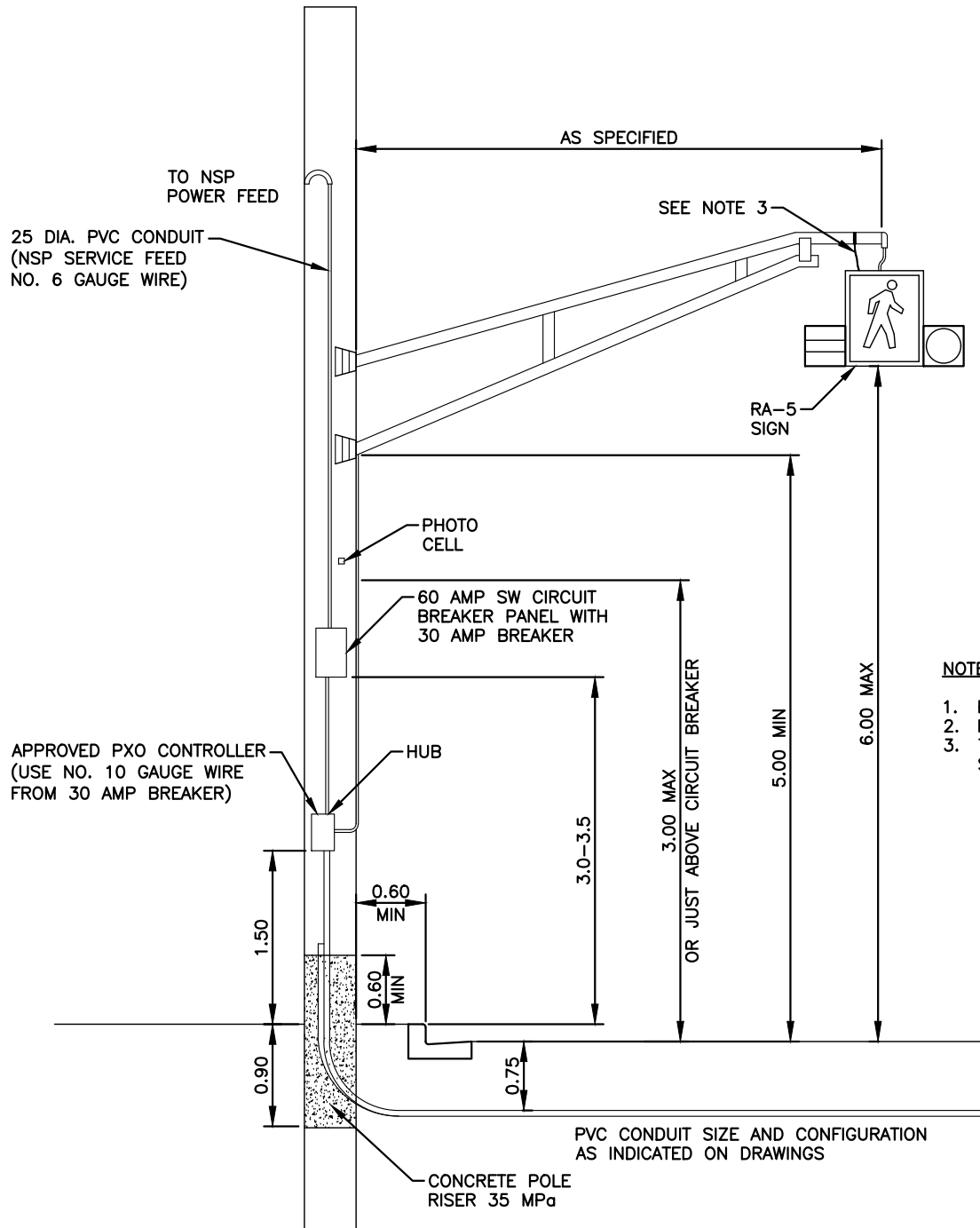

SIDE VIEW

TOP VIEW

NOTES:

1. PLUG DUCTS NOT IN USE
2. INSTALL MUTCD ID21 SIGN JUST ABOVE PUSH BUTTON
3. TO PREVENT RA-5 FROM SLIDING ON MAST ARM, SECURE SAFETY CHAIN.

HALIFAX

**STANDARD DETAIL
WOODEN POLE RA-5
TRAFFIC SIGNAL WITH POWER
FEED CONFIGURATION**

DATE:	2021	REFERENCE	APPROVED
SCALE:	NTS	FIG No.:	HRM 88

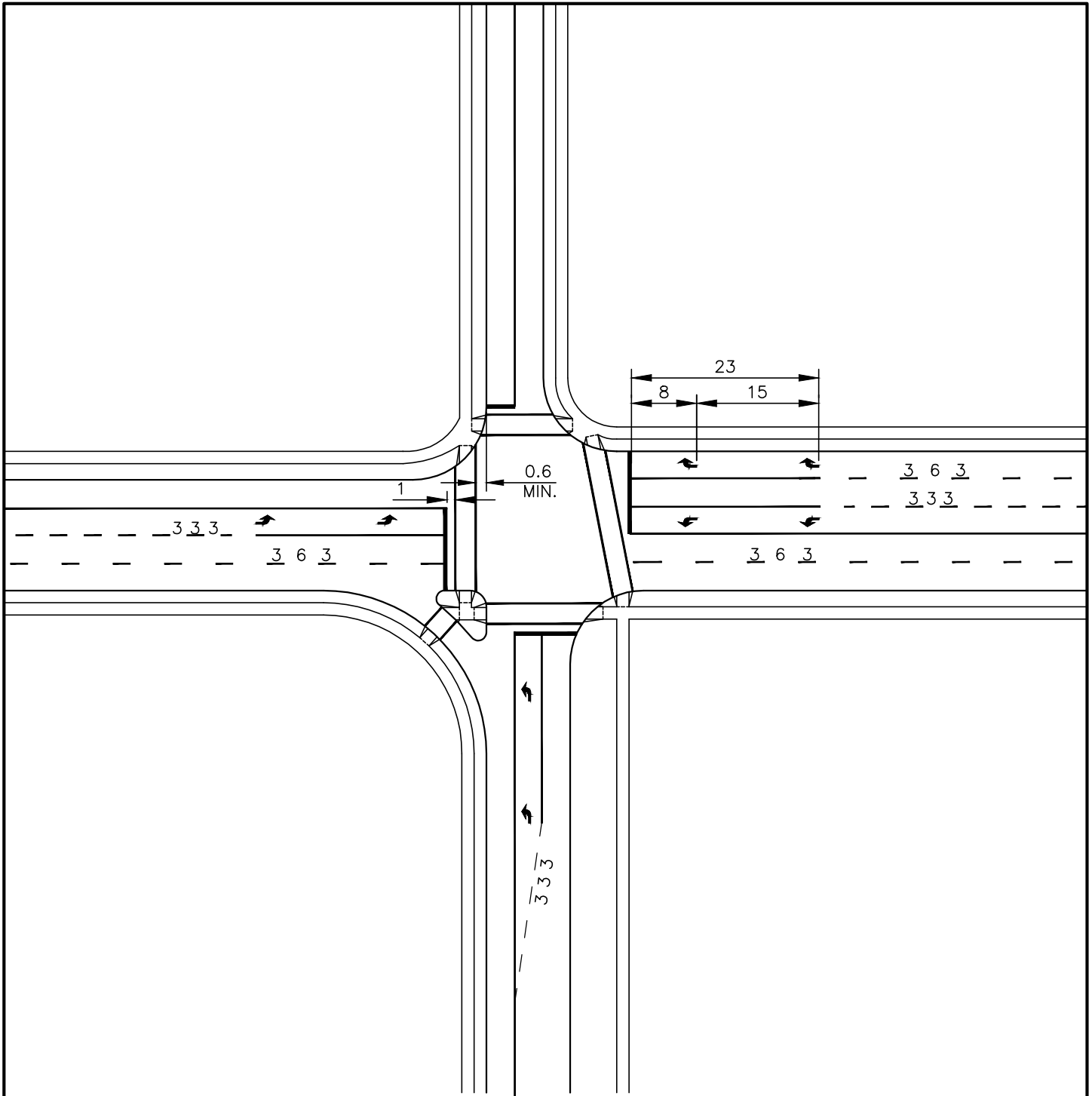

NOTES:





1. ALL PAVEMENT MARKINGS SHALL BE IN ACCORDANCE WITH HRM STANDARD DETAILS.
2. WHEN REQUIRED, THIRD AND SUBSEQUENT ARROWS TO BE SPACED AT 15.0 m INTERVALS.

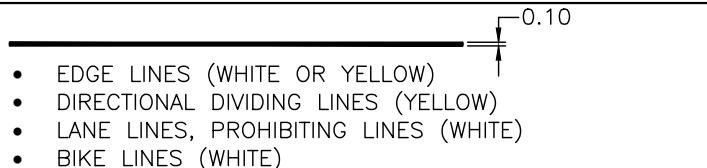
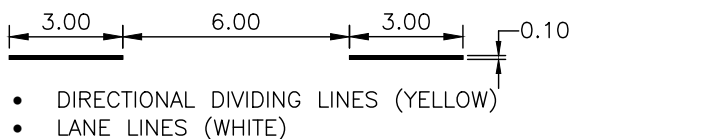
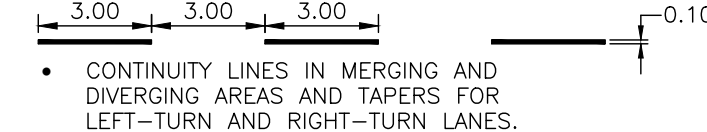
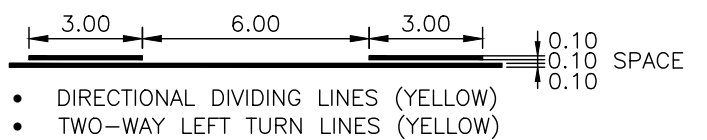

HALIFAX

STANDARD DETAIL

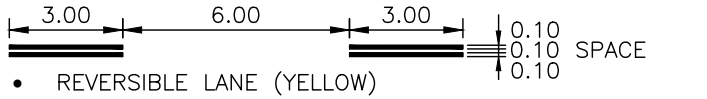
STANDARD INTERSECTION PAVEMENT MARKING LAYOUT

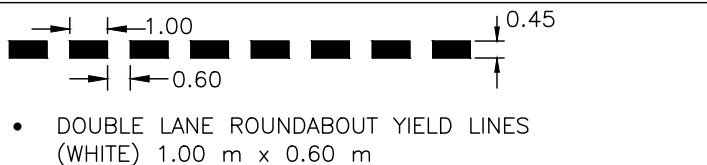
DATE:	2021	REFERENCE	APPROVED
SCALE:	NTS		FIG No.: HRM 89

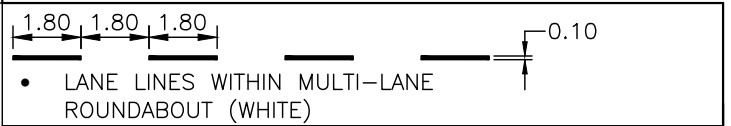
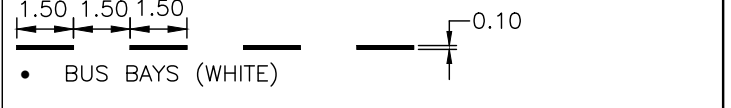
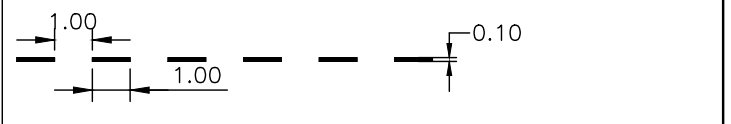
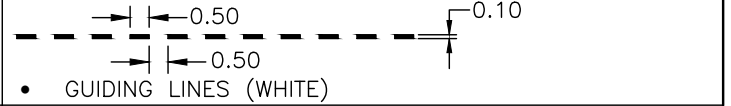
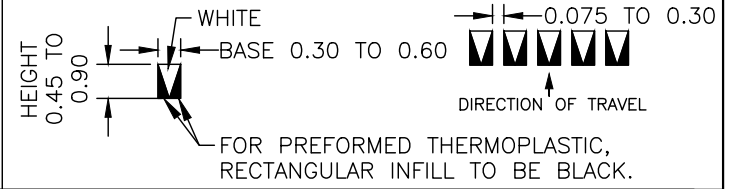
NAME OF LINE	
SOLID	 <ul style="list-style-type: none"> EDGE LINES (WHITE OR YELLOW) DIRECTIONAL DIVIDING LINES (YELLOW) LANE LINES, PROHIBITING LINES (WHITE) BIKE LINES (WHITE)
3 m x 6 m BROKEN	 <ul style="list-style-type: none"> DIRECTIONAL DIVIDING LINES (YELLOW) LANE LINES (WHITE)
3 m x 3 m	 <ul style="list-style-type: none"> CONTINUITY LINES IN MERGING AND DIVERGING AREAS AND TAPERS FOR LEFT-TURN AND RIGHT-TURN LANES.
SIMULTANEOUS SOLID & BROKEN	 <ul style="list-style-type: none"> DIRECTIONAL DIVIDING LINES (YELLOW) TWO-WAY LEFT TURN LINES (YELLOW)
DOUBLE SOLID	 <ul style="list-style-type: none"> DIRECTIONAL DIVIDING LINES (YELLOW)
DOUBLE BROKEN 3 m x 6 m	 <ul style="list-style-type: none"> REVERSIBLE LANE (YELLOW)
YIELD	 <ul style="list-style-type: none"> SINGLE LANE ROUNDABOUT YIELD LINES (WHITE) 0.60 m x 0.60 m
	 <ul style="list-style-type: none"> DOUBLE LANE ROUNDABOUT YIELD LINES (WHITE) 1.00 m x 0.60 m

NAME OF LINE	
1.8 m x 1.8 m	 <ul style="list-style-type: none"> LANE LINES WITHIN MULTI-LANE ROUNDABOUT (WHITE)
1.5 m x 1.5 m	 <ul style="list-style-type: none"> BUS BAYS (WHITE)
DASHED 1.0 m x 1.0 m	
0.5 m x 0.5 m	 <ul style="list-style-type: none"> GUIDING LINES (WHITE)
ADVANCED YIELD TO PEDESTRIANS LINE	 <p>HEIGHT 0.45 TO 0.90</p> <p>WHITE</p> <p>BASE 0.30 TO 0.60</p> <p>0.075 TO 0.30</p> <p>DIRECTION OF TRAVEL</p> <p>FOR PREFORMED THERMOPLASTIC, RECTANGULAR INFILL TO BE BLACK.</p>
STOP BAR	 <ul style="list-style-type: none"> INTERSECTION STOP BAR (WHITE)

NOTE:

1. DIMENSIONS ARE IN METRES.

HALIFAX

STANDARD DETAIL

LONGITUDINAL & TRANSVERSE
PAVEMENT MARKINGS

DATE:	2021	REFERENCE	APPROVED
SCALE:	NTS		FIG No.:
			HRM 90

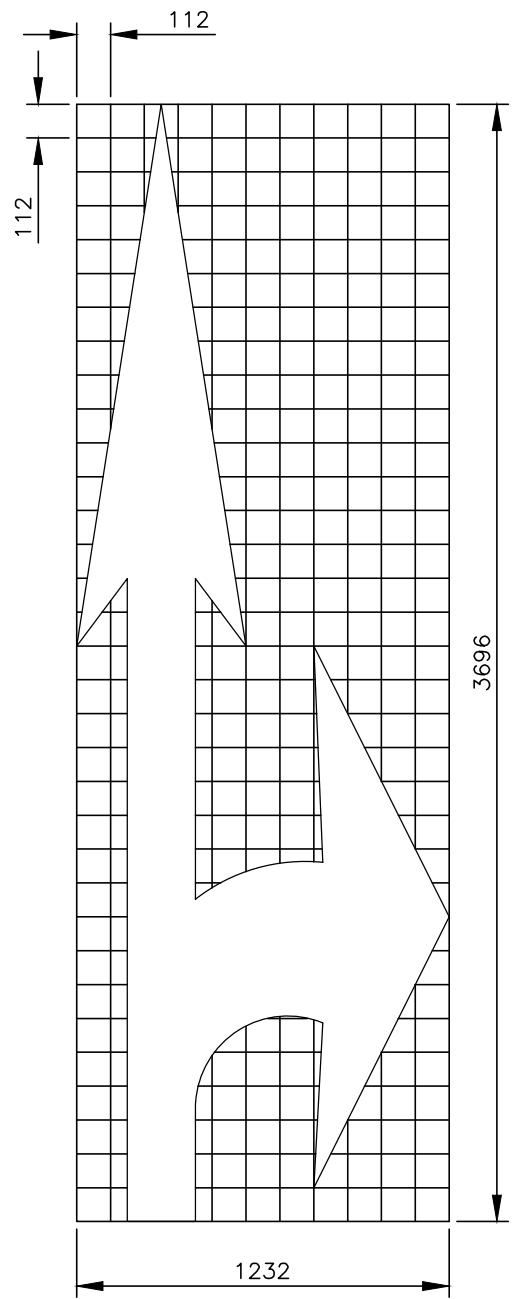
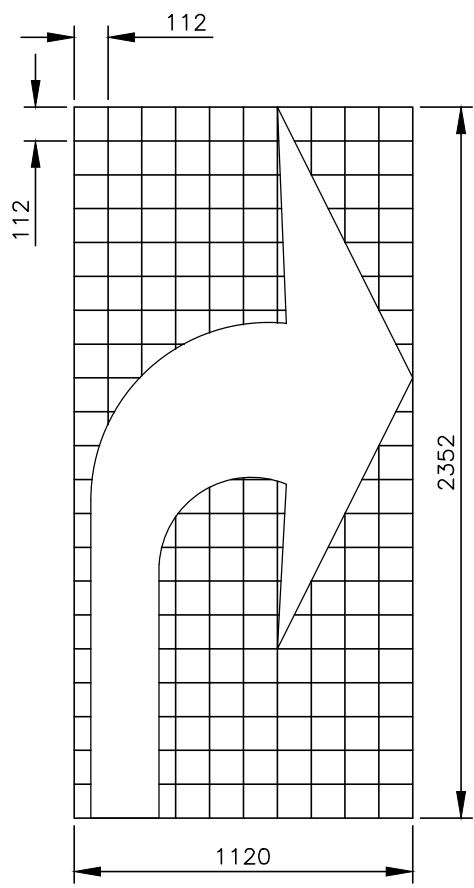
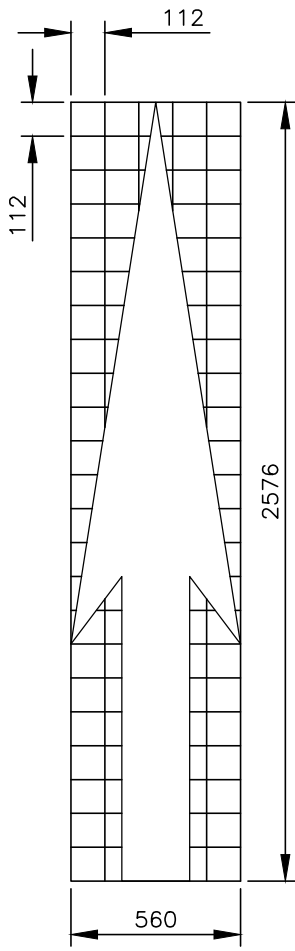

NOTE:
 1. DIMENSIONS ARE IN MILLIMETRES.

HALIFAX		
STANDARD DETAIL		
PAVEMENT ARROWS		
DATE:	2021	REFERENCE
SCALE:	1:25	APPROVED
		FIG No.:
		HRM 91

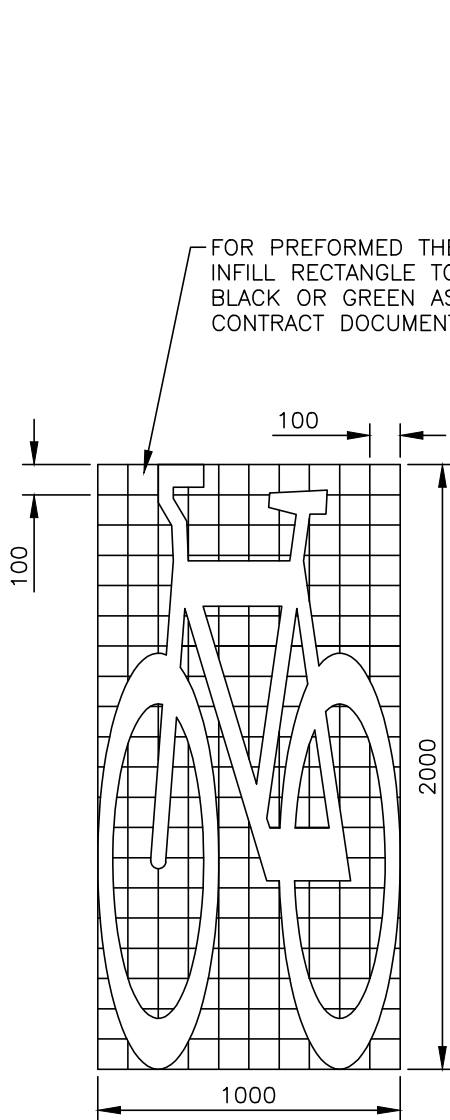

BICYCLE SYMBOL

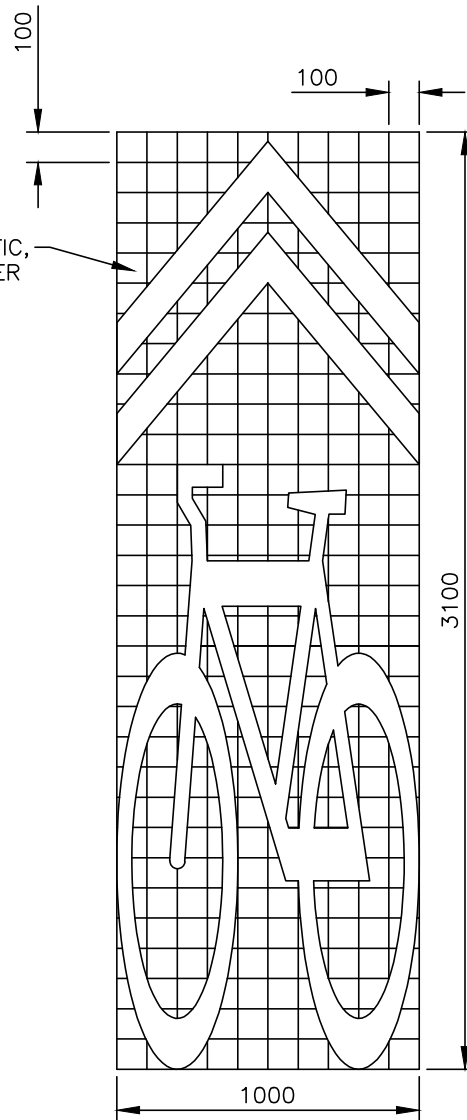

SHARED USE LANE SYMBOL

FOR PREFORMED THERMOPLASTIC,
INFILL RECTANGLE TO BE EITHER
BLACK OR GREEN AS PER
CONTRACT DOCUMENTS.

NOTE:

1. DIMENSIONS MAY BE SLIGHTLY ALTERED FOR THERMOPLASTIC IF APPROVED BY THE ENG.
2. DIMENSIONS ARE IN MILLIMETRES.

HALIFAX

STANDARD DETAIL

**BICYCLE SYMBOL &
SHARED USE LANE SYMBOL**

DATE:	2021	REFERENCE	APPROVED
SCALE:	1:25		FIG No.: HRM 92

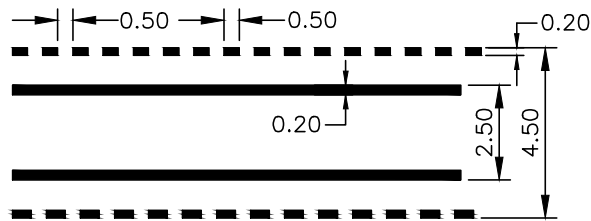
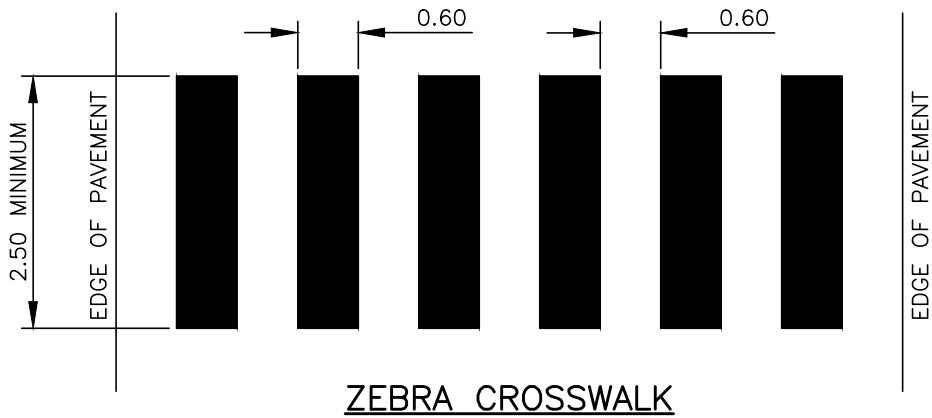
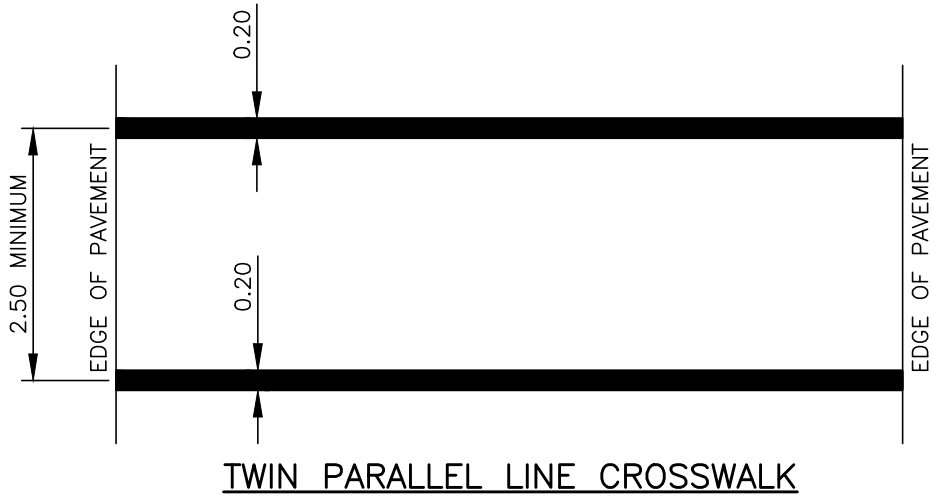

- 2.50 m WIDE CROSSWALK WITH 4.50 m WIDE TRAIL CROSSWALK

TRAIL CROSSING

NOTE:
1. DIMENSIONS ARE IN METRES.

HALIFAX		
STANDARD DETAIL		
PEDESTRIAN & TRAIL CROSSING PAVEMENT MARKINGS		
DATE:	REFERENCE	APPROVED
2021		
SCALE:		FIG No.:
NTS		HRM 93

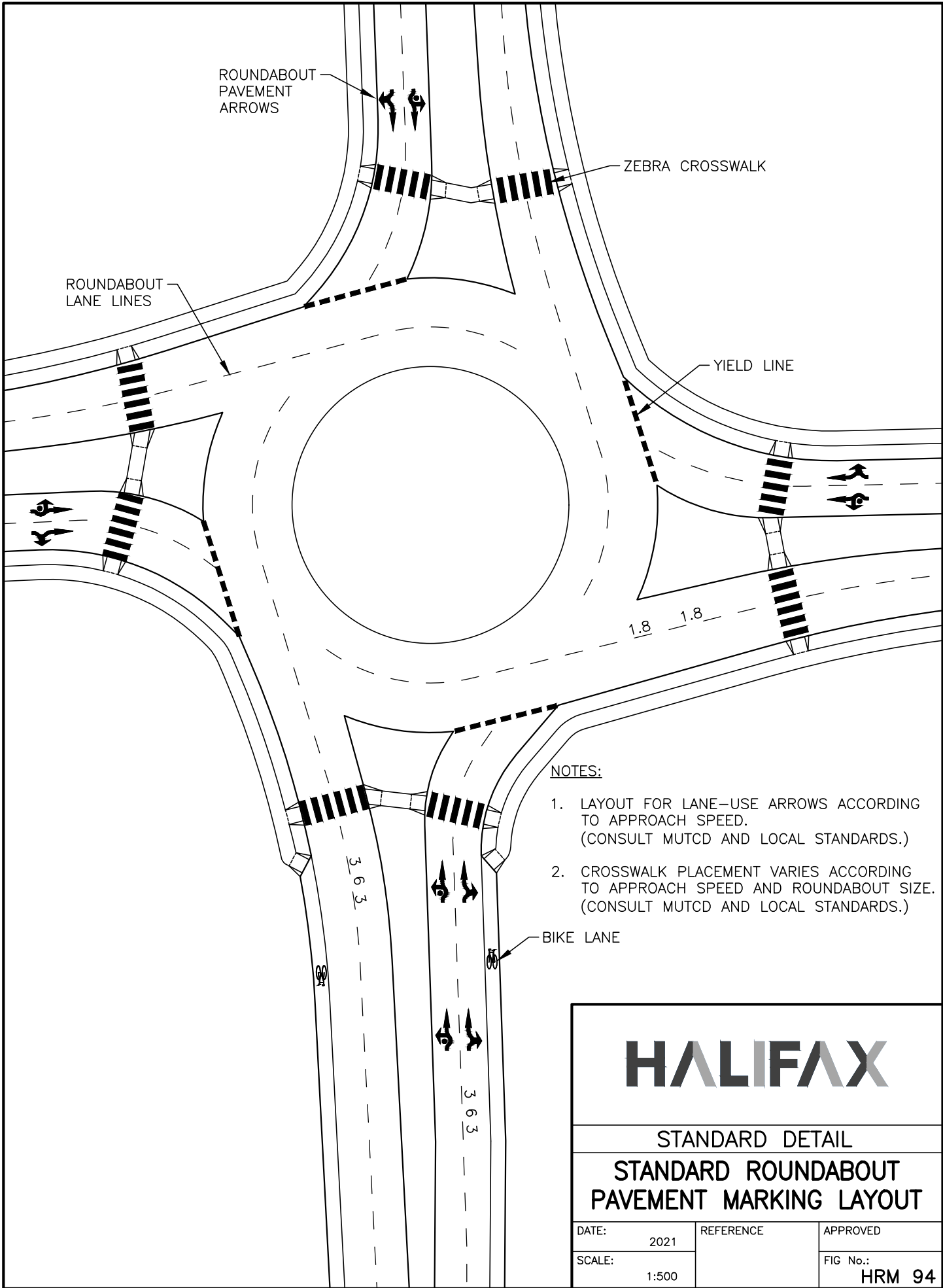

ROUNDABOUT
PAVEMENT
ARROWS

ZEBRA CROSSWALK

ROUNDABOUT
LANE LINES

YIELD LINE

1.8 1.8

3.6 3.6

3.6 3.6

NOTES:

1. LAYOUT FOR LANE-USE ARROWS ACCORDING TO APPROACH SPEED. (CONSULT MUTCD AND LOCAL STANDARDS.)
2. CROSSWALK PLACEMENT VARIES ACCORDING TO APPROACH SPEED AND ROUNDABOUT SIZE. (CONSULT MUTCD AND LOCAL STANDARDS.)

BIKE LANE

HALIFAX		
STANDARD DETAIL		
STANDARD ROUNDABOUT PAVEMENT MARKING LAYOUT		
DATE:	2021	REFERENCE
SCALE:	1:500	APPROVED
		FIG No.: HRM 94

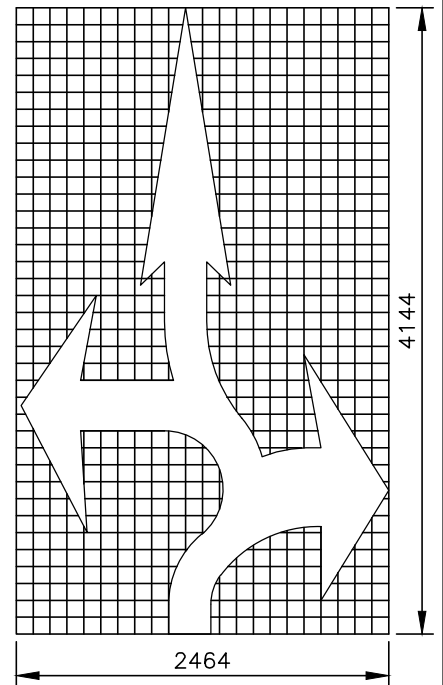
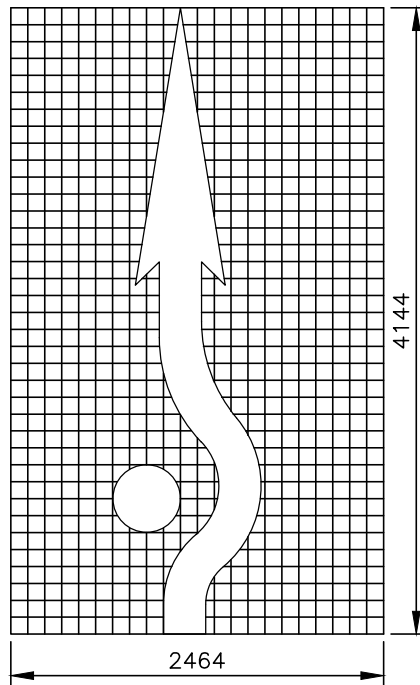
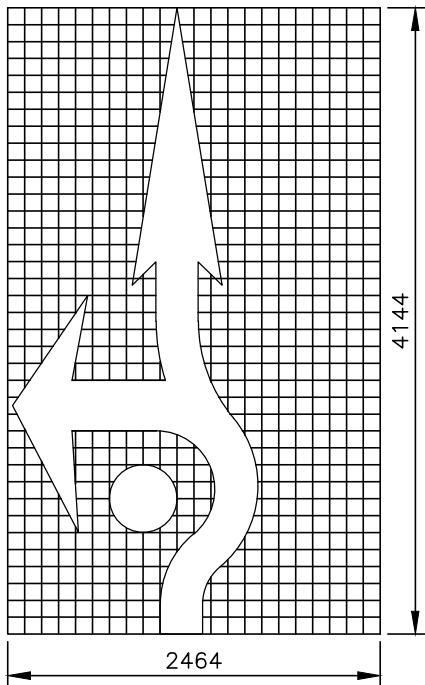
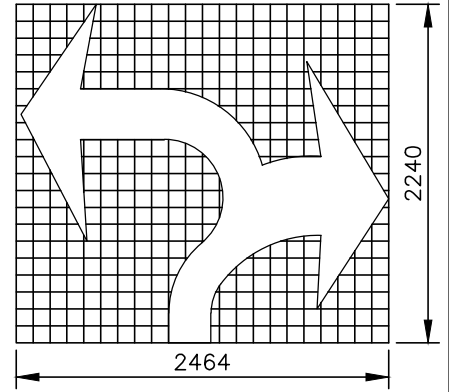
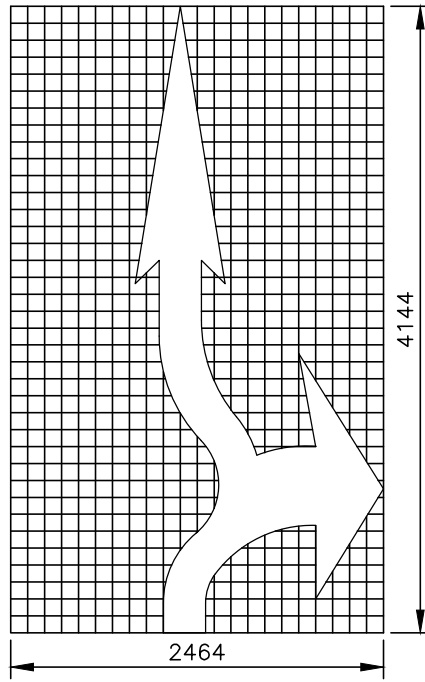
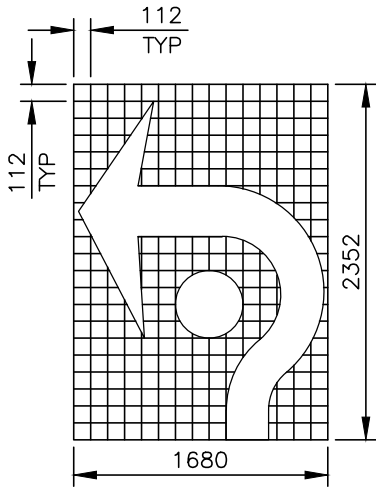

NOTES:
1. DIMENSIONS ARE IN MILLIMETRES.

HALIFAX

STANDARD DETAIL

ROUNDBOUT
PAVEMENT ARROWS

DATE:	2021	REFERENCE	APPROVED
SCALE:	1:50		FIG No.: HRM 95

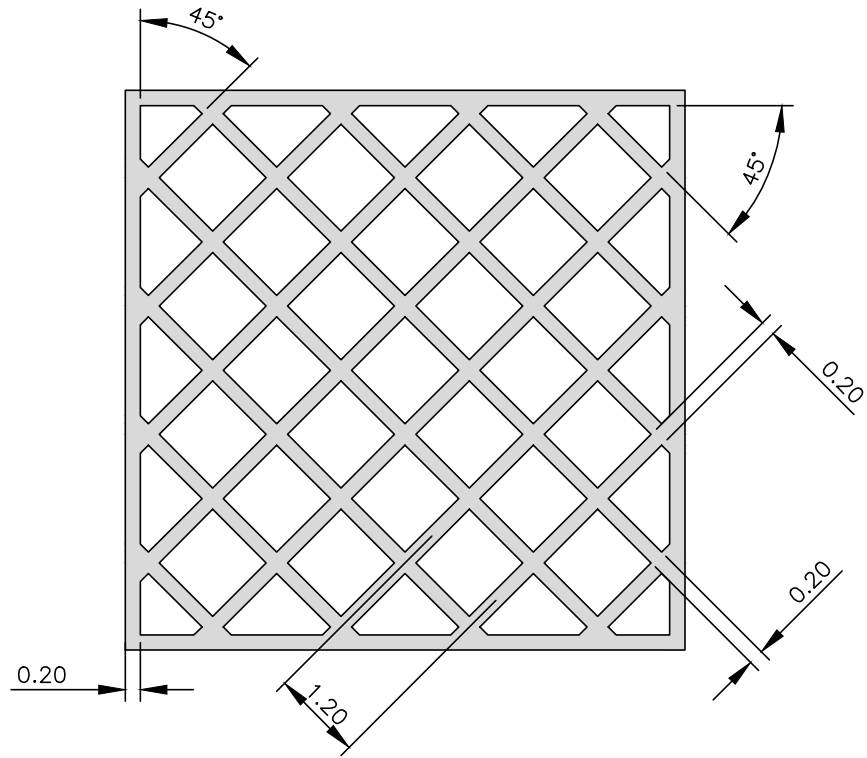

INTERSECTION BOX

SCALE: 1:100

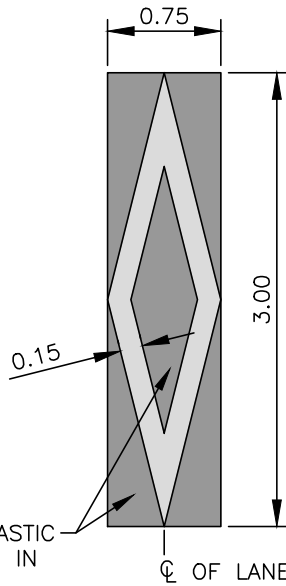

IF THERMOPLASTIC
THESE AREAS IN
BLACK

C OF LANE

RESERVED LANE

SCALE: 1:50

NOTE:

1. DIMENSIONS ARE IN METRES.

HALIFAX

STANDARD DETAIL

**SPECIAL
PAVEMENT MARKINGS**

DATE:	2021	REFERENCE	APPROVED
SCALE:	AS NOTED		FIG No.: HRM 96

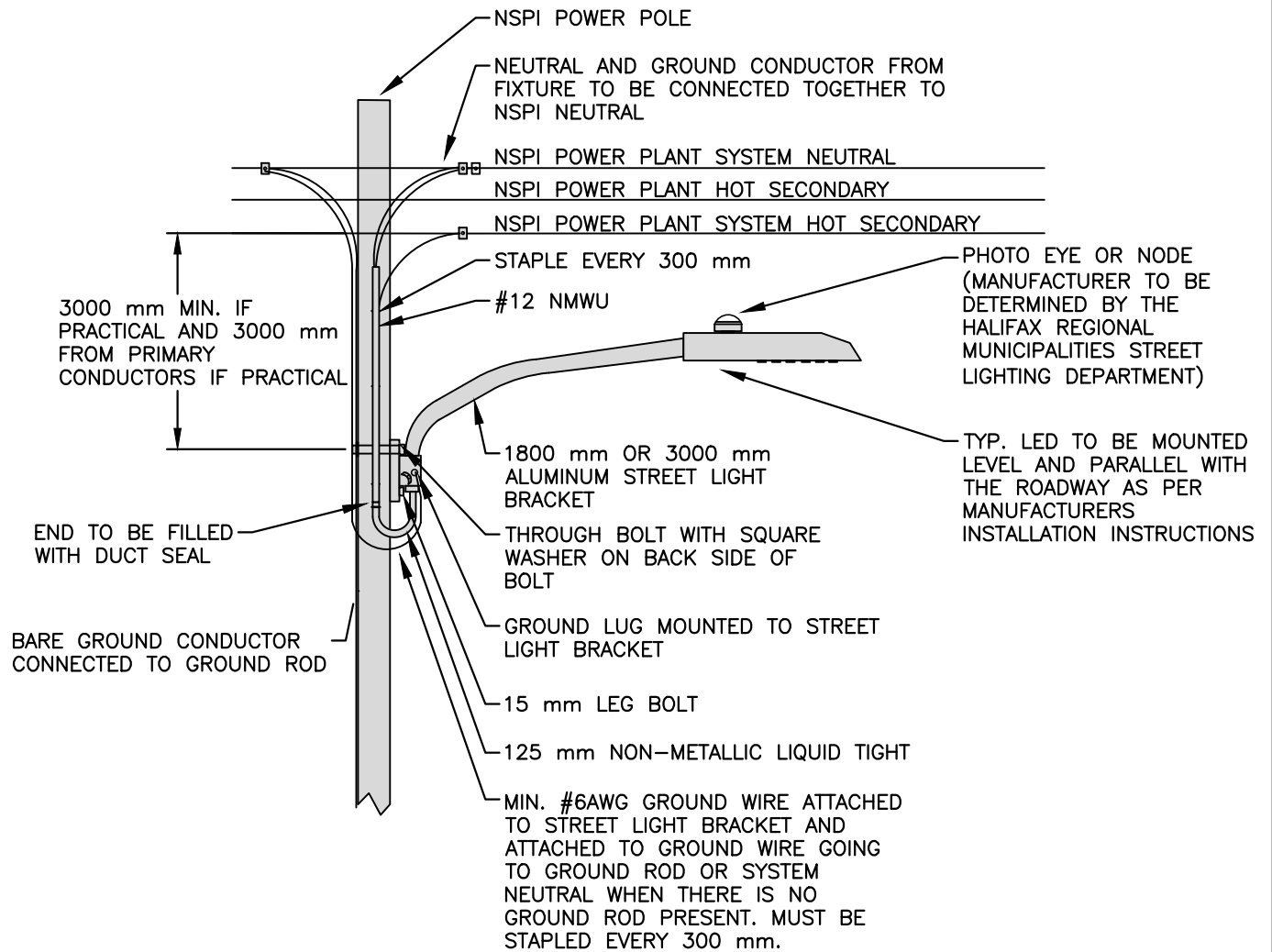

NOTES:

1. ALL WORK MUST BE IN COMPLIANCE WITH THE LATEST EDITION OF THE CANADIAN ELECTRICAL CODE.
2. ANY WORK DONE IN OR AROUND PRIMARY CONDUCTORS MUST BE PERFORMED BY A QUALIFIED PERSON AS PER HRM AND NSPI.
3. ANY FIXTURE BEING REPAIRED OR REPLACED MUST BE CONNECTED TO THE LINE IT IS TAKEN FROM.
4. ALL CONNECTIONS TO POWER NSPI POWER PLANT ARE TO BE MADE WITH TYCO KZ EP 4/0 PIERCING CONNECTORS.

HALIFAX

STANDARD DETAIL

TYPICAL COBRAHEAD-LED
ON A DAVIT ARM

DATE:	2021	REFERENCE	APPROVED
SCALE:	NTS		FIG No.: HRM 97

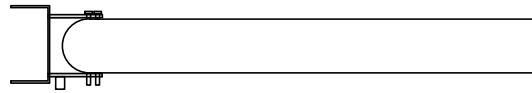

TOP VIEW

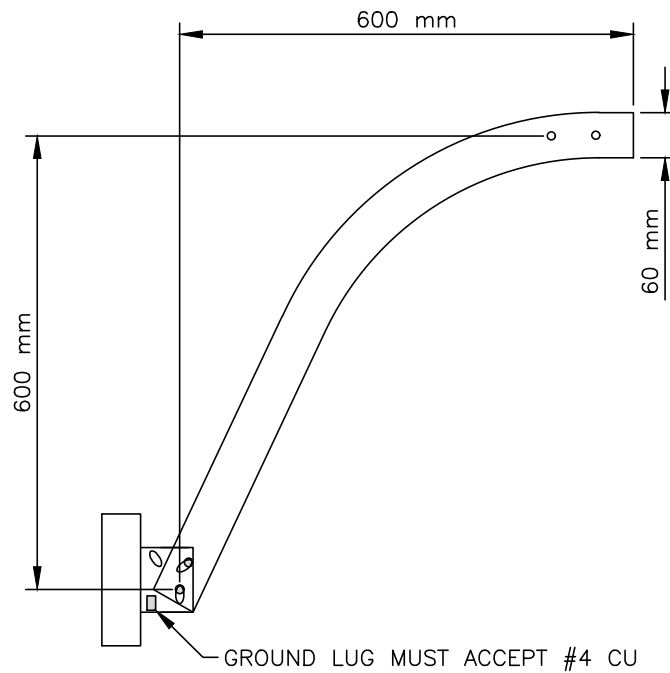

SIDE VIEW

MANUFACTURER: LUMINEX
CAT #: P-197

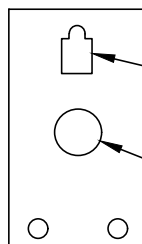

MUST ACCEPT 16 mm
SQUARE HEAD THROUGH BOLT

MINIMUM 25 mm WIRE ENTRY HOLE

BRACKET

HALIFAX

STANDARD DETAIL

DAVIT ARM - 600 mm

DATE:	2021	REFERENCE	APPROVED
SCALE:	NTS		FIG No.: HRM 98

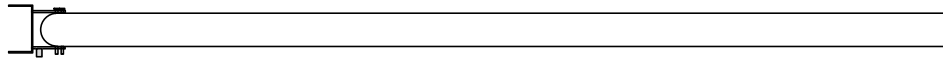

TOP VIEW

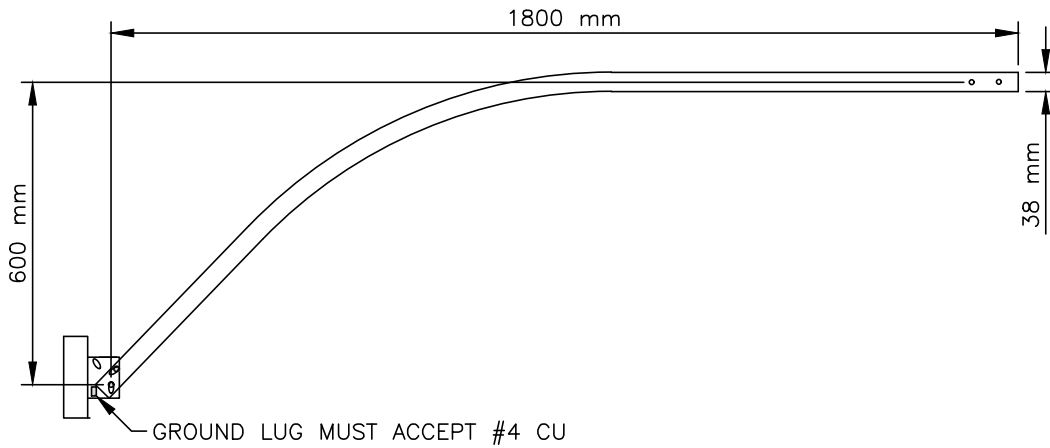

SIDE VIEW

MANUFACTURER: ALL-STRUCT
CAT # WPB 72X24

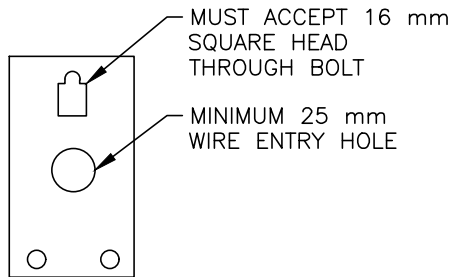

BRACKET

HALIFAX

STANDARD DETAIL

DAVIT ARM – 1800 mm

DATE:	2021	REFERENCE	APPROVED
SCALE:	NTS		FIG No.: HRM 99

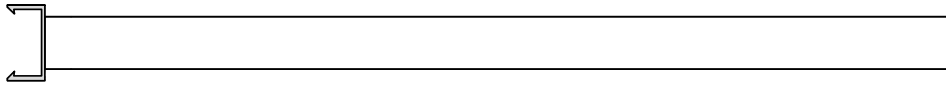

TOP VIEW

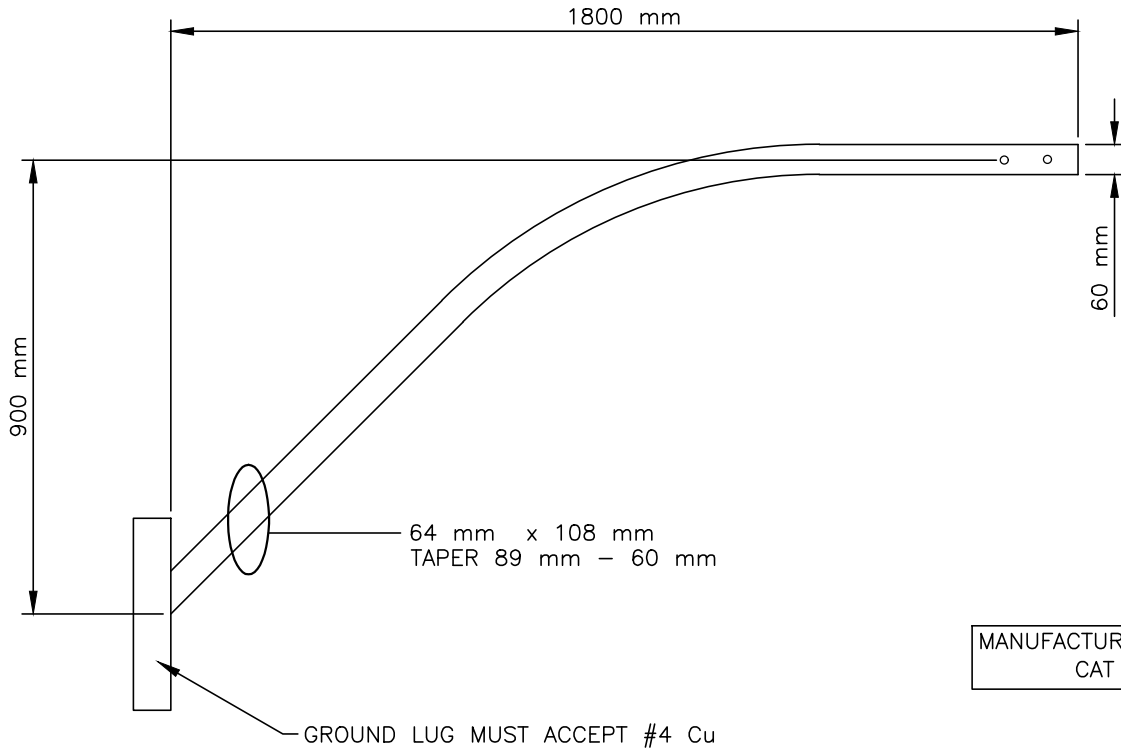

MANUFACTURER: ALL-STRUCT
CAT #REGMA

SIDE VIEW

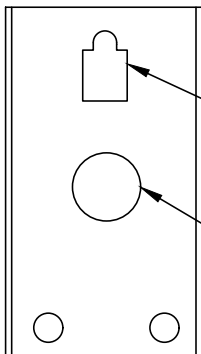

BRACKET

MUST ACCEPT 16 mm
SQUARE HEAD THROUGH
BOLT

MINIMUM 25 mm
WIRE ENTRY HOLE

HALIFAX

STANDARD DETAIL

**ELLIPTICAL
DAVIT ARM - 1800 mm**

DATE:	2021	REFERENCE	APPROVED
SCALE:	NTS		FIG No.: HRM 100

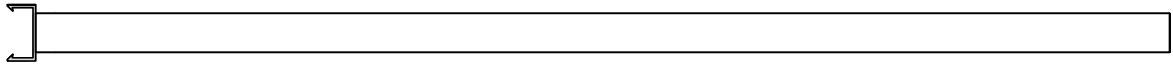

TOP VIEW

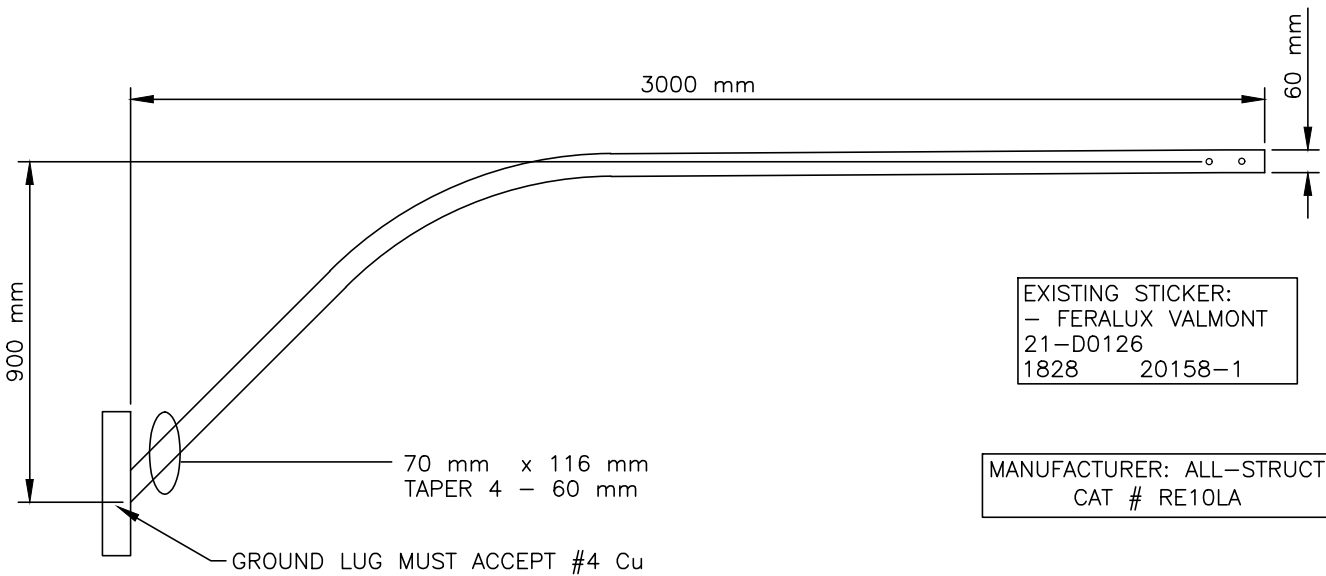

SIDE VIEW

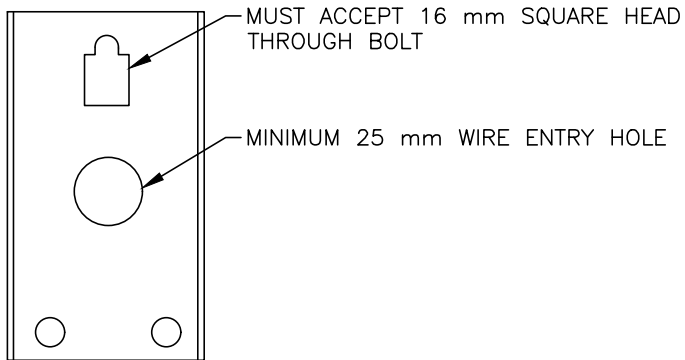

BRACKET

HALIFAX

STANDARD DETAIL

ELLIPTICAL
DAVIT ARM - 3000 mm

DATE:	2021	REFERENCE	APPROVED
SCALE:	NTS		FIG No.: HRM 101

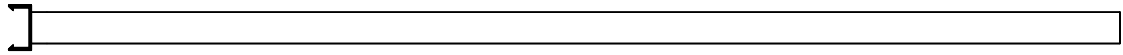

TOP VIEW

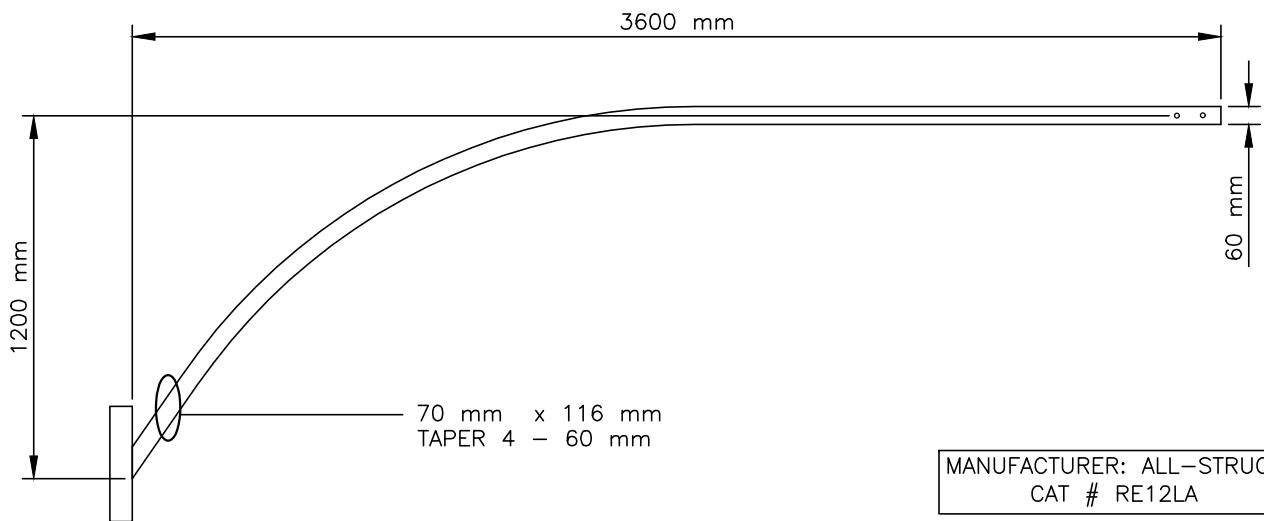

SIDE VIEW

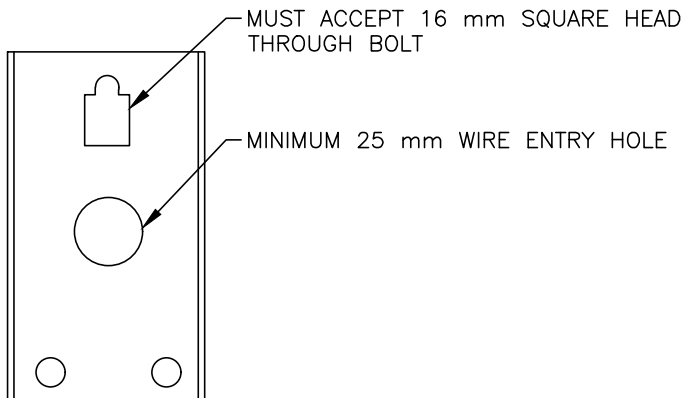

BRACKET

HALIFAX

STANDARD DETAIL

ELLIPTICAL
DAVIT ARM - 3600 mm

DATE: 2021	REFERENCE	APPROVED
SCALE: NTS		FIG No.: HRM 102

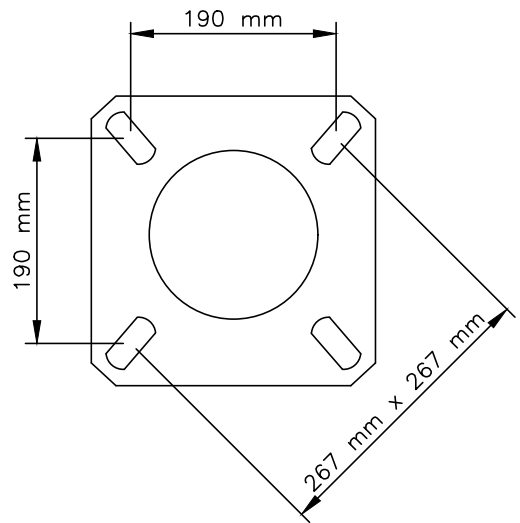
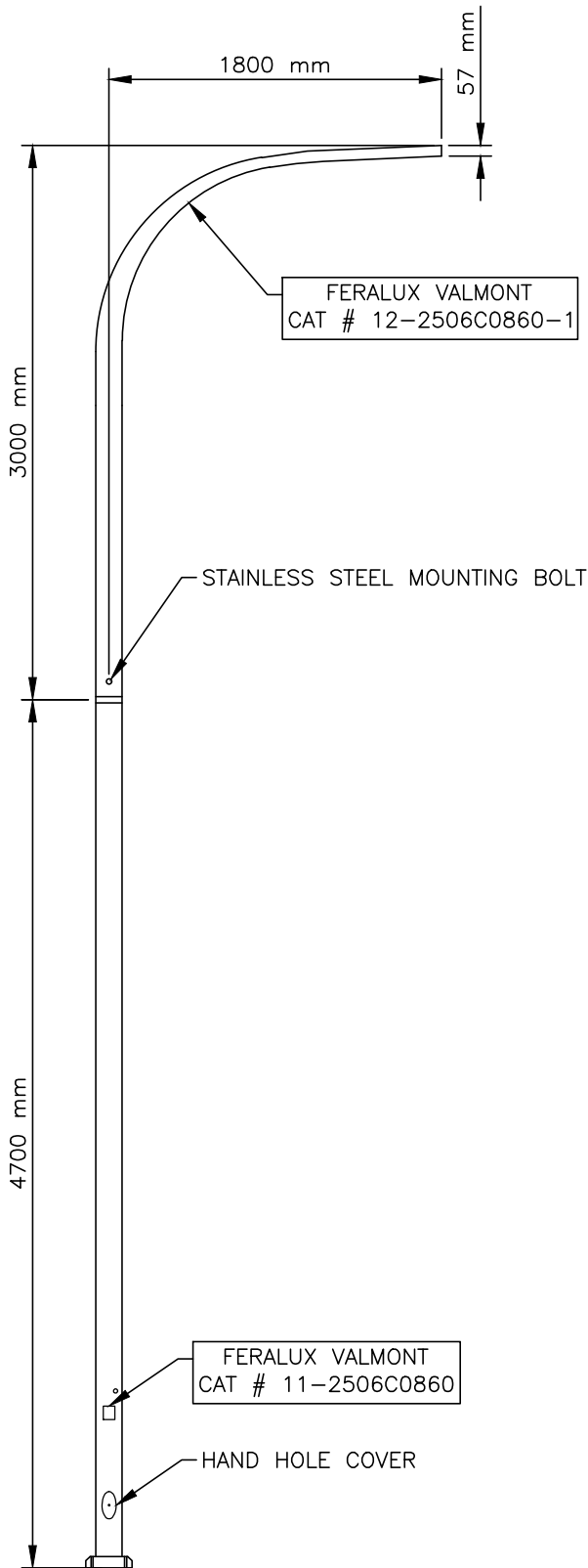

BOLT PATTERN
BOTTOM VIEW

NOTES:

1. WALL THICKNESS 0.188 mm
2. MUST HAVE A HAND HOLE COVER
3. MUST HAVE TWO STAINLESS STEEL MOUNTING BOLTS FOR DAVIT TO POLE CONNECTION.

HALIFAX

STANDARD DETAIL

**ALUMINIUM
LIGHTING STANDARD-7.7 m**

DATE:	2021	REFERENCE	APPROVED
SCALE:	NTS		FIG No.: HRM 103

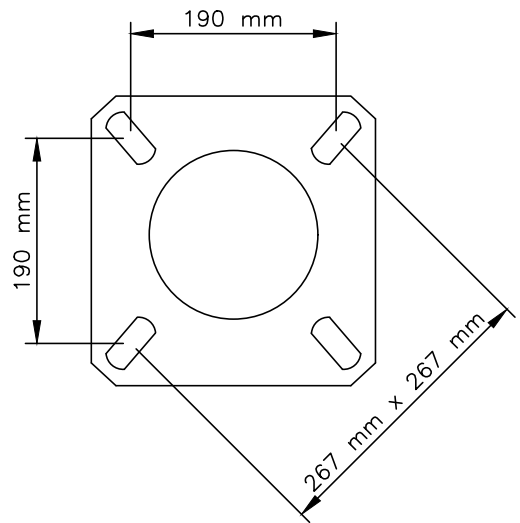
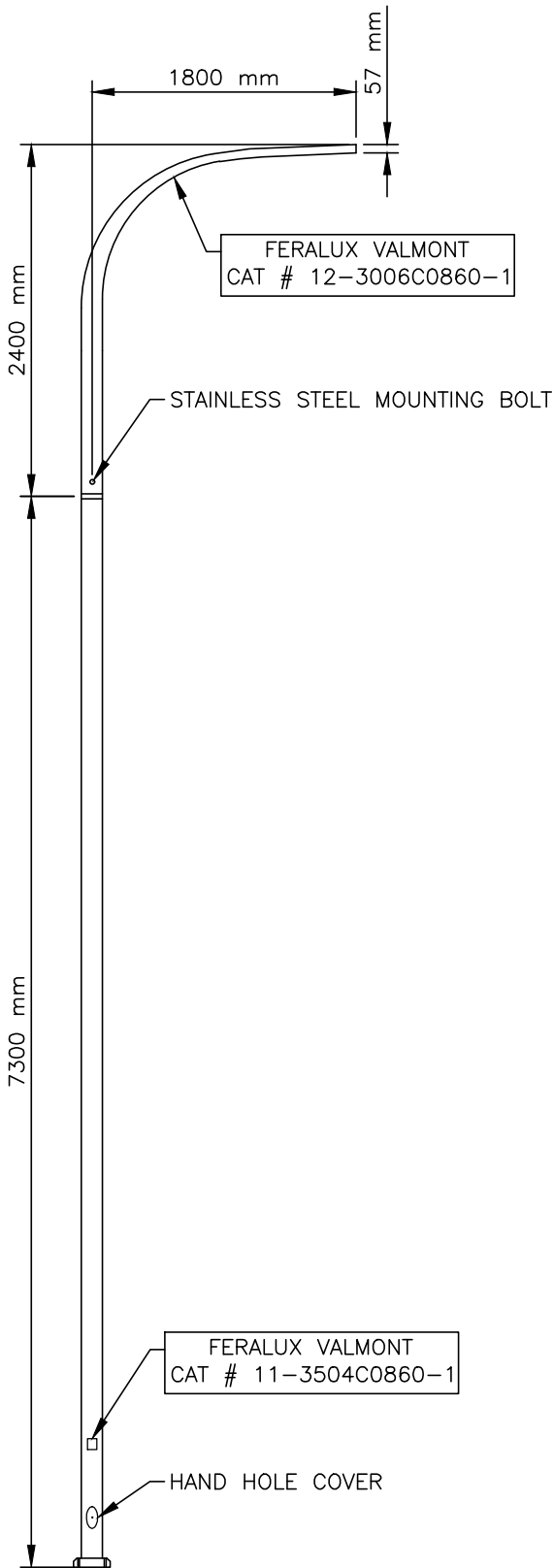

BOLT PATTERN
BOTTOM VIEW

NOTES:

1. WALL THICKNESS 0.188 mm
2. MUST HAVE A HAND HOLE COVER
3. MUST HAVE TWO STAINLESS STEEL MOUNTING BOLTS FOR DAVIT TO POLE CONNECTION.

HALIFAX

STANDARD DETAIL

**ALUMINIUM
LIGHTING STANDARD-9.7 m**

DATE:	2021	REFERENCE	APPROVED
SCALE:	NTS		FIG No.: HRM 104

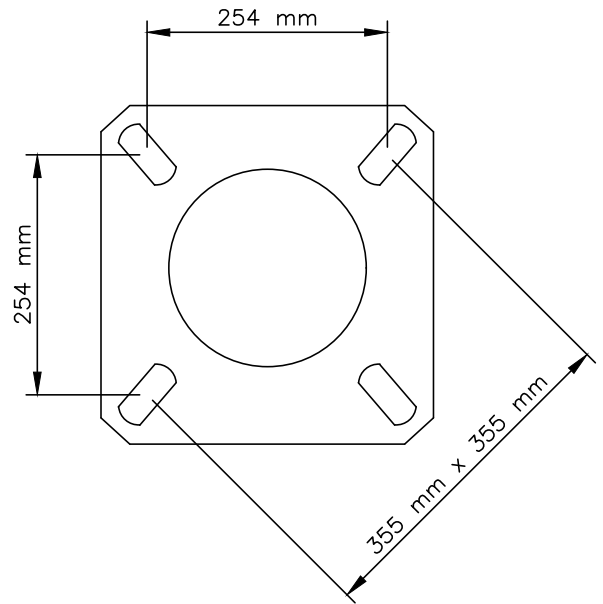
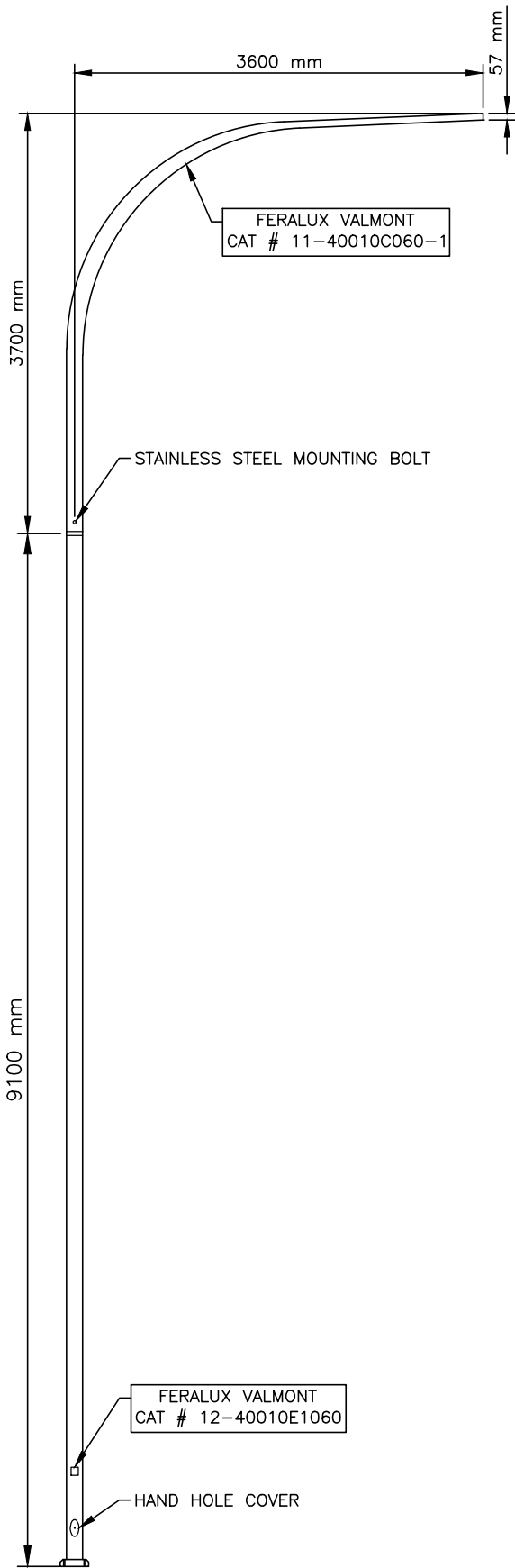

BOLT PATTERN
BOTTOM VIEW

NOTES:

1. WALL THICKNESS 0.188 mm
2. MUST HAVE A HAND HOLE COVER
3. MUST HAVE TWO STAINLESS STEEL MOUNTING BOLTS FOR DAVIT TO POLE CONNECTION.

HALIFAX

STANDARD DETAIL

**ALUMINIUM LIGHTING
STANDARD-12.2 m**

DATE:	2021	REFERENCE	APPROVED
SCALE:	NTS		FIG No.: HRM 105

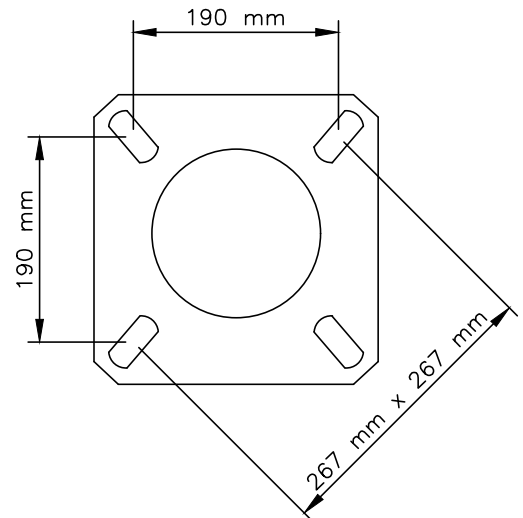
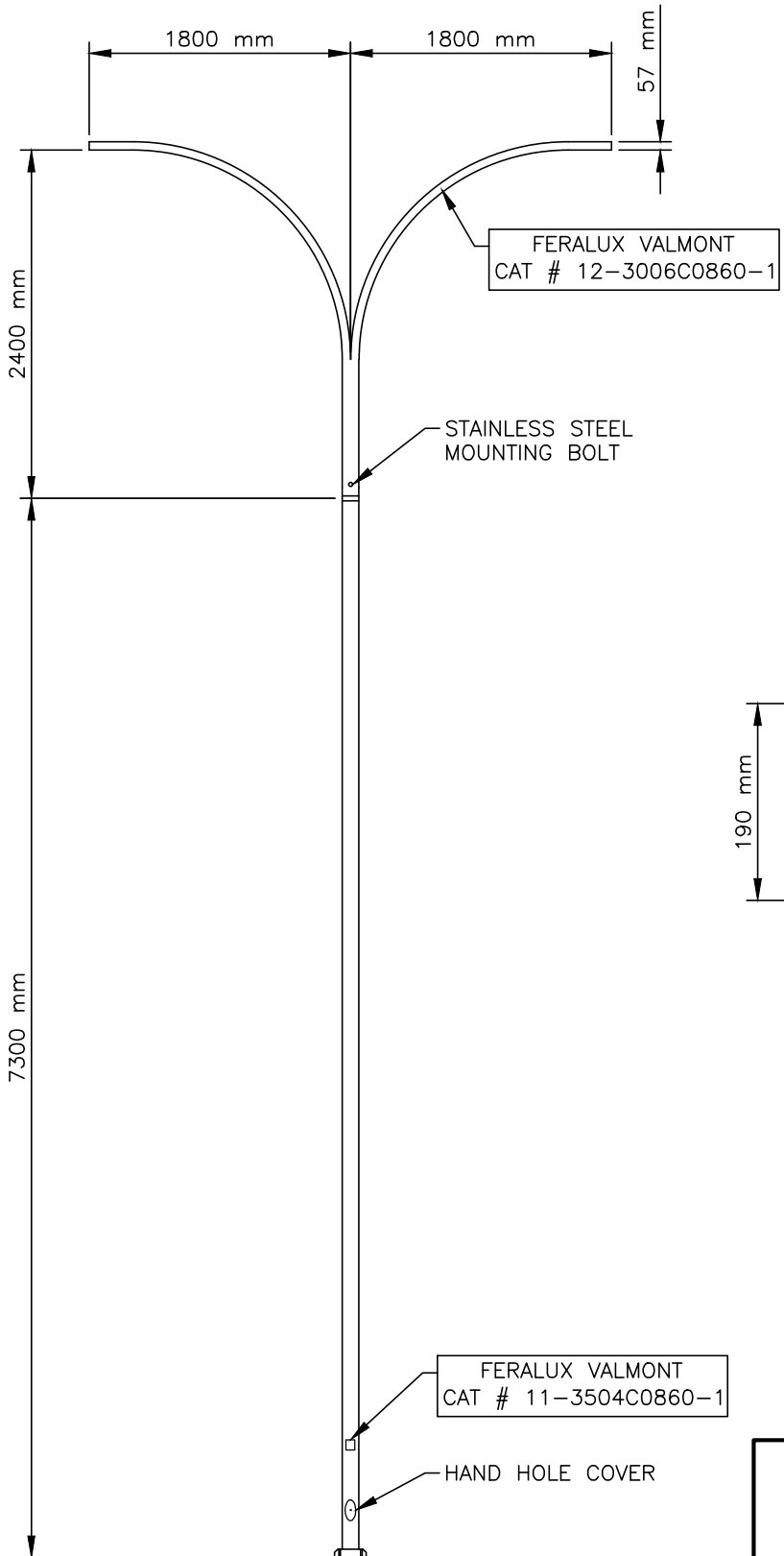

BOLT PATTERN
BOTTOM VIEW

**TYPICAL DOUBLE DAVIT
ALUMINIUM LIGHTING STANDARD**

NOTES:

1. WALL THICKNESS 0.188 mm
2. MUST HAVE A HAND HOLE COVER
3. MUST HAVE TWO STAINLESS STEEL MOUNTING BOLTS FOR DAVIT TO POLE CONNECTION.

<h1>HALIFAX</h1>		
STANDARD DETAIL		
ALUMINIUM DOUBLE DAVIT LIGHTING STANDARD- 9.7m		
DATE: 2021	REFERENCE	APPROVED
SCALE: NTS		FIG No.: HRM 106

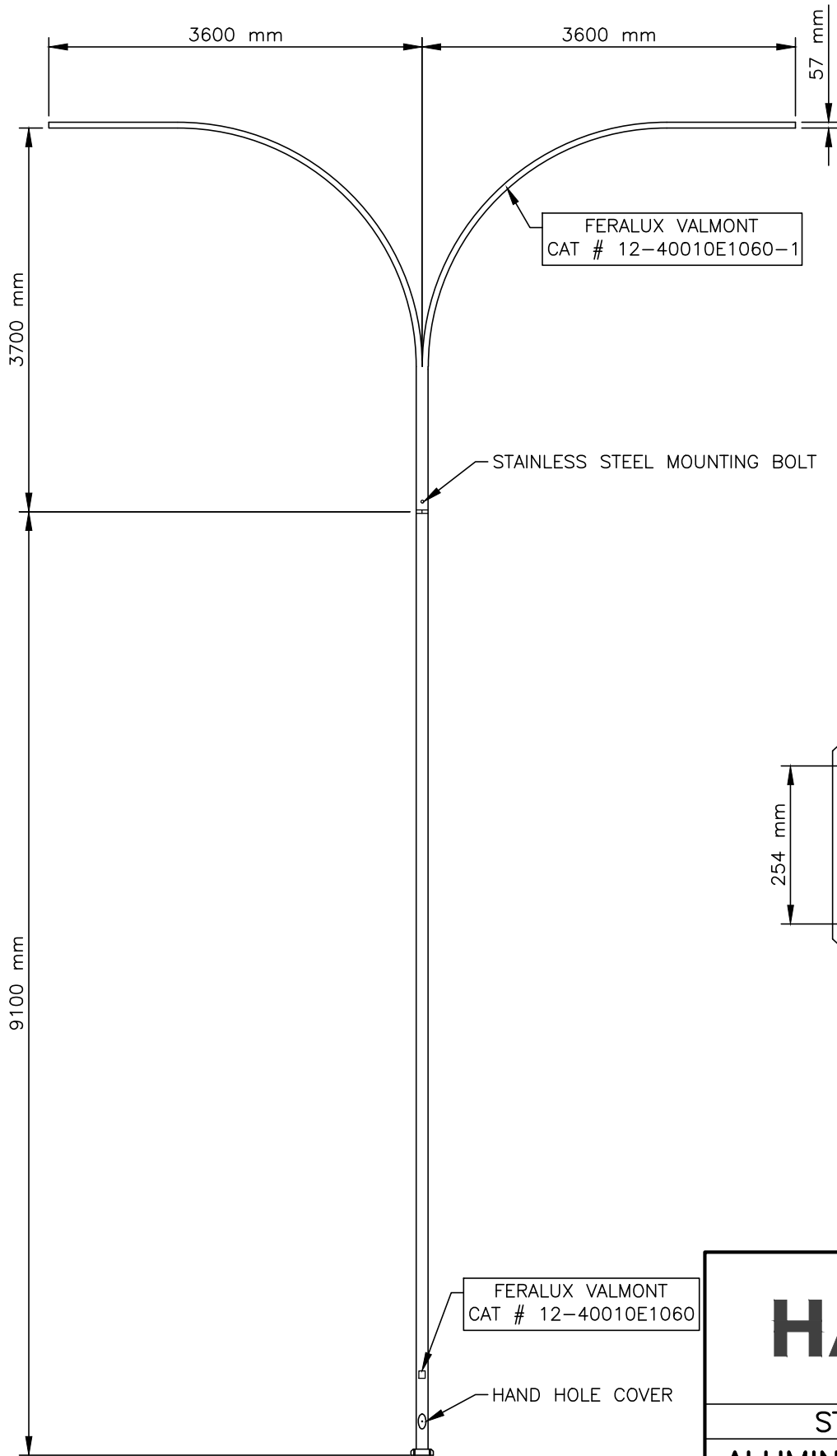

NOTES:

1. WALL THICKNESS 0.188 mm
2. MUST HAVE A HAND HOLE COVER
3. MUST HAVE TWO STAINLESS STEEL MOUNTING BOLTS FOR DAVIT TO POLE CONNECTION.

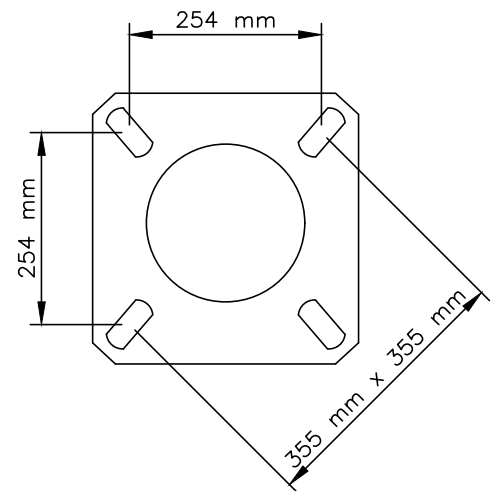

BOLT PATTERN
BOTTOM VIEW

TYPICAL DOUBLE DAVIT
ALUMINIUM LIGHTING STANDARD

HALIFAX

STANDARD DETAIL

ALUMINIUM DOUBLE DAVIT
LIGHTING STANDARD-12.2m

DATE:	2021	REFERENCE	APPROVED
SCALE:	NTS		FIG No.: HRM 107

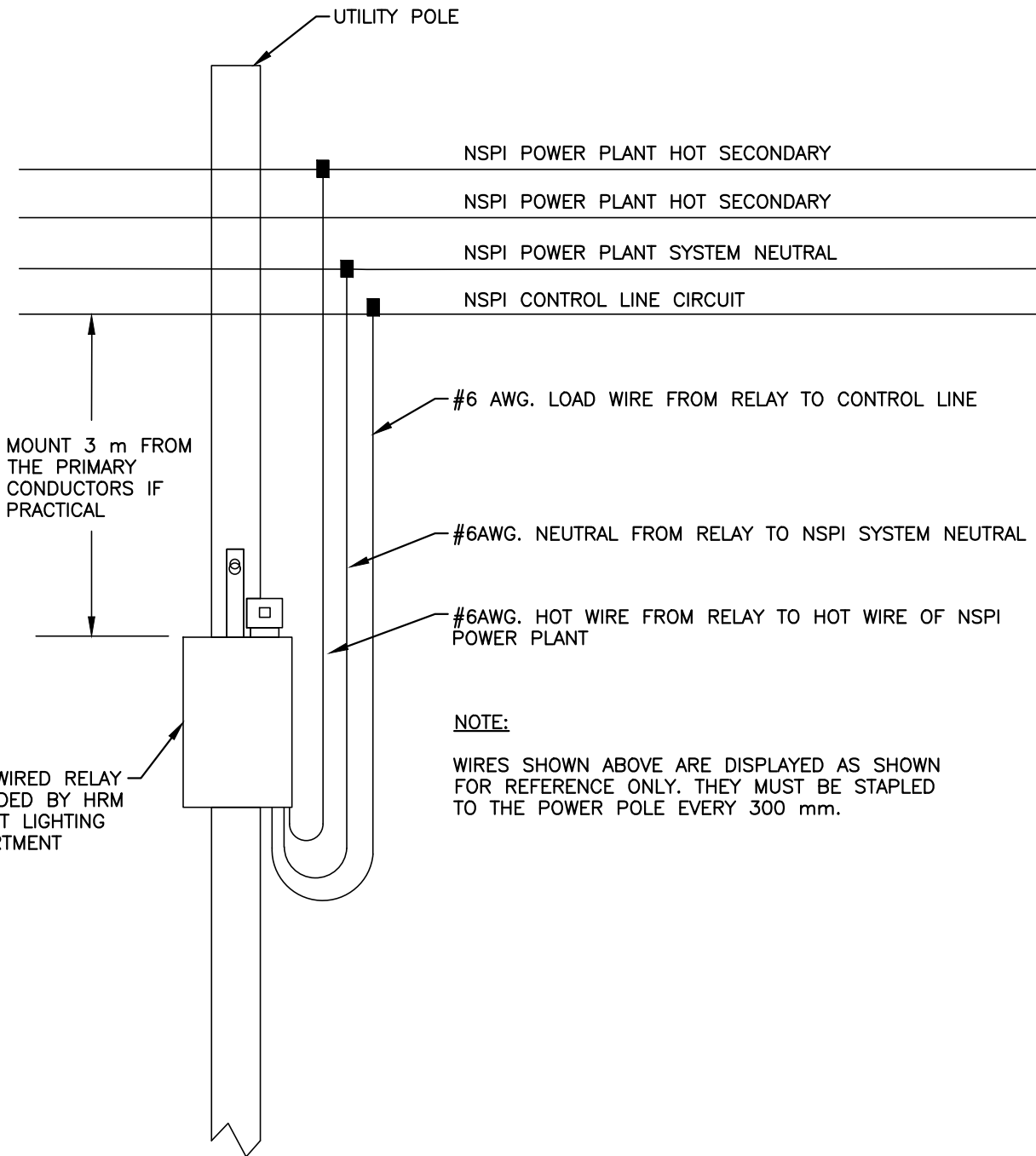

NOTES:

1. ALL WORK MUST BE IN COMPLIANCE WITH THE LATEST EDITION OF THE CANADIAN ELECTRICAL CODE.
2. ANY WORK DONE IN OR AROUND PRIMARY CONDUCTORS MUST BE PERFORMED BY A QUALIFIED PERSON.
3. WHEN MOUNTING THE RELAY POSITION THE PHOTOEYE AWAY FROM THE NEAREST LIGHT FIXTURE.
4. ALL CONNECTIONS TO POWER NSPI POWER PLANT ARE TO BE MADE WITH TYCO KZ EP 4/0 PIERCING

HALIFAX

STANDARD DETAIL

RELAY INSTALLATION

DATE:	2021	REFERENCE	APPROVED
SCALE:	NTS		FIG No.: HRM 108

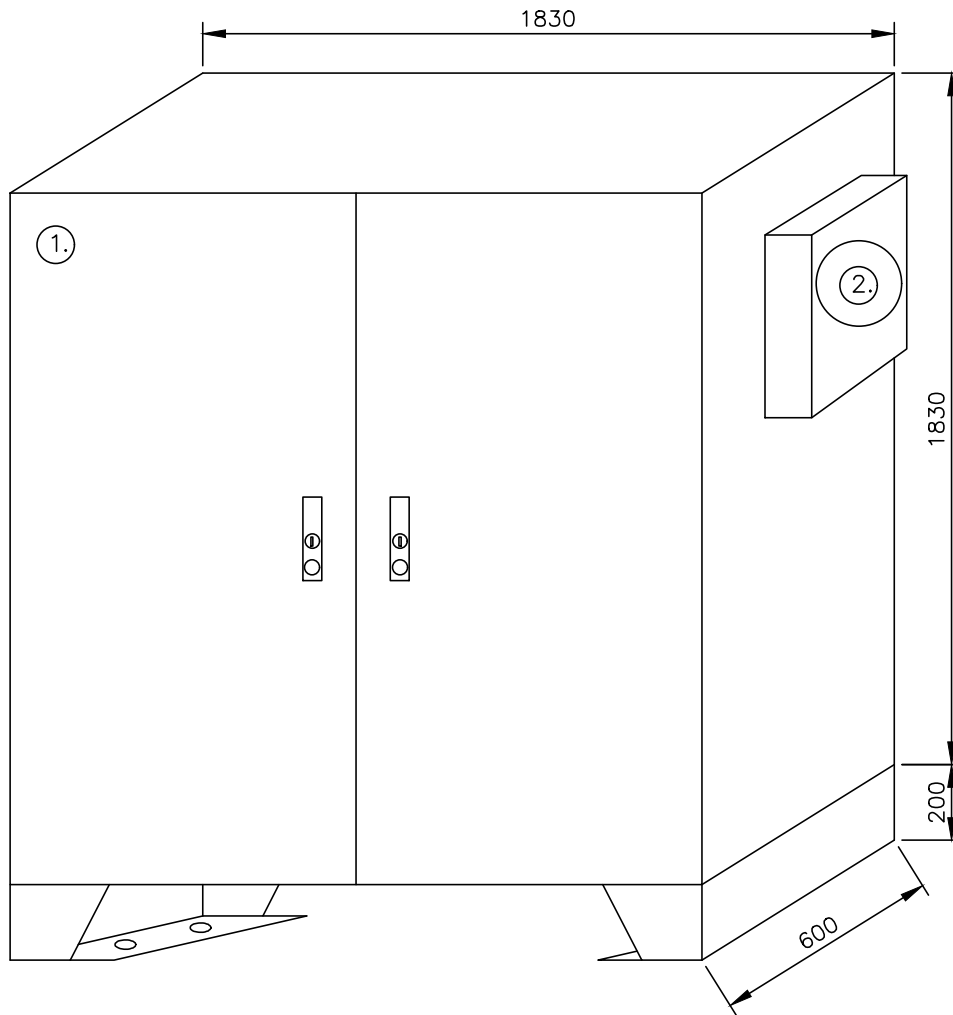

PART NUMBERING AND DESCRIPTIONS:

1. BEL PART NUMBER #HDM727224FSS-M 1830x1830 C/W 200mm AND BACKPLATE.
2. STREET LIGHTING POWER METER BASE PART#PL17-TCV-IN.

NOTES:

1. ALL WIRING MUST BE DONE IN ACCORDANCE WITH THE LATEST EDITION OF THE CANADIAN ELECTRICAL CODE.
2. CABINET MUST BE CSA APPROVED.
3. CABINET DOORS MUST HAVE BARS TO HOLD DOORS OPEN.
4. CABINET DOORS MUST BE LOCKABLE AND BE ABLE TO ACCEPT A PADLOCK.
5. CABINET MUST HAVE A REMOVABLE CENTRE POST FOR THE DOORS.
6. ALL MOUNTING SCREWS MUST BE STAINLESS.
7. CABINET MUST HAVE A DRAWING HOLDER AND ALL WIRING SCHEMATICS.
8. MANUFACTURER MUST PROVIDE REPLACEMENT FUSES, LIGHTBULB, AND A SPARE COIL. TO BE MOUNTED IN A PVC JUNCTION BOX IN A CONVENIENT LOCATION.
9. ALL COMPONENTS MUST BE LABELLED WITH LAMACOIDS IE; VOLTAGE, CURRENT, AND CIRCUIT.
10. ITEM #7 MUST BE LABELLED WITH LAMACOIDS TO INDICATE WHAT THE CIRCUIT IS FEEDING.
11. DIMENSIONS ARE IN MILLIMETRES.

HALIFAX

STANDARD DETAIL

**STREET LIGHT
POWER ENCLOSURE**

DATE:	2021	REFERENCE	APPROVED
SCALE:	NTS		FIG No.: HRM 109

FROM NSPI POWER PLANT

100AMP 600 VOLT 3P NF
DISCONNECT ITEM #13

200AMP 3P 600VOLT
METER ITEM #2

PHOTOEYE
ITEM #14

TO GROUND
PLATE

10AMP 2 POLE BREAKER
ITEM #5

600V TO 240V
1P 1.5KVA
XFMR Item #6

100AMP 3P 600VOLT 4WIRE
3FOOT SPLITTER ITEM #4

LIGHT
ITEM #8

H1 600Volts H2
X1 X2 X3 X4
240 Volts

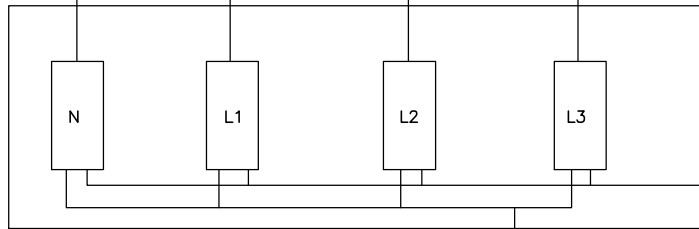

LIGHTING PANEL
ITEM #16

100AMP 600 VOLT 3P
BREAKER ITEM #12

SINGLE POLE
SWITCH
ITEM #9

4CCT PANEL
EQL4100
ITEM #7

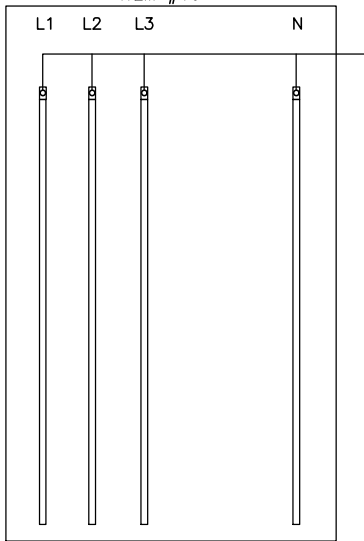

100AMP 3P 600 VOLT
LIGHTING CONTACTOR
ITEM #13

800Watt
HEATER
ITEM#11

20Amp
GFCI
ITEM #10

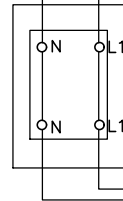
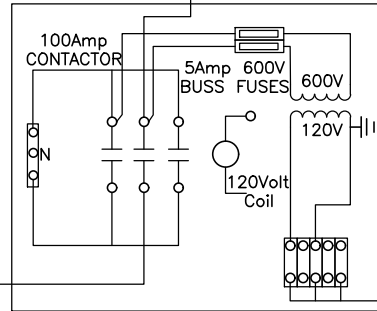

HALIFAX

STANDARD DETAIL

STREET LIGHT POWER ENCLOSURE DIAGRAM

DATE:	2021	REFERENCE	APPROVED
SCALE:	NTS		FIG No.: HRM 110

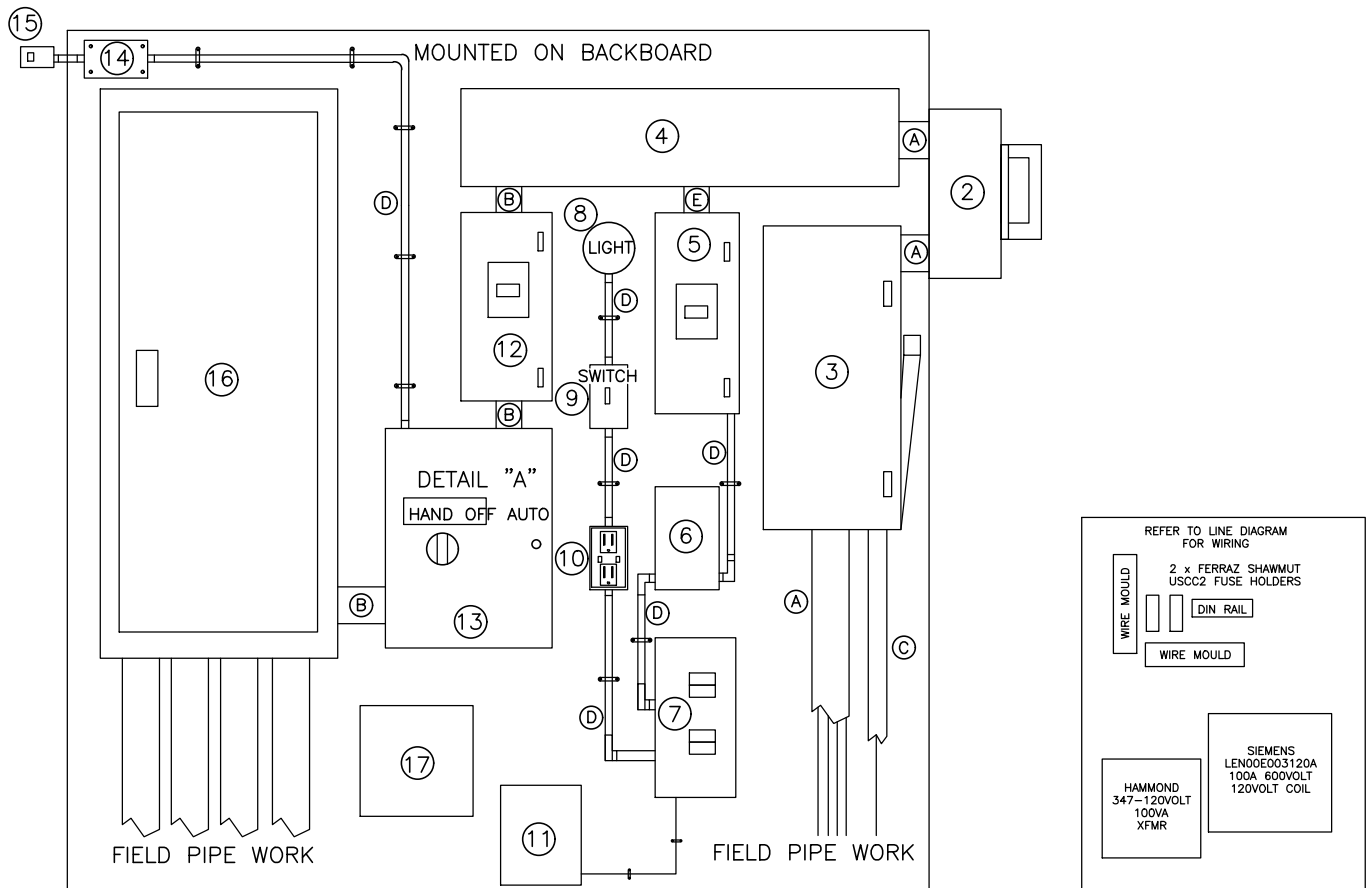

DETAIL "A"

PART NUMBERING AND DESCRIPTIONS:

1. BEL PART NUMBER #HDM727224FSS-M 1830x1830 C/W 200 mm AND BACKPLATE.
2. STREET LIGHTING POWER METER BASE PART#PL17-TCV-IN.
3. 100AMP 3P 600VOLT NON-FUSEABLE SIEMENS ID363NF.
4. BEL 200AMP 3P 600VOLT SPLITTER PART#T3204.
5. 20AMP 2P 600VOLT BREAKER SIEMENS PART#ED63B020L C/W E2NIS ENCLOSURE.
6. 1.5KVA XFMR HAMMOND PART#Q1C5PEKF.
7. 4 X 15AMP 1P BREAKER SIEMENS PART#Q115 C/W EQL4100 ENCLOSURE.
8. RAB DEMVCS100CG LIGHT C/W DEMGD100CGS CAGE C/W CFL LIGHTBULB.
9. RAB DEVICE BOX IBCS100CN C/W WEATHERPROOF PVC COVER AND COMMERCIAL GRADE SINGLE POLE SWITCH LEVCS1152W.
10. RAB DEVICE BOX IBCS100CN C/W WEATHERPROOF PVC COVER AND 20AMP T SLOT GFCI LEV7899W.
11. 800WATT HEATER CALORITECH PART#PH80011.
12. 100AMP 3P 600VOLT BREAKER SIEMENS PART#ED63B100L C/W E2NIS ENCLOSURE.
13. 100AMP LEN CONTACTOR C/W HOA IN 406 mm x 406 mm x 203 mm ENCLOSURE(REFER TO DETAIL A).
14. RAB DEVICE BOX IBCS100CN C/W BLANK PVC WEATHERPROOF COVER SCEBRC1510.
15. INTERMATIC PHOTOCCELL PART#K4221C.
16. SIEMENS DISTRIBUTION PANEL PART#P1L42ML125CBS 3P 4 WIRE 600VOLT 42 CRT.
17. PVC JUNCTION BOX CAPABLE OF HOLDING EXTRA FUSES AND AN EXTRA COIL.

CONDUIT AND WIRE SIZING:

- A. 53 mm CONDUIT C/W 4 x #3 RWU90 & 1 x #8 GRN CONDUCTORS.
- B. 41 mm CONDUIT C/W 4 x #3 RWU90 & 1 x #8 GRN CONDUCTORS.
- C. 25 mm CONDUIT C/W 1 x #6 GRN.
- D. 12.5 mm NMFC OR 12.5 mm PVC C/W 2 x #12 RWU90 & #12 GRN.
- E. 25 mm CONDUIT C/W 2 x #10 RWU90 & #8 GRN.

HALIFAX

STANDARD DETAIL

**STREET LIGHT
POWER ENCLOSURE LAYOUT**

DATE:	2021	REFERENCE	APPROVED
SCALE:	NTS		FIG No.: HRM 111

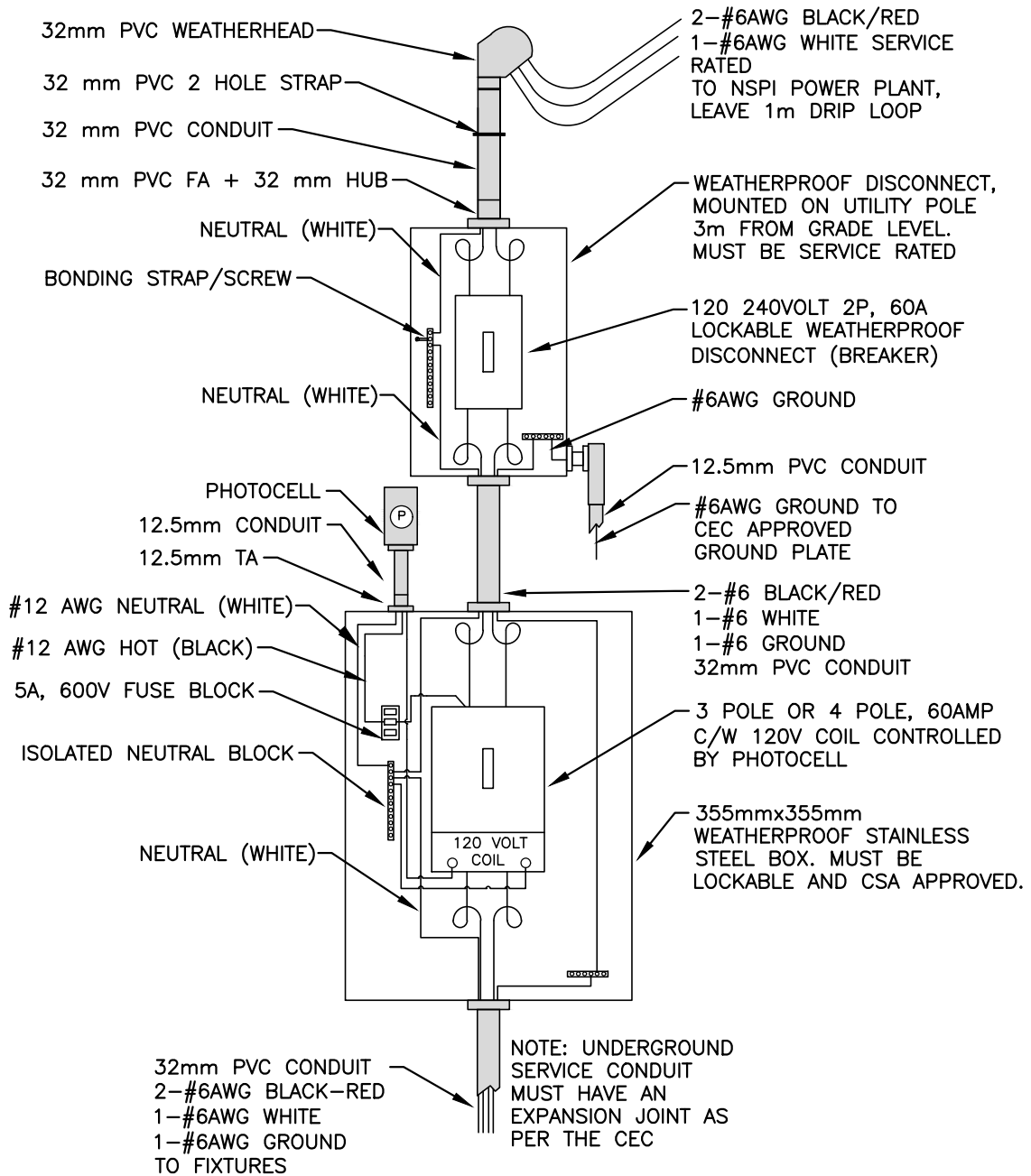

120/240 VOLT SINGLE PHASE CURRENT RATED OVER 15 AMPS

NOTES:

1. BREAKER MUST BE A DOUBLE POLE, NO SPARE SERVICE WIRES ARE ALLOWED.
2. CIRCUITS RATED AT MORE THAN 15 AMPS REQUIRE A CONTACTOR.
3. ALL WORK MUST BE IN ACCORDANCE WITH THE LATEST EDITION OF THE CANADIAN ELECTRICAL CODE AND INSPECTED BY NSPI.
4. UNDERGROUND SERVICE CONDUIT AND GROUND MUST BE PROTECTED BY A U-GUARD AND BONDED AS PER CEC.
5. ALL SCREWS IN THE SERVICE SWITCH ARE TO BE 5. NEVER SEIZED, AND MOUNTING SCREWS ARE TO BE STAINLESS STEEL ONLY.
6. ALL POLES FED OFF OF THIS CAP INSTALLED OR MUST BE CONNECTED DIRECTLY.
7. SERVICE MUST BE MOUNTED AT A MINIMUM OF THREE METERS.

HALIFAX

STANDARD DETAIL

**STREET LIGHTING
U/G ELECTRICAL SERVICE**

DATE:	2021	REFERENCE	APPROVED
SCALE:	NTS		FIG No.: HRM 112

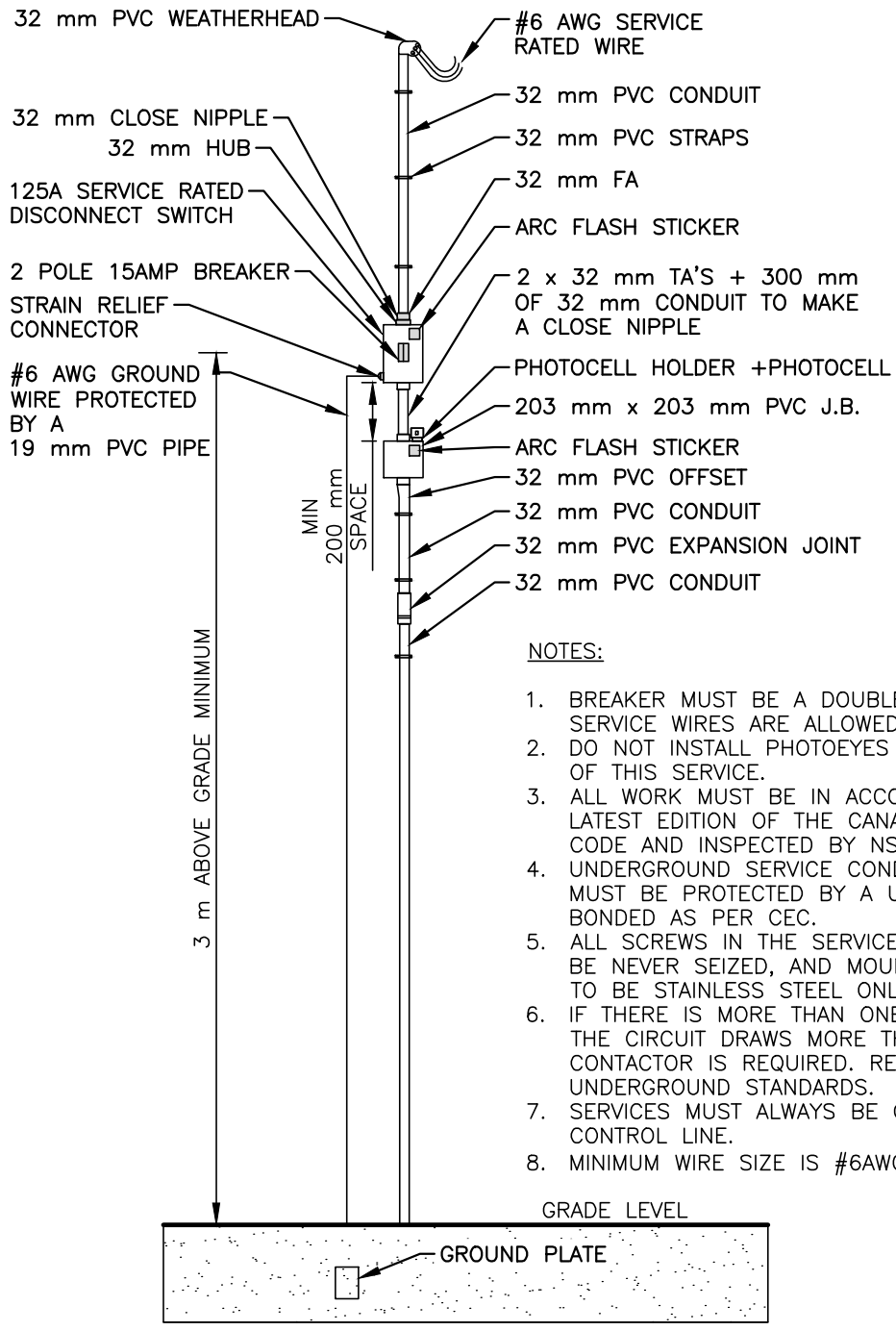

NOTES:

1. BREAKER MUST BE A DOUBLE POLE, NO SPARE SERVICE WIRES ARE ALLOWED.
2. DO NOT INSTALL PHOTOEYES IN POLES FED OFF OF THIS SERVICE.
3. ALL WORK MUST BE IN ACCORDANCE WITH THE LATEST EDITION OF THE CANADIAN ELECTRICAL CODE AND INSPECTED BY NSPI.
4. UNDERGROUND SERVICE CONDUIT AND GROUND MUST BE PROTECTED BY A U-GUARD AND BONDED AS PER CEC.
5. ALL SCREWS IN THE SERVICE SWITCH ARE TO BE NEVER SEIZED, AND MOUNTING SCREWS ARE TO BE STAINLESS STEEL ONLY.
6. IF THERE IS MORE THAN ONE CIRCUIT OR IF THE CIRCUIT DRAWS MORE THAN 15 AMPS A CONTACTOR IS REQUIRED. REFER TO UNDERGROUND STANDARDS.
7. SERVICES MUST ALWAYS BE CONNECTED TO THE CONTROL LINE.
8. MINIMUM WIRE SIZE IS #6AWG.

120 VOLT SINGLE PHASE CURRENT RATED UNDER 15 AMPS

HALIFAX		
STANDARD DETAIL		
STREET LIGHTING		
U/G ELECTRICAL SERVICE		
DATE:	REFERENCE	APPROVED
2021		
SCALE:		FIG No.:
NTS		HRM 113

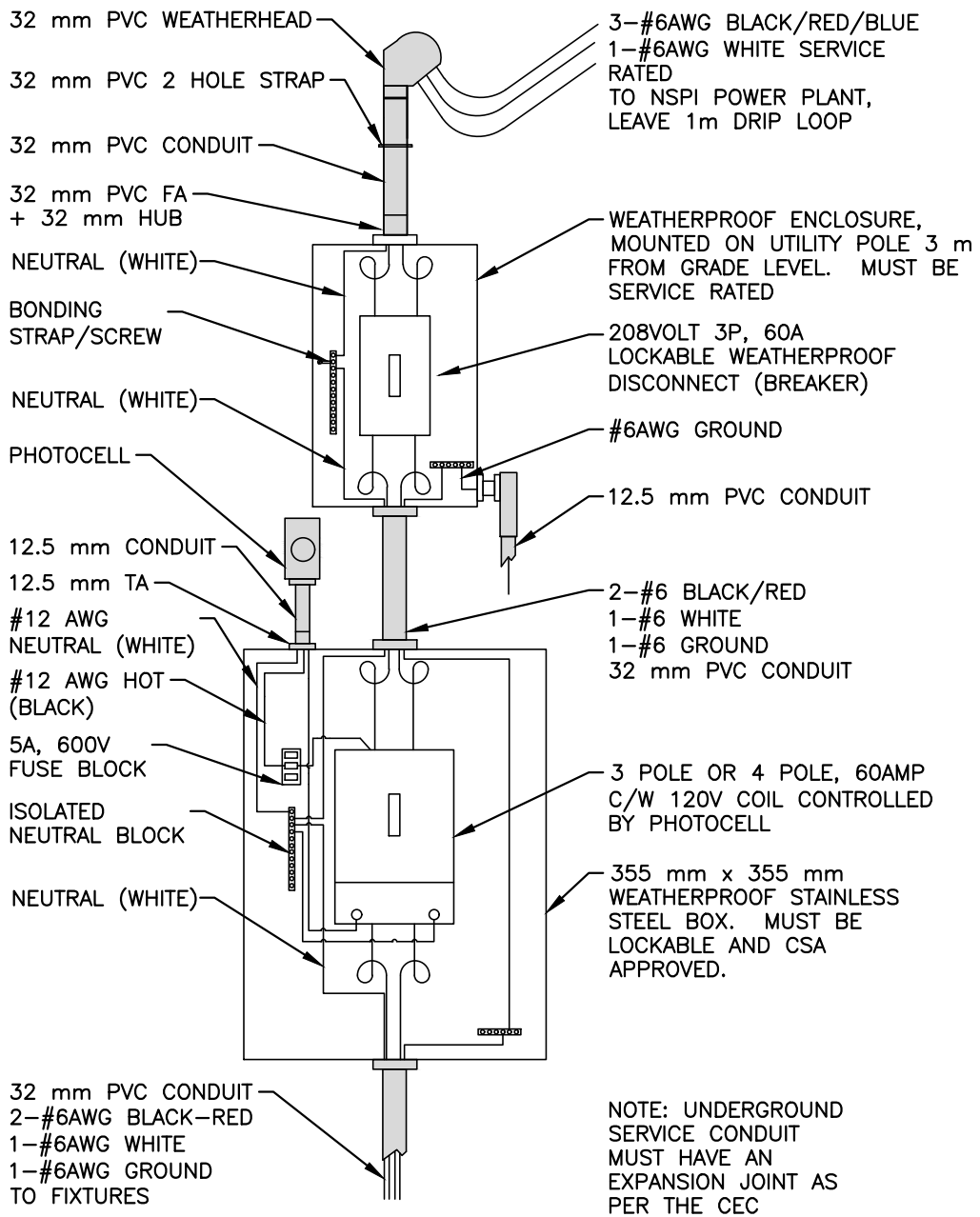

208 VOLT THREE PHASE CURRENT RATED OVER 15 AMPS

NOTES:

1. BREAKER MUST BE A DOUBLE POLE, NO SPARE SERVICE WIRES ARE ALLOWED.
2. CIRCUITS RATED AT MORE THAN 15 AMPS REQUIRE A CONTACTOR.
3. ALL WORK MUST BE IN ACCORDANCE WITH THE LATEST EDITION OF THE CANADIAN ELECTRICAL CODE AND INSPECTED BY NSPI.
4. UNDERGROUND SERVICE CONDUIT AND GROUND MUST BE PROTECTED BY A U-GUARD AND BONDED AS PER CEC.
5. ALL SCREWS IN THE SERVICE SWITCH ARE TO BE NEVER SEIZED, AND MOUNTING SCREWS ARE TO BE STAINLESS STEEL ONLY.
6. ALL POLES FED OFF OF THIS SERVICE MUST HAVE A SHORTING CAP INSTALLED OR MUST BE CONNECTED DIRECTLY.

<h1>HALIFAX</h1>		
STANDARD DETAIL		
STREET LIGHTING		
U/G ELECTRICAL SERVICE		
DATE:	REFERENCE	APPROVED
2021		
SCALE:		FIG No.:
NTS		HRM 114

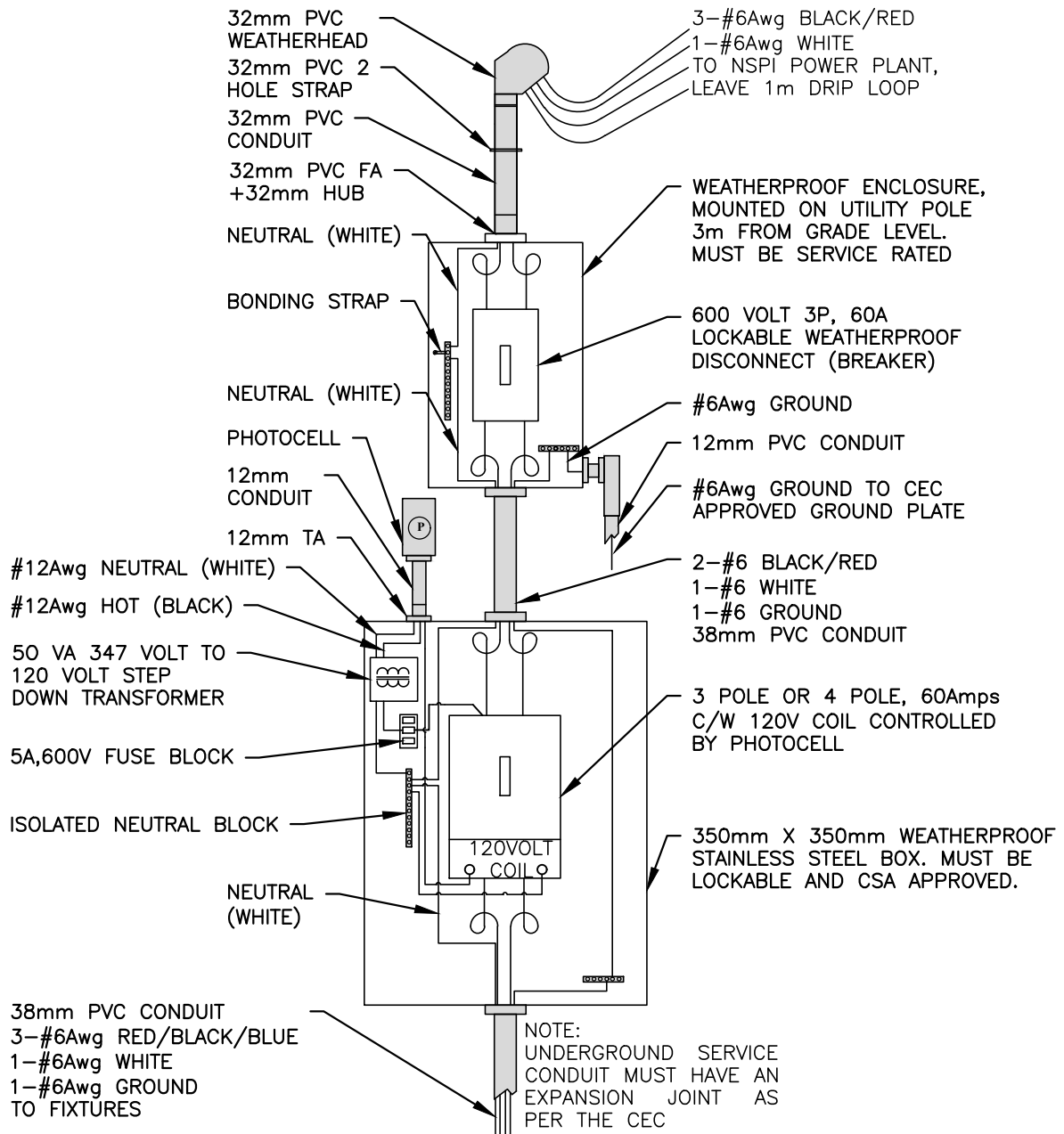

NOTES:

1. BREAKER MUST BE A DOUBLE POLE, NO SPARE SERVICE WIRES ARE ALLOWED.
2. CIRCUITS RATED AT MORE THAN 15Amps REQUIRE A CONTACTOR.
3. ALL WORK MUST BE IN COMPLIANCE WITH THE LATEST EDITION OF THE CANADIAN ELECTRICAL CODE AND INSPECTED BY NSPI.
4. UNDERGROUND SERVICE CONDUIT AND GROUND MUST BE PROTECTED BY A U-GUARD AND BONDED AS PER CEC.
5. ALL SCREWS IN THE SERVICE SWITCH ARE TO BE NEVER SEIZED, AND MOUNTING SCREWS ARE TO BE STAINLESS STEEL ONLY.
6. ALL POLES FED OFF THIS SERVICE MUST HAVE A SHORTING CAP INSTALLED OR MUST BE CONNECTED DIRECTLY.
7. SERVICE MUST BE MOUNTED AT MINIMUM OF THREE METERS.

HALIFAX

STANDARD DETAIL

347 VOLT 3 PHASE U/G SERVICE OVER 15Amps

DATE:	2021	REFERENCE	APPROVED
SCALE:	NTS		FIG No.: HRM 115

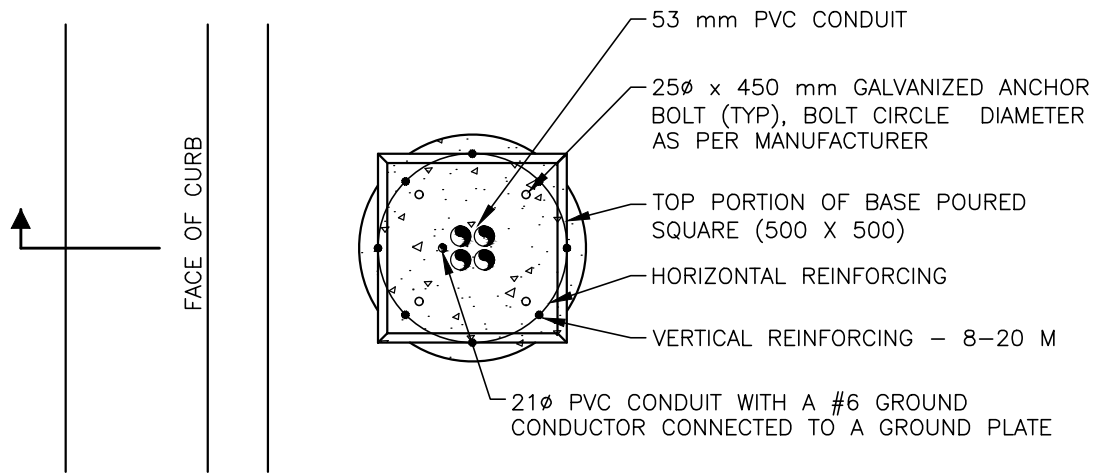

PLAN

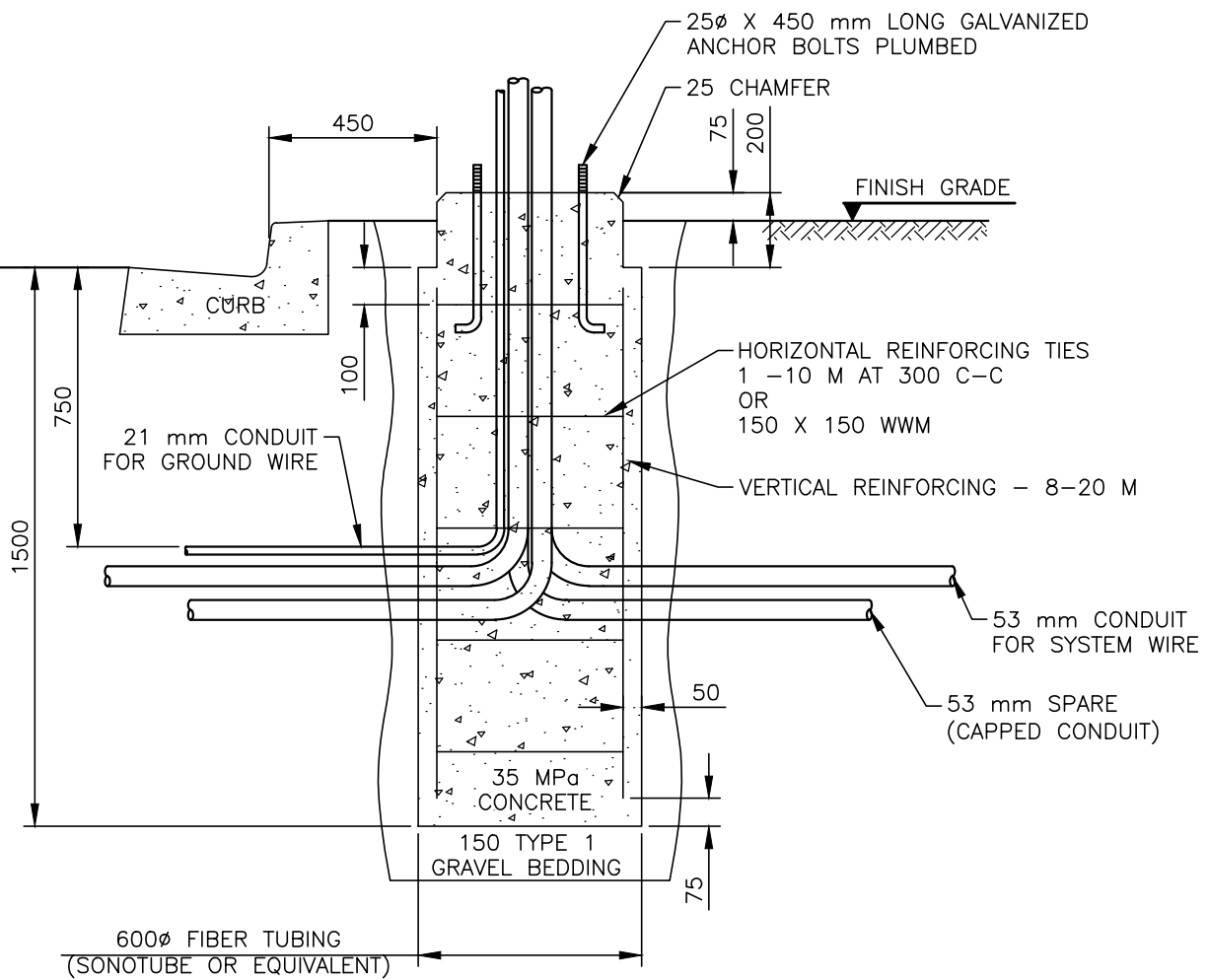

SECTION

NOTES:

1. CONCRETE MUST BE PLACED IN A SINGLE POUR.
2. ALL DIMENSIONS IN MILLIMETRES.
3. ALL WORK MUST BE IN COMPLIANCE WITH THE LATEST EDITION OF THE CANADIAN ELECTRICAL CODE.
4. THE THREADS OF THE LEG BOLTS MUST BE LEVEL WITH THE TOP OF THE CONCRETE BASE.
5. EACH CONCRETE BASE MUST HAVE ITS OWN GROUND PLATE
6. CONTRACTOR TO PLACE CONDUIT TO ALLOW FOR A DIVIDER PLATE IN THE TRANSFORMED BASE/POLE.

HALIFAX

STANDARD DETAIL

ORNAMENTAL STREET LIGHT BASE

DATE:	REFERENCE	APPROVED
2021		
SCALE:		FIG No.:
1:20		HRM 116

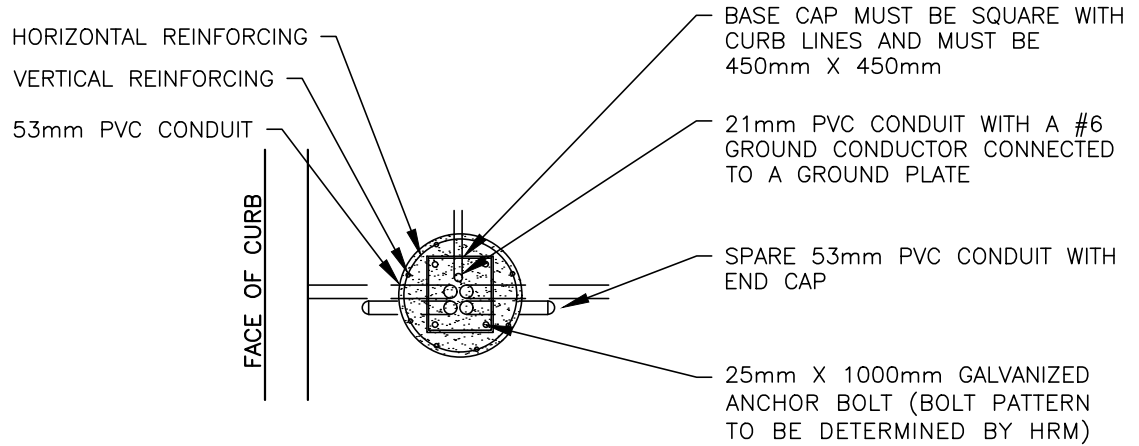

PLAN

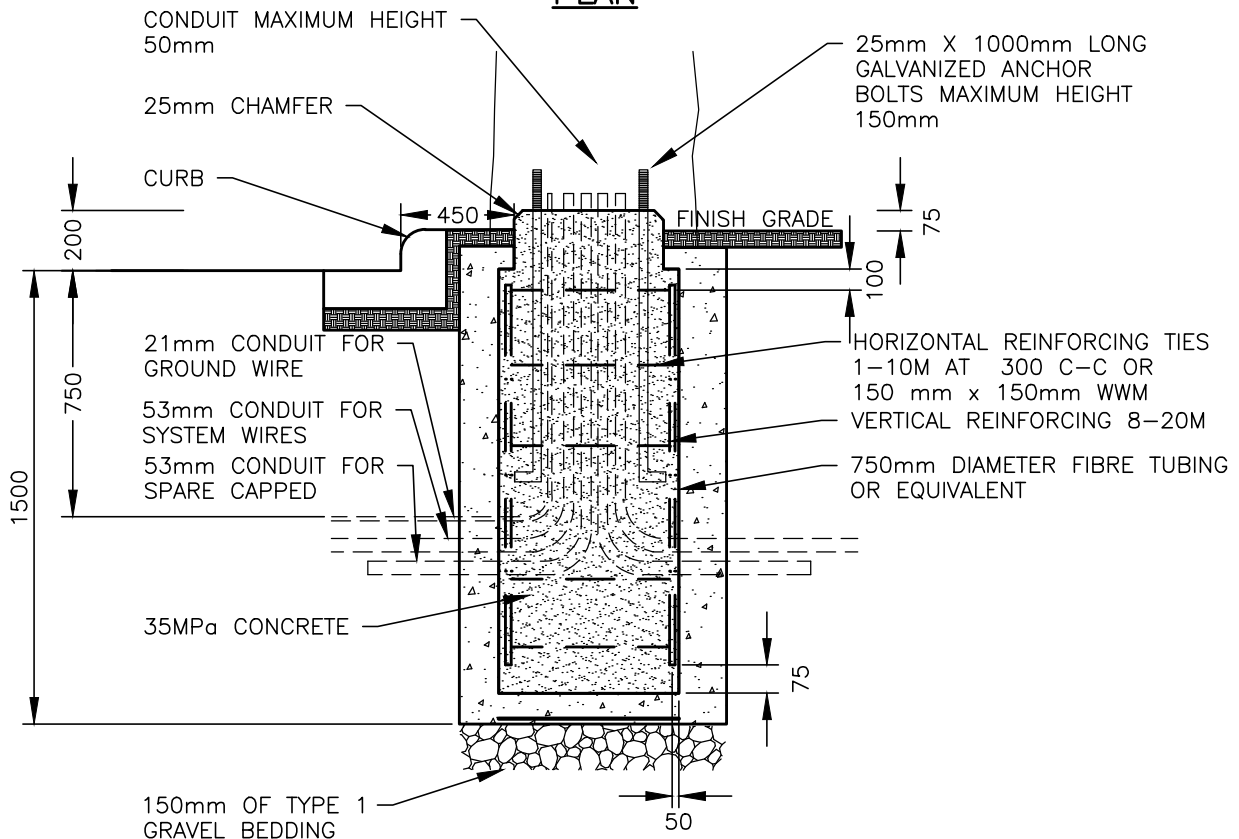

SECTION

NOTES:

1. ALL WORK MUST BE IN COMPLIANCE WITH THE LATEST EDITION OF THE CANADIAN ELECTRICAL CODE.
2. ALL CONCRETE MUST BE POURED IN ONE POUR.
3. THE THREADS OF THE LEG BOLTS MUST BE LEVEL WITH TOP ON THE CONCRETE BASE.
4. EACH CONCRETE BASE MUST HAVE ITS OWN GROUND PLATE.

HALIFAX

STANDARD DETAIL

STANDARD ALUMINIUM STREET LIGHT BASE TYPE 2

DATE:	2021	REFERENCE	APPROVED
SCALE:	NTS		FIG No.: HRM 117

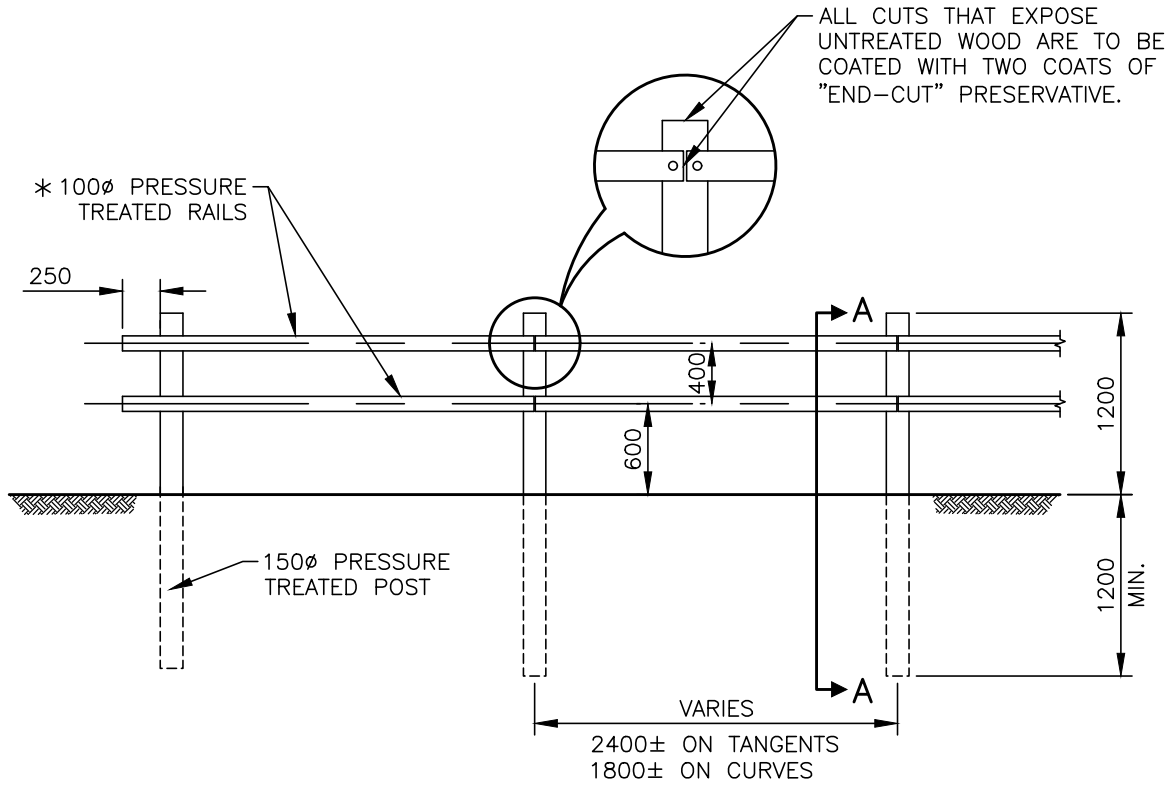

ELEVATION

SCALE: 1:50

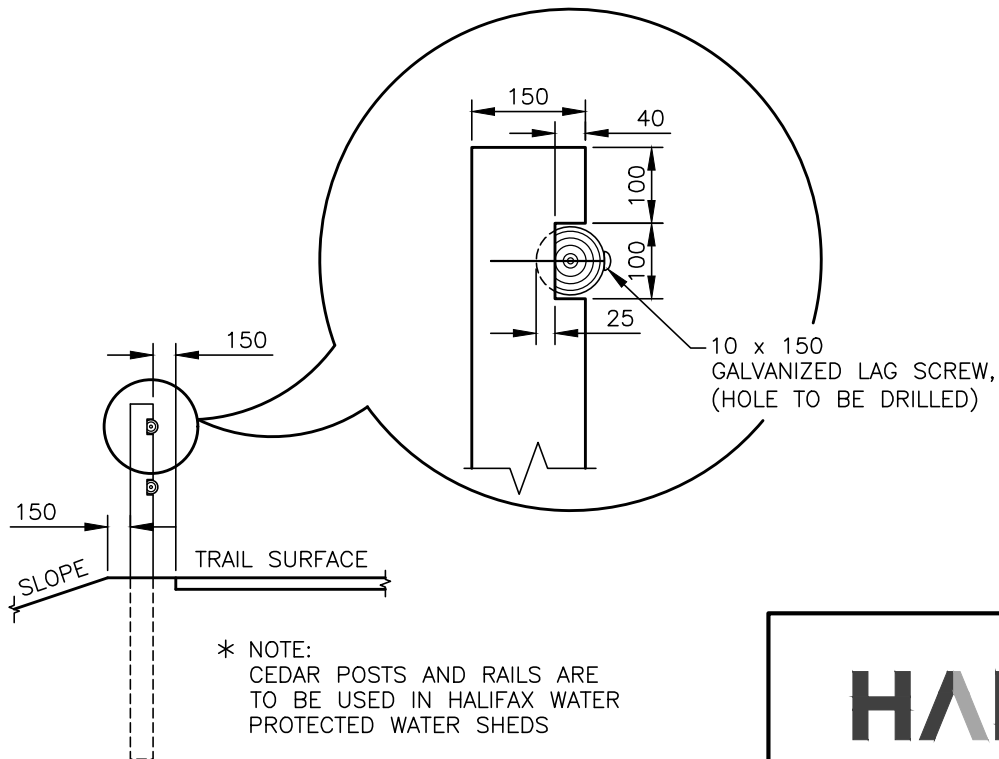

SECTION A-A

SCALE 1:50

HALIFAX

STANDARD DETAIL

WOODEN FENCE

DATE:	2021	REFERENCE	APPROVED
SCALE:	1:50		FIG No.: HRM 118

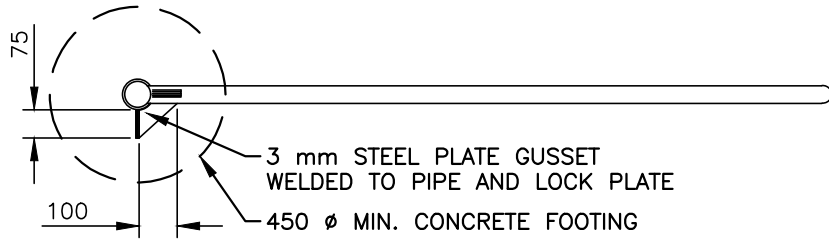

PLAN

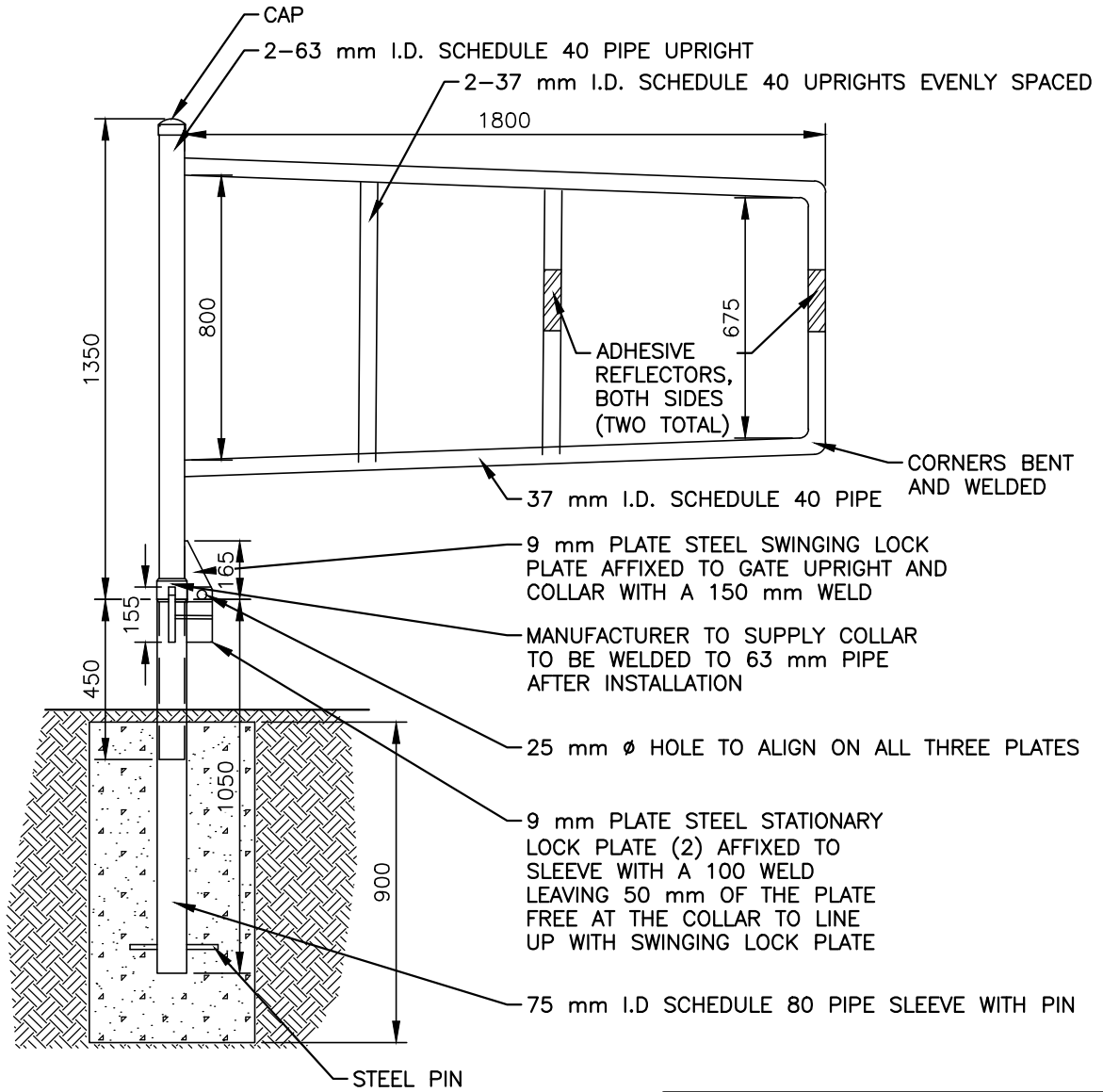

SECTION

NOTES:

1. ALL PIPE TO BE GALVANIZED EXCEPT 75 mm GROUND SLEEVE (BLACK IRON)
2. ALL WORK TO BE DONE ACCORDING TO HRM SPECIFICATIONS
3. ALL METAL TO RECEIVE ONE COAT OF RUST INHIBITING PRIMER AND TWO COATS OF R&M PAINT E1245 CODE L (HOLLY GREEN) ENAMEL AUTOMOTIVE PAINT.

HALIFAX

STANDARD DETAIL

PEDESTRIAN GATE

DATE:	2021	REFERENCE	APPROVED
SCALE:	NTS		FIG No.: HRM 119

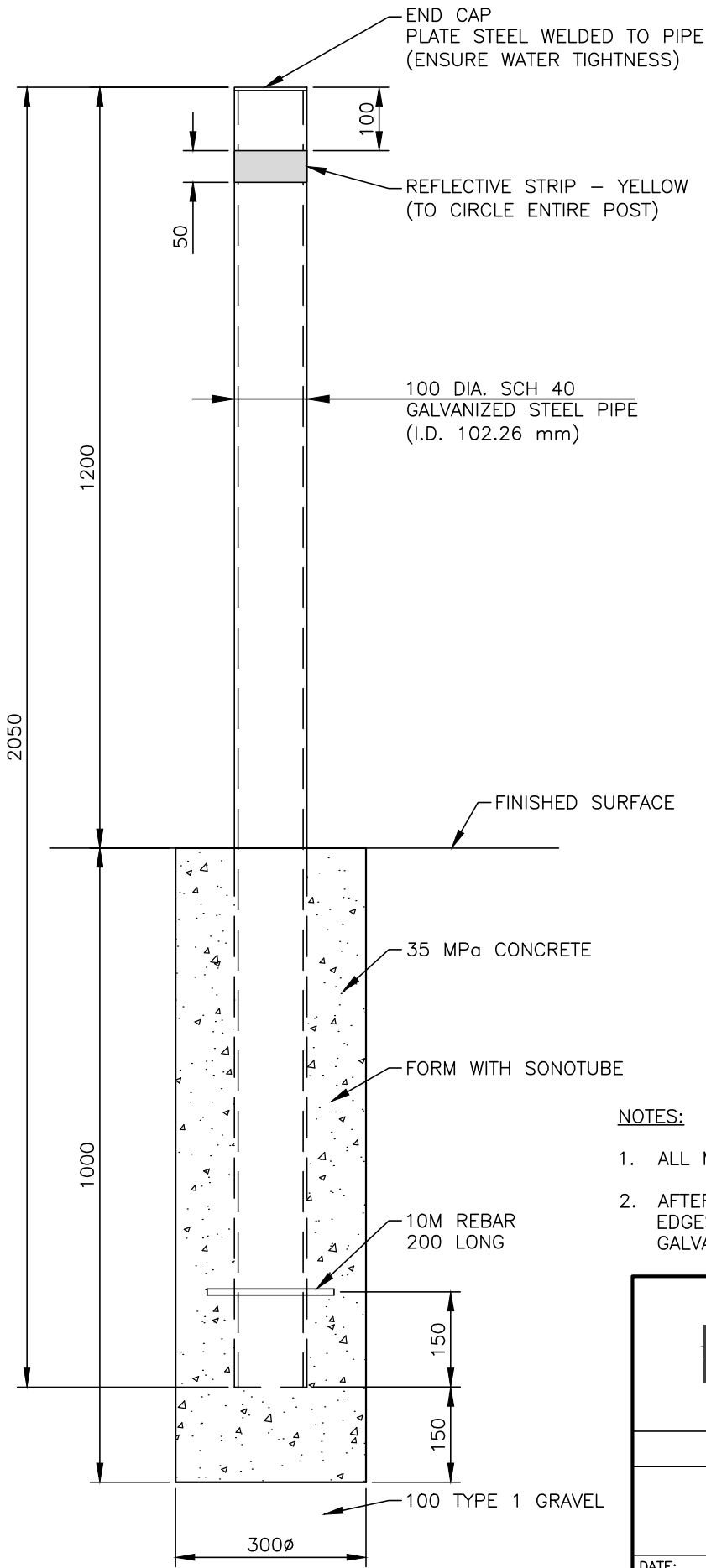

NOTES:

1. ALL METAL TO BE HOT DIPPED GALVANIZED.
2. AFTER INSTALLATION, ANY EXPOSED METAL EDGES SHALL BE PROTECTED WITH COLD GALVANIZING.

HALIFAX		
STANDARD DETAIL		
BOLLARD		
DATE:	REFERENCE	APPROVED
2021		
SCALE:		FIG No.:
NTS		HRM 120

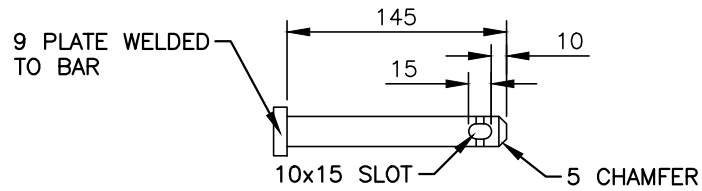
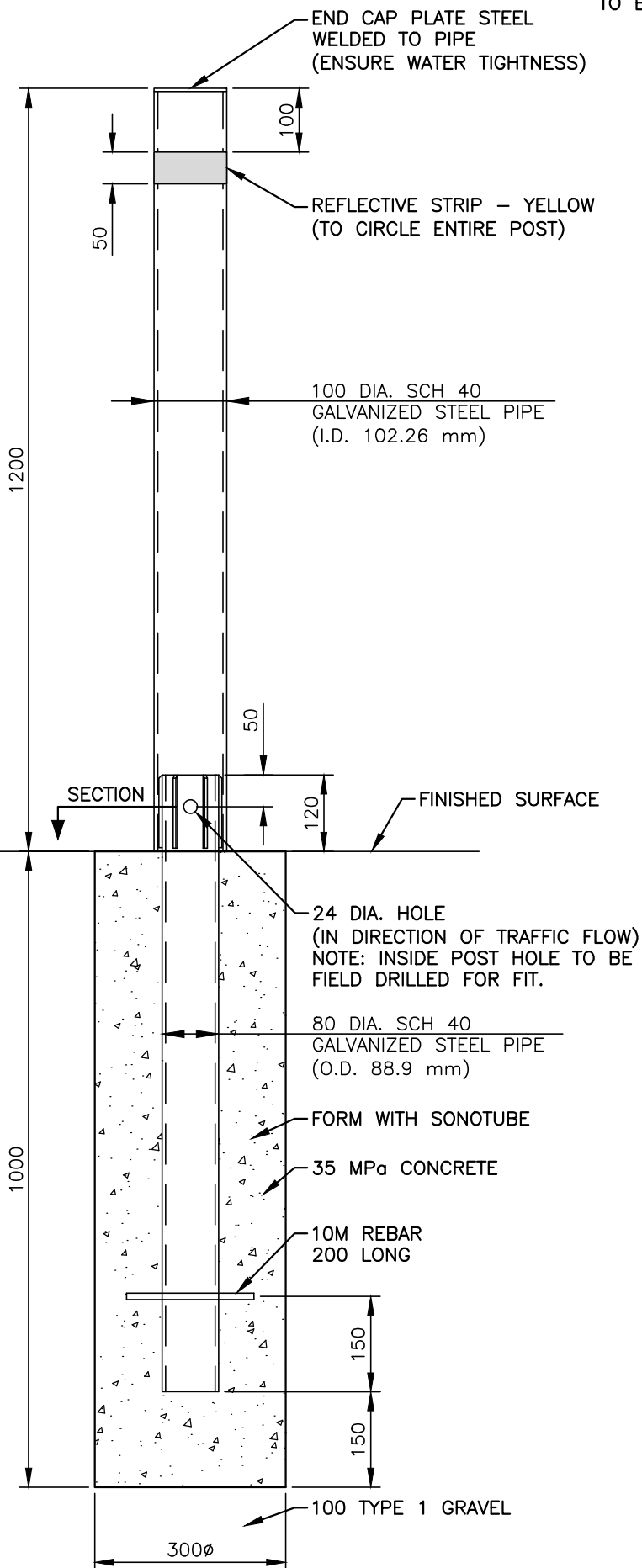

TOP VIEW

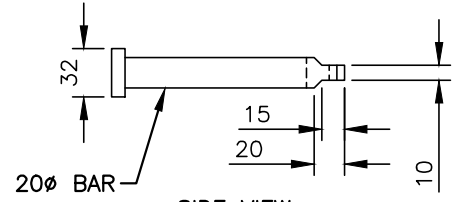

SIDE VIEW

PIN DETAIL

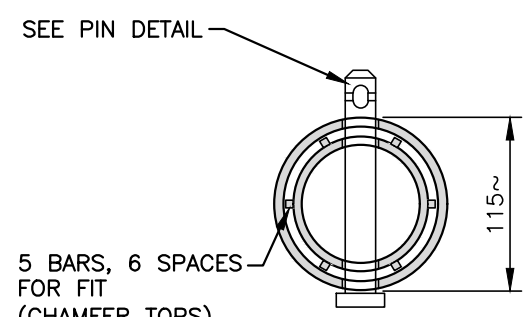

SECTION

NOTES:

1. ALL METAL TO BE HOT DIPPED GALVANIZED.
2. AFTER INSTALLATION, ANY EXPOSED METAL EDGES SHALL BE PROTECTED WITH COLD GALVANIZING.
3. DIMENSIONS ARE IN MILLIMETRES.

HALIFAX		
STANDARD DETAIL		
BOLLARD – REMOVABLE		
DATE:	REFERENCE	APPROVED
2021		
SCALE:		FIG No.:
NTS		HRM 121

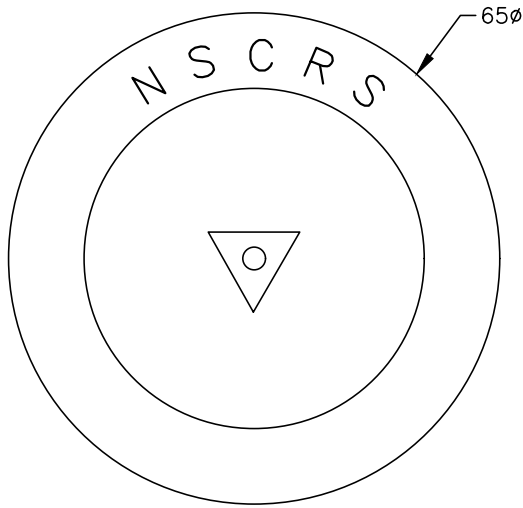

PLAN

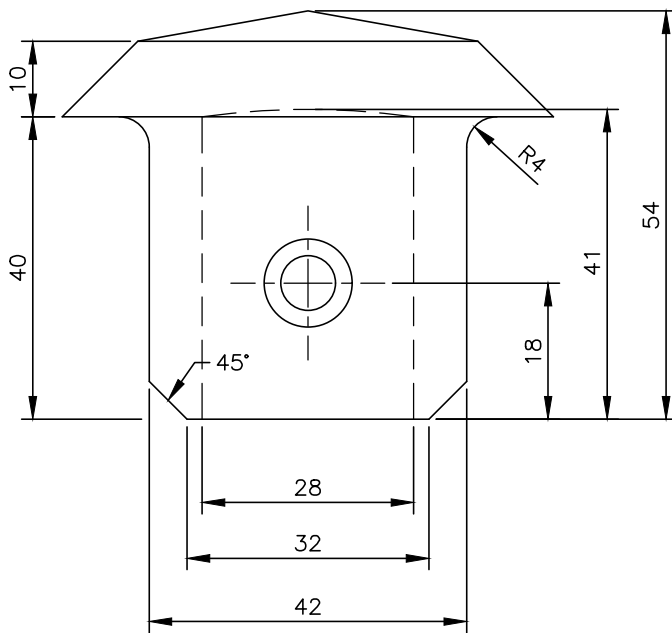

SECTION

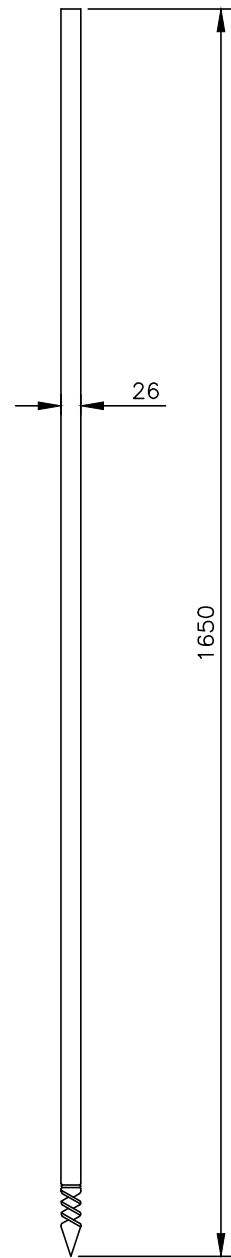

NOTE:

DIMENSIONS ARE IN MILLIMETRES.

HALIFAX

STANDARD DETAIL

SURVEY MONUMENT

DATE:	2021	REFERENCE	APPROVED
SCALE:	NTS		FIG No.: HRM 122

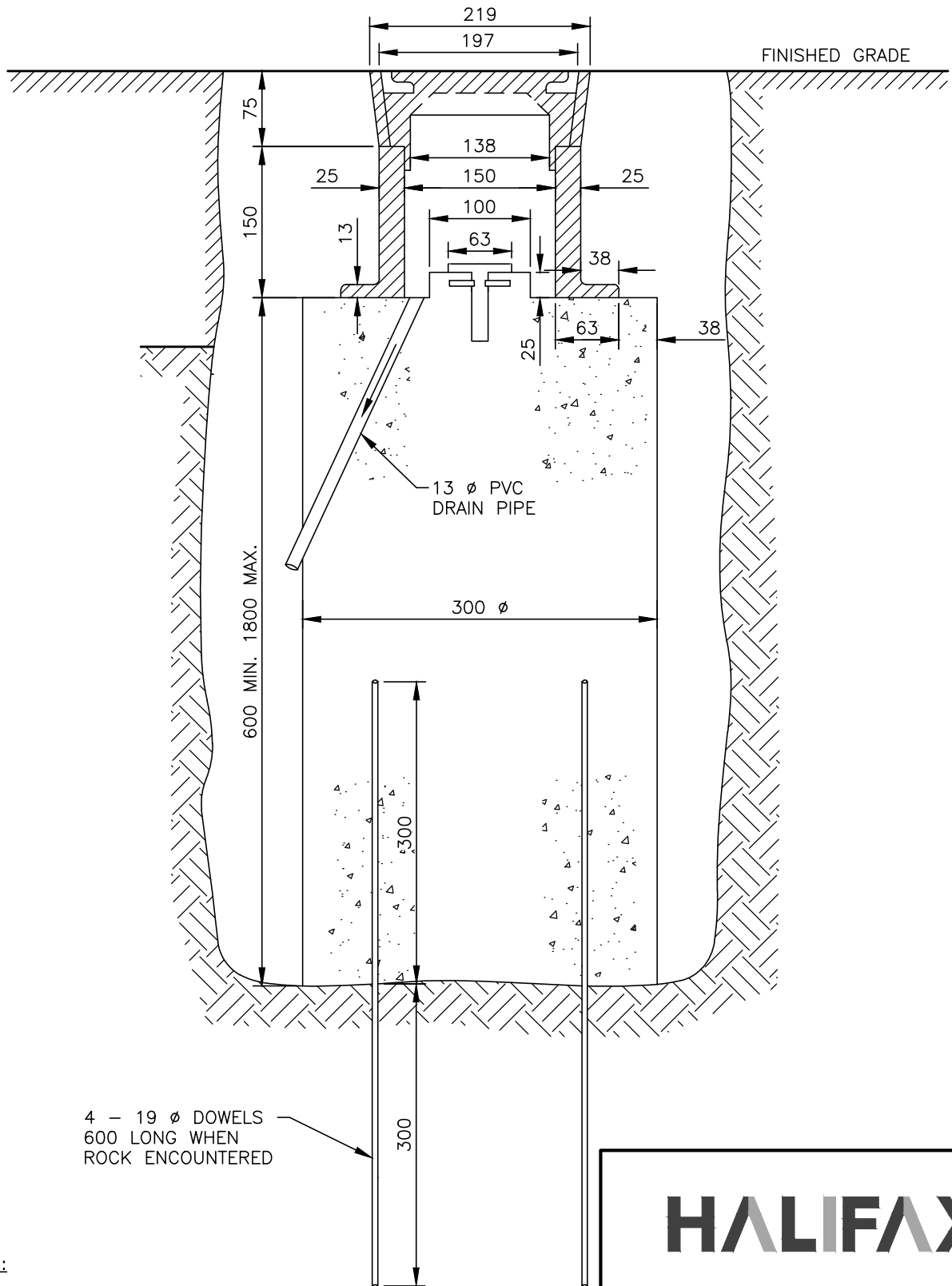

4 - 19 ϕ DOWELS
600 LONG WHEN
ROCK ENCOUNTERED

NOTES:

1. WHEN ROCK BASE IS ENCOUNTERED. ANCHORS OR DOWELING TO BE USED.
2. CAST IRON FRAME AND COVER TO BE SUPPLIED BY HRM.
3. DIMENSIONS ARE IN MILLIMETRES.

HALIFAX

STANDARD DETAIL
**SURVEY MONUMENT
TYPE I**

DATE:	2021	REFERENCE	APPROVED
SCALE:	NTS		FIG No.: HRM 124

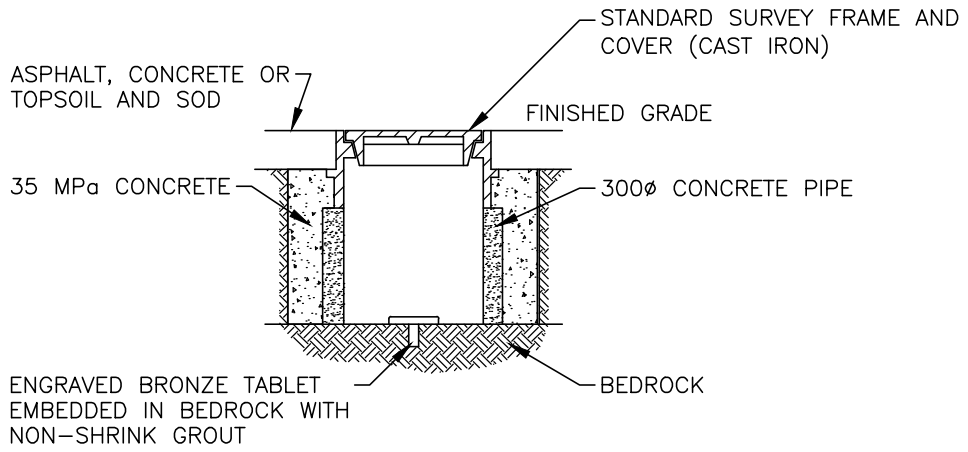

WHEN BEDROCK ENCOUNTERED BETWEEN 150 AND 450 BELOW SURFACE

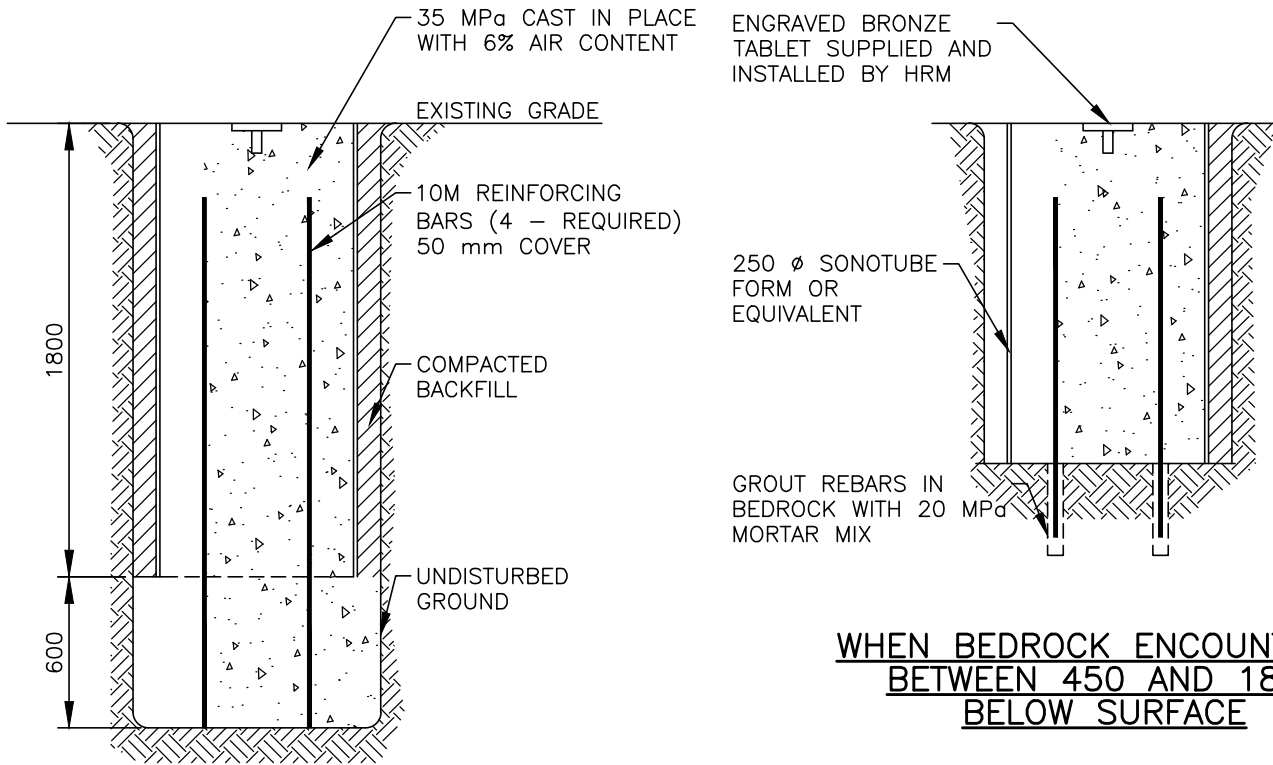

WHEN BEDROCK ENCOUNTERED BETWEEN 450 AND 1800 BELOW SURFACE

WHEN BEDROCK IS NOT ENCOUNTERED 2400 + BELOW SURFACE

HALIFAX

STANDARD DETAIL

**SURVEY MONUMENT
TYPE II**

DATE:	2021	REFERENCE	APPROVED
SCALE:	NTS		FIG No.: HRM 125

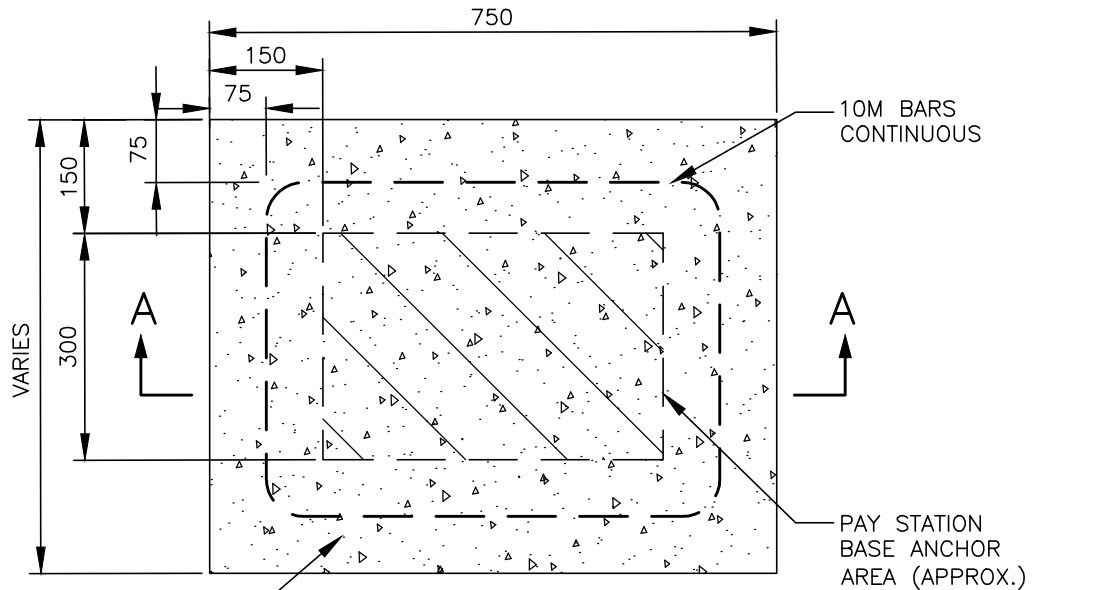

BROOM FINISH
TOP OF BASE

PLAN

N.T.S.

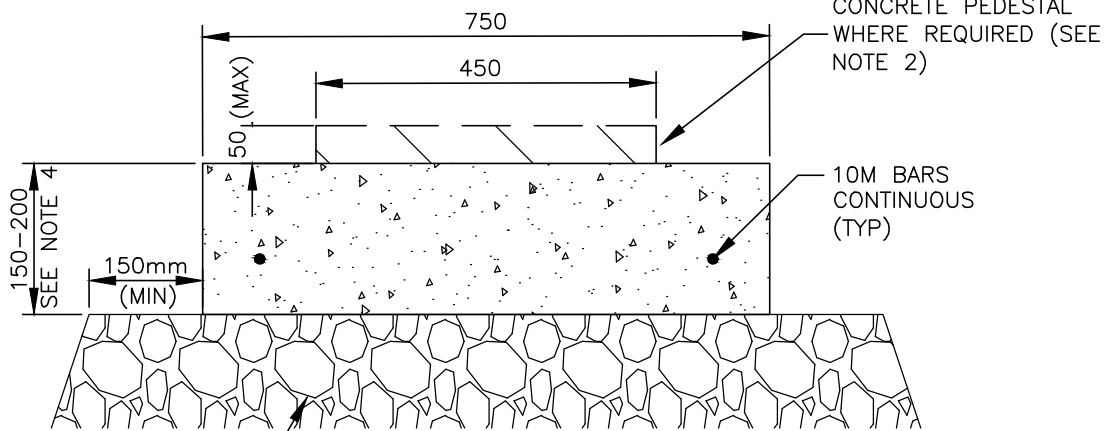

SECTION A-A

N.T.S.

NOTES :

1. BASE TOP SHALL BE FLUSH WITH EXISTING SIDEWALK.
2. INSTALL LEVEL PEDESTAL WITH BASE WHERE EXISTING GRADE EXCEEDS 3.5%.
3. CONCRETE MUST BE PLACED IN A SINGLE POUR.
4. CONCRETE BASE TO BE 200mm UNDER PAY STATION BASE ANCHOR AREA. MIN 150mm OTHERWISE
5. DOWEL INTO EXISTING SIDEWALK WHERE PRESENT. MIN 2-10M DOWELS EACH SIDE. 150mm EMBEDMENT.
6. ENSURE EXISTING SIDEWALK IS NOT UNDERMINED BY WORK.
7. BROOM FINISH AND EDGE PERIMETER OF ALL EXPOSED CONCRETE SURFACES.

HALIFAX

STANDARD DETAIL

**PARKING PAY STATION BASE
(TYPICAL)**

DATE:	2021	REFERENCE	APPROVED
SCALE:	AS NOTED		FIG No.: HRM 126A

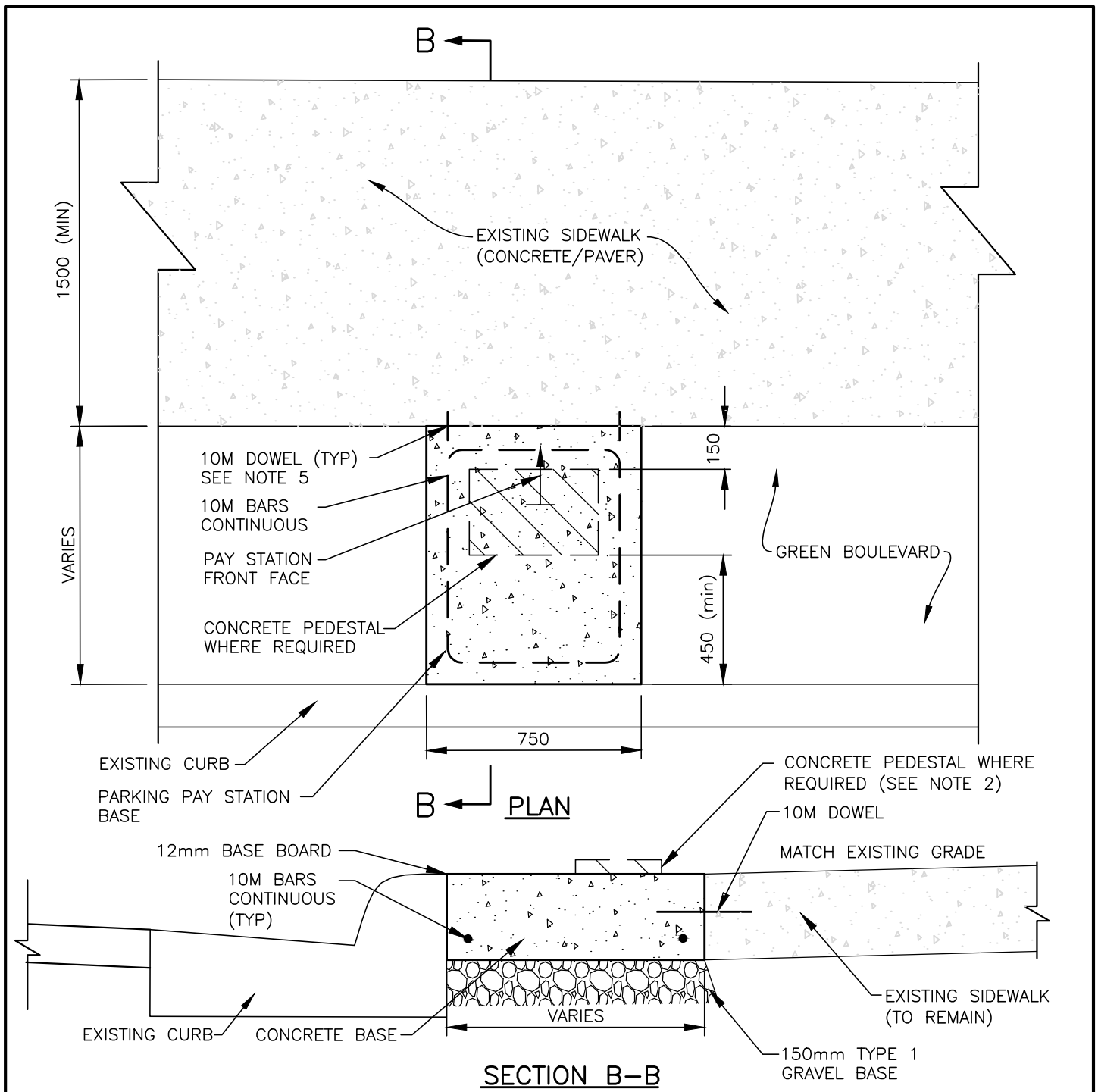

NOTES:

1. BASE TOP SHALL BE FLUSH WITH EXISTING SIDEWALK.
2. INSTALL LEVEL PEDESTAL WITH BASE WHERE EXISTING GRADE EXCEEDS 3.5%.
3. CONCRETE MUST BE PLACED IN A SINGLE POUR.
4. CONCRETE BASE TO BE 200mm UNDER PAY STATION BASE ANCHOR AREA. MIN 150mm OTHERWISE
5. DOWEL INTO EXISTING SIDEWALK WHERE PRESENT. MIN 2-10M DOWELS EACH SIDE. 150mm EMBEDMENT.
6. ENSURE EXISTING SIDEWALK IS NOT UNDERMINED BY WORK.
7. BROOM FINISH AND EDGE PERIMETER OF ALL EXPOSED CONCRETE SURFACES.

HALIFAX

STANDARD DETAIL

**PARKING PAY STATION BASE
ON EXISTING GREEN BOULEVARD**

DATE: 2021	REFERENCE	APPROVED
SCALE: AS NOTED		FIG No.: HRM 126B

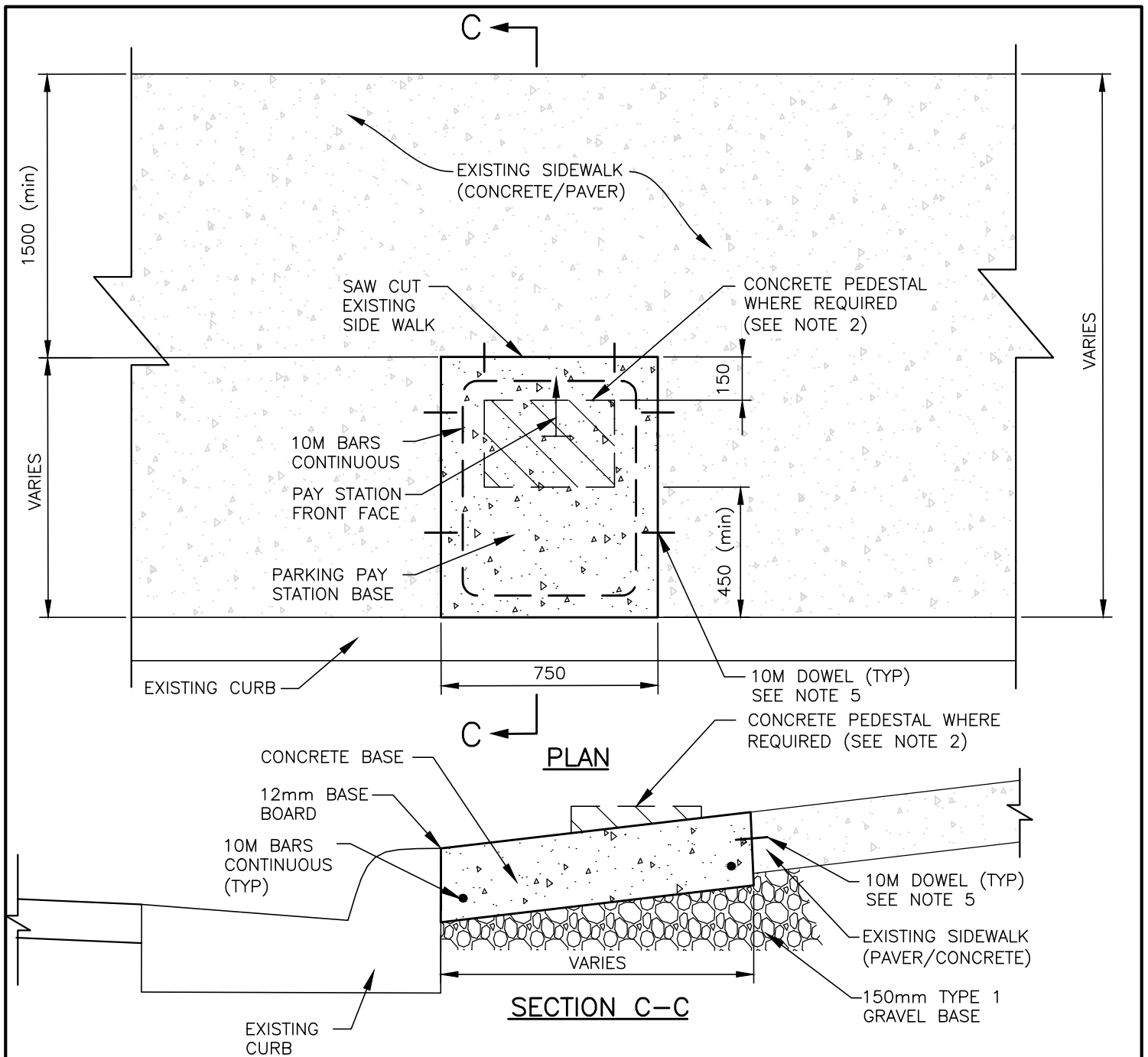

NOTES :

1. BASE TOP SHALL BE FLUSH WITH EXISTING SIDEWALK.
2. INSTALL LEVEL PEDESTAL WITH BASE WHERE EXISTING GRADE EXCEEDS 3.5%.
3. CONCRETE MUST BE PLACED IN A SINGLE POUR.
4. CONCRETE BASE TO BE 200mm UNDER PAY STATION BASE ANCHOR AREA. MIN 150mm OTHERWISE
5. DOWEL INTO EXISTING SIDEWALK WHERE PRESENT. MIN 2-10M DOWELS EACH SIDE. 150mm EMBEDMENT.
6. ENSURE EXISTING SIDEWALK IS NOT UNDERMINED BY WORK.
7. BROOM FINISH AND EDGE PERIMETER OF ALL EXPOSED CONCRETE SURFACES.

HALIFAX		
STANDARD DETAIL		
PARKING PAY STATION BASE ON EXISTING SIDEWALK		
DATE:	REFERENCE	APPROVED
2021		
SCALE:		FIG No.:
AS NOTED		HRM 126C



HALIFAX

STANDARD DETAIL

CORE BOUNDARY

DATE:	2021	REFERENCE	APPROVED
SCALE:	1:250,000		FIG No.: HRM 127

NOTES:

1. NATURAL CAST IRON ATTENTION TWSI (TACTILE WALKING SURFACE INDICATOR) PLATES. TO CSA B651, AND AS INDICATED IN THE PROJECT DOCUMENTS.
2. MAXIMUM GAP BETWEEN PLATES AND START OF TAPER TO BE 100mm.
3. PLATES SHALL BE PLACED WITH THE TOP OF THE BASE PLATE (BOTTOM OF DOMES) LEVEL WITH CONCRETE SURFACE.
4. ALL PLATES TO BE 610mm LONG.
5. TO BE READ IN CONJUNCTION WITH HRM DETAIL 49 PEDESTRIAN RAMP ALIGNMENT.
6. SIZE AND SHAPE OF PLATES TO MANUFACTURER'S SPECIFICATION.

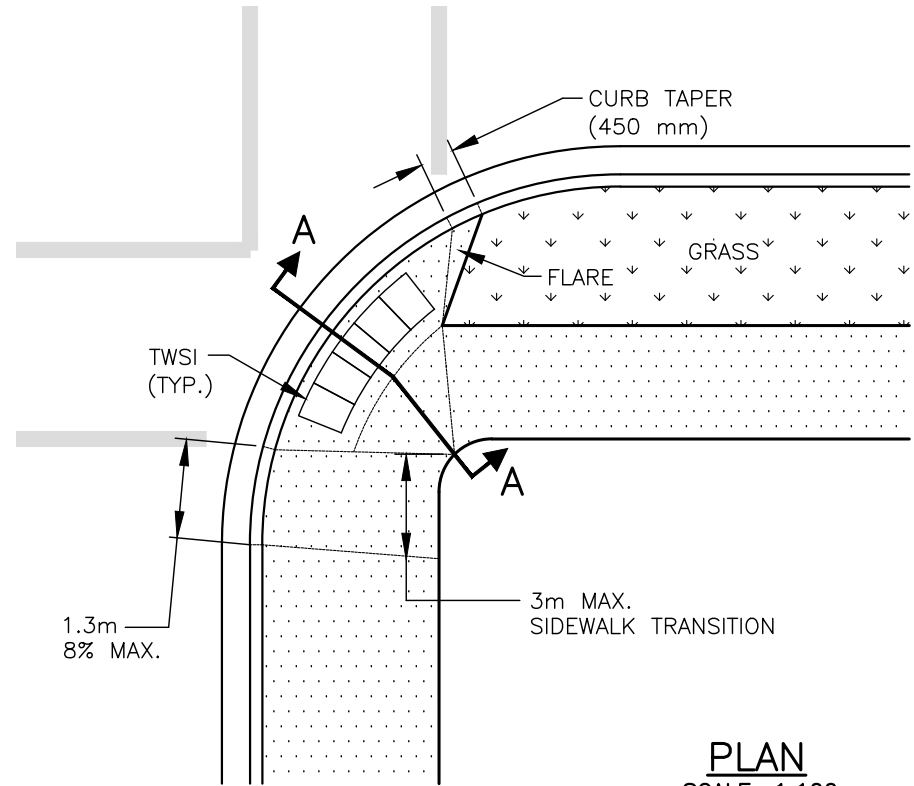

PLAN
SCALE: 1:100

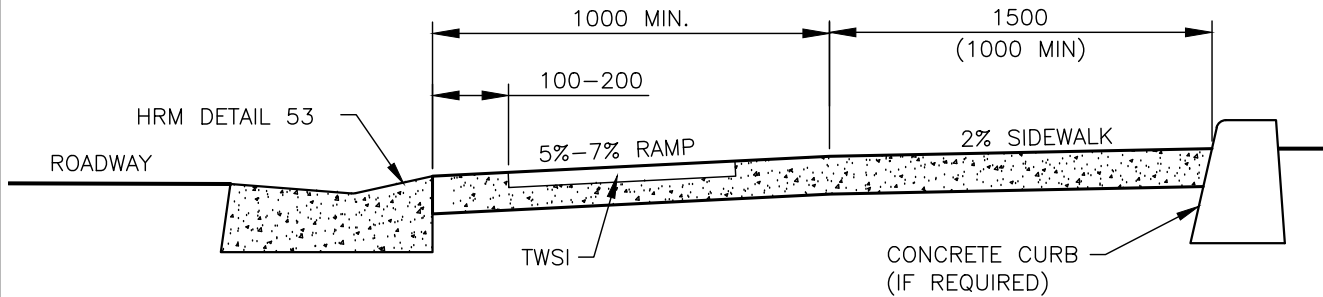

CROSS SECTION A-A
SCALE 1:20

HALIFAX

STANDARD DETAIL

**TACTILE WALKING SURFACE
INDICATOR RAMP PLACEMENT**

DATE: 2021	REFERENCE	APPROVED
SCALE: AS NOTED		FIG No.: HRM 131

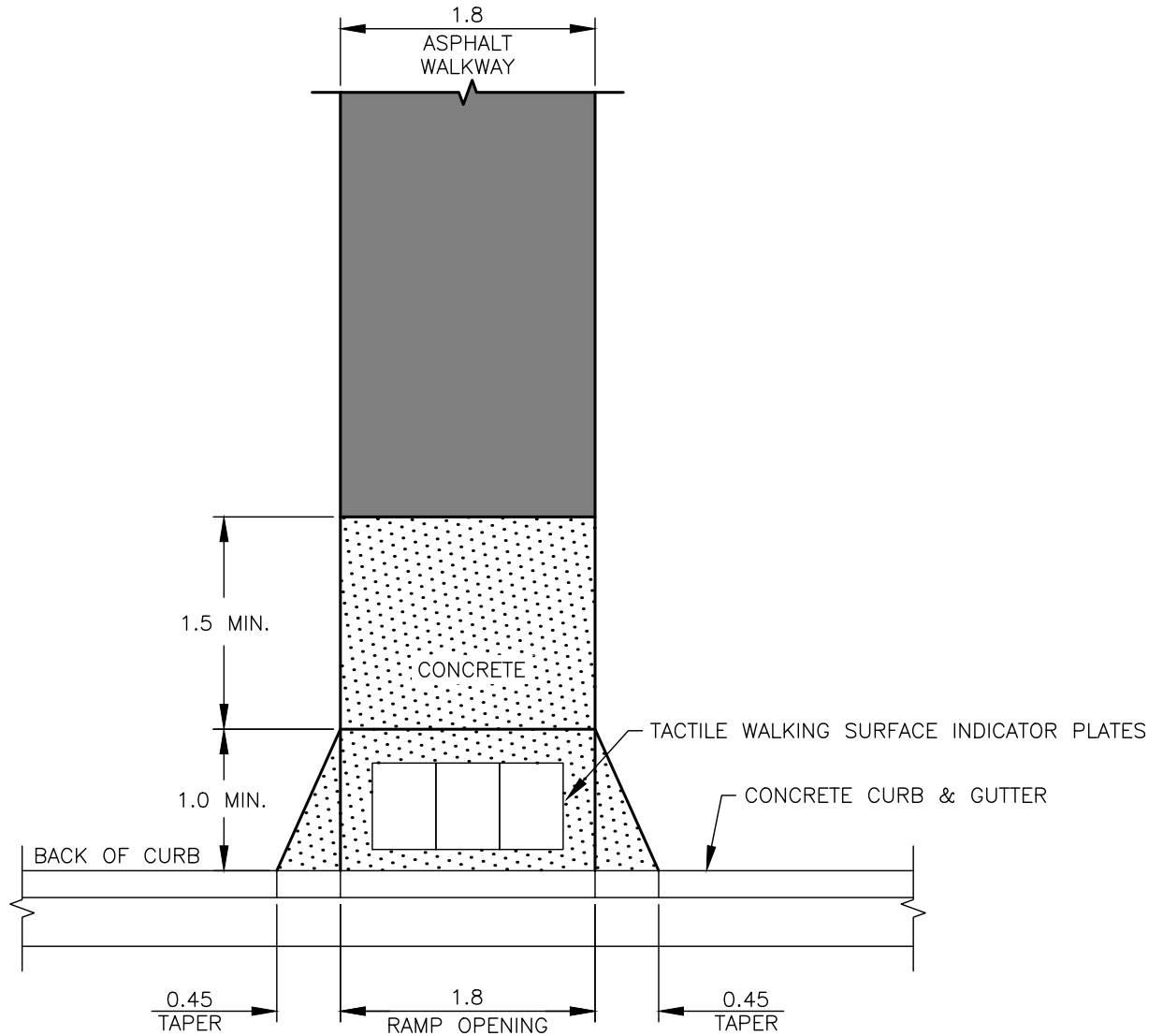

NOTES:

1. CONCRETE PEDESTRIAN RAMP TO HRM DETAIL 49.
2. CONCRETE CURB & GUTTER TO HRM DETAIL 53.
3. TACTILE WALKING SURFACE INDICATOR PLATES TO HRM DETAIL 131.
4. ASPHALT WALKWAY TO HRM DETAIL 40.

HALIFAX

STANDARD DETAIL

WALKWAY WITH
PEDESTRIAN RAMP

DATE:	2021	REFERENCE	APPROVED
SCALE:	1:50		FIG No.: HRM 132

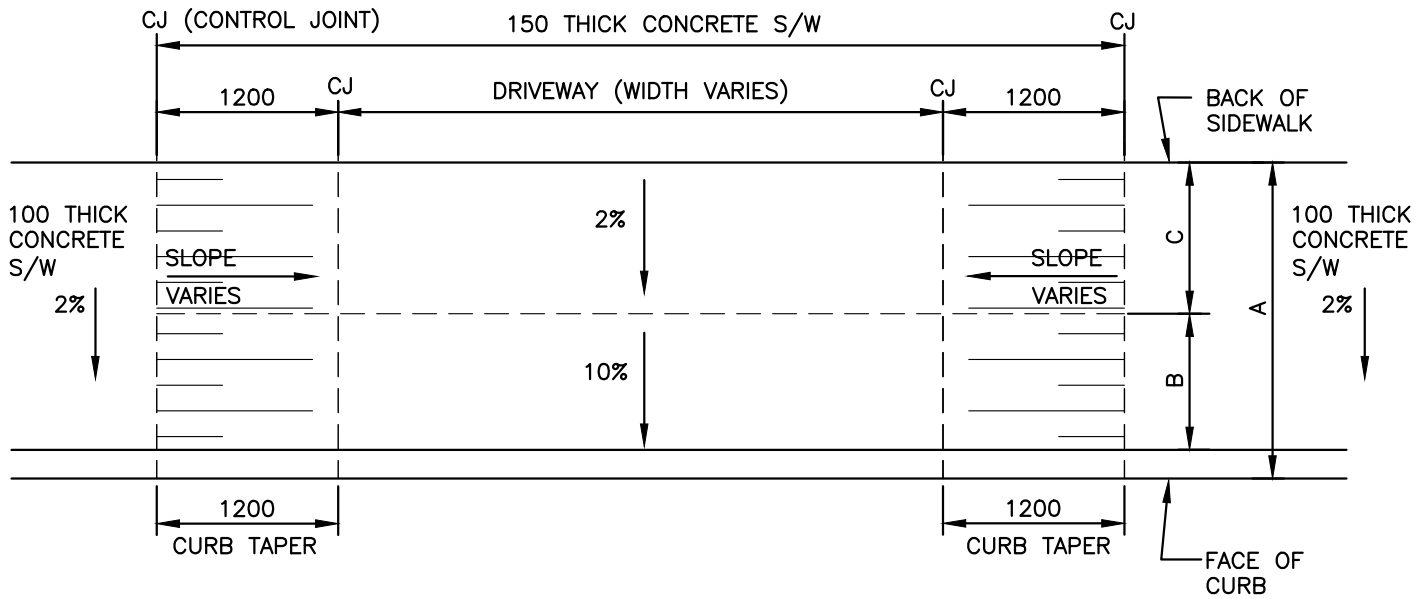

A	B	C	D
1800	600	1000	57
1900	700	1000	49
2000	800	1000	41
2100	900	1000	33
2200	900	1100	33
2300	900	1200	33
2400	900	1300	33
2500	900	1400	33
2600	900	1500	33
2700	1000	1500	24
2800	1100	1500	16
2900	1200	1500	8
3000	1300	1500	0

NOTES:

1. WHEN ADJACENT DRIVEWAYS ARE LESS THAN 2.4 METERS APART, DO NOT TAPER CURB AND SIDEWALK BETWEEN DRIVEWAYS.
2. AREA BEHIND DROPPED S/W MAY REQUIRE BUILD UP WITH PAVEMENT OR CURB TO PREVENT ENTRY OF STORM WATER DURING MAJOR STORM.

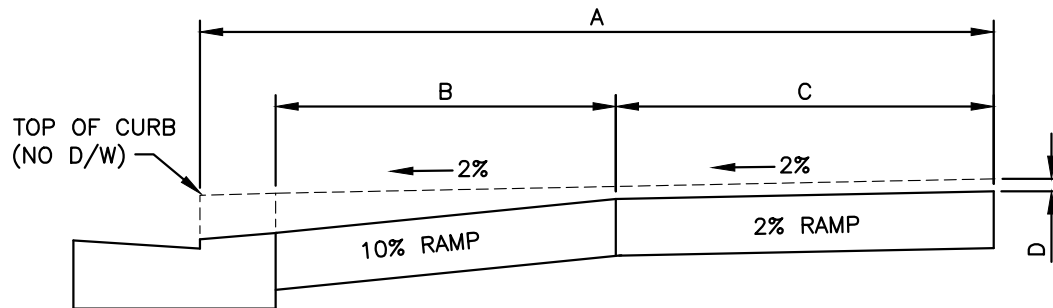

HALIFAX

STANDARD DETAIL
**CONCRETE SIDEWALK
 ADJACENT CURB**

DATE:	2021	REFERENCE	APPROVED
SCALE:	AS NOTED		FIG No.: HRM 133

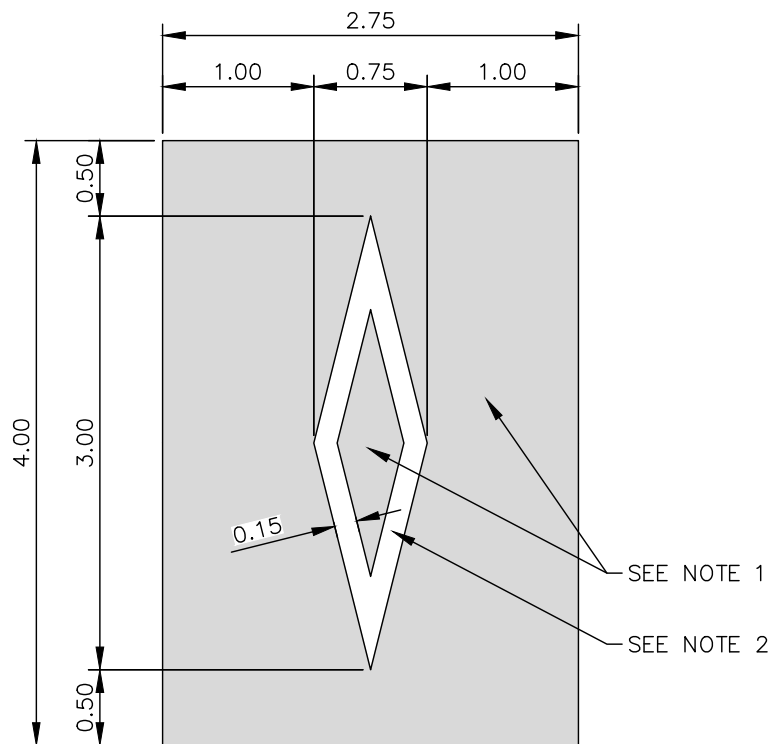

NOTE:

1. PERMANENT PAVEMENT MARKING FOR IN-LAY SHALL BE RED.
2. PERMANENT PAVEMENT MARKING FOR RESERVED LANE SYMBOL SHALL BE WHITE.
3. DIMENSIONS ARE IN METRES.

HALIFAX		
STANDARD DETAIL		
RED IN-LAY RESERVED LANE		
DATE:	2021	REFERENCE
SCALE:	1:50	APPROVED
		FIG. NO. HRM 134

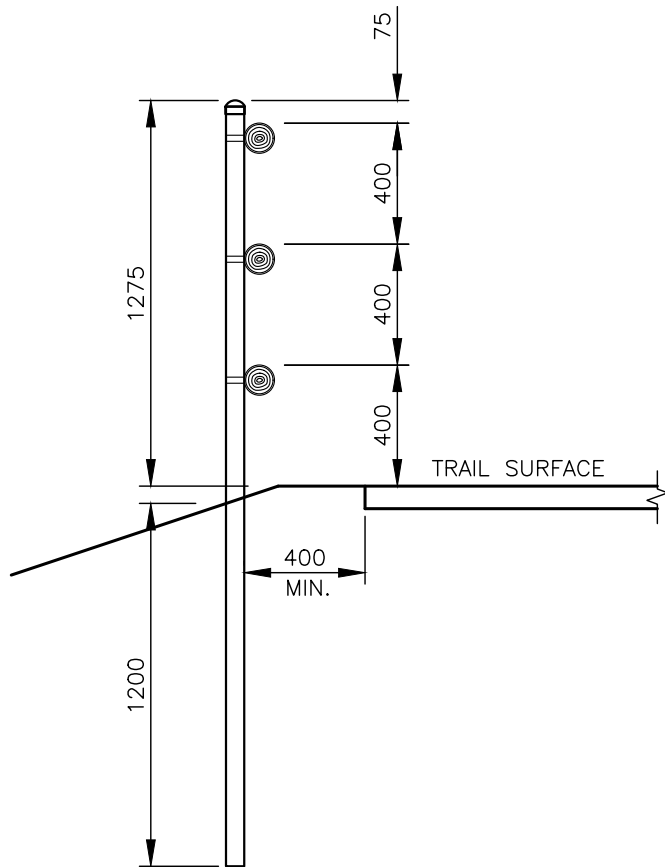

FENCE SECTION

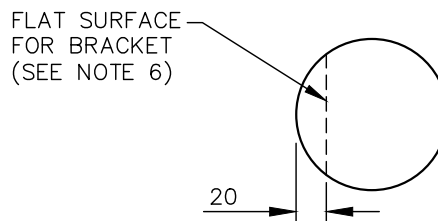

WOODEN RAIL SECTION AT POST

NOTES:

1. POSTS 60 mm O.D. HOT DIPPED GALVANIZED COLD ROLLED STEEL (ASTM A53 GRADE A, SCHEDULE 40), ZINC-COATED AT MINIMUM 550 G/SM.
2. UNLESS OTHERWISE APPROVED BY ENGINEER, DRILL POST HOLES WITH 125 mm MAXIMUM DIAMETER BIT. STABILIZE GROUND AROUND POSTS WITH CEMENT GROUT AND MECHANICAL COMPACTOR.
3. THERE SHALL BE NO EXPOSED (NON-GALVANIZED) STEEL, EXCEPT THE TOP OF THE POSTS (PRIOR TO PLACEMENT OF CAPS).
4. POST SPACING OF 2.4 m EXCEPT LESS ON TIGHT TURNS TO MAINTAIN TRAIL WIDTH.
5. GALVANIZED STEEL CAPS TO BE SET SECURELY OVER TOP OF POSTS (WELDING NOT PERMITTED).
6. RAILS 95-115 mm DIAMETER SMOOTH UNTREATED HEMLOCK WOOD (NO CHECKS, SPLITS OR WIND SHAKES). OUTSIDE EDGES OF ABUTTING ENDS OF RAILS SHALL BE FLUSH (WITHIN 5 mm). PROVIDE FLAT SURFACE FOR FASTENERS 20 mm FROM BACK OF RAILS WHICH CAN BE THE FULL LENGTH OF THE RAILS.
7. ENDS OF RAILS SHALL LINE UP WITH CENTRE OF POSTS EXCEPT AT END POSTS WHERE THE RAILS SHALL EXTEND 100 mm PAST THE CENTRE OF POSTS.
8. PRE-DRILL WOODEN RAILS FOR OZCO JAWS 60 mm GALVANIZED STEEL BRACKETS (OZCO ITEM #51824, 24 PACK)
9. BEND FLANGES OF BRACKETS TO ANGLE REQUIRED WHEN FENCE IN ON A HORIZONTAL CURVE.
10. MATERIALS AND CONSTRUCTION SHALL BE IN ACCORDANCE WITH THE LATEST REVISIONS OF THE NOVA SCOTIA BUILDING CODE REGULATIONS AND THE NATIONAL BUILDING CODE OF CANADA.
11. DIMENSIONS ARE IN MILLIMETRES.

HALIFAX		
STANDARD DETAIL		
FENCE DETAIL (ROUND WOODEN RAILS & STEEL POSTS)		
DATE:	2021	REFERENCE
SCALE:	NTS	APPROVED
		FIG. NO. HRM 135

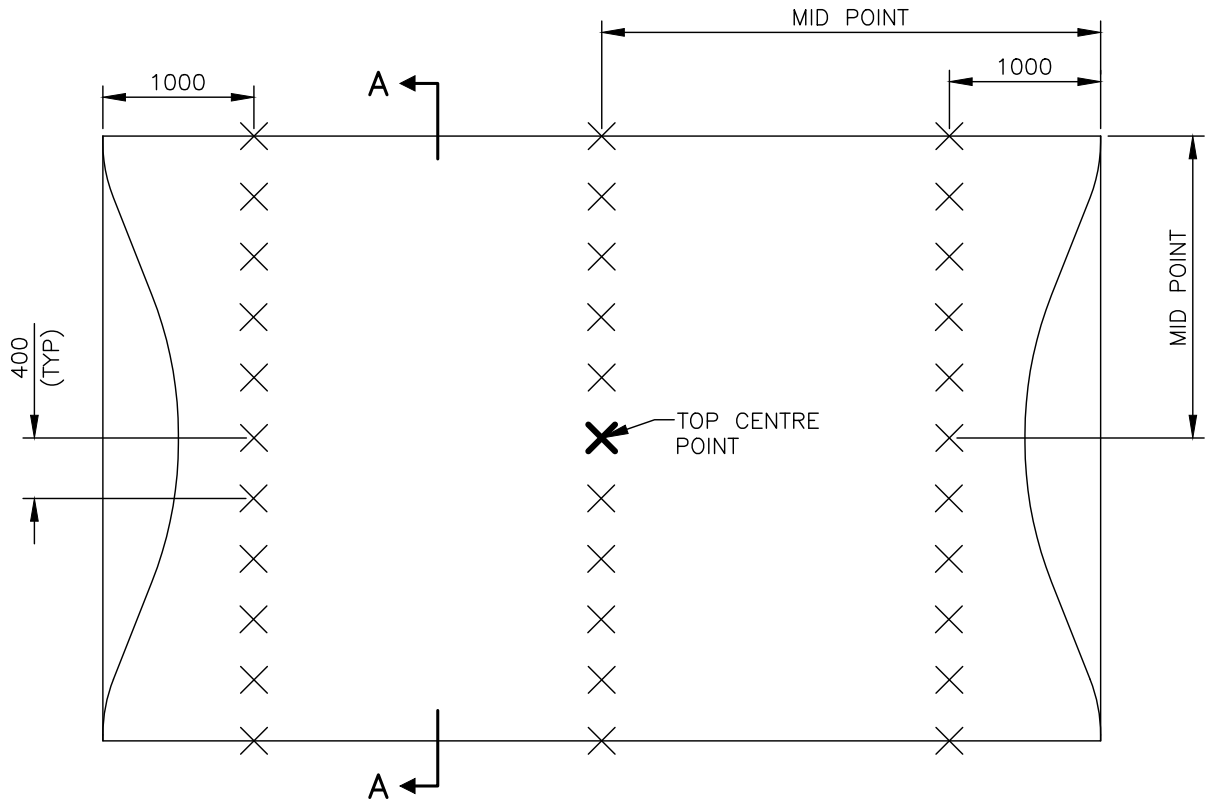

SPEED HUMP

SCALE: 1:50

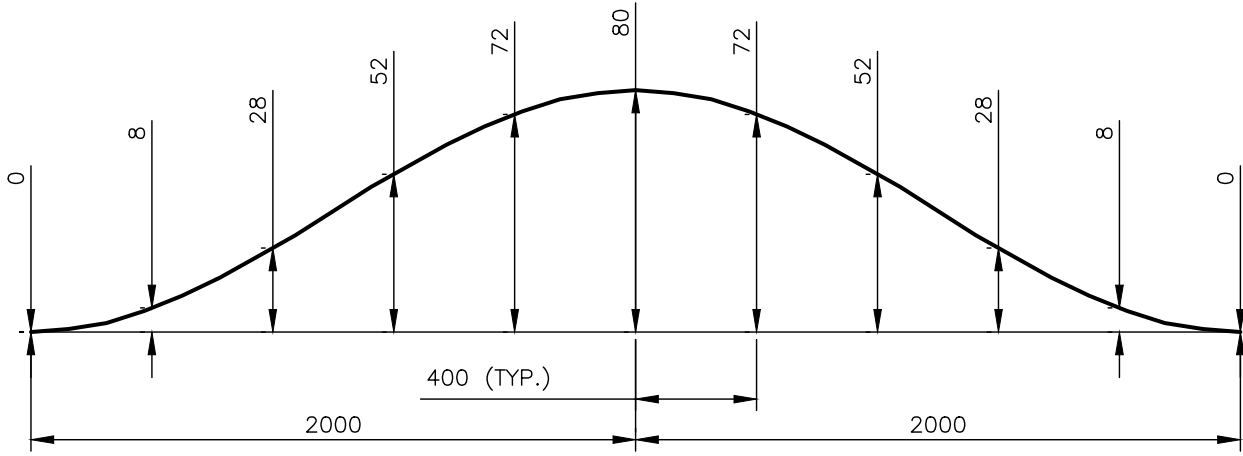

SECTION A-A

SCALE: Horz. 1:25
Vert. 1:2.5

NOTES:

1. 33 SURVEY SHOTS ELEVATION REQUIRED.
2. COORDINATES REQUIRED AT THE TOP CENTRE OF THE SPEED HUMP.
3. DIMENSIONS ARE IN MILLIMETRES.

TOP CENTRE POINT COORDINATES:
NORTHING:
EASTING:

HALIFAX

STANDARD DETAIL

**SPEED HUMP
SURVEY VERIFICATION**

DATE: 2021	REFERENCE	APPROVED
SCALE: AS NOTED		FIG No.: HRM 136

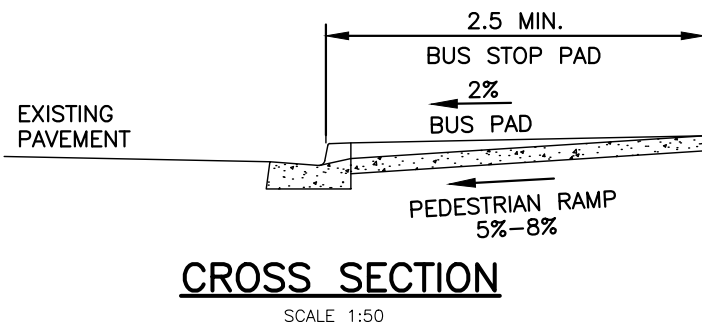
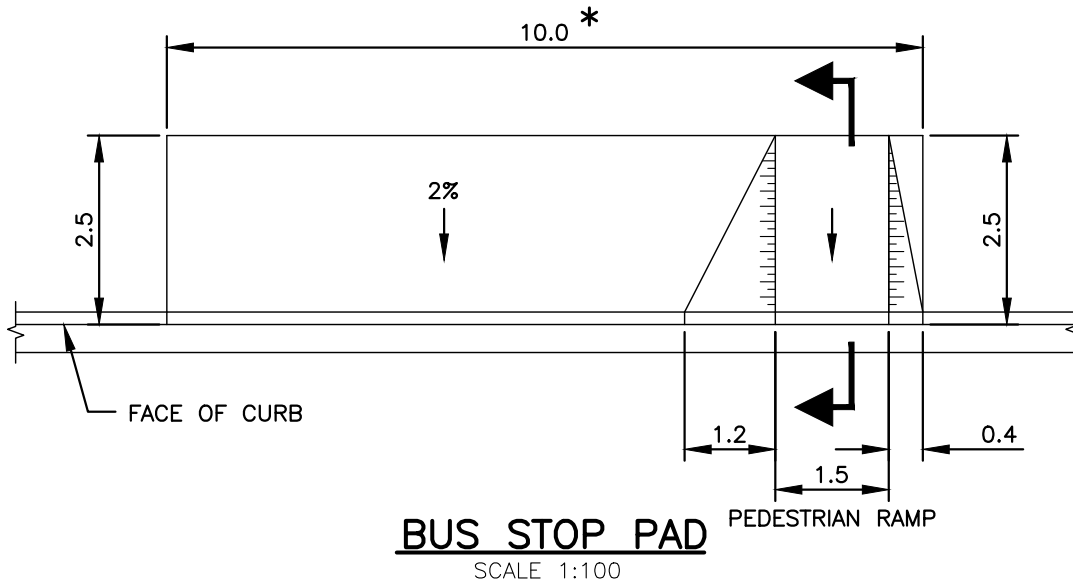
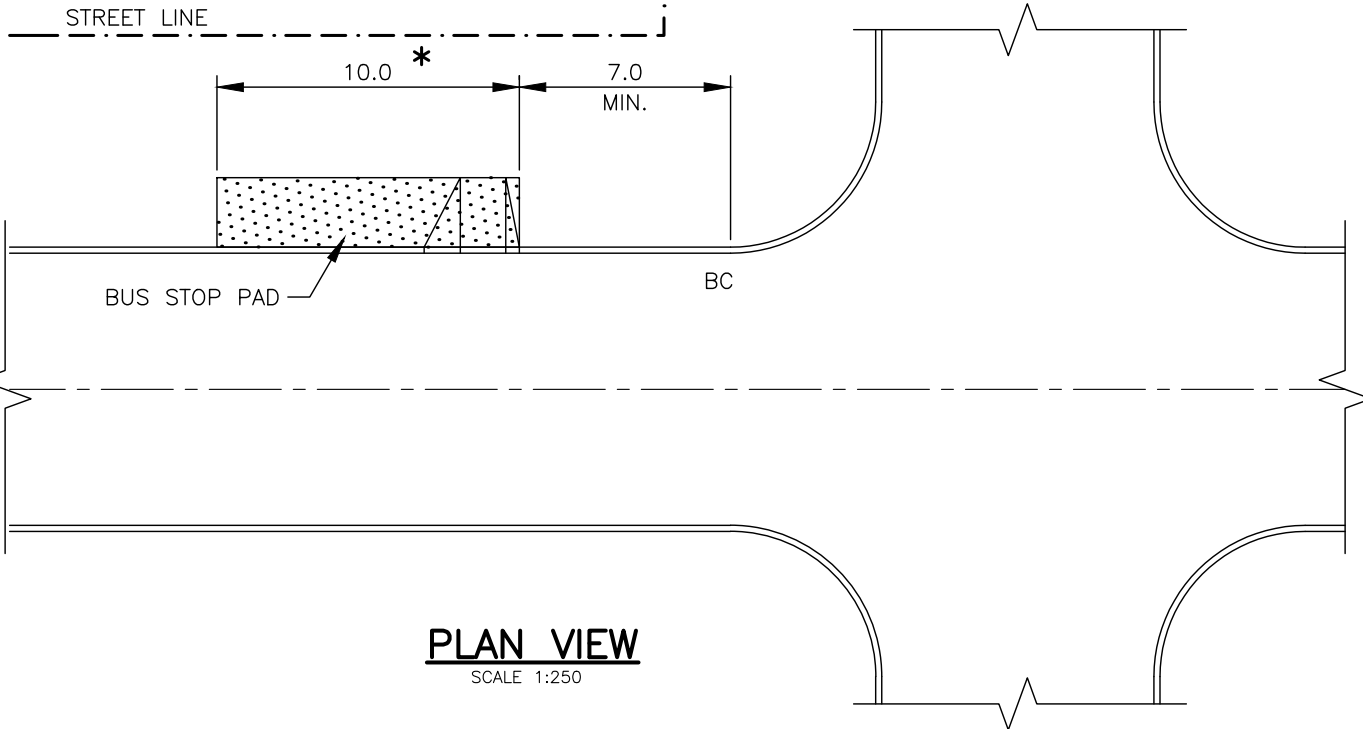

NOTES:

- * 1. FOR LOW VOLUME BUS ROUTES
-DECREASE PAD LENGTH TO 5.0 m.
- * 2. FOR ARTICULATED BUS ROUTES
-INCREASE PAD LENGTH TO 15.5 m.

HALIFAX

STANDARD DETAIL

CONCRETE BUS STOP LANDING PAD (WITHOUT SIDEWALK)

DATE: 2021	REFERENCE	APPROVED
SCALE: AS NOTED		FIG No.: HRM 137

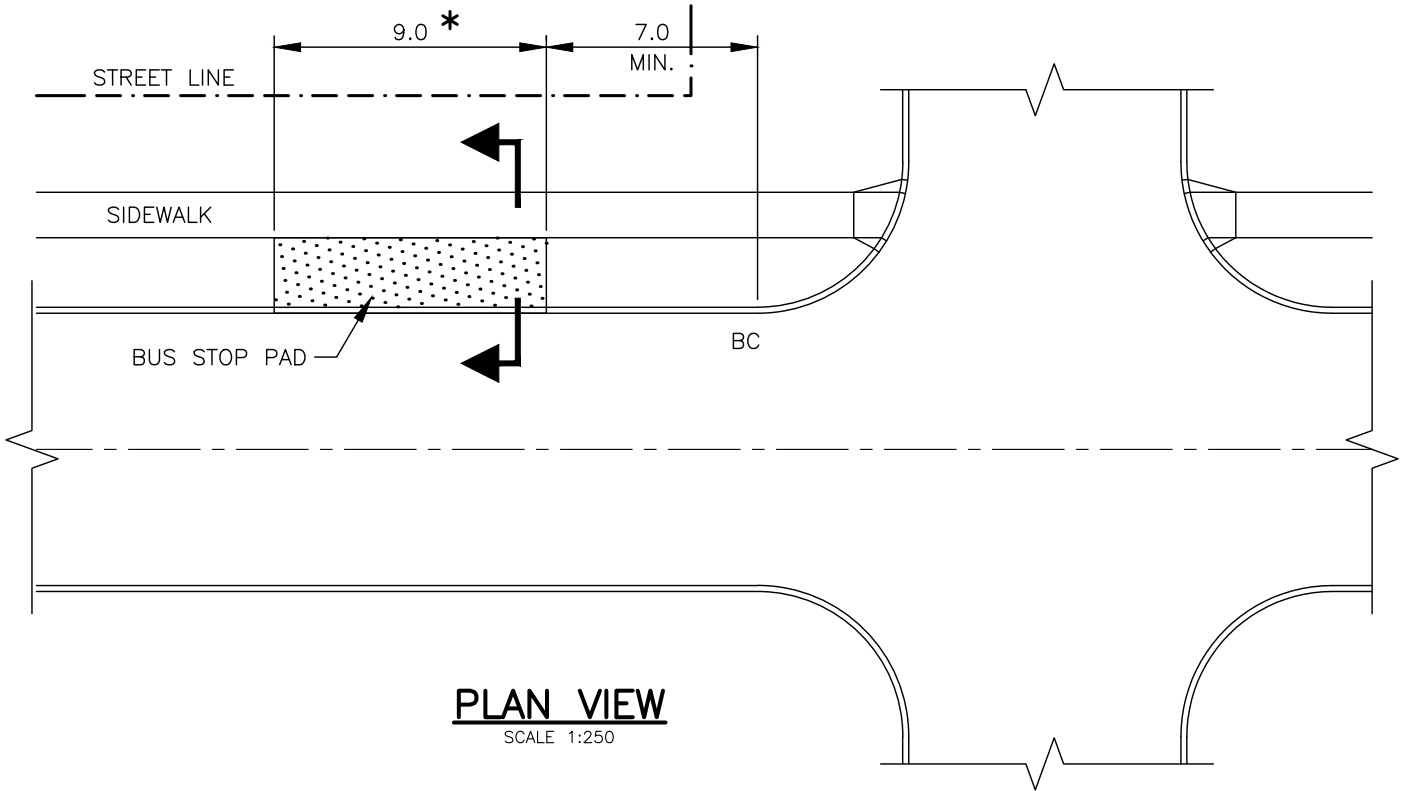

PLAN VIEW

SCALE 1:250

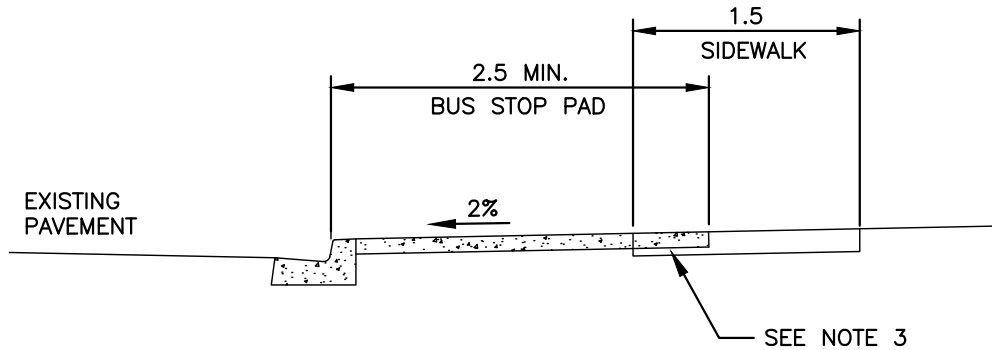

CROSS SECTION

SCALE 1:50

NOTES:

- * 1. FOR LOW VOLUME BUS ROUTES
-DECREASE PAD LENGTH TO 4.0 m.
- * 2. FOR ARTICULATED BUS ROUTES
-INCREASE PAD LENGTH TO 14.5 m.
- 3. THE 2.5 m WIDE BUS STOP LANDING PAD
MAY INCLUDE A PORTION OF THE
SIDEWALK.

HALIFAX

STANDARD DETAIL

**CONCRETE BUS STOP
LANDING PAD (WITH SIDEWALK)**

DATE: 2021	REFERENCE	APPROVED
SCALE: AS NOTED		FIG No.: HRM 138

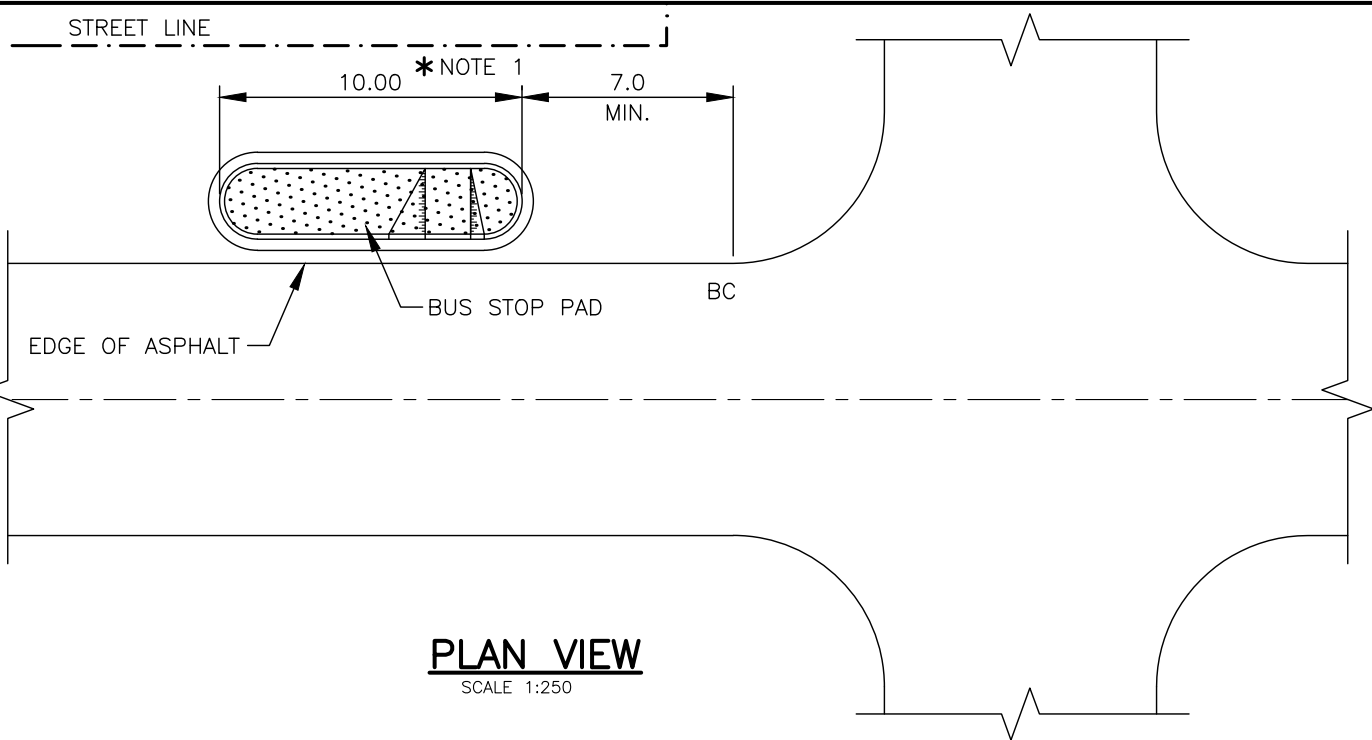

PLAN VIEW

SCALE 1:250

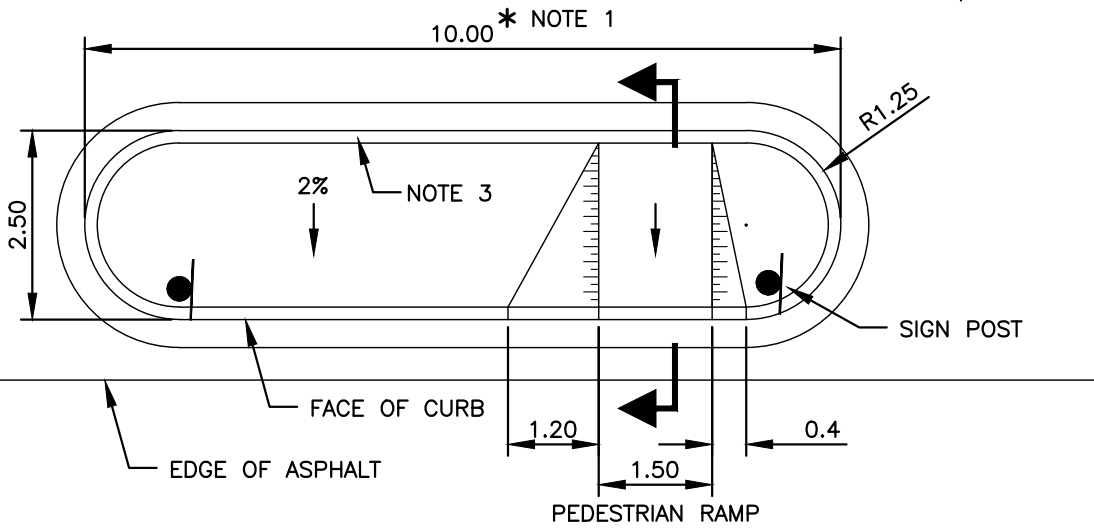

BUS STOP PAD

SCALE 1:100

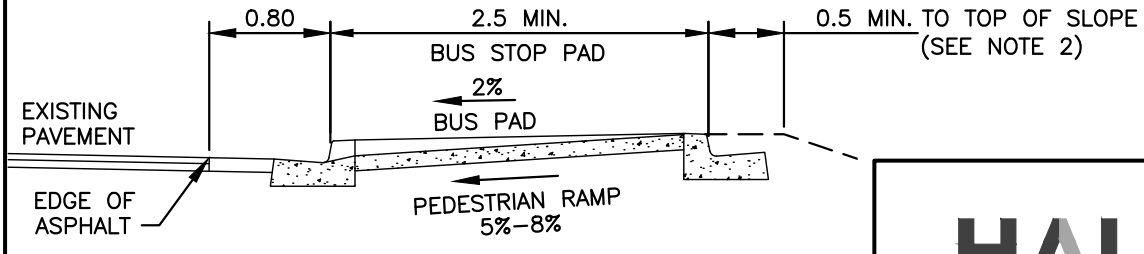

CROSS SECTION

SCALE 1:50

NOTES:

- * 1. FOR LOW VOLUME BUS ROUTES
- DECREASE PAD LENGTH TO 5.0 m MINIMUM.
- 2. BACK SIDE CURB MAY BE REMOVED IN AREAS WITH DITCHES.

HALIFAX

STANDARD DETAIL

CONCRETE BUS STOP LANDING PAD (WITHOUT CURB)

DATE: 2021	REFERENCE	APPROVED
SCALE: AS NOTED		FIG No.: HRM 139

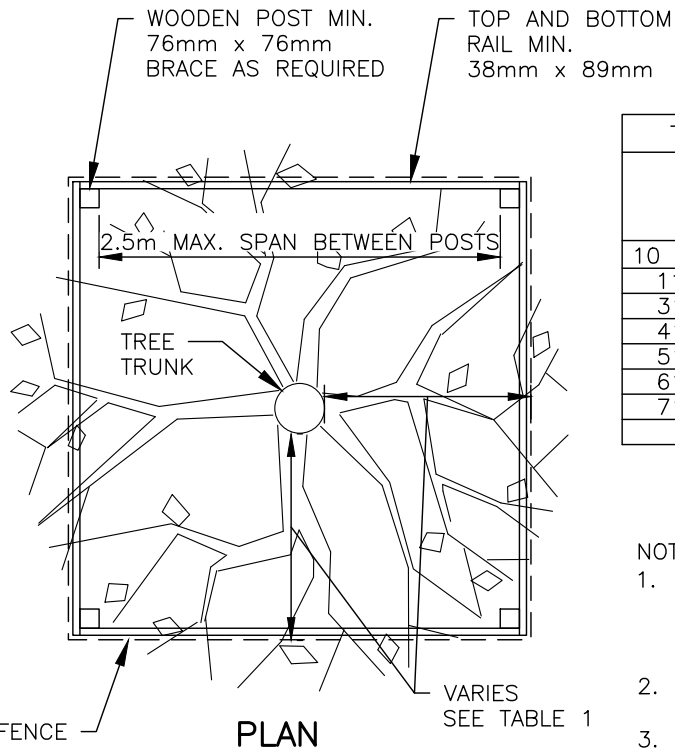

PLAN

TABLE 1

TREE PROTECTION ZONE CALCULATION TABLE

TRUNK DIAMETER (DBH)	MINIMUM PROTECTION DISTANCE REQUIRED (MEASURE FROM THE OUTSIDE EDGE OF TREE TRUNK)
10 CM & UNDER	1.2 METERS
11 – 30 CM	2.0 METERS
31 – 40 CM	3.4 METERS
41 – 50 CM	4.6 METERS
51 – 60 CM	6.0 METERS
61 – 70 CM	7.0 METERS
71 – 80 CM	8.0 METERS
>80 CM	9.0 METERS

NOTES:

1. WOOD POST: (MIN. 76mm WIDTH) INSTALLED TO A DEPTH OF 500mm. TOP AND BOTTOM RAIL: (MIN. 38 x 89mm CONSTRUCTION, MAX. SPAN 2.5m), CROSS BRACING AS REQUIRED.
2. NO GROUND DISTURBANCE WITHIN 1.2 METER OF THE TREE TRUNK (I.E. POST INSTALLATION)
3. POSTS SET BACK FROM SIDEWALK AND CURB: MIN 300mm
4. FENCE MATERIAL: MINIMUM ORANGE BARRIER FENCE OR METAL CHAIN LINK FENCE
5. ATTACH A SIGN ON TWO SIDES OF THE TREE "PROTECTION ZONE DO NOT REMOVE FENCE DURING CONSTRUCTION"

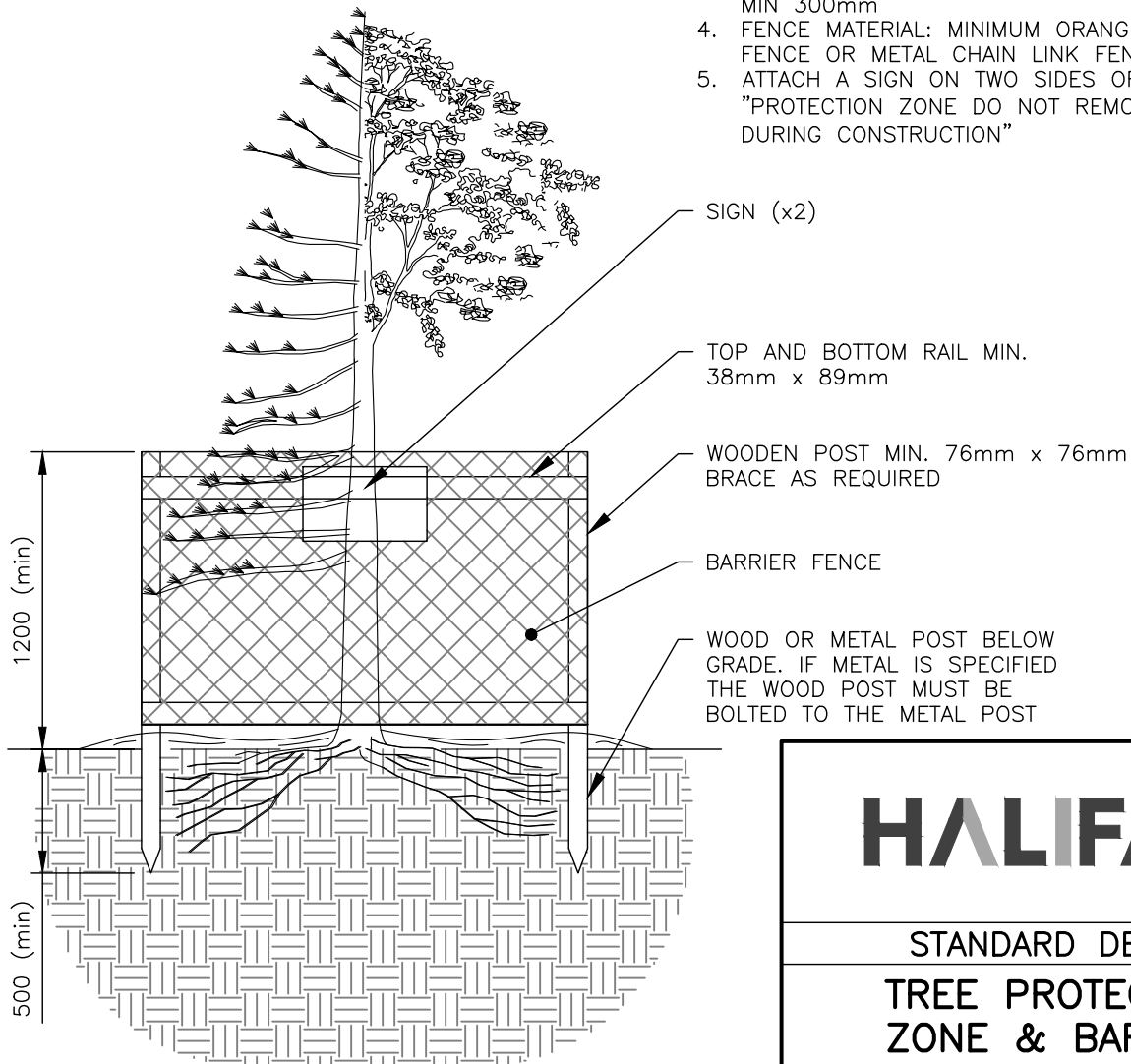

PROFILE

HALIFAX

STANDARD DETAIL

TREE PROTECTION ZONE & BARRIER

DATE:	REFERENCE	APPROVED
2021		
SCALE:		FIG No.:
NTS		HRM 140

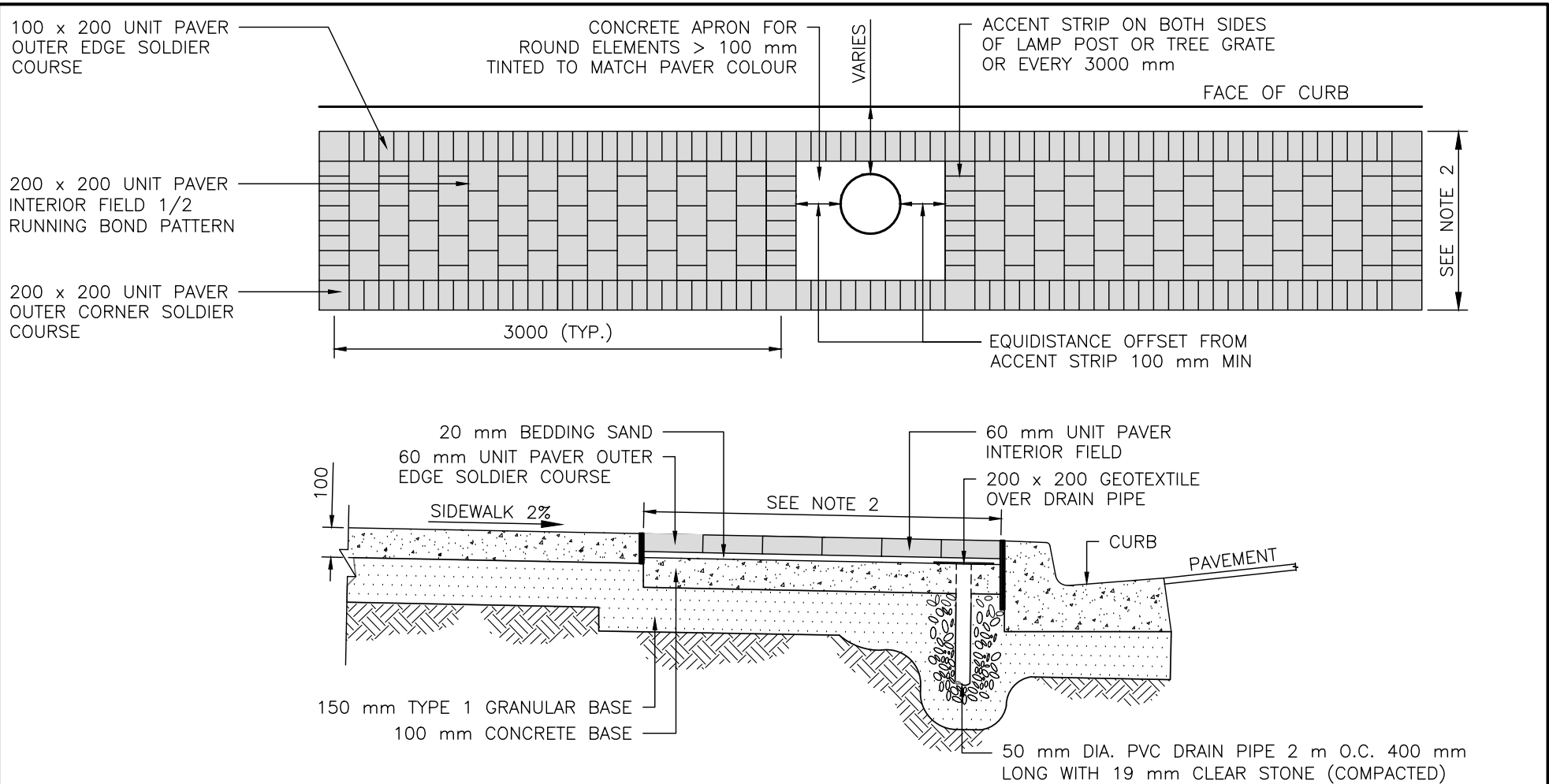

NOTES:

1. INSTALL DECORATIVE PAVING EDGE IN LIEU OF GRASS BOULEVARD WHERE SHOWN ON MAP 301, OR AS DIRECTED BY ENGINEER
2. PAVER EDGE SHALL NOT REDUCE THE CLEAR SIDEWALK WIDTH TO LESS THAN 2.1m AND SHALL CONSIST OF AN EVEN MULTIPLE OF UNIT PAVERS TO A MAXIMUM OF 1.2 m WIDE.
3. OMIT PAVER EDGE IF SIDEWALK IS LESS THAN 2.8 m WIDE, UNLESS OTHERWISE DIRECTED BY ENGINEER
4. PAVER COLOUR DEFINED ON MAP 301 OR AS DIRECTED BY ENGINEER.
5. TERMINATE UNIT PAVER EDGE TREATMENT AT START OF CORNER RADIUS AND BEFORE DRIVEWAY RAMP
6. ALL PAVERS TO BE PRECAST CONCRETE 60mm THICK.
7. SET PAVERS 2-3 mm ABOVE SURROUNDING CONCRETE SURFACES TO ACCOMMODATE FUTURE SETTLEMENT
8. STREET FURNITURE LOCATIONS MUST BE APPROVED BY ENGINEER (E.G. BICYCLE RACKS, BENCHES, WASTE RECEPTACLES, ETC.), AND BOLTED TO CONCRETE BELOW PAVERS.
9. FILL VOID BETWEEN PAVERS WITH POLYMERIC SAND.
10. CONCRETE APRON REQUIRED FOR ROUND ELEMENTS >100mm DIAMETER (E.G. UTILITY POLES, LIGHT POLES, MANHOLE COVERS, VALVE COVERS, ETC) TINTED TO MATCH INTERIOR FIELD PAVER COLOUR
11. FOR ROUND ELEMENTS < 100MM DIAMETER OMIT CONCRETE APRON.

HALIFAX

STANDARD DETAIL

DECORATIVE PAVING EDGE

DATE: 2021	REFERENCE	APPROVED
SCALE: NTS		FIG No.: HRM 141

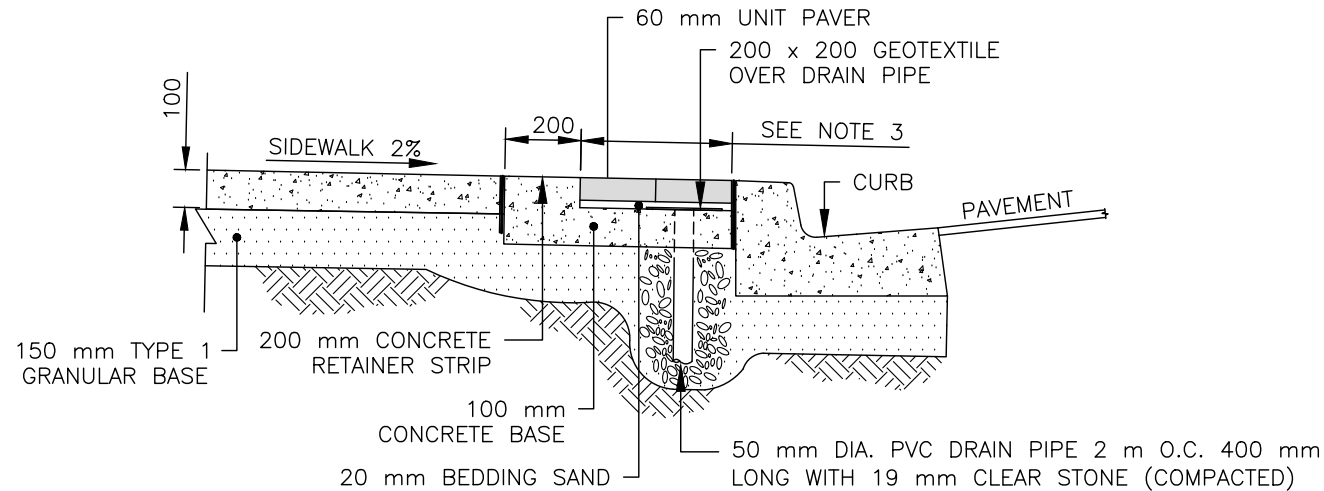
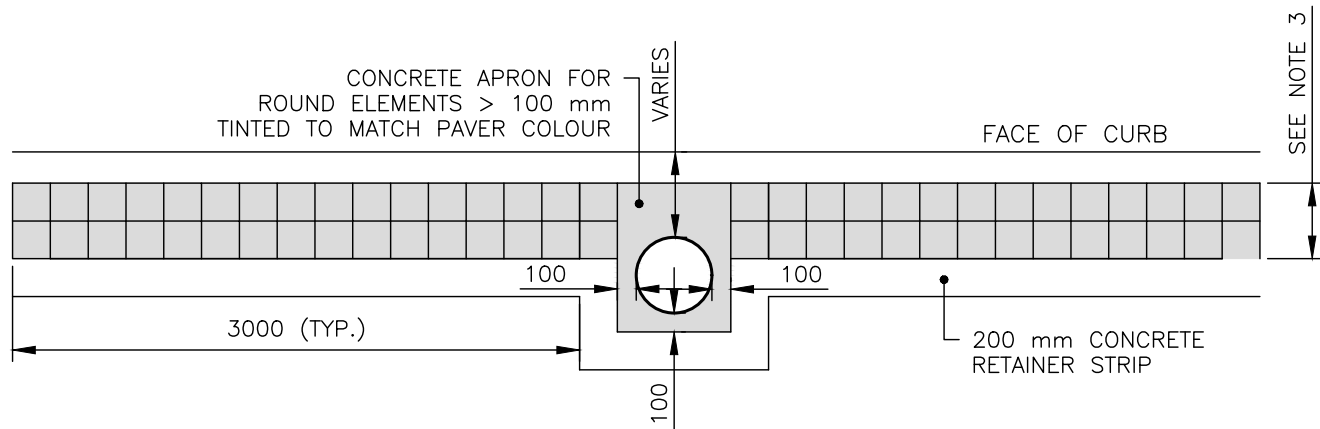

NOTES:

1. INSTALL DECORATIVE PAVING EDGE IN LIEU OF GRASS BOULEVARD WHERE SHOWN ON MAP 301, OR WHEN DIRECTED BY ENGINEER
2. OMIT PAVER EDGE IF CLEAR WIDTH OF REMAINING SIDEWALK IS LESS THAN 2.1m, UNLESS OTHERWISE DIRECTED BY ENGINEER
3. PAVER EDGE SHALL CONSIST OF 2 COMPLETE ROWS OF BRICKS IN A STACK BOND PATTERN. NO CUT PAVERS.
4. PAVER COLOUR DEFINED ON MAP 301 OR AS DIRECTED BY ENGINEER
5. TERMINATE UNIT PAVER EDGE TREATMENT AT START OF CORNER RADIUS AND BEFORE DRIVEWAY RAMP
6. ALL PAVERS TO BE PRECAST CONCRETE 60mm THICK
7. SET PAVERS 2-3 mm ABOVE SURROUNDING CONCRETE SURFACES TO ACCOMMODATE FUTURE SETTLEMENT
8. STREET FURNITURE LOCATIONS MUST BE APPROVED BY ENGINEER (E.G. BICYCLE RACKS, BENCHES, WASTE RECEPTACLES, ETC.), AND BOLTED TO CONCRETE RETAINER STRIP OR TO CONCRETE BELOW PAVERS
9. FILL VOID BETWEEN PAVERS WITH POLYMERIC SAND
10. CONCRETE APRON REQUIRED FOR ROUND ELEMENTS >100mm DIAMETER (E.G. UTILITY POLES, LIGHT POLES, MANHOLE COVERS, VALVE COVERS, ETC) TINTED TO MATCH INTERIOR FIELD PAVER COLOUR
11. OFFSET CONCRETE APRON MINIMUM 100mm
12. FOR ROUND ELEMENTS < 100 mm DIAMETER OMIT CONCRETE APRON

HALIFAX

STANDARD DETAIL

NARROW DECORATIVE PAVING EDGE

DATE: 2021	REFERENCE	APPROVED
SCALE: NTS		FIG No.: HRM 142

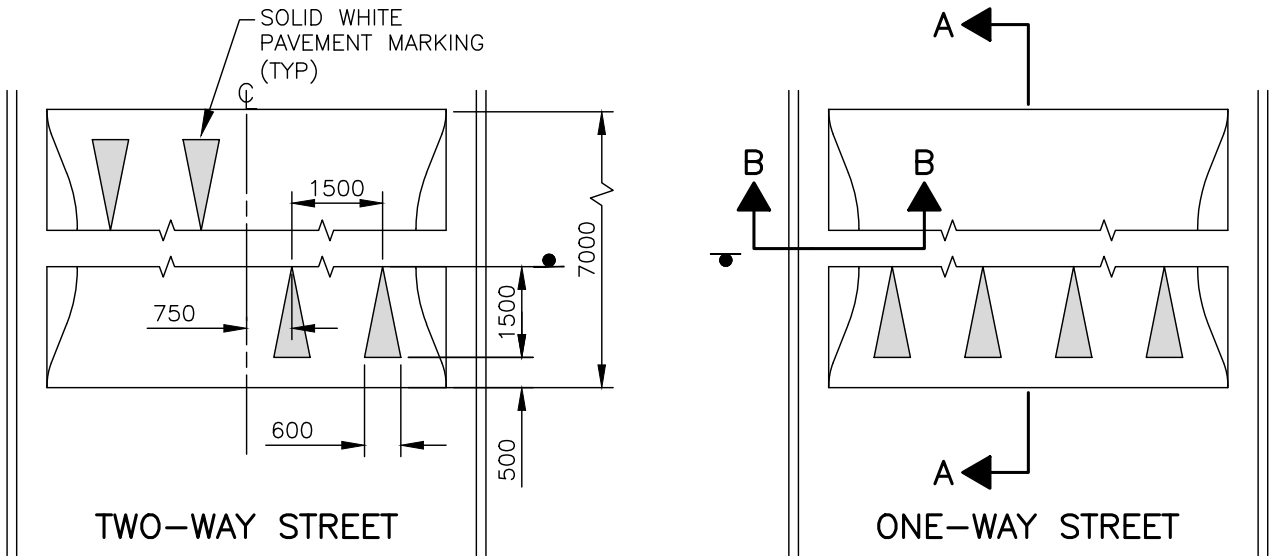

SPEED TABLE

SCALE: 1:125

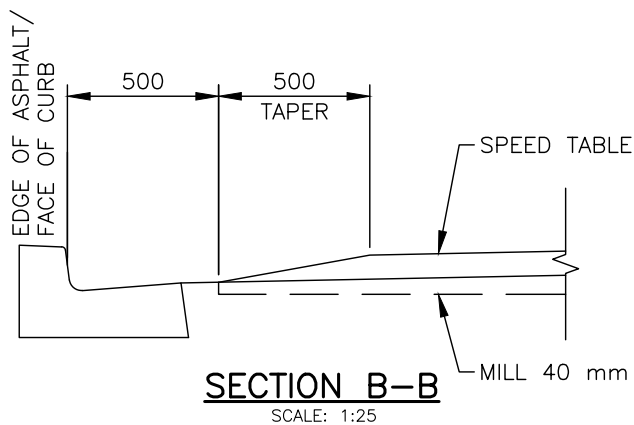
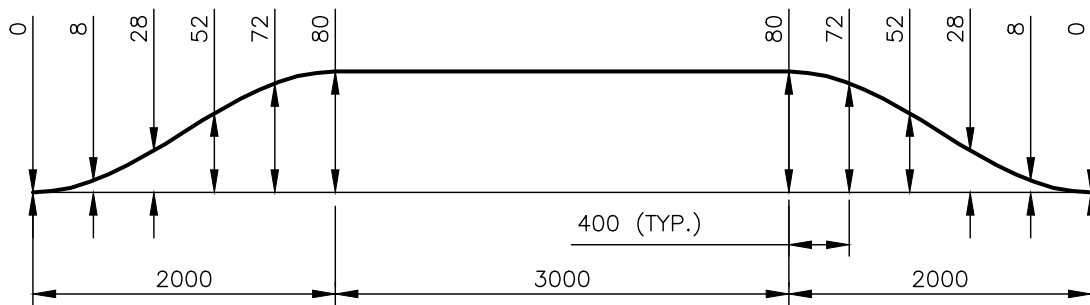

NOTES:

1. TOLERANCE FOR CONSTRUCTION IS +/- 10 mm RELATIVE TO THE CURVE.
2. THE EXISTING ASPHALT SURFACE TO BE MILLED TO A DEPTH OF 40 mm WHEN RETROFITTING.
3. DIMENSIONS ARE IN MILLIMETRES.

HALIFAX		
STANDARD DETAIL		
SPEED TABLE DETAIL		
DATE: 2021	REFERENCE	APPROVED
SCALE: AS NOTED		FIG No.: HRM 143

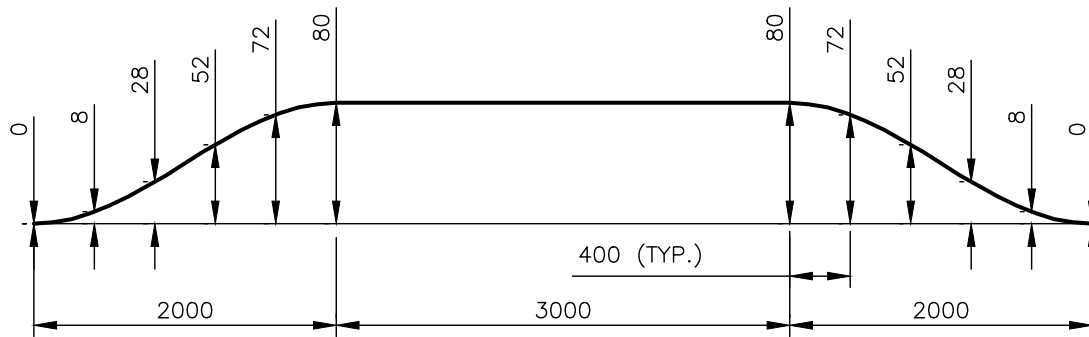
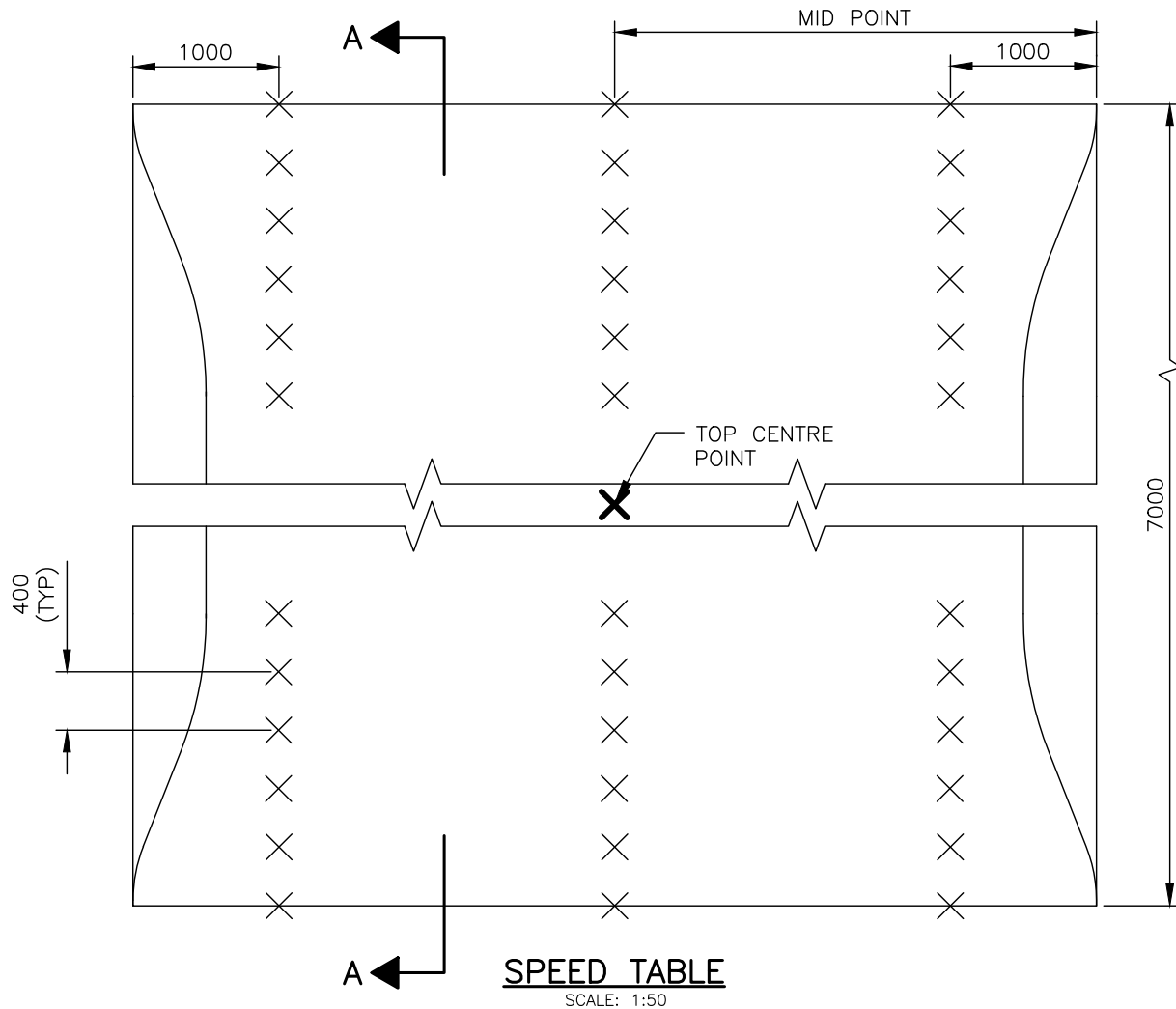

NOTES:

1. 36 SURVEY SHOTS ELEVATION REQUIRED.
2. COORDINATES REQUIRED AT THE TOP CENTRE OF THE SPEED TABLE.
3. DIMENSIONS ARE IN MILLIMETRES.

<u>TOP CENTRE POINT COORDINATES:</u>	
NORTHING:	EASTING:

HALIFAX

STANDARD DETAIL

**SPEED TABLE
SURVEY VERIFICATION**

DATE: 2021	REFERENCE	APPROVED
SCALE: AS NOTED		FIG No.: HRM 144

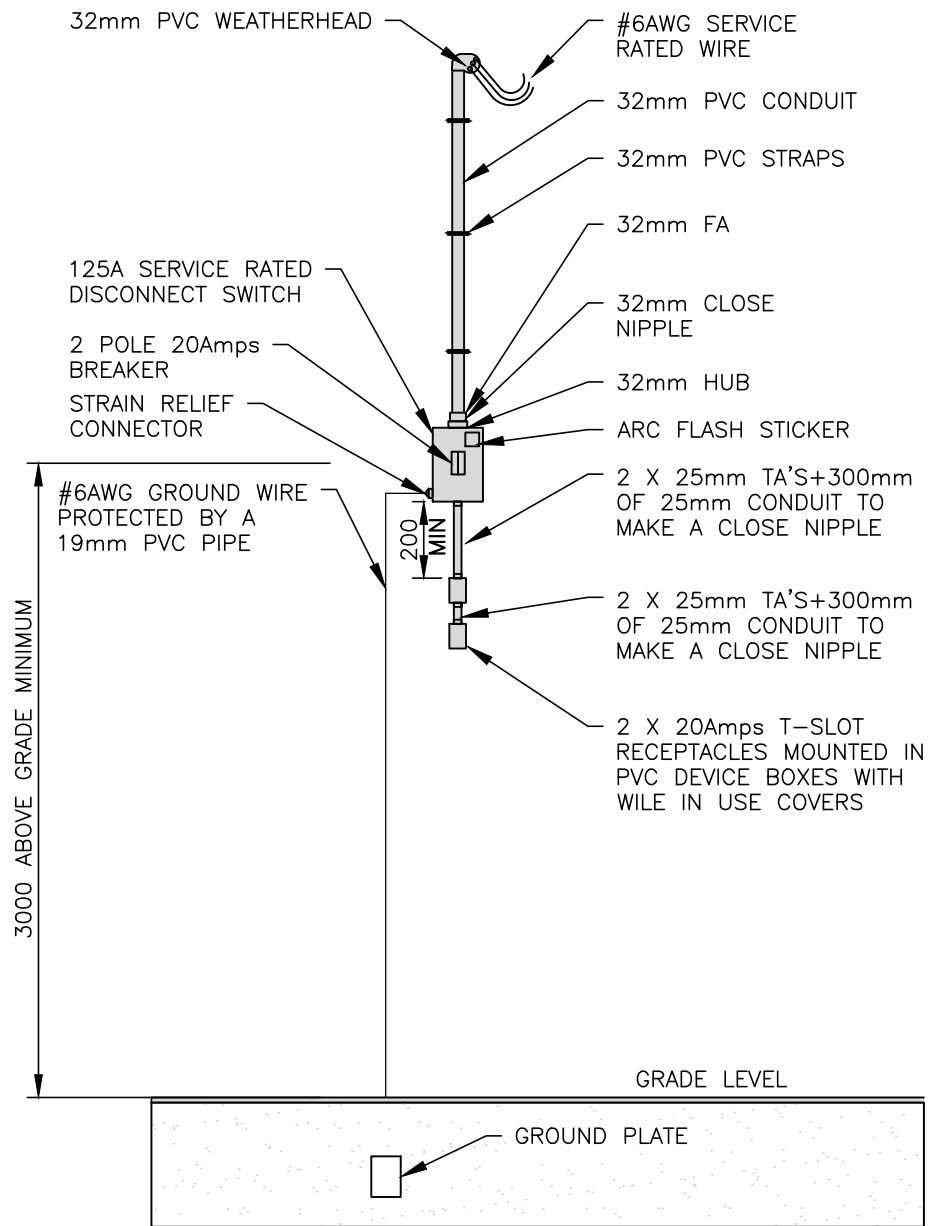

NOTES:

1. BREAKER MUST BE A DOUBLE POLE, NO SPARE SERVICE WIRES ARE ALLOWED.
2. DO NOT INSTALL PHOTOEYES IN POLES FED OFF OF THIS SERVICE.
3. ALL WORK MUST BE IN COMPLIANCE WITH THE LATEST EDITION OF THE CANADIAN ELECTRICAL CODE AND INSPECTED BY NSPI.
4. UNDERGROUND SERVICE CONDUIT AND GROUND MUST BE PROTECTED BY A U-GUARD AND BONDED AS PER CEC.
5. ALL SCREWS IN THE SERVICE SWITCH ARE TO BE NEVER SEIZED, AND MOUNTING SCREWS ARE TO BE STAINLESS STEEL ONLY.
6. IF THERE IS MORE THAN ONE CIRCUIT OR IF THE CIRCUIT DRAWS MORE THAN 15Amps A CONTACTOR IS REQUIRED. REFER TO UNDERGROUND STANDARDS.
7. SERVICE MUST ALWAYS BE CONNECTED TO THE SECONDARIES NEVER THE CONTROL LINE.
8. MINIMUM WIRE SIZE IS #6AWG.

<h1>HALIFAX</h1>		
STANDARD DETAIL		
240 VOLT UNDER 20Amps SERVICE WITH GFCI		
DATE:	REFERENCE	APPROVED
2021		
SCALE:		FIG No.:
NTS		HRM 145

SQUARE D ENCLOSED BREAKER AND ACCESSORIES OR EQUIVALENT HDL26040
 2 POLE BREAKER C/W NEMA STYLE OPERATING MECHANISM 9421LS8 SHAFT AND 9421LJ7 MECHANISM
 40A 240V
 SN100FA 100A NEUTRAL KIT
 FA 100 RB EEMAC 3R ENCLOSURE
 B125 32mm HUB
 PKOGTA2 GROUND LUGS

BULLET HUB THOMAS AND BETTS 373

HOLE TO BE ALIGNED WITH HOLE IN DISCONNECT

ENCLOSED BREAKER

GROUND LUG

15Amp BREAKER (BUS SHELTER)

#12 TERMINALS
 TERMINAL BLOCKS
 -8WA10111DH
 END STOPS
 -8WA1808

END STOPS

SPACER

PHOTO CELL
 LB 201

32 mm TERMINAL ADAPTER PVC

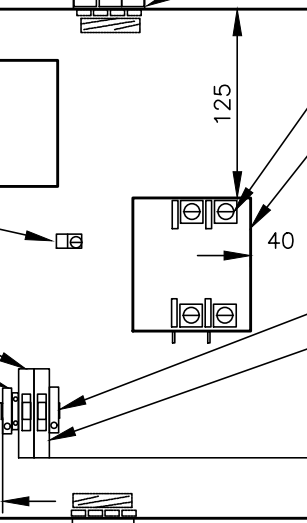

DETAIL-A

CONTACTOR

FURNAS 42CF25AF (LITECO)
 CONTACTOR-2 POLE 40A

RELAY ENCLOSURE NEMA 4X RATED- SHALL BE PART No.SM141007 C/W POLICE TYPE LOCK, AS SUPPLIED BY APX ENCLOSURES, OR EQUIVALENT.

MOUNTING RAIL

6Amp BREAKER USED FOR PHOTO CELL BYPASS BREAKER-5SY61088 (LITECO)

ONCE BUILT, RELAYS CAN BE APPROVED BY CALLING QPS FIELD EVALUATION SERVICES

(902) 860-1619

(902) 452-5942

OR

CSA INTERNATIONAL

(506) 388-3600

(506) 856-0058

ALL RELAYS SHOULD BE TESTED AT THE SAME TIME. IF LOW BIDDER IS A CERTIFIED PANEL SHOP, THEN APPROVAL FROM OUTSIDE

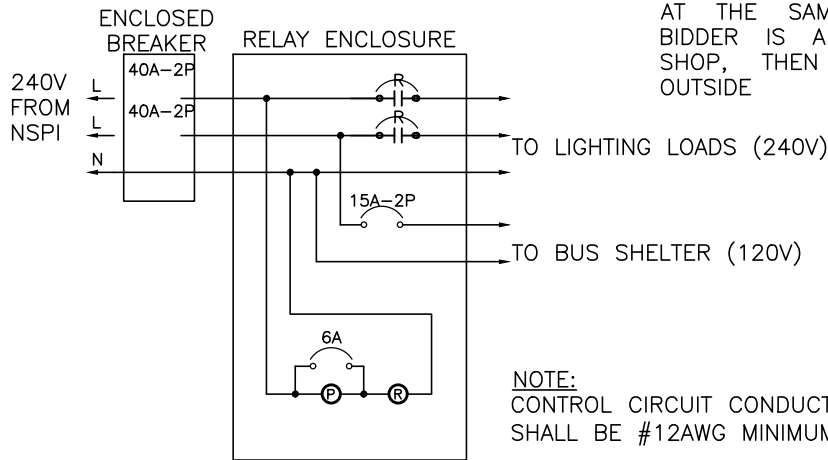

NOTE:
 CONTROL CIRCUIT CONDUCTORS SHALL BE #12AWG MINIMUM

SERVICE SCHEMATIC

NOTES:

1. BREAKER MUST BE A DOUBLE POLE, NO SPARE SERVICE WIRES ARE ALLOWED.
2. CIRCUITS RATED AT MORE THAN 15Amps REQUIRE A CONTACTOR.
3. ALL WORK MUST BE IN COMPLIANCE WITH THE LATEST EDITION OF THE CANADIAN ELECTRICAL CODE AND INSPECTED BY NSPI.
4. UNDERGROUND SERVICE CONDUIT AND GROUND MUST BE PROTECTED BY A U-GUARD AND BONDED AS PER CEC.
5. ALL SCREWS IN THE SERVICE SWITCH ARE TO BE NEVER SEIZED, AND MOUNTING SCREWS ARE TO BE STAINLESS STEEL ONLY.

HALIFAX

STANDARD DETAIL

SERVICE CONTACTOR AND SCHEMATIC

DATE:	2021	REFERENCE	APPROVED
SCALE:	NTS	FIG No.:	HRM 146

WIRE #12/2 NMWU
AWG 600mm IN
LENGTH PAST END OF
POLE, TAPED TO TOP
OF POLE SO AS NOT
TO COME LOOSE AND
FALL BACK DOWN.

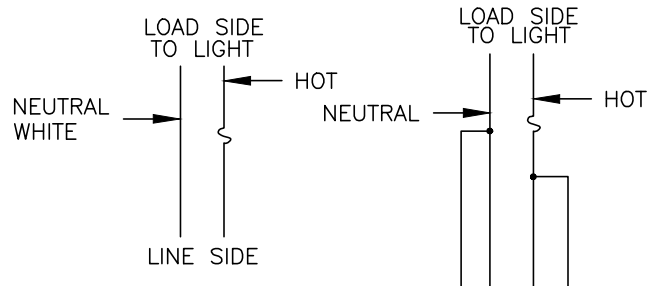

THIS DIAGRAM TO BE USED
IF CIRCUIT CONTINUES TO
ANOTHER POLE

T&B AMERACE CAT#65U BREAK-AWAY FUSE
KIT USE 5Amp TIME DELAY BUSS FUSE

FUSE KIT ON LINE SIDE
PIGTAIL TO FUSE IF CIRCUIT
CONTINUES

NEUTRALS SHALL BE
JOINED USING MARRETTS
OR ILSCO PBTS4-4 AND
COVER WITH VINYL TAPE

GROUND WIRE SHALL BE
TIGHTENED IN TERMINAL
LUG WHICH IN TURN IS
FASTENED TO GROUND BAR
IN POLE. SEE GROUND
CONNECTION DETAIL ON
THIS DRAWING

WIRES COMING DOWN POLE
AND UP FROM CONDUIT
SHOULD BE 1m IN LENGTH
WHEN PULLED THROUGH
ACCESS HOLE

PIGTAILS SHALL BE MADE WITH
SPLIT BOLTS, COVERED WITH
RUBBER COMPOUND TAPE (3m
130C) & VINYL TAPE (3m 88)
OR EQUIVALENT

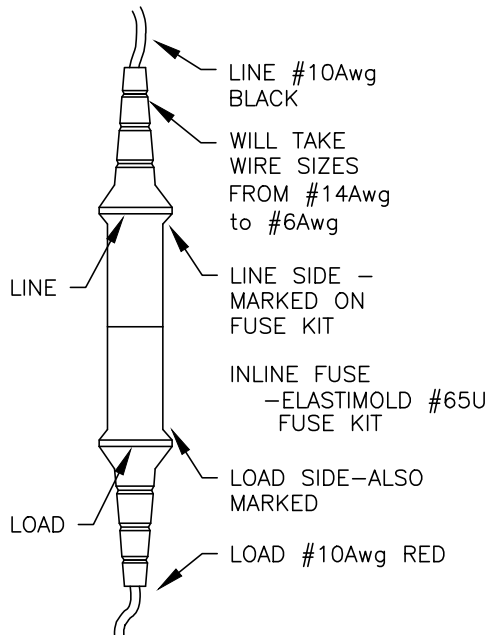

FUSE DETAIL

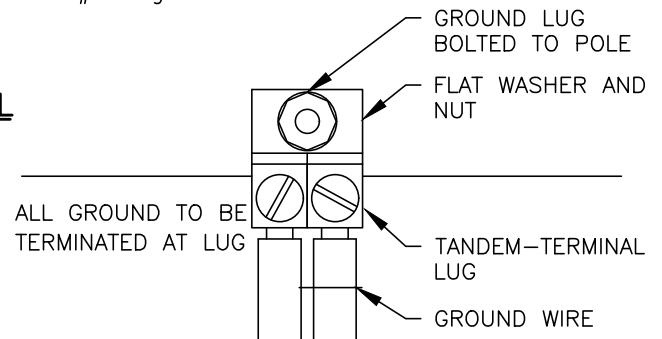

GROUND CONNECTION DETAIL

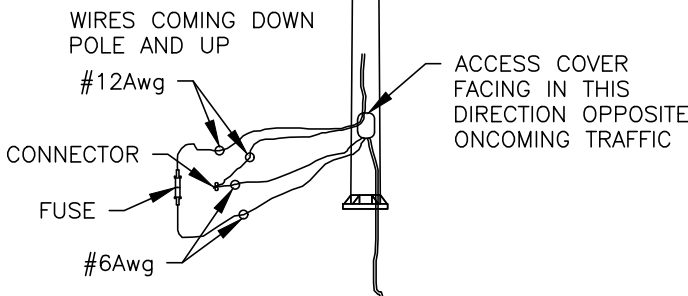

NOTES:

1. BREAKER MUST BE A DOUBLE POLE, NO SPARE SERVICE WIRES ARE ALLOWED.
2. CIRCUITS RATED AT MORE THAN 15Amps REQUIRE A CONTACTOR.
3. ALL WORK MUST BE IN COMPLIANCE WITH THE LATEST EDITION OF THE CANADIAN ELECTRICAL CODE AND INSPECTED BY NSPI.
4. UNDERGROUND SERVICE CONDUIT AND GROUND MUST BE PROTECTED BY A U-GUARD AND BONDED AS PER CEC.
5. ALL SCREWS IN THE SERVICE SWITCH ARE TO BE NEVER SEIZED, AND MOUNTING SCREWS ARE TO BE STAINLESS STEEL ONLY.

HALIFAX

STANDARD DETAIL

POLE ELECTRICAL
DETAILS

DATE:	2021	REFERENCE	APPROVED
SCALE:	NTS		FIG No.: HRM 147

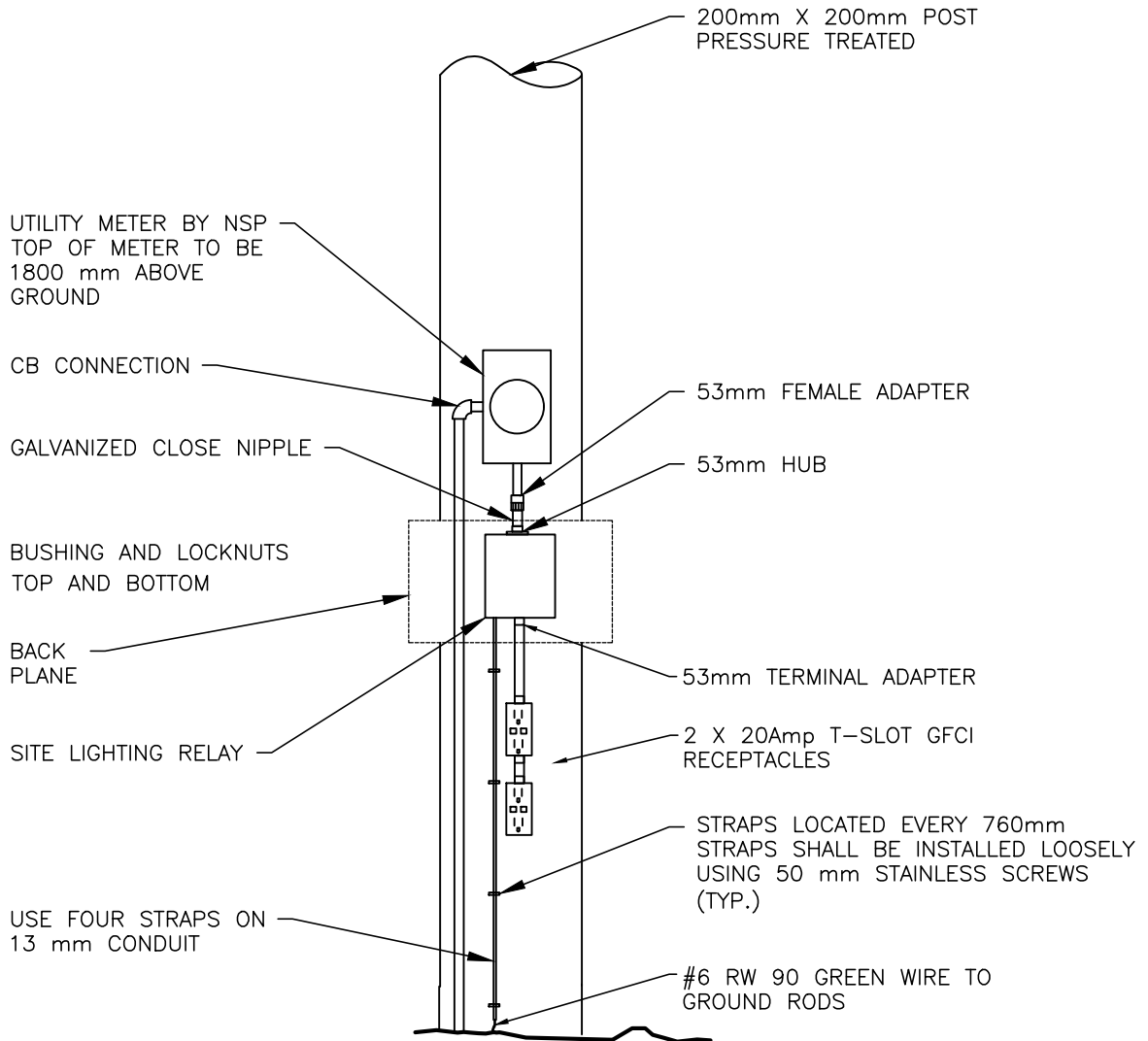

NOTES:

1. BREAKER MUST BE A DOUBLE POLE, NO SPARE SERVICE WIRES ARE ALLOWED.
2. CIRCUITS RATED AT MORE THAN 15Amps REQUIRE A CONTACTOR.
3. ALL WORK MUST BE IN COMPLIANCE WITH THE LATEST EDITION OF THE CANADIAN ELECTRICAL CODE AND INSPECTED BY NSPI.
4. UNDERGROUND SERVICE CONDUIT AND GROUND MUST BE PROTECTED BY A U-GUARD AND BONDED AS PER CEC.
5. ALL SCREWS IN THE SERVICE SWITCH ARE TO BE NEVER SEIZED, AND MOUNTING SCREWS ARE TO BE STAINLESS STEEL ONLY.

HALIFAX

STANDARD DETAIL

120 240 VOLT STUB POLE SERVICE WITH GFCI's

DATE:	2021	REFERENCE	APPROVED
SCALE:	NTS		FIG No.: HRM 148

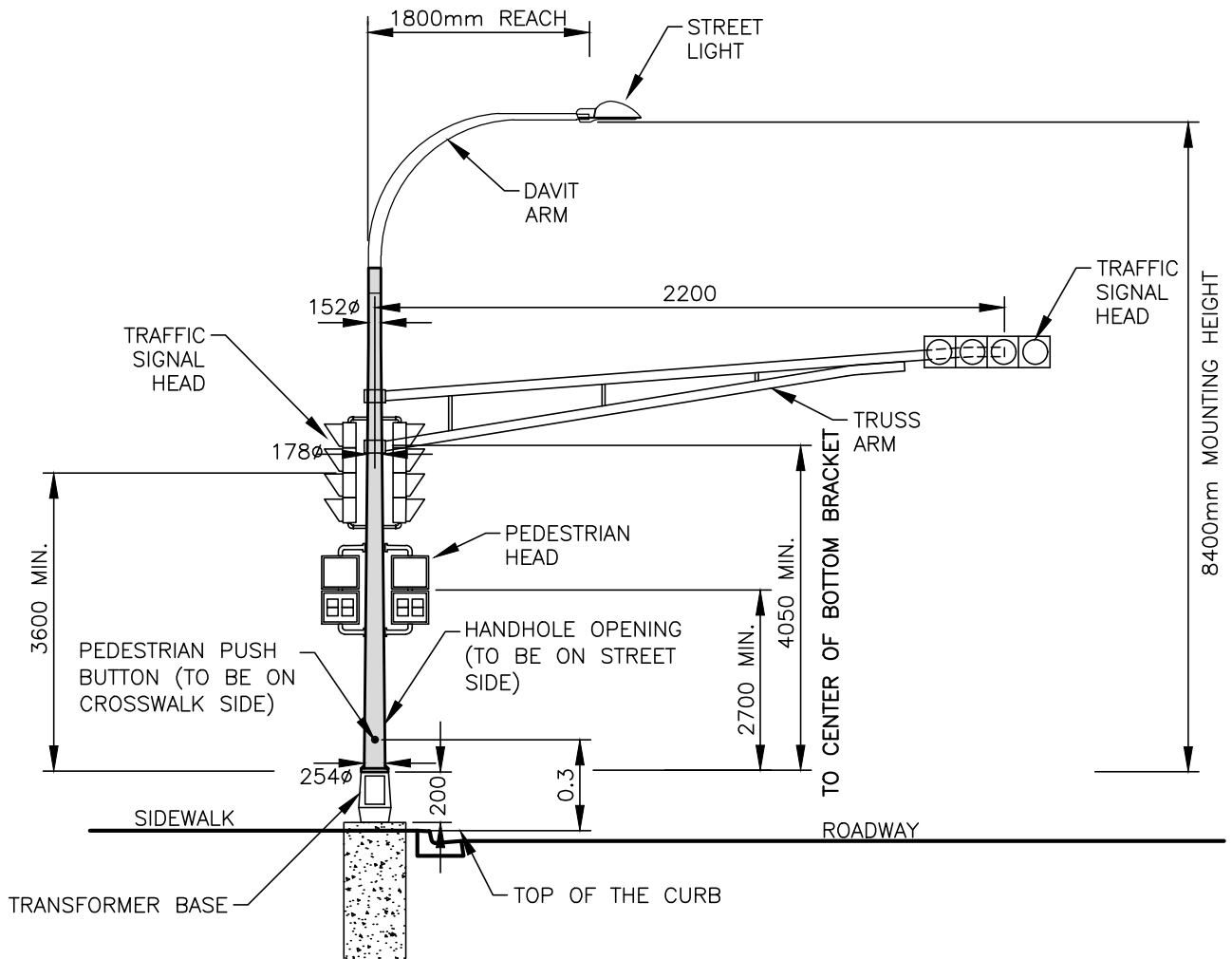

NOTES:

1. BUTTONS TO BE WITHIN ARMS REACH FROM THE PLACE WHERE PEDESTRIANS WAIT TO CROSS.
2. DIMENSIONS IN MILLIMETRES.

HALIFAX

STANDARD DETAIL

**TRAFFIC SIGNAL STREETLIGHT
COMBINATION POLE**

DATE:	2021	REFERENCE	APPROVED
SCALE:	NTS		FIG No.: HRM 149

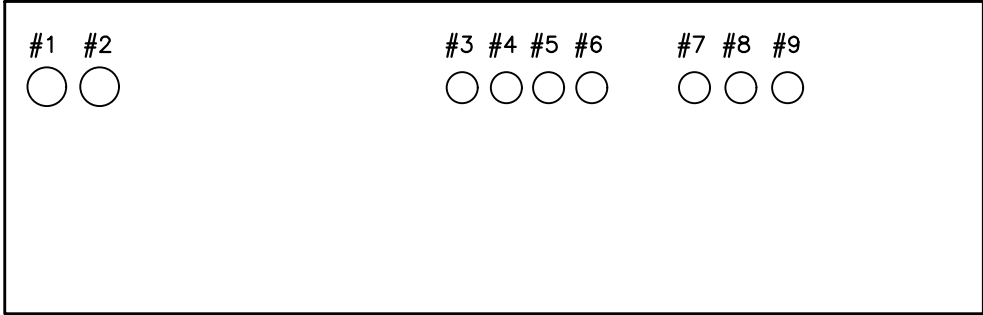

CONDUIT LAYOUT DESCRIPTION:

- #1 - NSP SERVICE (50mm PVC)
- #2 - SPARE STUBBED UNDERGROUND (50mm PVC)
- #3 - BASE #1 (32mm PVC)
- #4 - BASE #2 (32mm PVC)
- #5 - TRAFFIC CONTROLLER (32mm PVC)
- #6 - PARK LIGHTING POLE #4 (32mm PVC)
- #7 - SPARE STUBBED UNDERGROUND (32mm PVC)
- #8 - SPARE STUBBED UNDERGROUND (32mm PVC)
- #9 - SPARE STUBBED UNDERGROUND (32mm PVC)

<h1>HALIFAX</h1>		
STANDARD DETAIL		
POWER ENCLOSURE CONCRETE PAD TOP VIEW		
DATE: 2021	REFERENCE	APPROVED
SCALE: NTS		FIG No.: HRM 150

LEGEND

- GREEN
- RED
- BLACK
- BLUE
- YELLOW
- ORANGE
- PINK

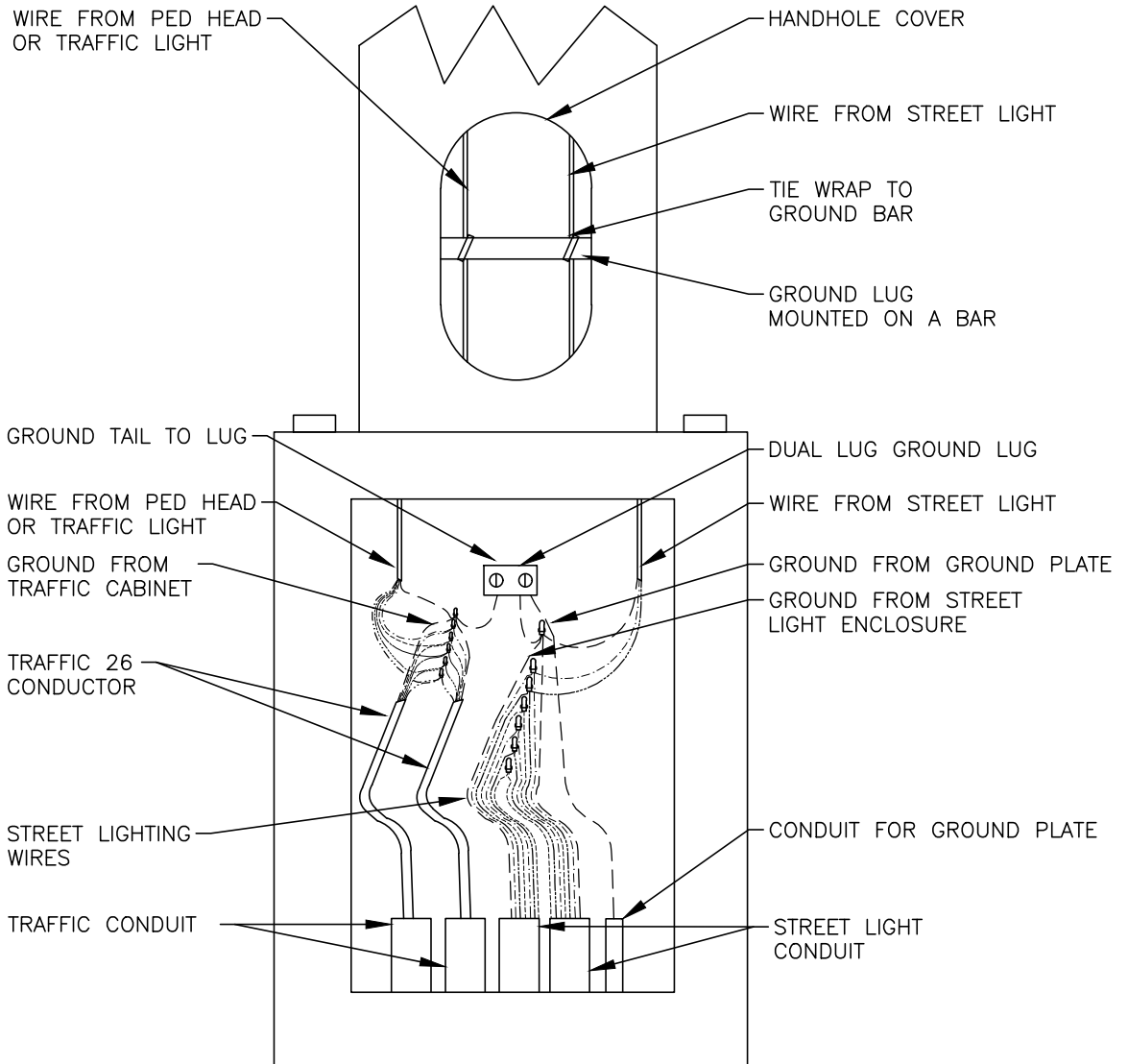

HALIFAX

STANDARD DETAIL

**TRANSFORMER BASE
GROUNDING—MODEL**

DATE:	2021	REFERENCE	APPROVED
SCALE:	NTS		FIG No.: HRM 151

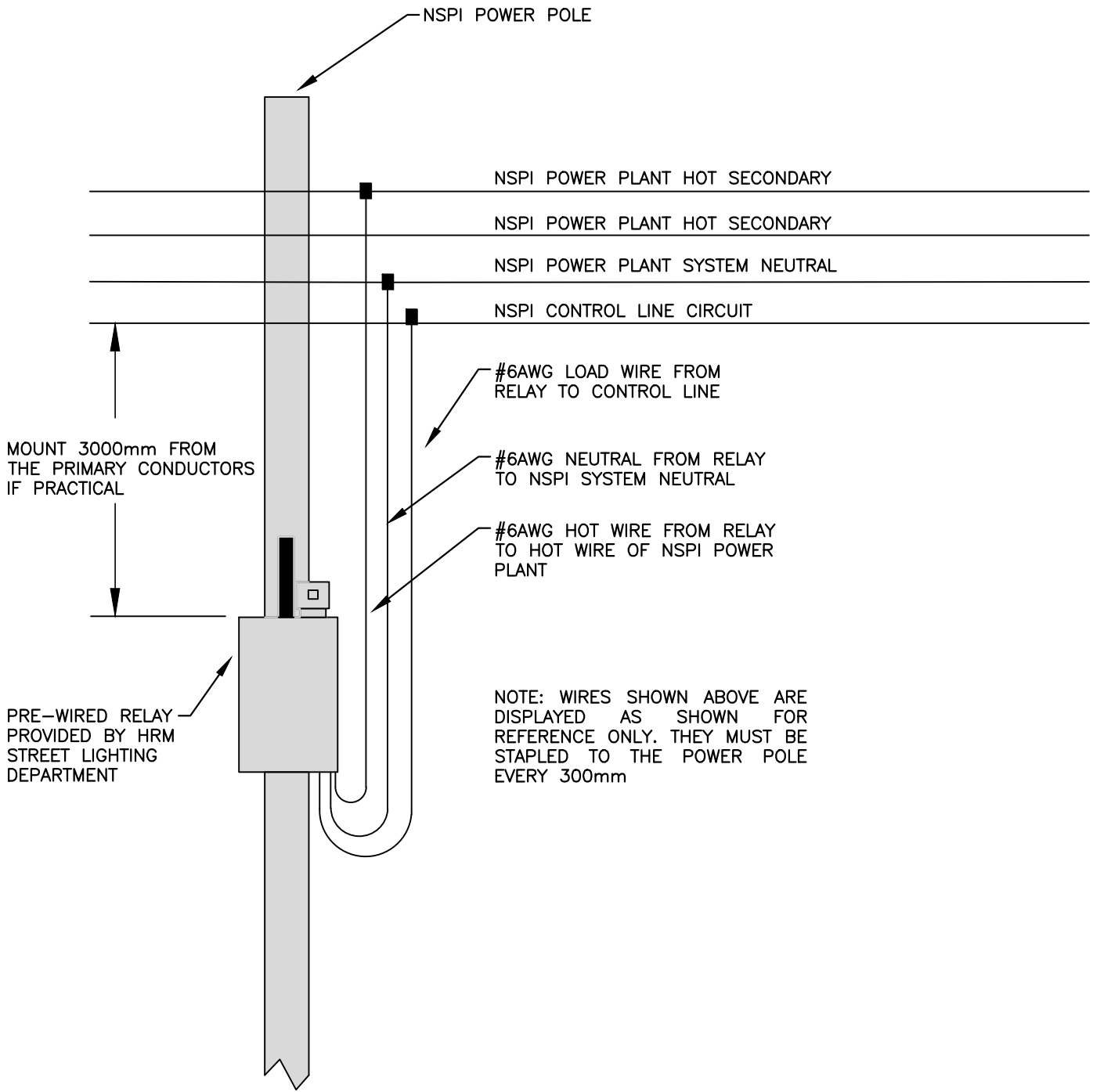

NOTES:

1. ALL WORK MUST BE IN COMPLIANCE WITH THE LATEST EDITION OF THE CANADIAN ELECTRICAL CODE.
2. ANY WORK DONE IN OR AROUND PRIMARY CONDUCTORS MUST BE PERFORMED BY A QUALIFIED PERSON AS PER HRM AND NSPI.
3. WHEN MOUNTING THE RELAY POSITION THE PHOTOEYE AWAY FROM THE NEAREST LIGHT FIXTURE.
4. ALL CONNECTIONS TO POWER NSPI POWER PLANT ARE TO BE MADE WITH TYCO KZ EP 4/0 PIERCING CONNECTORS.

HALIFAX		
STANDARD DETAIL		
TYPICAL RELAY INSTALLATION		
DATE:	REFERENCE	APPROVED
2021		
SCALE:		FIG No.:
NTS		HRM 152

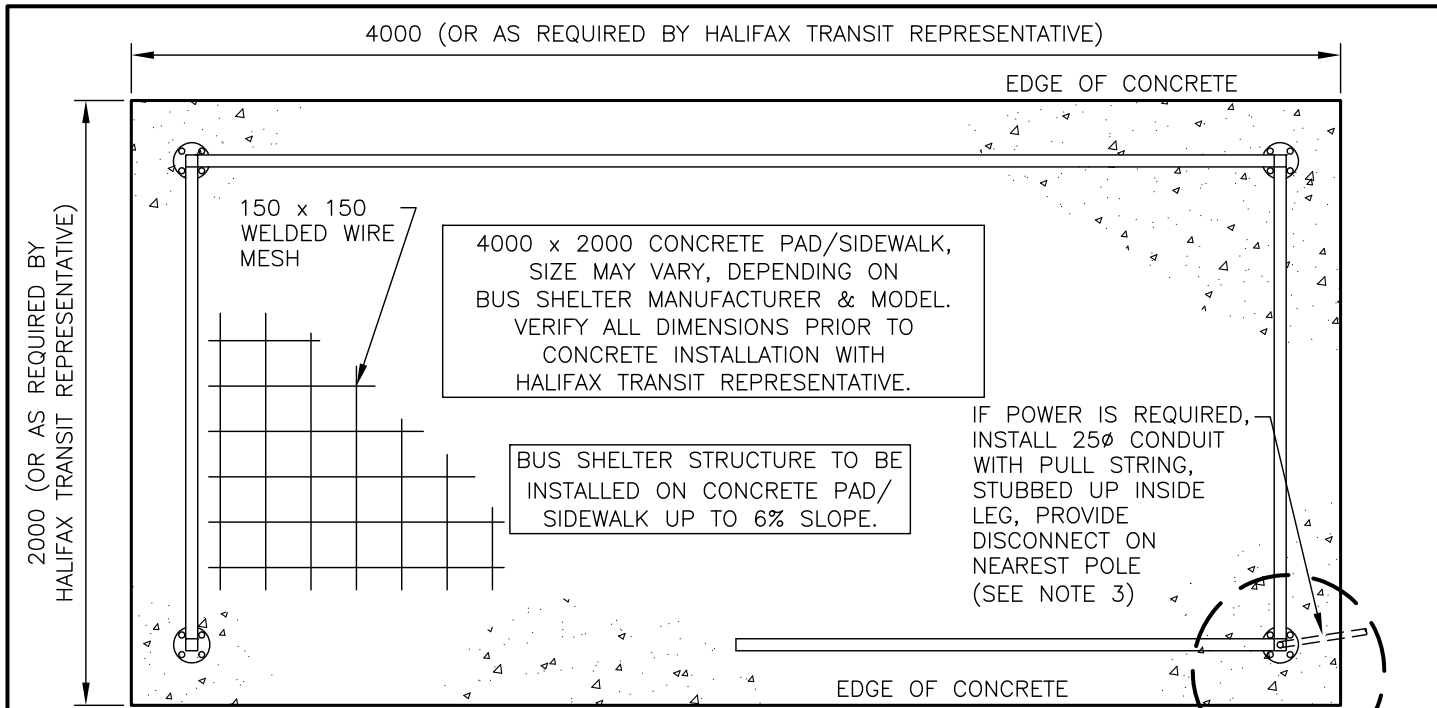

PLAN VIEW

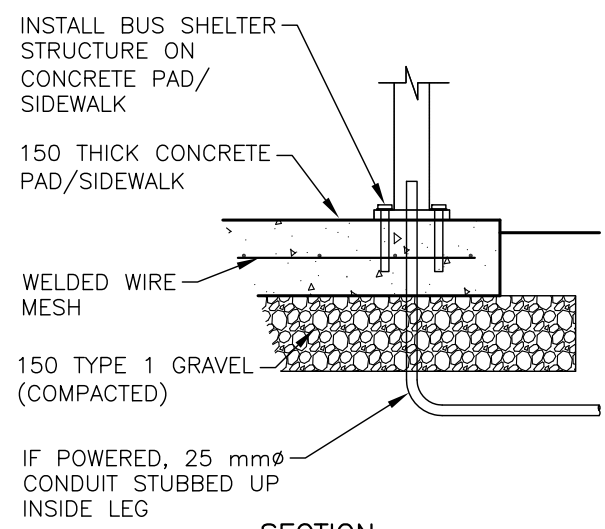

SECTION

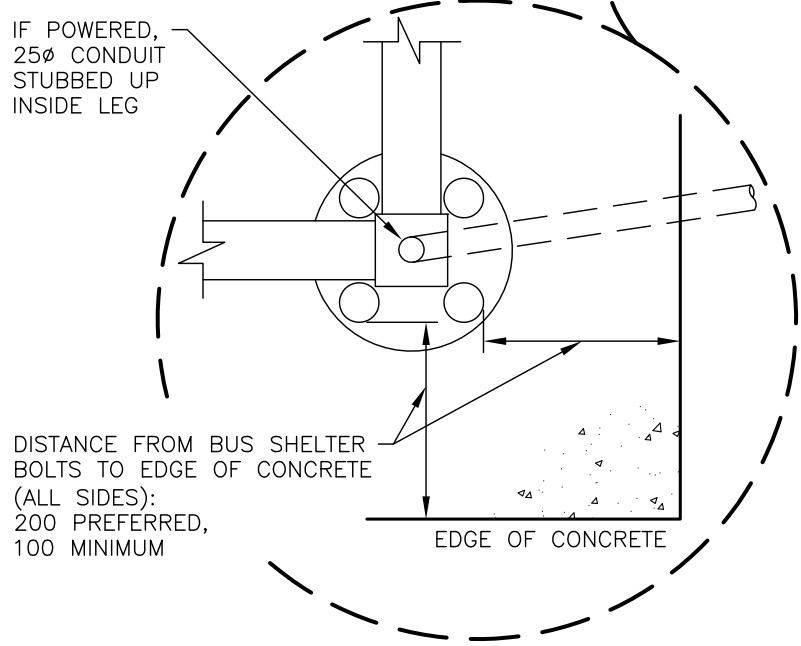

NOTES:

1. BEFORE ORDERING MATERIALS AND PRIOR TO CONSTRUCTION, VERIFY ALL EQUIPMENT AND SHELTER REQUIREMENTS WITH HALIFAX TRANSIT REPRESENTATIVE.
2. FOR INSTALLATION OF BUS SHELTER STRUCTURE FOLLOW MANUFACTURER'S INSTALLATION INSTRUCTIONS.
3. POWER CAN BE RUN INTO ANY OF THE SHELTER LEGS – CONTACT TRANSIT TO CONFIRM.
4. DIMENSIONS ARE IN MILLIMETRES.

HALIFAX		
STANDARD DETAIL		
BUS STOP SHELTER ON CONCRETE SIDEWALK		
DATE:	REFERENCE	APPROVED
2021		
SCALE:		FIG No.:
NTS		HRM 153

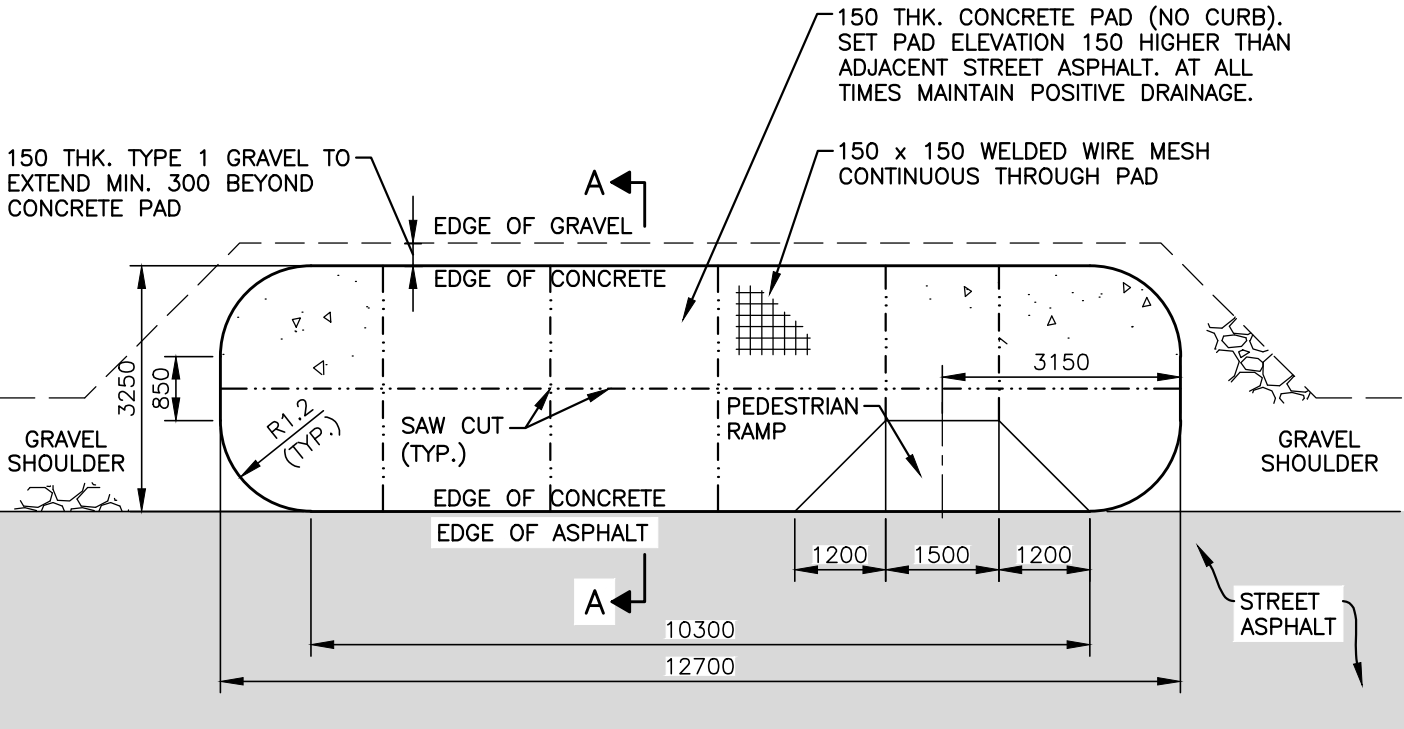

PLAN VIEW

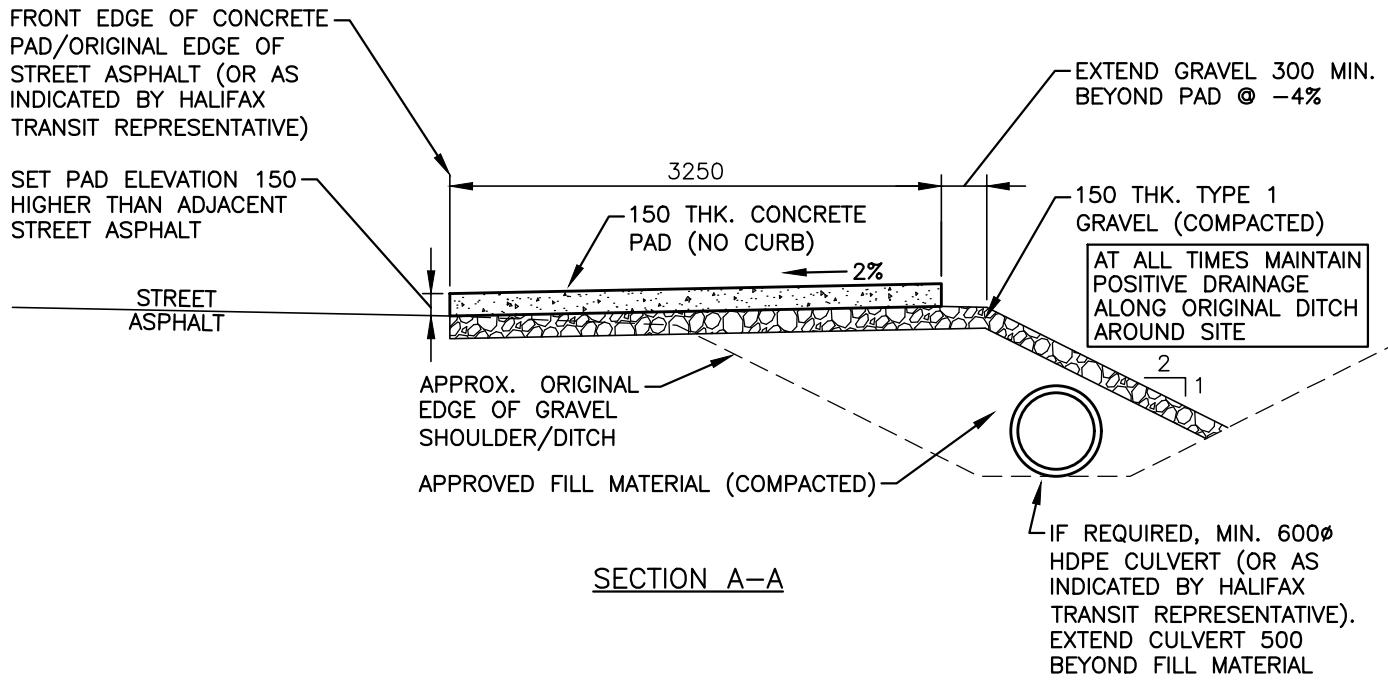

SECTION A-A

NOTES:

- BEFORE ORDERING MATERIALS AND PRIOR TO CONSTRUCTION, VERIFY ALL DIMENSIONS AND REQUIREMENTS WITH HALIFAX TRANSIT REPRESENTATIVE.
- DIMENSIONS ARE IN MILLIMETRES.

HALIFAX

STANDARD DETAIL

**STAND ALONE CONCRETE
BUS STOP PAD**

DATE:	REFERENCE	APPROVED
2021		
SCALE:		FIG No.:
NTS		HRM 154

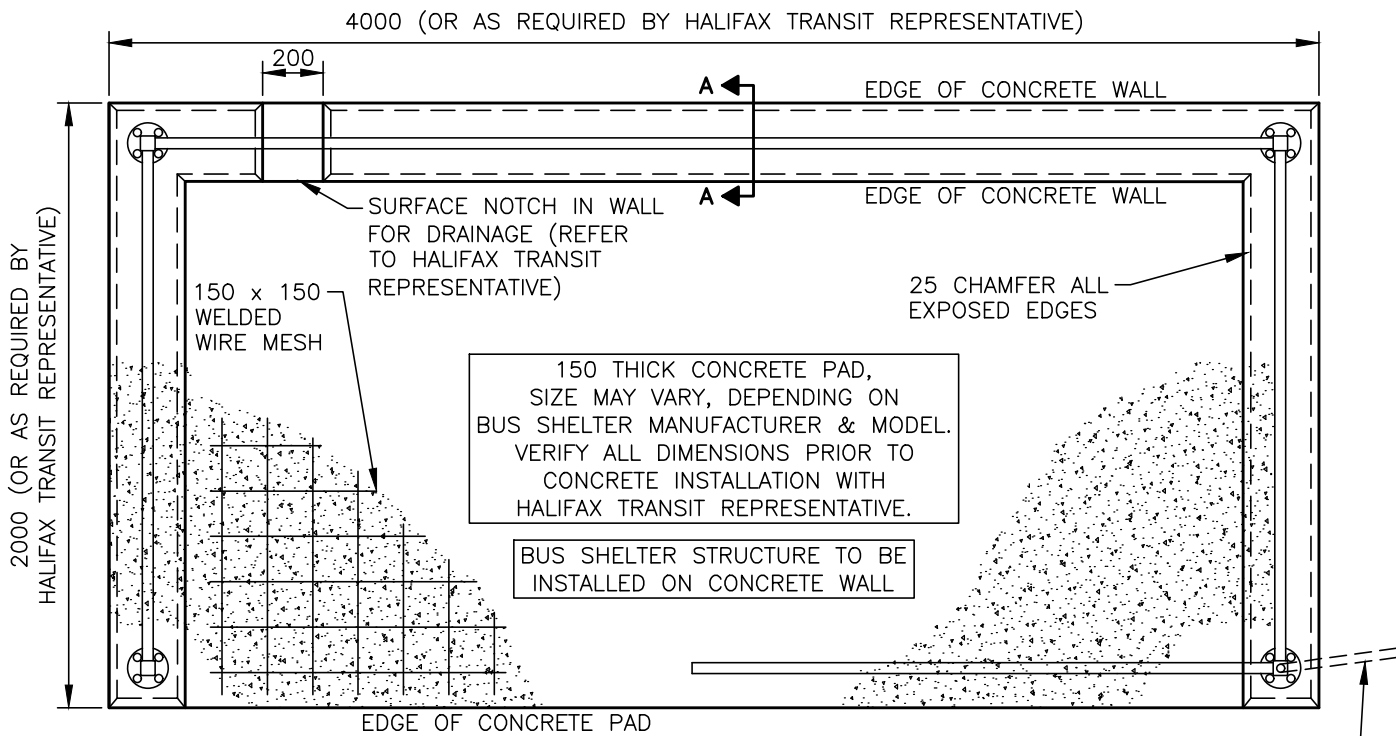

NOTE: ENSURE WALL IS CENTERED ON SHELTER BRACKETS

PLAN VIEW

IF POWER IS REQUIRED, INSTALL 25 ϕ CONDUIT WITH PULL STRING, STUBBED UP INSIDE WALL THRU LEG, PROVIDE DISCONNECT ON NEAREST POLE (SEE NOTE 3)

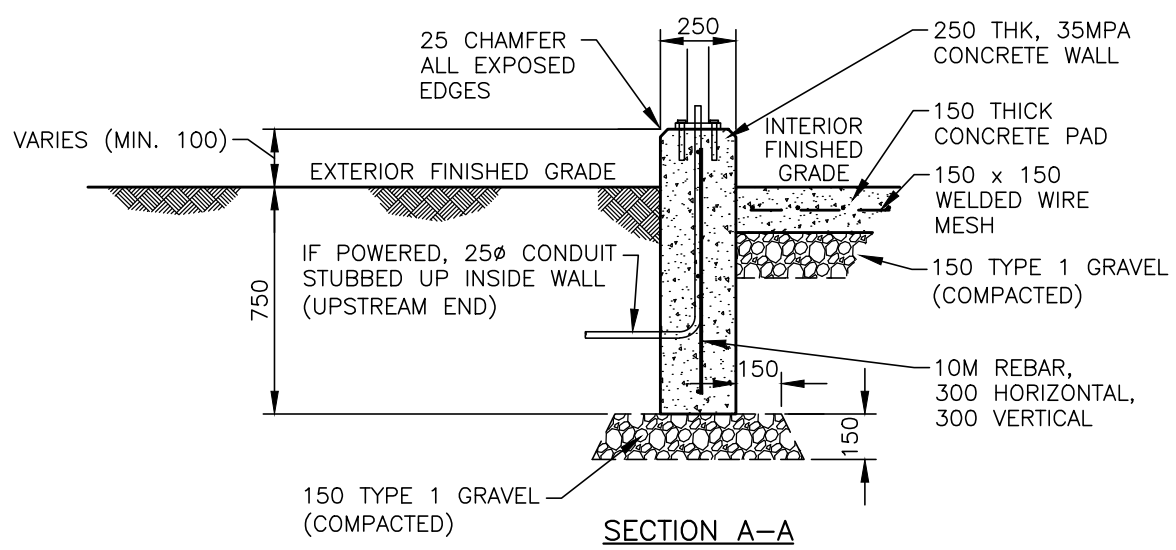

NOTES:

- BEFORE ORDERING MATERIALS AND PRIOR TO CONSTRUCTION, VERIFY ALL EQUIPMENT AND SHELTER REQUIREMENTS WITH HALIFAX TRANSIT REPRESENTATIVE.
- FOR INSTALLATION OF BUS SHELTER STRUCTURE FOLLOW MANUFACTURER'S INSTALLATION INSTRUCTIONS.
- POWER CAN BE RUN INTO ANY OF THE SHELTER LEGS - CONTACT TRANSIT TO CONFIRM.
- DIMENSIONS ARE IN MILLIMETRES.

HALIFAX

STANDARD DETAIL

BUS STOP SHELTER ON CONCRETE WALL

DATE:	2021	REFERENCE	APPROVED
SCALE:	NTS		FIG No.: HRM 155

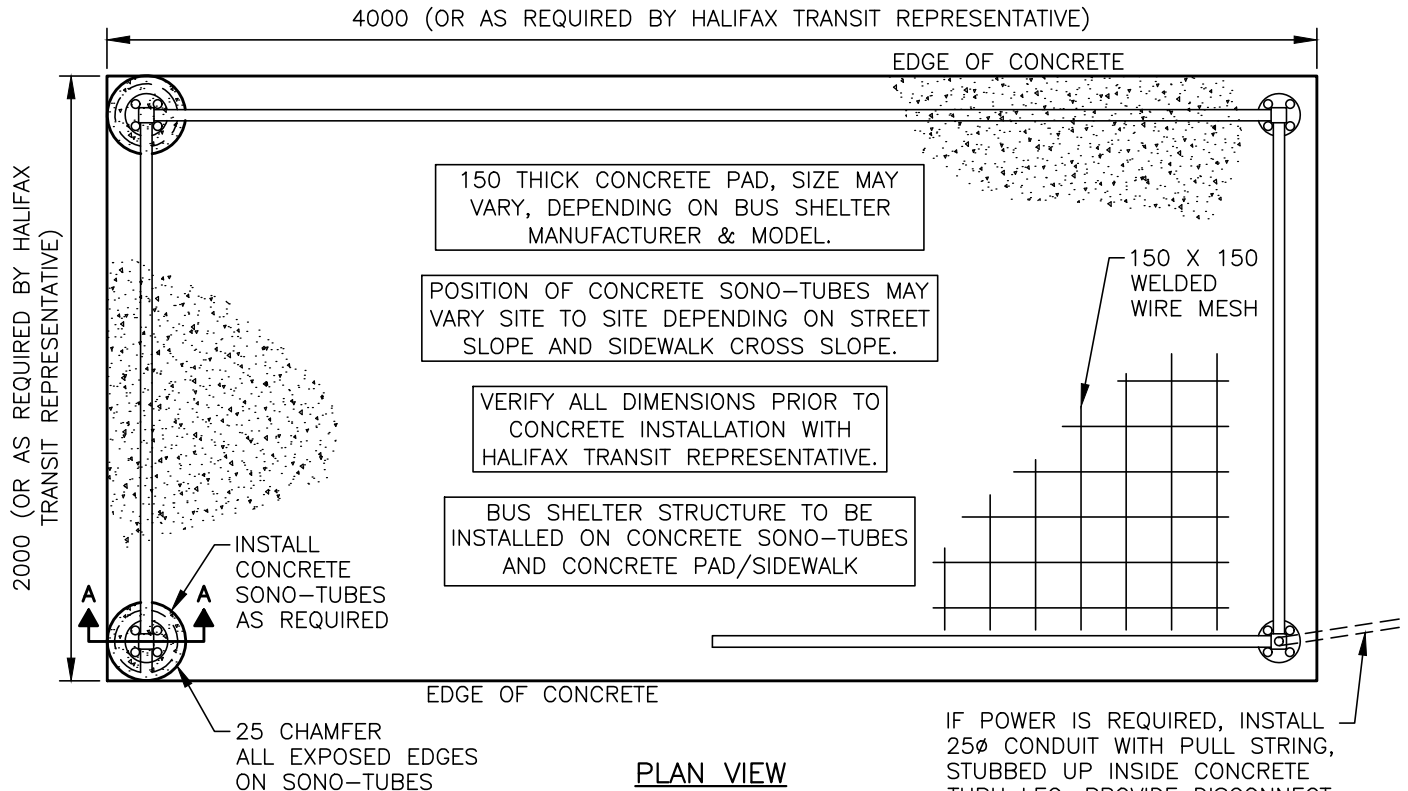

NOTE: ENSURE SONO-TUBE IS CENTERED ON SHELTER BRACKETS

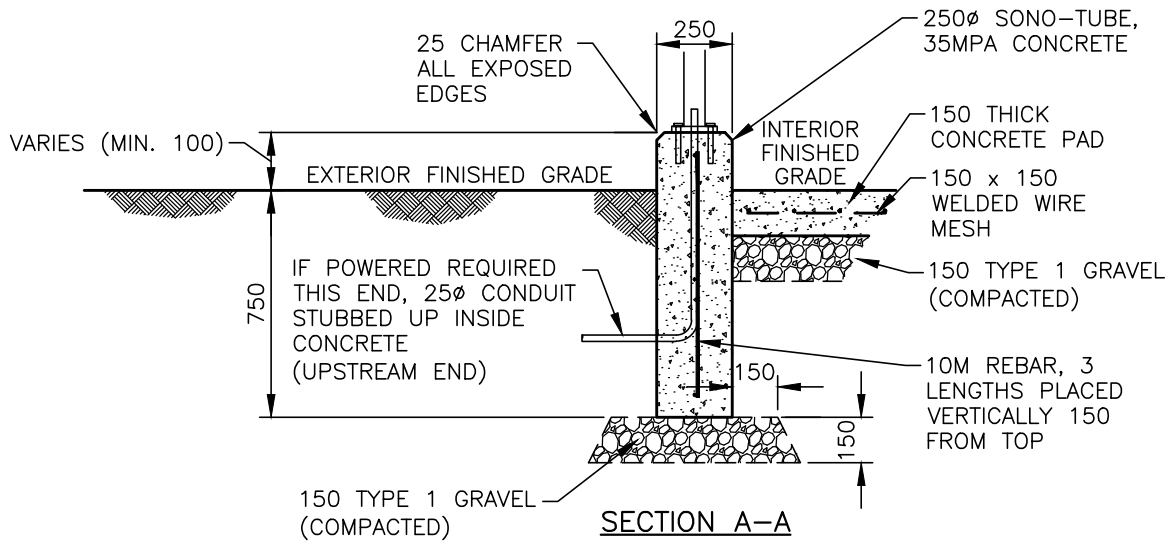

NOTES:

1. BEFORE ORDERING MATERIALS AND PRIOR TO CONSTRUCTION, VERIFY ALL EQUIPMENT AND SHELTER REQUIREMENTS WITH HALIFAX TRANSIT REPRESENTATIVE.
2. FOR INSTALLATION OF BUS SHELTER STRUCTURE FOLLOW MANUFACTURER'S INSTALLATION INSTRUCTIONS.
3. POWER CAN BE RUN INTO ANY OF THE SHELTER LEGS - CONTACT TRANSIT TO CONFIRM.
4. DIMENSIONS ARE IN MILLIMETRES.

HALIFAX

STANDARD DETAIL

**BUS STOP SHELTER ON
CONCRETE SONO-TUBES**

DATE:	2021	REFERENCE	APPROVED
SCALE:	NTS		FIG No.: HRM 156

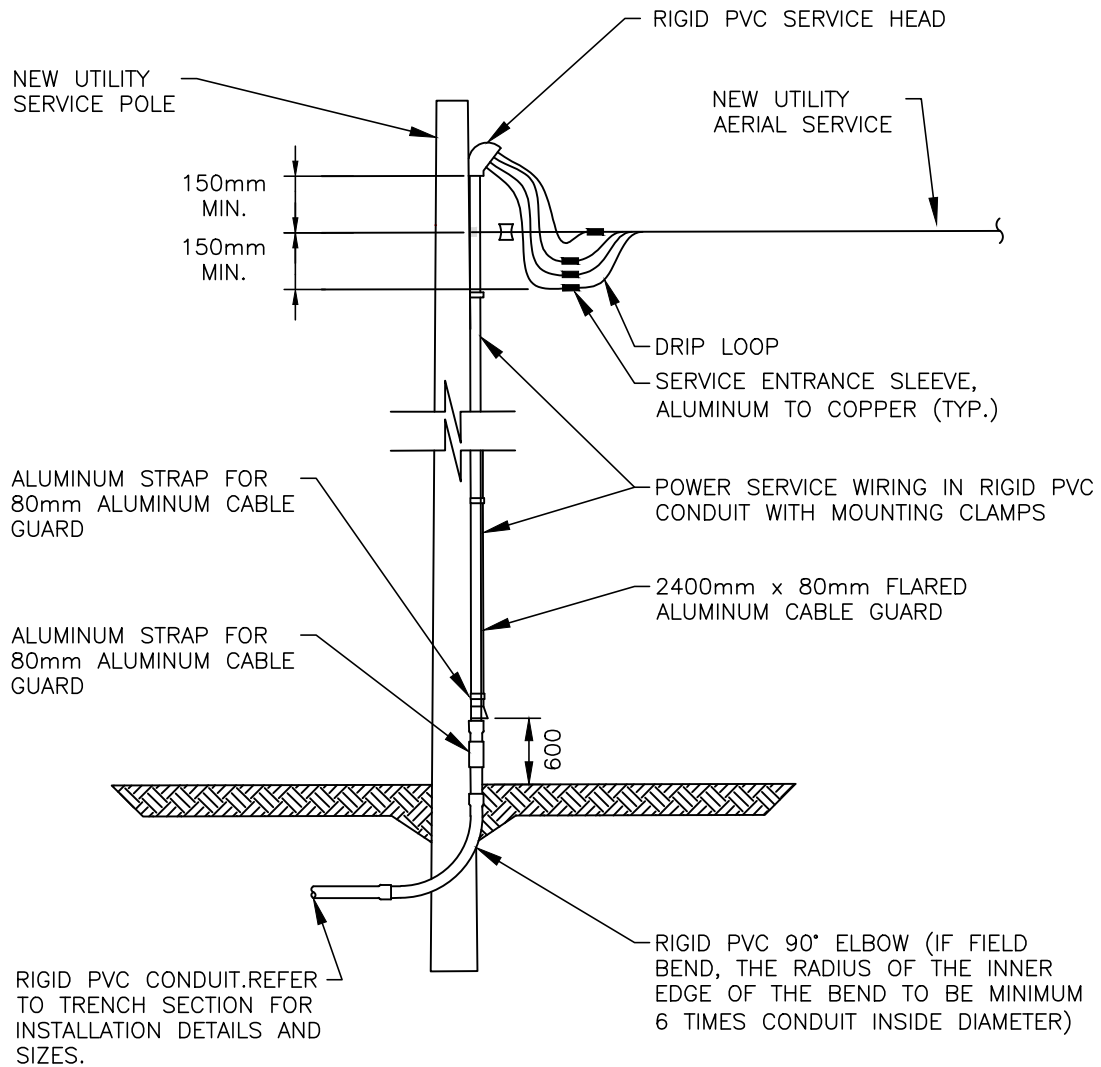

NOTES:

1. BREAKER MUST BE A DOUBLE POLE, NO SPARE SERVICE WIRES ARE ALLOWED.
2. CIRCUITS RATED AT MORE THAN 15Amps REQUIRE A CONTACTOR.
3. ALL WORK MUST BE IN COMPLIANCE WITH THE LATEST EDITION OF THE CANADIAN ELECTRICAL CODE AND INSPECTED BY NSPI
4. UNDERGROUND SERVICE CONDUIT AND GROUND MUST BE PROTECTED BY A U-GUARD AND BONDED AS PER CEC.
5. ALL SCREWS IN THE SERVICE SWITCH ARE TO BE NEVER SEIZED, AND MOUNTING SCREWS ARE TO BE STAINLESS STEEL ONLY.

HALIFAX

STANDARD DETAIL

UTILITY POLE
SERVICE DETAIL

DATE:	2021	REFERENCE	APPROVED
SCALE:	NTS		FIG No.: HRM 160

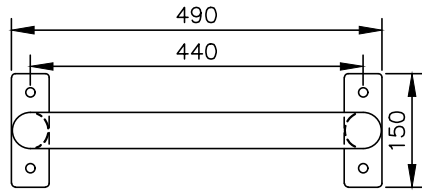

PLAN VIEW

HOT-DIPPED GALVANIZED STEEL OR
HOT-DIPPED GALVANIZED STEEL
WITH BLACK POWDER COAT

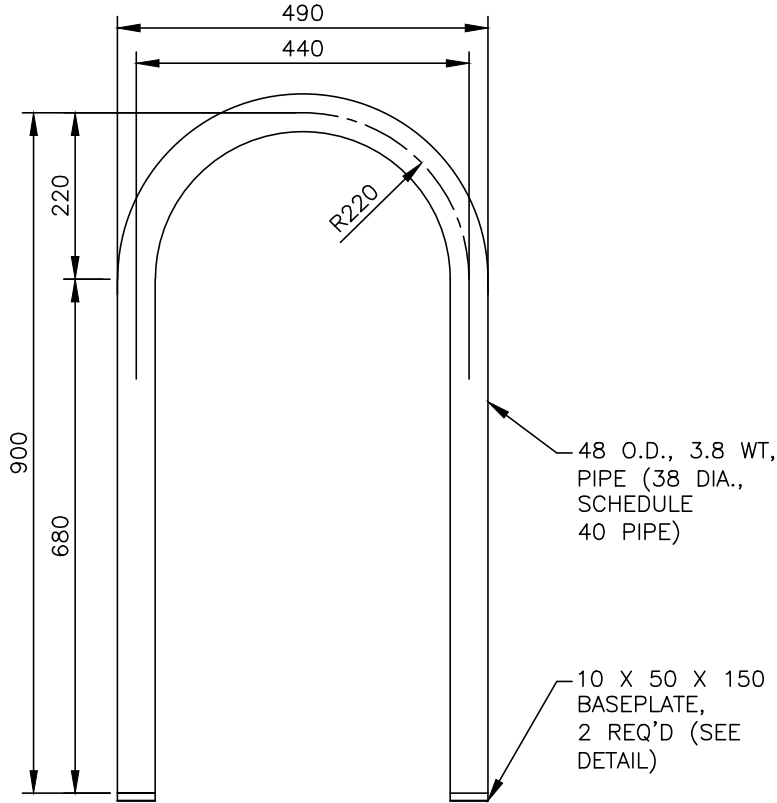

PROFILE VIEW

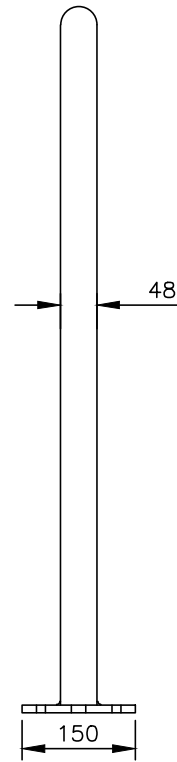

SECTION

NOTES:

1. ALL DIMENSIONS ARE IN MILLIMETRES.
2. VARIATION OF THE DIMENSIONS PROVIDED ARE PERMITTED, BUT MUST BE SHOWN ON SUBMITTED DRAWINGS.
3. BIKE RACKS TO BE ANCHORED TO POURED IN PLACE CONCRETE SURFACE WITH 10 mmØ X 125 mm EPOXY EXPANSION BOLTS (100 mm EMBEDMENT) OR APPROVED EQUIVALENT.

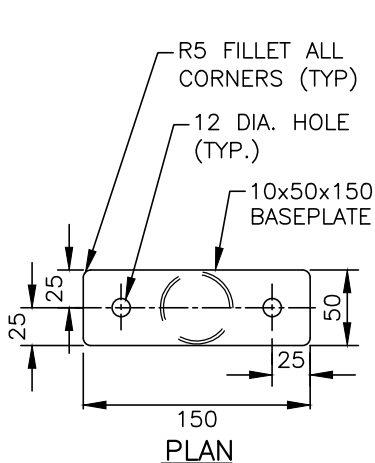

BASEPLATE DETAIL

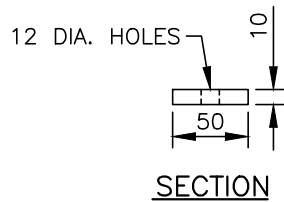

SECTION

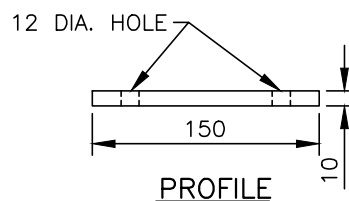

PROFILE

HALIFAX

STANDARD DETAIL

INVERTED U BIKE RACK

DATE:	2021	REFERENCE	APPROVED
SCALE:	NTS		FIG No.: HRM 165

HOT-DIPPED GALVANIZED STEEL OR
HOT-DIPPED GALVANIZED STEEL WITH BLACK POWDER COAT

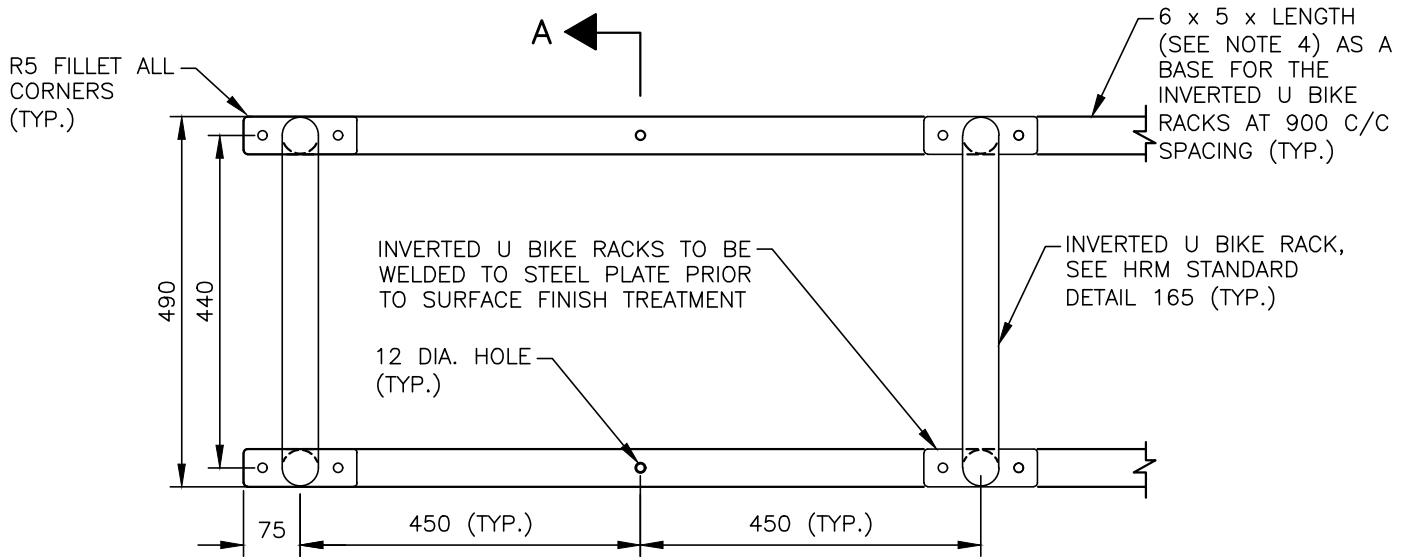

PLAN VIEW

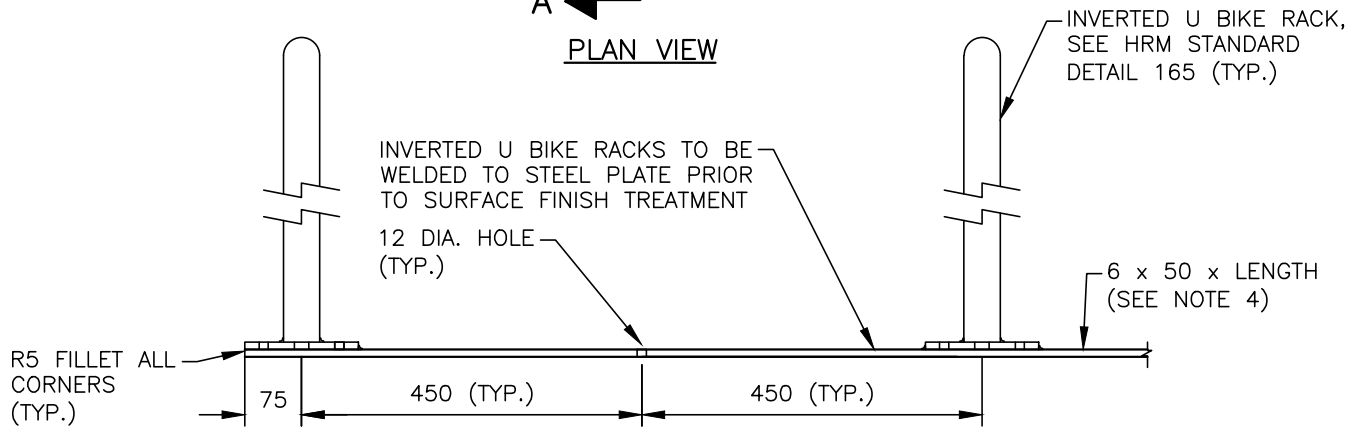

PROFILE VIEW

NOTES:

1. ALL DIMENSIONS ARE IN MILLIMETRES.
2. VARIATION OF THE DIMENSIONS PROVIDED ARE PERMITTED, BUT MUST BE SHOWN ON SUBMITTED DRAWINGS.
3. BIKE RACKS TO BE ANCHORED TO POURED IN PLACE CONCRETE SURFACE WITH 10 mm ϕ X 125 mm EPOXY EXPANSION BOLTS (100 mm EMBEDMENT) OR APPROVED EQUIVILANT.
4. MULTI BIKE RACK LENGTH WILL VARY FOR SERIES OF 2 TO 5 INVERTED U BIKE RACKS (AS REQUIRED).

INVERTED U BIKE RACK, SEE HRM STANDARD DETAIL 165

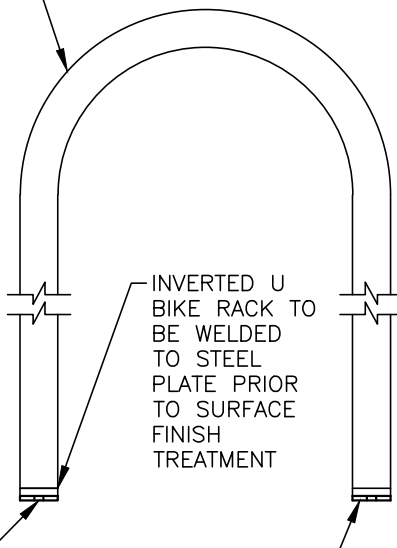

SECTION A-A

HALIFAX

STANDARD DETAIL

MULTI INVERTED U BIKE RACK

DATE:	2021	REFERENCE	APPROVED
SCALE:	NTS		FIG No.: HRM 166

HOT-DIPPED GALVANIZED STEEL OR
HOT-DIPPED GALVANIZED STEEL WITH
BLACK POWDER COAT

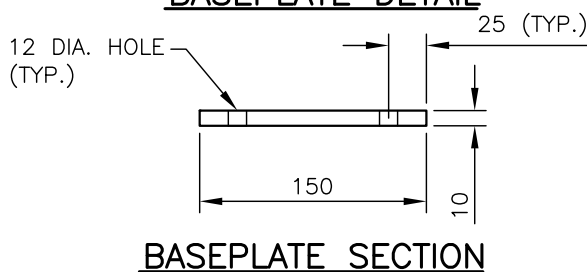
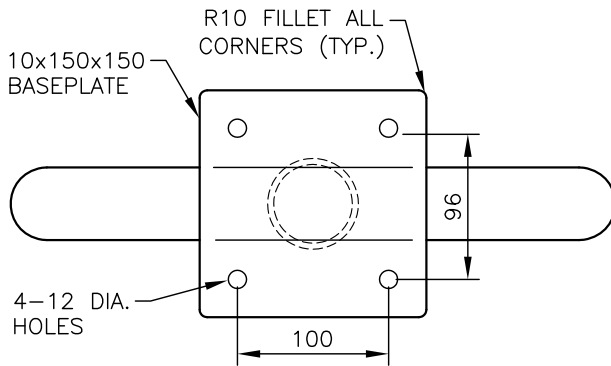
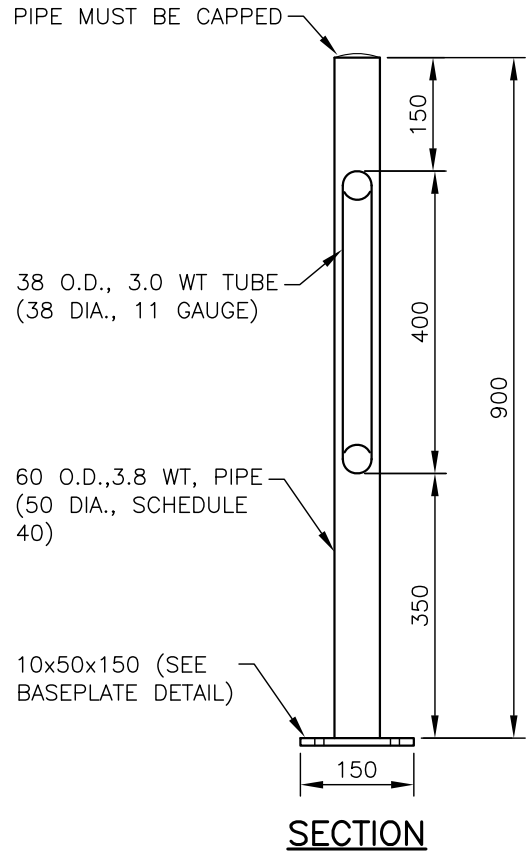
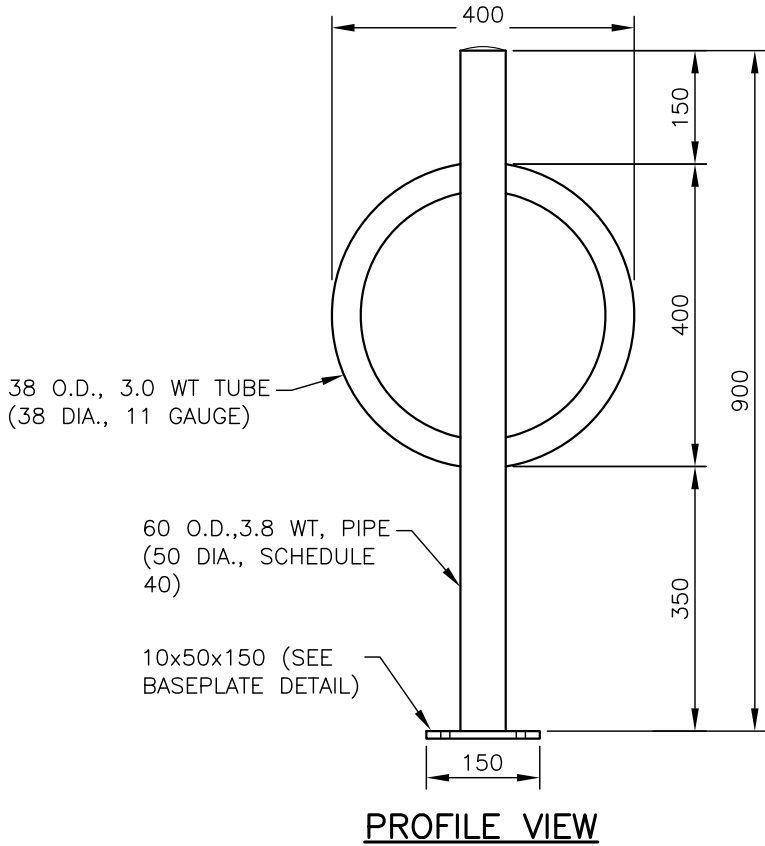
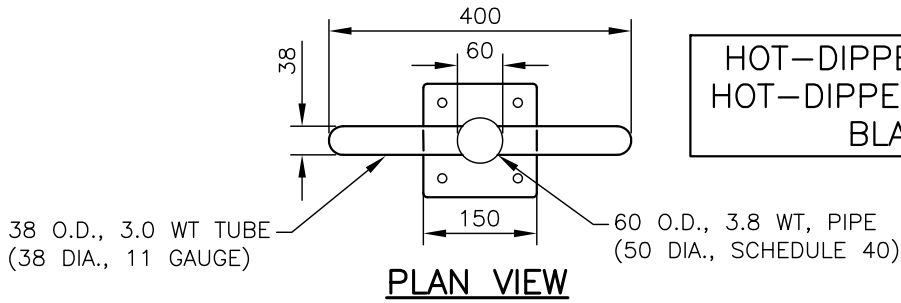

NOTES:

1. ALL DIMENSIONS ARE IN MILLIMETRES.
2. VARIATION OF THE DIMENSIONS PROVIDED ARE PERMITTED, BUT MUST BE SHOWN ON SUBMITTED DRAWINGS.
3. BIKE RACKS TO BE ANCHORED TO POURED IN PLACE CONCRETE SURFACE WITH 10 mmØ X 125 mm EPOXY EXPANSION BOLTS (100 mm EMBEDMENT).

HALIFAX

STANDARD DETAIL

POST & RING BIKE RACK

DATE: 2021	REFERENCE	APPROVED
SCALE: NTS		FIG No.: HRM 167

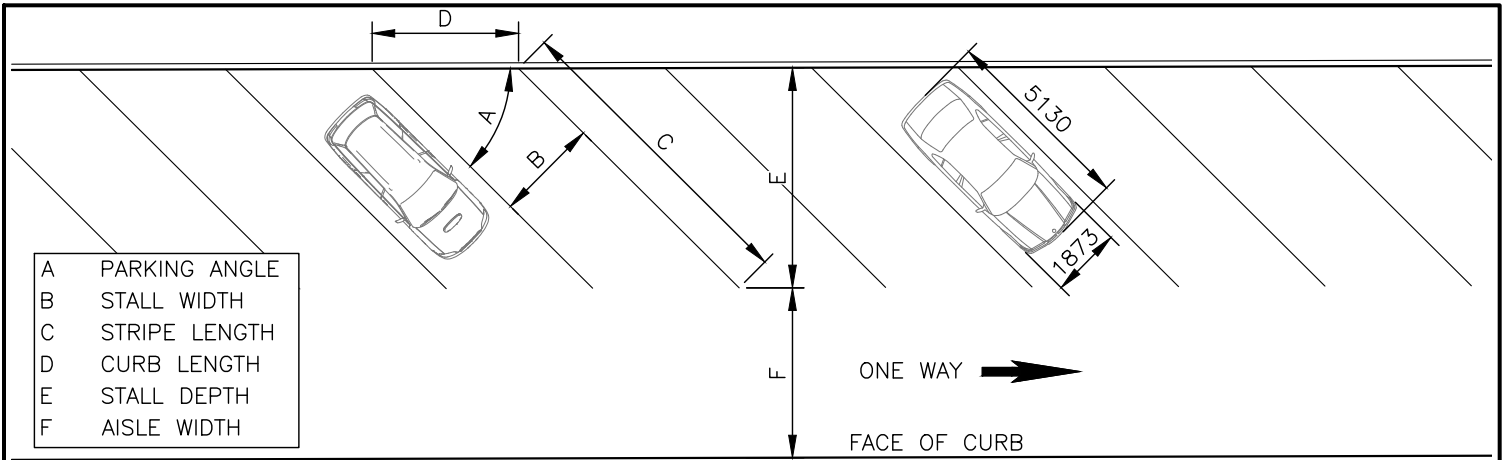

- A PARKING ANGLE
- B STALL WIDTH
- C STRIPE LENGTH
- D CURB LENGTH
- E STALL DEPTH
- F AISLE WIDTH

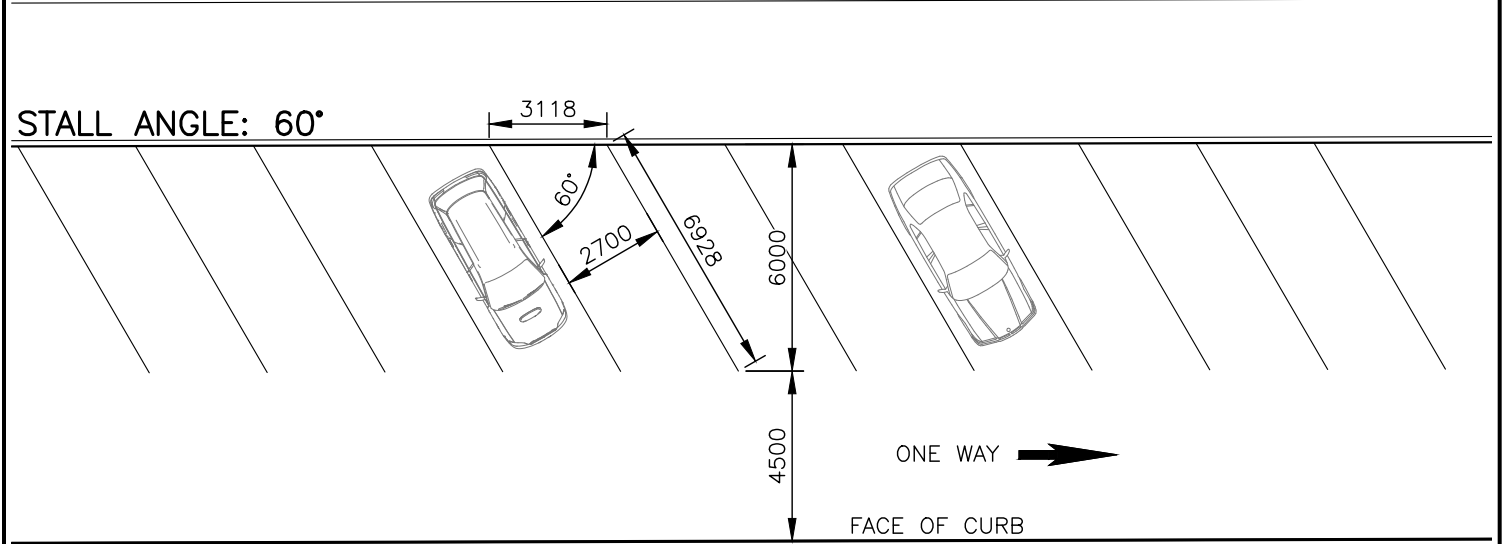
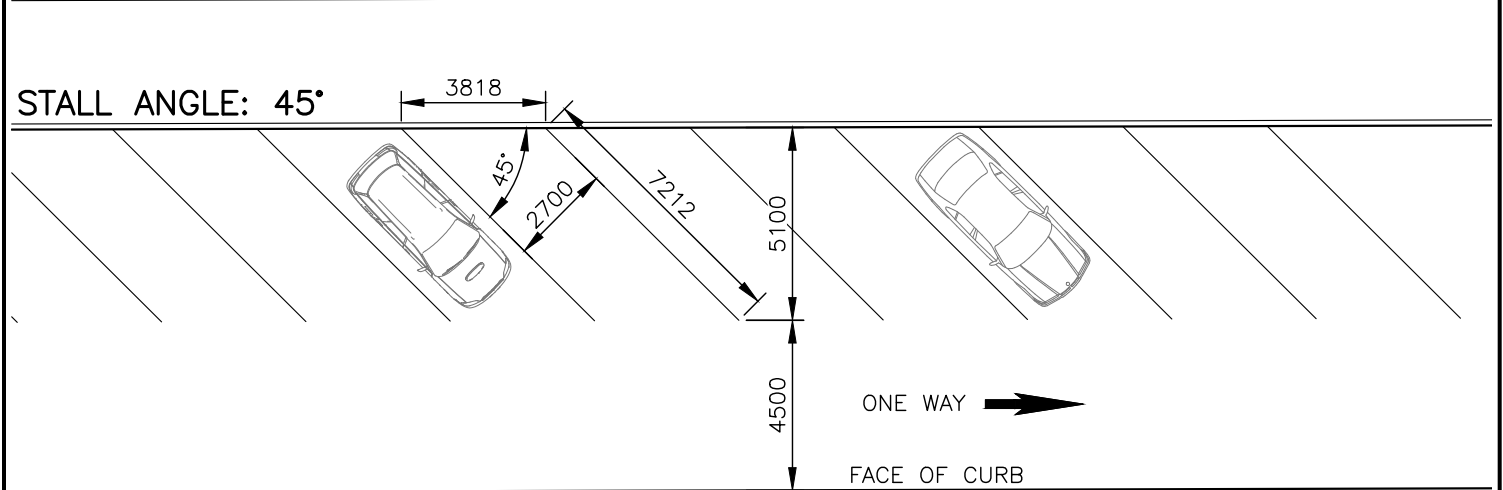

NOTES:

1. STREETS SHOULD BE ONE-WAY, CONVERTED TO ONE-WAY, OR HAVE MEDIANS BETWEEN DIRECTIONS OF TRAVEL
2. THE ACUTE ANGLE OF THE STALL MUST BE IN THE SAME DIRECTION OF TRAFFIC FLOW (TO INHIBIT POTENTIAL OF 'DRIVE-IN' PARKING)
3. THE DIMENSIONS SHOULD BE USED AS A GUIDE, RECOGNIZING THAT:
 - 3.1. WIDER AISLES MAY BE REQUIRED ON PRIMARY ROUTES FOR LARGER VEHICLES
 - 3.2. TURNING REQUIREMENTS SHOULD BE CONSIDERED ON ALL APPLICATIONS
4. IN BOTH ABOVE CASES, PARKING WOULD NOT BE PERMITTED ALONG THE OPPOSITE CURB

<h1 style="margin: 0;">HALIFAX</h1>		
STANDARD DETAIL		
BACK IN ANGLE PARKING 60° AND 45°		
DATE: 2021	REFERENCE	APPROVED
SCALE: NTS		FIG No.: HRM 169

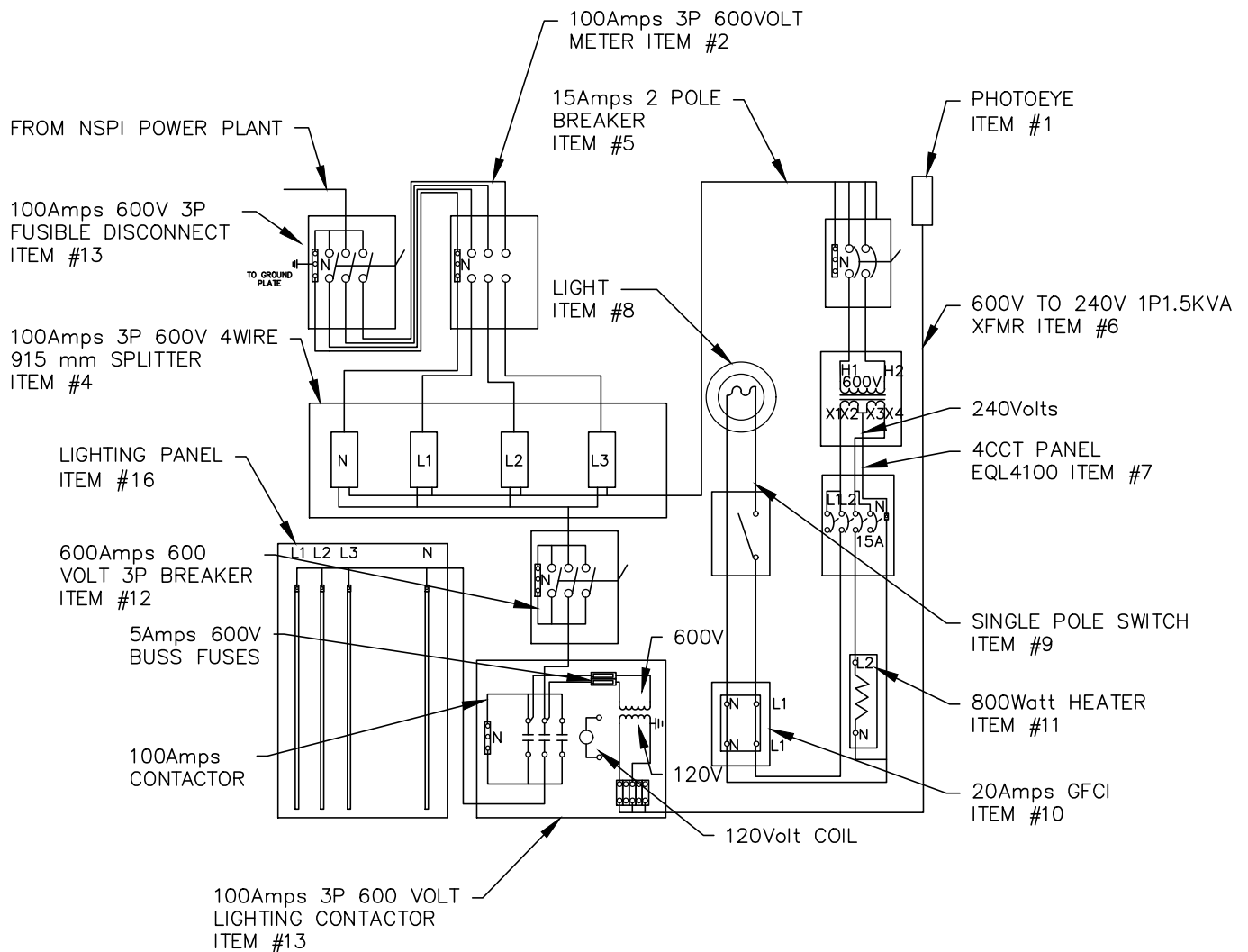

NOTES:

1. REFER TO HRM 171 FOR DESCRIPTIONS AND RULINGS.

<h1 style="margin: 0;">HALIFAX</h1>		
STANDARD DETAIL		
STREET LIGHT POWER ENCLOSURE SINGLE LINE DIAGRAM		
DATE:	REFERENCE	APPROVED
2021		
SCALE:		FIG No.:
NTS		HRM 170

DESCRIPTIONS AND RULINGS

PART NUMBERING AND DESCRIPTIONS:

1. BEL PART NUMBER #HDM727224FSS-M 72x72 C/W 4m AND INSTALLED BACK PLATE.
2. STREET LIGHTING POWER METER BASE 100Amps 600VOLT 3 Phase PART#PL17-TCV-IN.
3. 100Amps 3P 600VOLT FUSIBLE SIEMENS ID363NF C/W 100Amps 600VOLT FUSES.
4. BEL 200Amps 3P 600VOLT SPLITTER PART#T3204.
5. 15Amps 2P 600VOLT BREAKER SIEMENS PART#ED63B015L C/W E2NIS ENCLOSURE.
6. 1.5KVA XFMR HAMMOND PART#Q1C5PEKF.
7. 4 X 15Amps 1P BREAKER SIEMENS PART#Q115 C/W EQL4100 ENCLOSURE.
8. RAB DEMVCS100CG LIGHT C/W DEMGD100CGS CAGE C/W CFL LIGHTBULB.
9. RAB DEVICE BOX IBCS100CN C/W WEATHERPROOF PVC COVER AND COMMERCIAL GRADE SINGLE POLE SWITCH LEVCS1152W.
10. RAB DEVICE BOX IBCS100CN C/W WEATHERPROOF PVC COVER AND 20AMP T SLOT GFCI LEV7899W.
11. 800WATT HEATER CALORITECH PART#PH80011.
12. 100Amps 3P 600VOLT BREAKER SIEMENS PART#ED63B100L C/W E2NIS ENCLOSURE.
13. 100Amps LEN CONTACTOR C/W HOA IN 410mmx410mmx205mm ENCLOSURE.
14. RAB DEVICE BOX IBCS100CN C/W BLANK PVC WEATHERPROOF COVER SCEBRC1510
15. INTERMATIC PHOTOCELL PART#K4221C.
16. SIEMENS DISTRIBUTION PANEL PART#P1L42ML125CBS 3P 4WIRE 600VOLT 42 CRT.
17. PVC JUNCTION BOX CAPABLE OF HOLDING EXTRA FUSES AND AN EXTRA COIL.

CONDUIT AND WIRE SIZING:

- A. 53mm CONDUIT C/W 4 x #3 RWU90 & 1 x #8 GRN CONDUCTORS
- B. 41mm CONDUIT C/W 4 x #3 RWU90 & 1 x #8 GRN CONDUCTORS
- C. 25mm CONDUIT C/W 1 x #6 GRN 1 1
- D. NMFC OR PVC C/W 2 x #12 RWU90 & #12 GRN 2 2
- E. 25mm CONDUIT C/W 2 x #10 RWU90 & #8 GRN

RULES AND REGULATIONS:

1. ALL WIRING MUST BE DONE IN ACCORDANCE WITH THE LATEST EDITION OF THE CANADIAN ELECTRICAL CODE.
2. CABINET MUST BE CSA APPROVED.
3. CABINET DOORS MUST HAVE BARS TO HOLD DOORS OPEN.
4. CABINET DOORS MUST BE LOCKABLE AND BE ABLE TO ACCEPT A PADLOCK.
5. CABINET MUST HAVE A REMOVEABLE CENTER POST FOR THE DOORS.
6. CABINET DOORS MUST HAVE A GASKET TO PREVENT MOISTURE FROM ENTERING THE CABINET.
7. ALL MOUTING SCREWS MUST BE STAINLESS.
8. CABINET MUST HAVE A DRAWING HOLDER AND ALL WIRING SCHEMATICS WITH IT.
9. MANUFACTURER MUST PROVIDE REPLACEMENT FUSES, LIGHTBULB, AND A SPARE COIL. TO BE MOUTED IN A PVC JUNCTION BOX IN A CONVIENT LOCATION.
10. ALL COMPONENTS MUST BE LABELED WITH LAMACOIDS IE; VOLTAGE, CURRENT, AND CIRCUIT.
11. ITEM #7 MUST BE LABELED WITH LAMACOIDS TO INDICATE WHAT THE CIRCUIT IS FEEDING.

HALIFAX

STANDARD DETAIL

**STREET LIGHT POWER
ENCLOSURE PARTS LIST**

DATE:	2021	REFERENCE	APPROVED
SCALE:	NTS		FIG No.: HRM 171

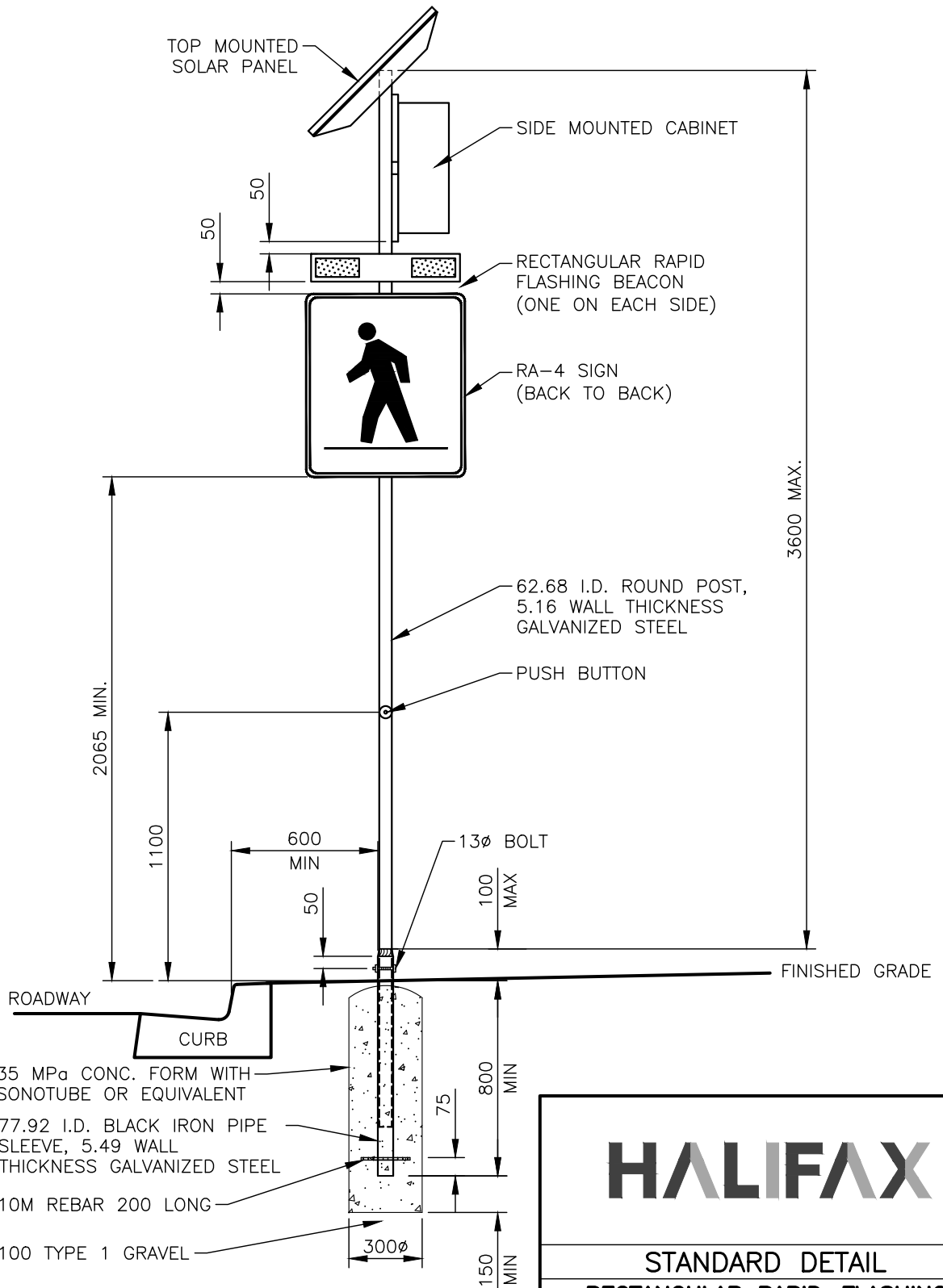

- 35 MPa CONC. FORM WITH SONOTUBE OR EQUIVALENT
- 77.92 I.D. BLACK IRON PIPE SLEEVE, 5.49 WALL THICKNESS GALVANIZED STEEL
- 10M REBAR 200 LONG
- 100 TYPE 1 GRAVEL

NOTE:

1. DIMENSIONS ARE IN MILLIMETRES.

HALIFAX

STANDARD DETAIL

RECTANGULAR RAPID-FLASHING BEACON SIGNAL CONFIGURATION (SOLAR PANEL)

DATE:	2021	REFERENCE	APPROVED
SCALE:	1:25		FIG No.:
			HRM 172

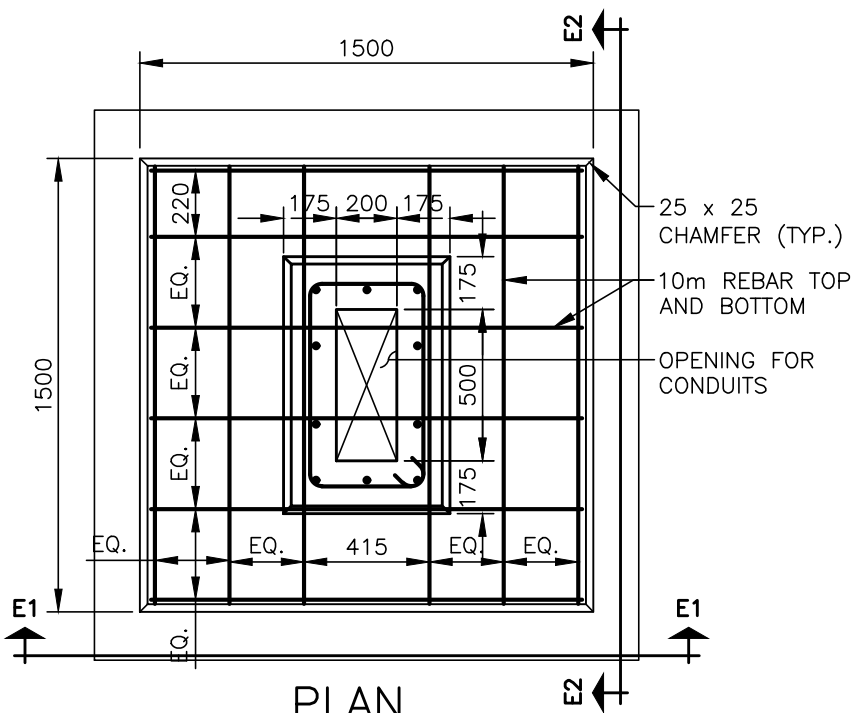

PLAN
1:25

NOTES:

1. CONCRETE 28 DAY COMPRESSIVE STRENGTH TO BE 35 MPa.
2. PROVIDE MIN. 50 COVER FOR ALL REBAR (UNLESS NOTED OTHERWISE).
3. PROVIDE GROUNDING FOR CONTROLLER CABINET.
4. IN ADDITION TO CONDUITS SPECIFIED ON EQUIPMENT DRAWINGS/SPECIFICATIONS, PROVIDE 2-50mm DIA. PVC CONDUIT AND STUB OUTSIDE OF BASE.
5. ALL CONDUIT FITTINGS SHALL BE TO CANADIAN ELECTRICAL CODE.
6. CONTROLLER CABINET ANCHORS ARE ASSUMED TO BE 20mm DIA. x 150mm LONG A304 STAINLESS STEEL THREADED ROD, WITH APPROVED CHEMICAL ADHESIVE, INSTALLED IN ACCORDANCE WITH ANCHOR MANUFACTURERS GUIDELINES.
7. SUITABILITY OF ANCHORS IS TO BE CONFIRMED BY EQUIPMENT MANUFACTURER PRIOR TO INSTALLATION.
8. MAXIMIZE ANCHOR EDGE DISTANCES.
9. ALL DIMENSIONS IN MILLIMETERS.
10. REBAR TO CONFORM TO CAN/CSA G30.18-09 GRADE 400W DEFORMED BARS.

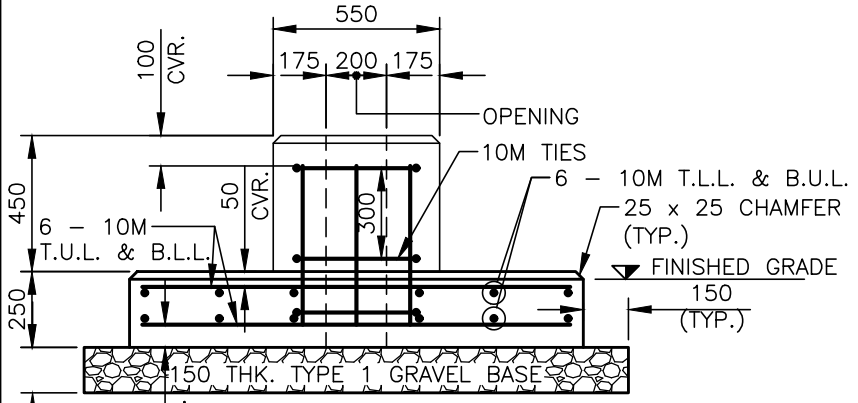

E1 ELEVATION
1:25

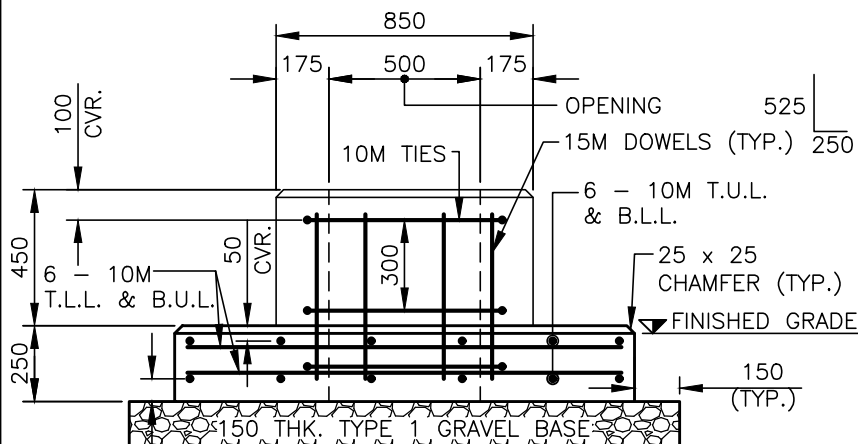

E2 ELEVATION
1:25

<h1>HALIFAX</h1>		
STANDARD DETAIL		
BASE MOUNTED TRAFFIC SIGNAL CONTROLLER CABINET		
DATE:	REFERENCE	APPROVED
2021		
SCALE:		FIG No.:
AS NOTED		HRM 175

NOTES:

1. CONCRETE 28 DAY COMPRESSIVE STRENGTH TO BE 35 MPa.
2. PROVIDE MIN. 50 COVER FOR ALL REBAR (UNLESS NOTED OTHERWISE).
3. PROVIDE GROUNDING FOR CONTROLLER CABINET.
4. IN ADDITION TO CONDUITS SPECIFIED ON EQUIPMENT DRAWINGS/SPECIFICATIONS, PROVIDE 2-50mm DIA. PVC CONDUIT AND GROUNDING CONDUIT FOR CONNECTION BETWEEN EQUIPMENT CHIMNEYS.
5. ALL CONDUIT FITTINGS SHALL BE TO CANADIAN ELECTRICAL CODE.
6. CONTROLLER CABINET ANCHORS ARE ASSUMED TO BE 20mm DIA. x 150mm LONG A304 STAINLESS STEEL THREADED ROD, WITH APPROVED CHEMICAL ADHESIVE, INSTALLED IN ACCORDANCE WITH ANCHOR MANUFACTURERS GUIDELINES.
7. BATTERY BACK-UP UNIT ANCHORS ARE ASSUMED TO BE 22mm DIA. x 150mm LONG A304 STAINLESS STEEL THREADED ROD, WITH APPROVED CHEMICAL ADHESIVE, INSTALLED IN ACCORDANCE WITH ANCHOR MANUFACTURERS GUIDELINES.
8. SUITABILITY OF ANCHORS IS TO BE CONFIRMED BY EQUIPMENT MANUFACTURER PRIOR TO INSTALLATION.
9. MAXIMIZE ANCHOR EDGE DISTANCES.
10. ALL DIMENSIONS IN MILLIMETERS.
11. REBAR TO CONFORM TO CAN/CSA G30.18-09 GRADE 400W DEFORMED BARS.

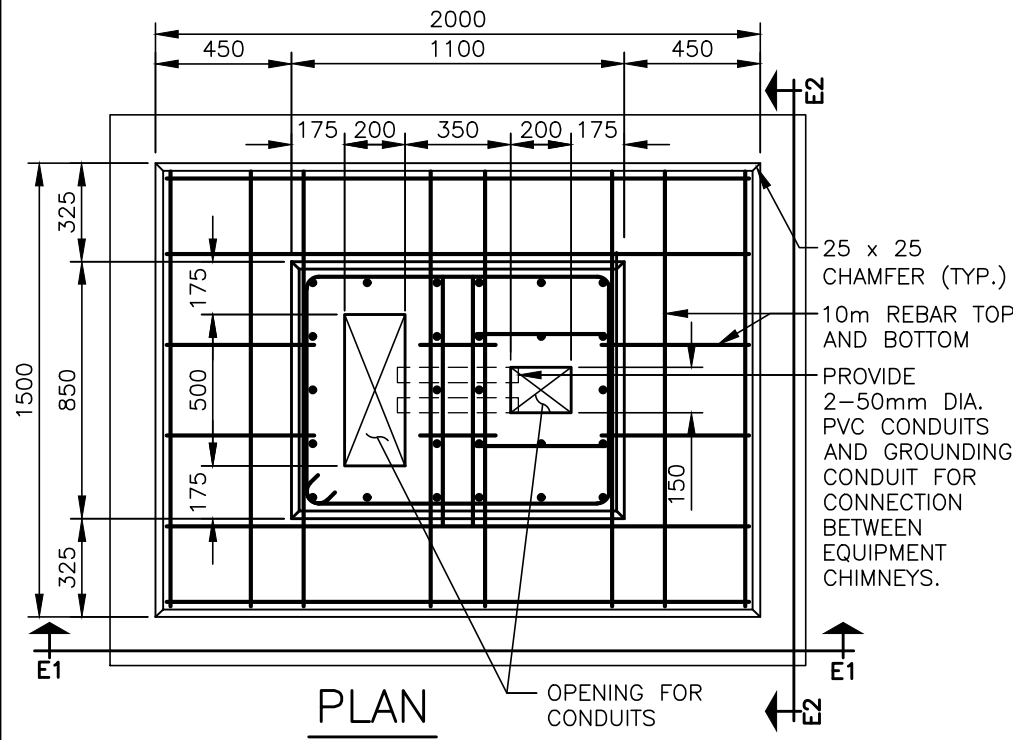

PLAN
1:25

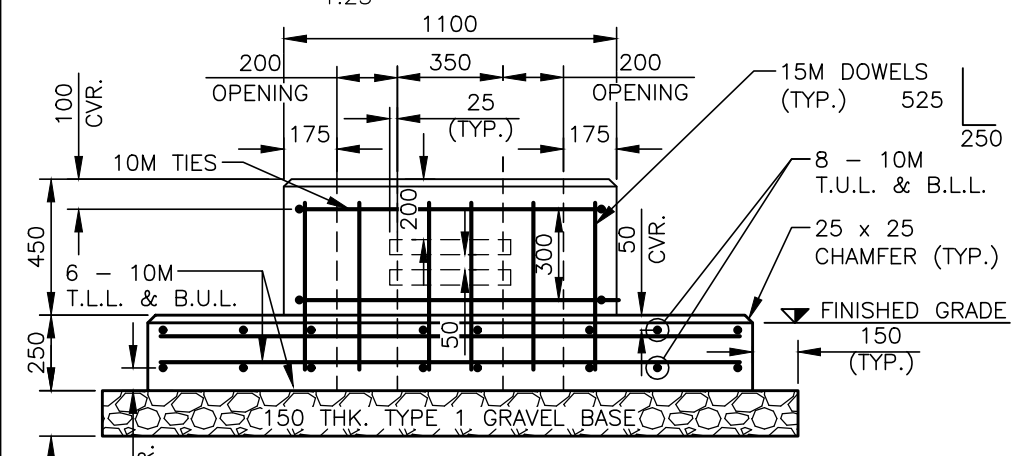

E1 ELEVATION
1:25

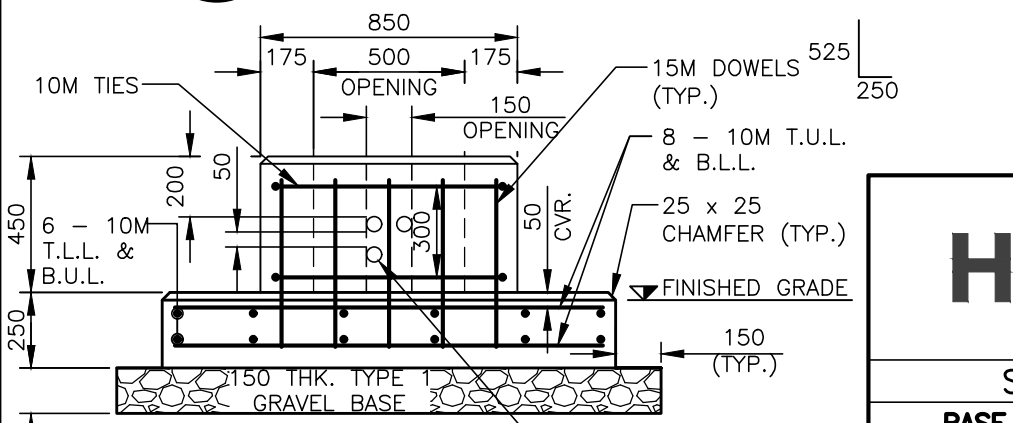

E2 ELEVATION
1:25

PROVIDE 2-50mm DIA. PVC CONDUITS AND GROUNDING CONDUIT FOR CONNECTION BETWEEN EQUIPMENT CHIMNEYS.

HALIFAX

STANDARD DETAIL

BASE MOUNTED TRAFFIC SIGNAL
CONTROLLER CABINET WITH BATTERY
BACK-UP UNIT

DATE:	REFERENCE	APPROVED
2021		
SCALE:		FIG No.:
AS NOTED		HRM 176

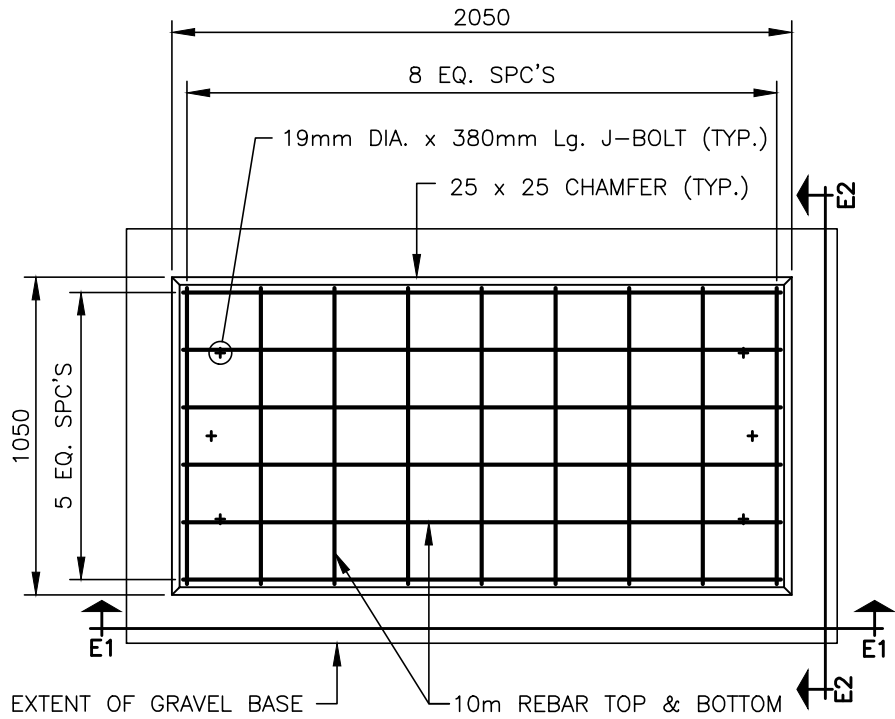

PLAN

1:25

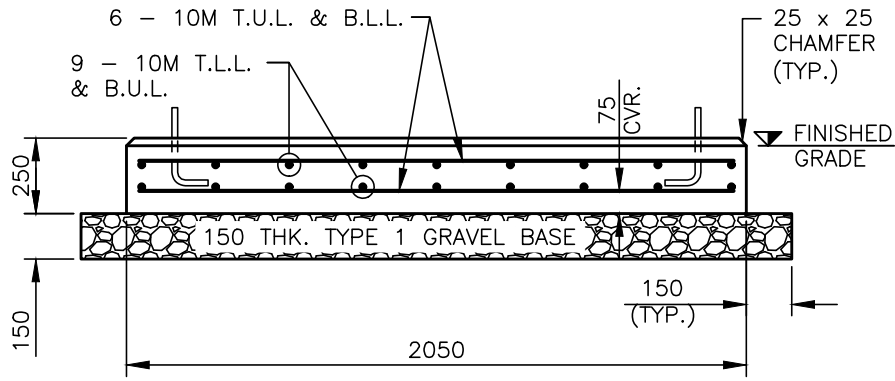

E1 ELEVATION

1:25

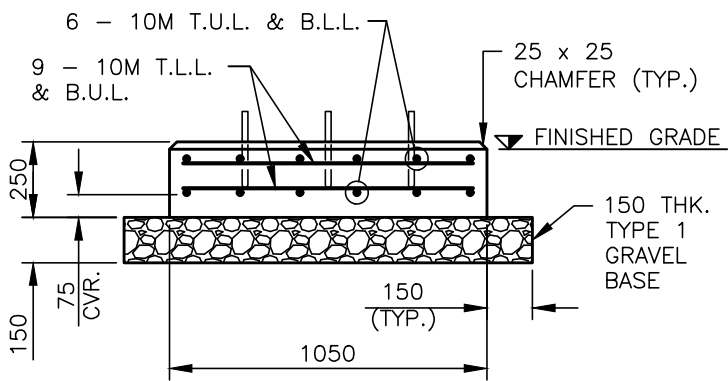

E2 ELEVATION

1:25

NOTES:

1. CONCRETE 28 DAY COMPRESSIVE STRENGTH TO BE 35 MPa.
2. PROVIDE MIN. 50mm COVER FOR ALL REBAR (UNLESS NOTED OTHERWISE).
3. PROVIDE GROUNDING PLATE FOR CABINET.
4. TYPICAL STREET LIGHT POWER ENCLOSURES ARE 610mm WIDE BY 1830mm LONG BY 1830mm HIGH. THE ENCLOSURE MUST BE CENTERED ON THE CONCRETE PAD AND THE CONDUIT LAYOUT MUST ALIGN WITH THE MOUNTING BACKBOARD INSIDE THE ENCLOSURE AS PER THE TYPICAL STREET LIGHT POWER ENCLOSURE "RED BOOK" DETAILS HRM 109-HRM 111.
5. ALL CONDUIT FITTINGS AND GROUNDING SHALL BE TO CANADIAN ELECTRICAL CODE.
6. CONTROLLER CABINET ANCHORS ARE ASSUMED TO BE 6-19mm DIA. x 380mm LONG A307 GALVANIZED STEEL J-BOLTS.
7. SUITABILITY OF ANCHORS IS TO BE CONFIRMED BY EQUIPMENT MANUFACTURER PRIOR TO INSTALLATION.
8. ALL DIMENSIONS IN MILLIMETERS.
9. REBAR TO CONFORM TO CAN/CSA G30.18-09 GRADE 400W DEFORMED BARS.
10. MAXIMUM CONDUIT DIAMETER = 150mm. PROVIDE AT LEAST 25mm CLEAR SPACE BETWEEN CONDUITS.
11. MAXIMUM NUMBER OF CONDUITS PER BASE = 10 x 150mm DIA. CONDUITS OR EQUIVALENT AREA OF SMALLER CONDUITS. (LOCALLY ADJUST REBAR SPACINGS IF NECESSARY).

<h1>HALIFAX</h1>		
STANDARD DETAIL		
STREET LIGHTING POWER ENCLOSURE BASE		
DATE:	REFERENCE	APPROVED
2021		
SCALE:		FIG No.:
AS NOTED		HRM 177

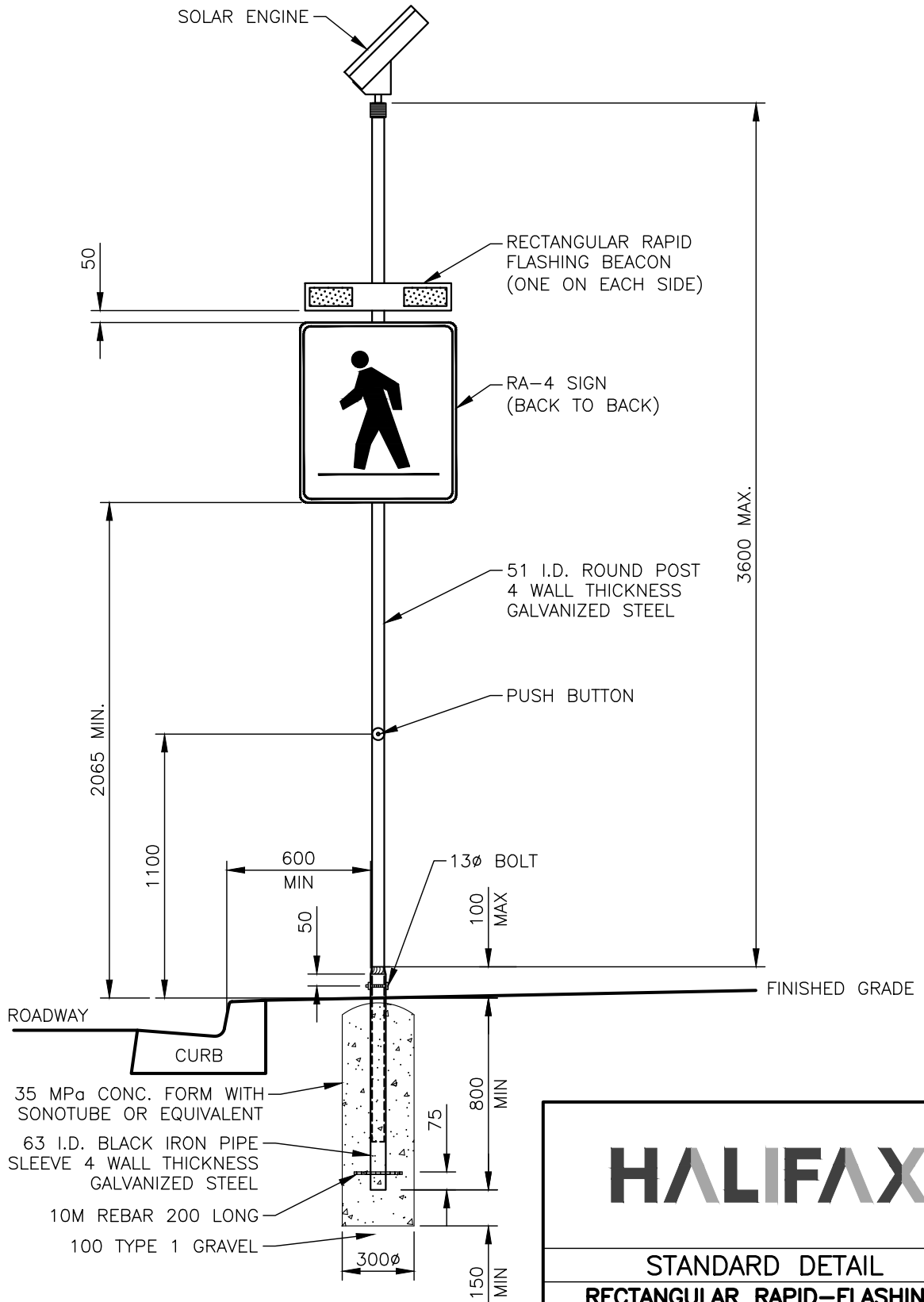

NOTE:

1. DIMENSIONS ARE IN MILLIMETRES.

HALIFAX

STANDARD DETAIL

RECTANGULAR RAPID-FLASHING BEACON SIGNAL CONFIGURATION (SOLAR ENGINE)

DATE:	2021	REFERENCE	APPROVED
SCALE:	1:25		FIG No.:
			HRM 180

PROPOSED SOIL GROUPINGS

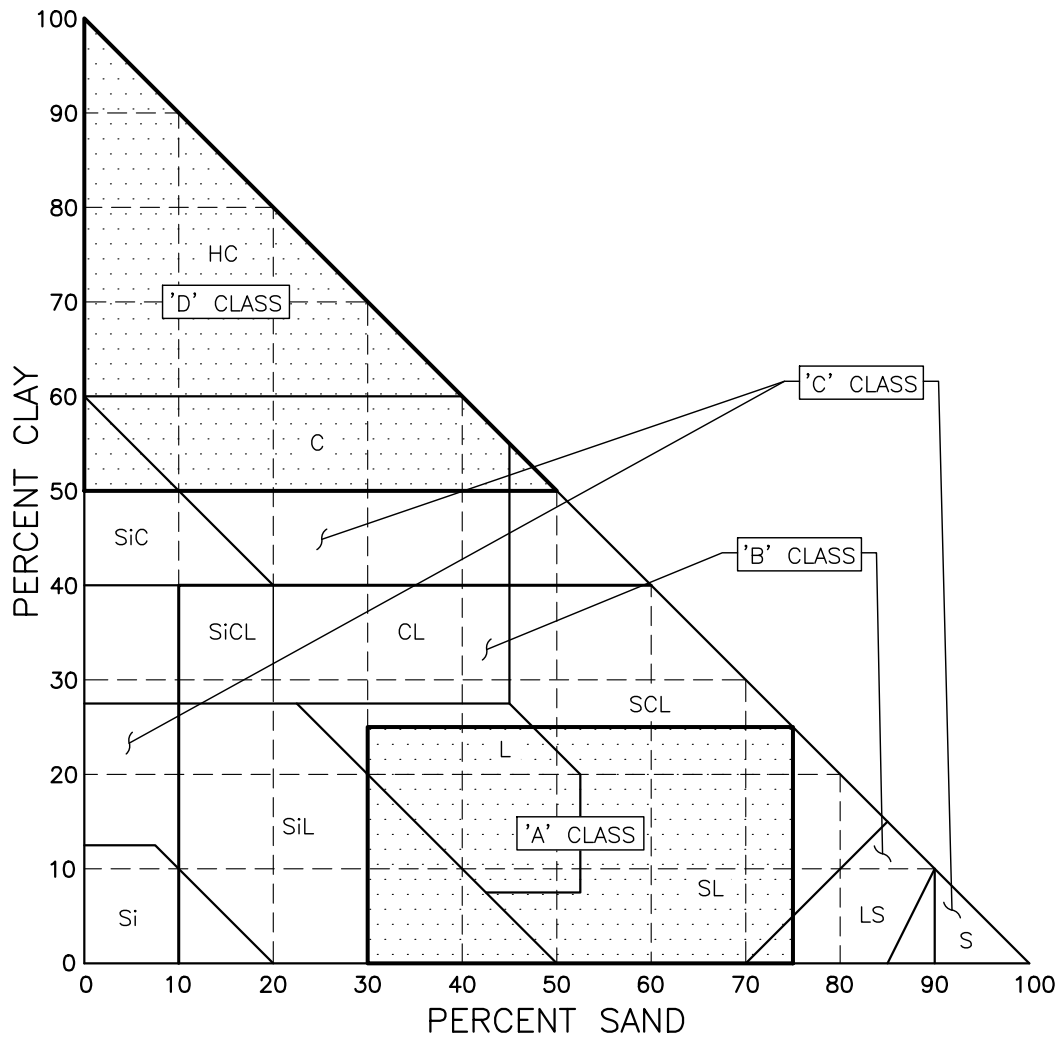

NOTES:

1. SOIL TEXTURE CLASSES. PERCENTAGES OF CLAY AND SAND IN THE MAIN TEXTURAL CLASSES OF SOIL; THE REMAINDER OF EACH CLASS IS SILT.

HALIFAX

STANDARD DETAIL

SOIL TEXTURE TRIANGLE

DATE:	2021	REFERENCE	APPROVED
SCALE:	NTS		FIG No.:
			HRM 181

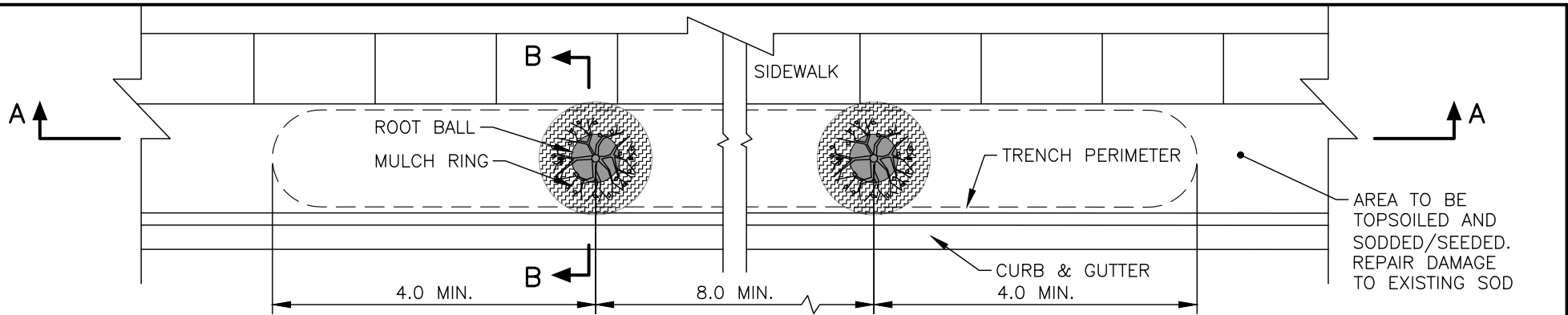

PLAN
SCALE 1:75

GALVANIZED GUY WIRE NO. 12 GAUGE (MIN.), WRAP GUY WIRE BACK ON ITSELF, ENDURE NO SHARP PROTRUSIONS (TYP.)

REFER TO SITE PLAN FOR SURFACE TREATMENT (TYP.)

TWO VERTICAL STAKES PER TREE:
 - MIN. 2.0m LENGTH T-BARS OR ROUND WOOD POSTS.
 - STAKES SET MIN. 600mm BELOW BASE OF ROOT BALL.
 - ALIGN STAKES WITH DIRECTION OF TRAFFIC.

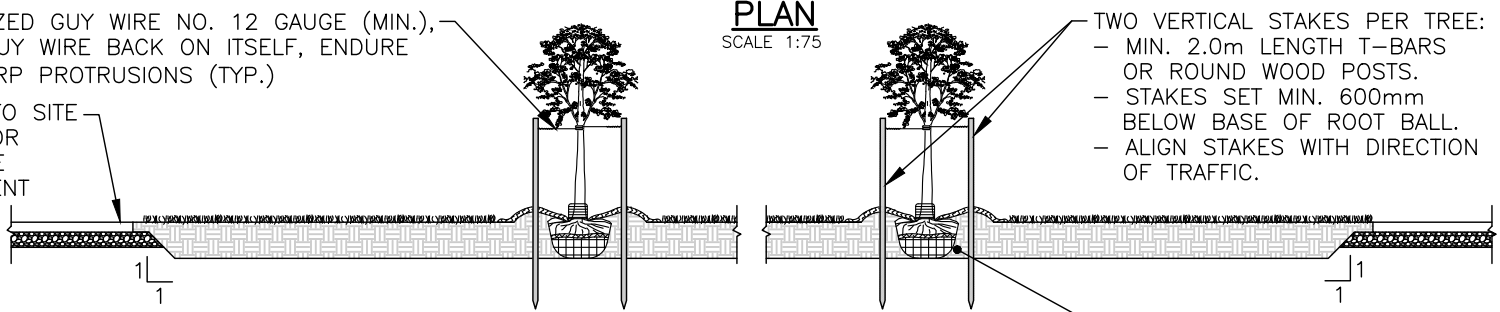

SECTION A-A
SCALE 1:75

TREE GUARD. ARBOGARD + AG9-4 OR APPROVED EQUAL

ROOT COLLAR 50mm ABOVE GRADE

FOLD OR REMOVE TOP 1/3 WIRE BASKET AND/OR BURLAP FROM ROOT BALL

FORM A 100mm HIGH SOIL RING TO DIRECT WATER TO ROOT BALL

150mm TOPSOIL

SCARIFY BOTTOM AND WALLS OF TRENCH BEFORE PLACING ROOT BALL

DECIDUOUS TREE
50-60mm CALIPER

PRUNE DEAD, BROKEN AND DISEASED TREE LIMBS

RUBBER HOSE, POSITION APPROX. AT 3/5 HEIGHT FOR ALL TREES

150mm DEPTH APPROVED MULCH

BACKFILL TRENCH WITH TOPSOIL, COMPACT JUST TO ENSURE STABILITY OF ROOT BALL

REPAIR ANY DAMAGED SEED/SOD TO HRM STANDARDS

SIDEWALK

EXISTING SOIL

SECTION B-B
SCALE 1:50

BACKFILL TRENCH WITH TOPSOIL, COMPACT TO MAXIMUM 85% SPD, ENSURE STABILITY OF ROOTBALL.

NOTES:

1. SOAK THE ROOTBALL AND BACKFILL AREA WITH 40 LITRES OF WATER AFTER PLANTING
2. ROOT BALL MIN. SIZE AS PER CNLA STANDARDS FOR NURSERY STOCK
3. MINIMUM TRENCH LENGTH: 8m PER TREE UNLESS APPROVED BY URBAN FORESTER

HALIFAX

STANDARD DETAIL

TREE PLANTING
IN SOD BOULEVARD

DATE:	2021	REFERENCE	APPROVED
SCALE:	AS NOTED	FIG No.:	HRM 182

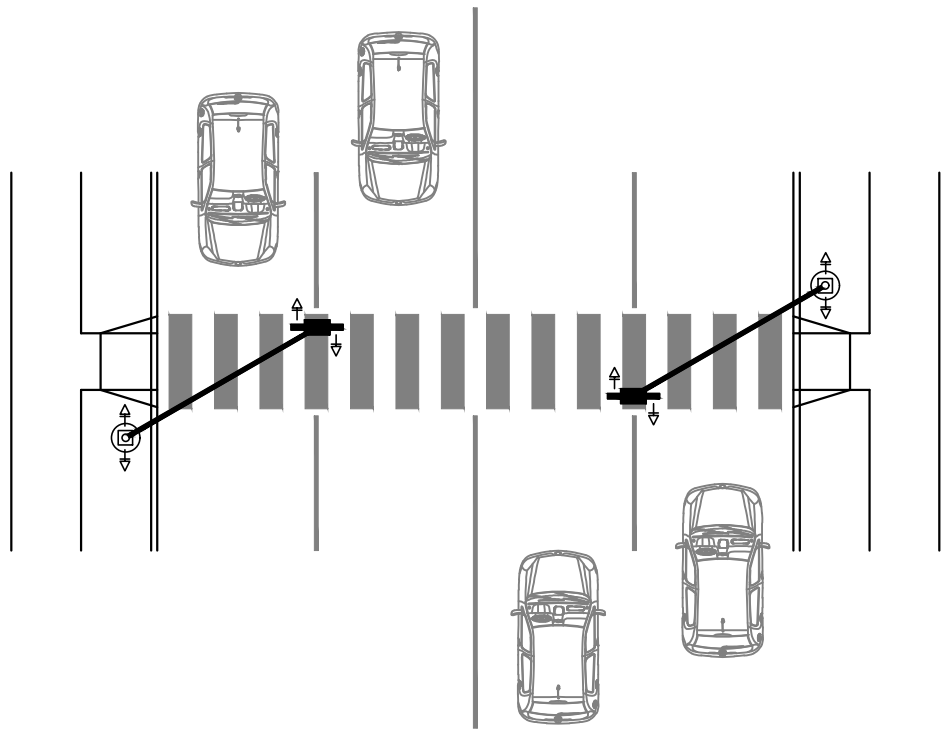

PLAN VIEW

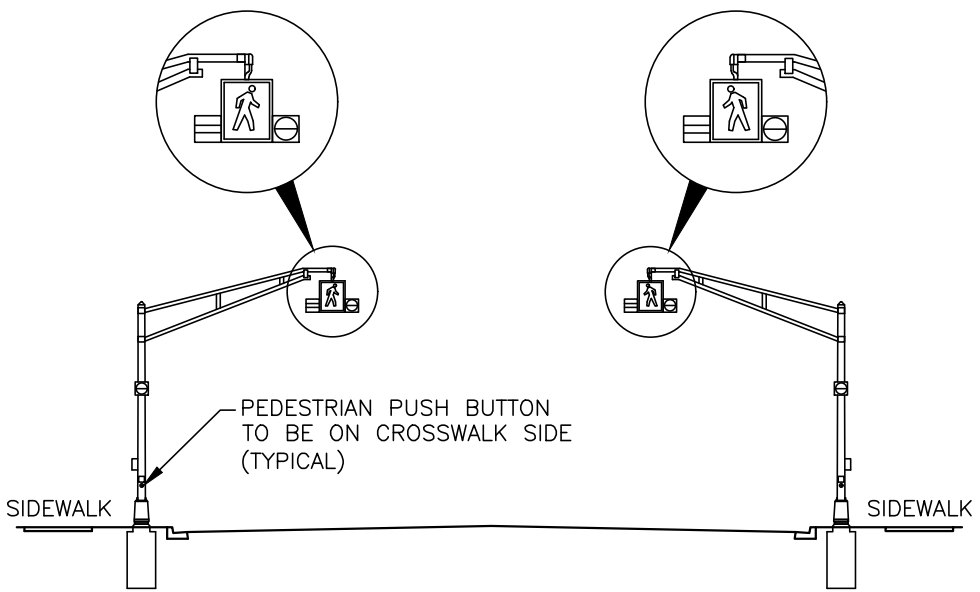

ELEVATION VIEW

NOTE:
 SEE RED BOOK STANDARD DETAIL
 "ALUMINUM POLE RA-5 SIGNAL
 CONFIGURATION"

HALIFAX		
STANDARD DETAIL		
RA-5 CROSSING		
DATE:	2021	REFERENCE
SCALE:	NTS	APPROVED
		FIG No.: HRM 183

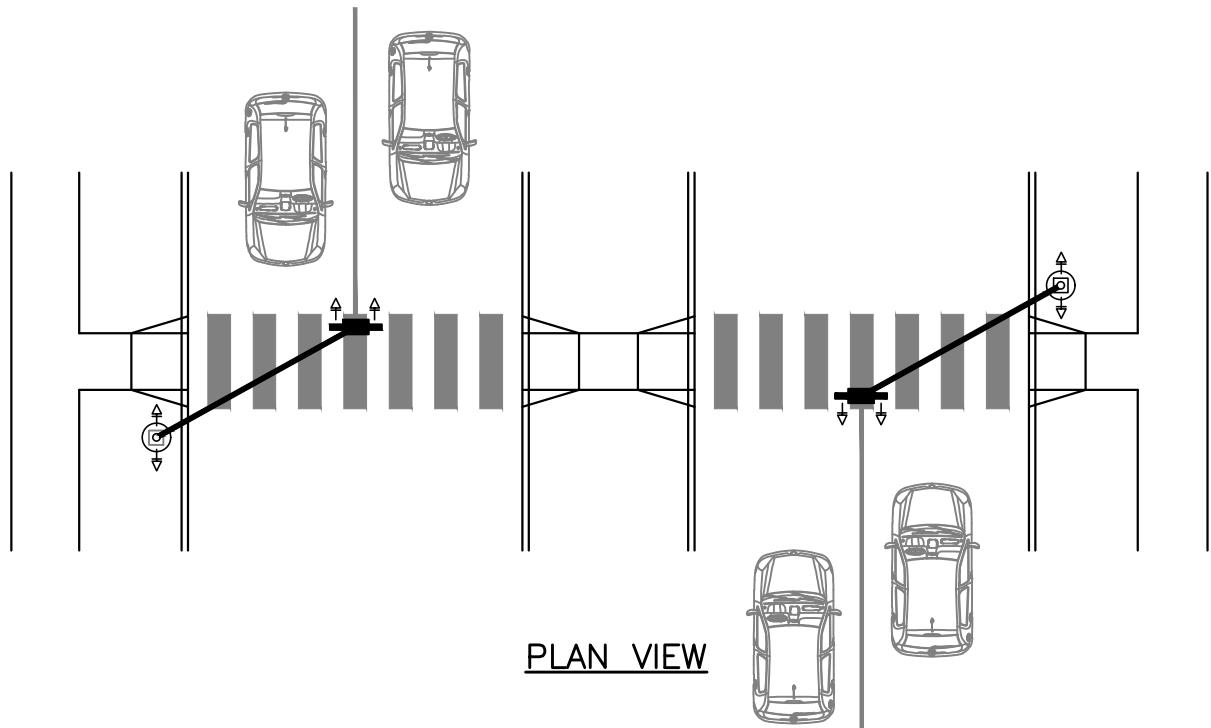

PLAN VIEW

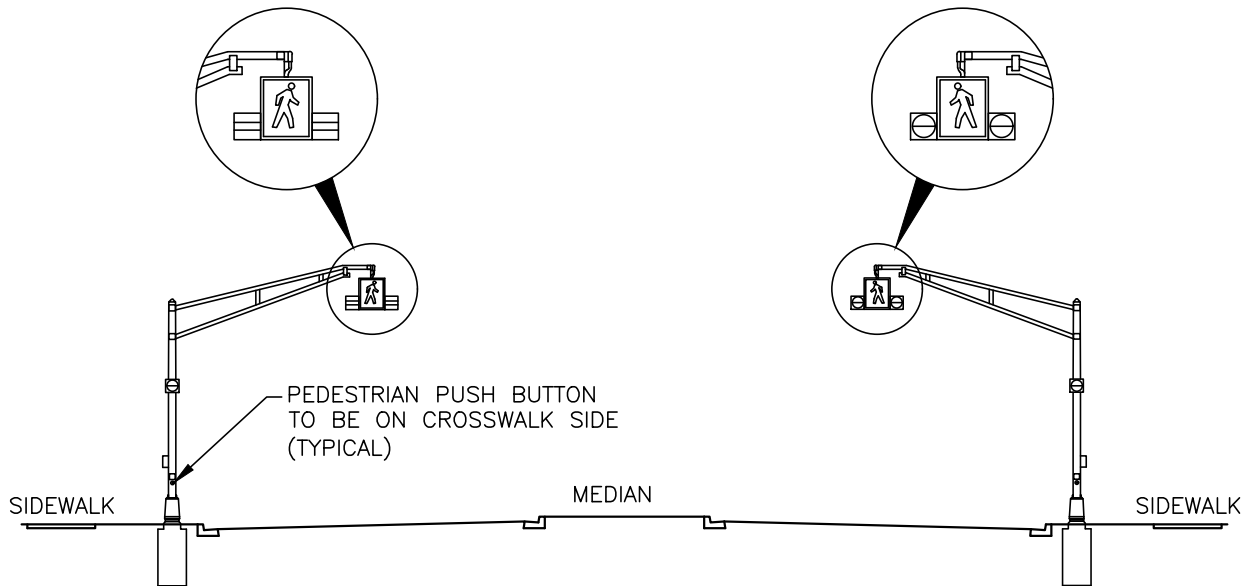

ELEVATION VIEW

NOTE:

SEE RED BOOK STANDARD DETAIL
"ALUMINUM POLE RA-5 SIGNAL
CONFIGURATION"

HALIFAX

STANDARD DETAIL
RA-5 CROSSING
(WITH CENTRE MEDIAN)

DATE:	2021	REFERENCE	APPROVED
SCALE:	NTS		FIG No.: HRM 184

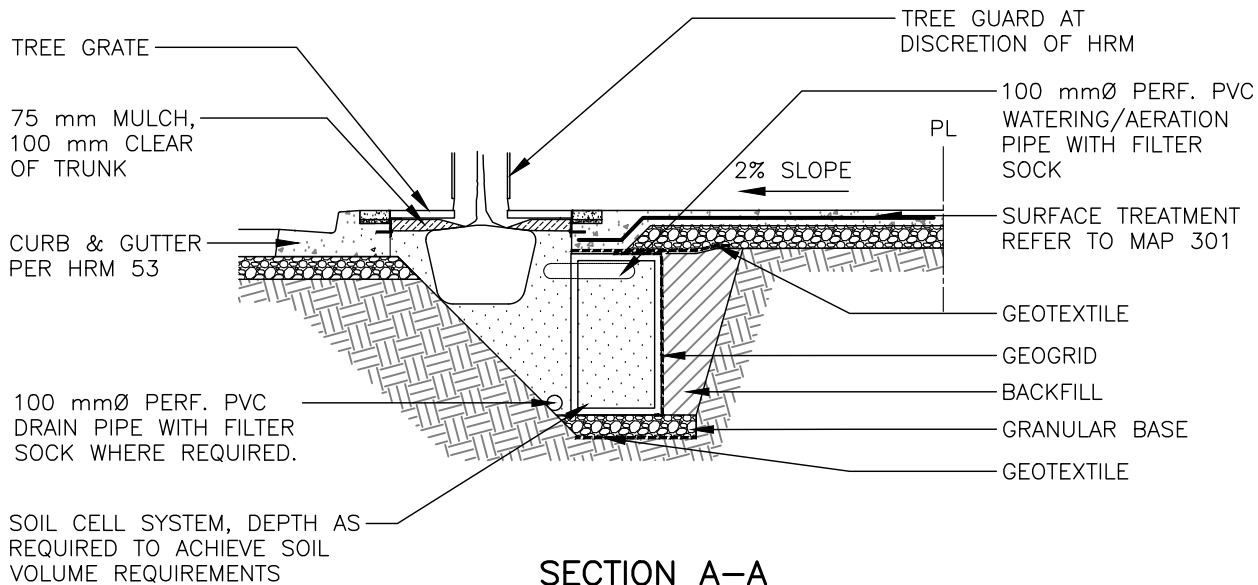

SECTION A-A
SCALE: 1:50

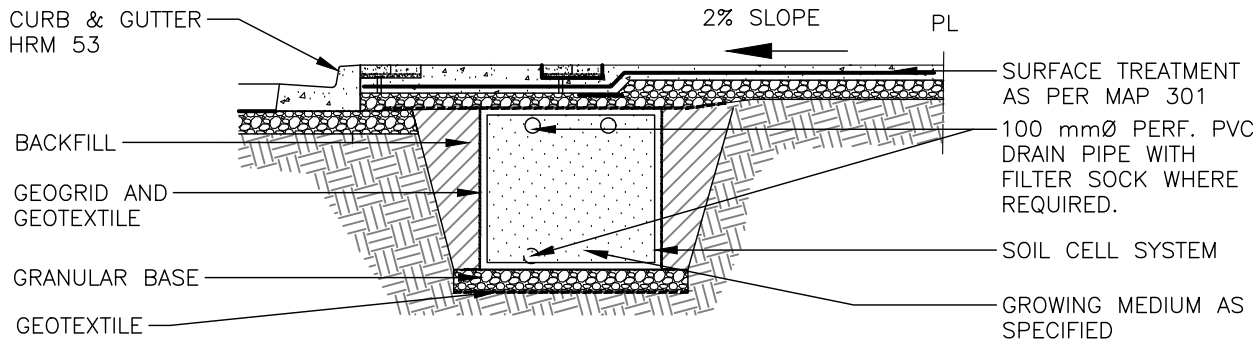

SECTION B-B
SCALE: 1:50

NOTES:

1. TREE GRATE PER HRM DETAIL 187
2. TREE GUARD TO BE INSTALLED AT DISCRETION OF HRM
3. WORK WITHIN 2 m OF UTILITY POLES REQUIRES NON-DESTRUCTIVE HOLDING PLANS STAMPED BY AN ENGINEER LICENSED TO WORK IN NS
4. SOIL CELL SYSTEM, GEOTEXTILE, GEOGRID, AND GRANULAR BASE TO BE INSTALLED AS PER MFR SPEC
5. REFER TO SECTION A: DESIGN GUIDELINES, FOR SOIL VOLUME REQUIREMENTS

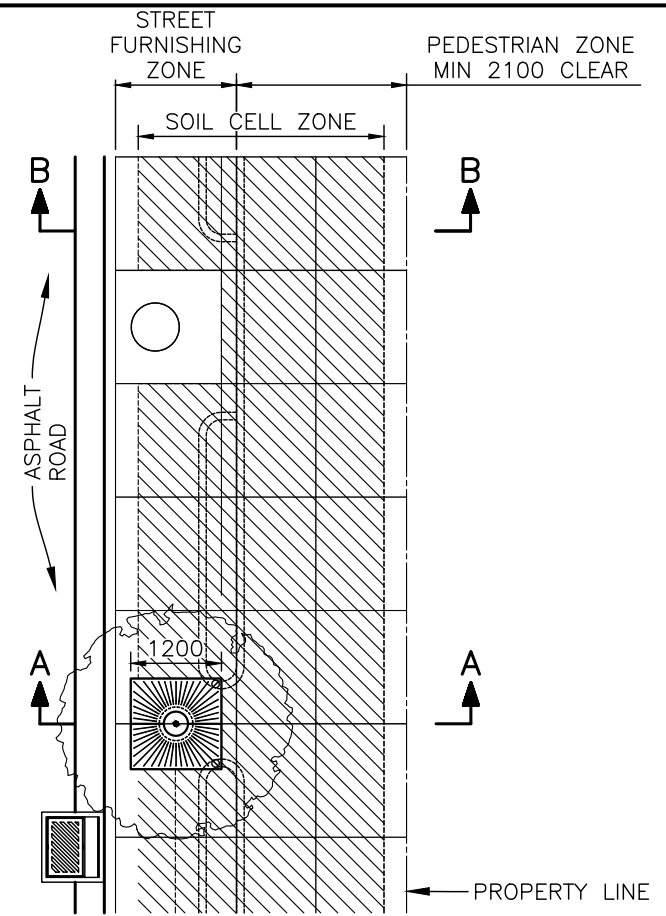

PLAN
SCALE: 1:100

HALIFAX

STANDARD DETAIL

TREE IN HARDSCAPE WITH SOIL CELLS AND TREE GRATE

DATE:	2021	REFERENCE	APPROVED
SCALE:	AS NOTED		FIG No.:
			HRM 186

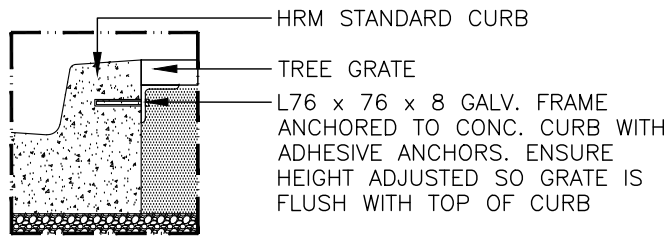

TREE GRATE AT EXIST. CURB

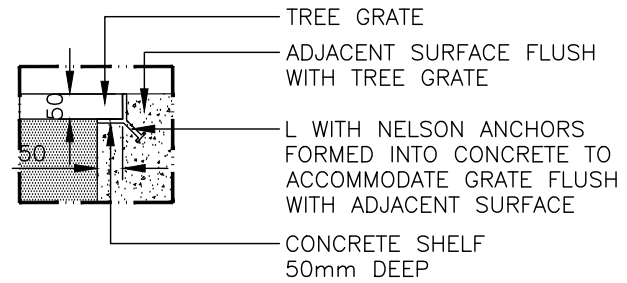

TREE GRATE AT PROP. CAST-IN-PLACE CONCRETE

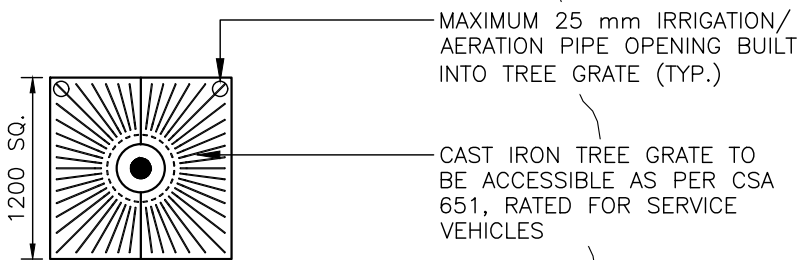

ACCESSIBLE TREE GRATE

SCALE: 1:50

HALIFAX

STANDARD DETAIL

TREE GRATE DETAILS

DATE:	2021	REFERENCE	APPROVED
SCALE:	1:15		FIG No.: HRM 187

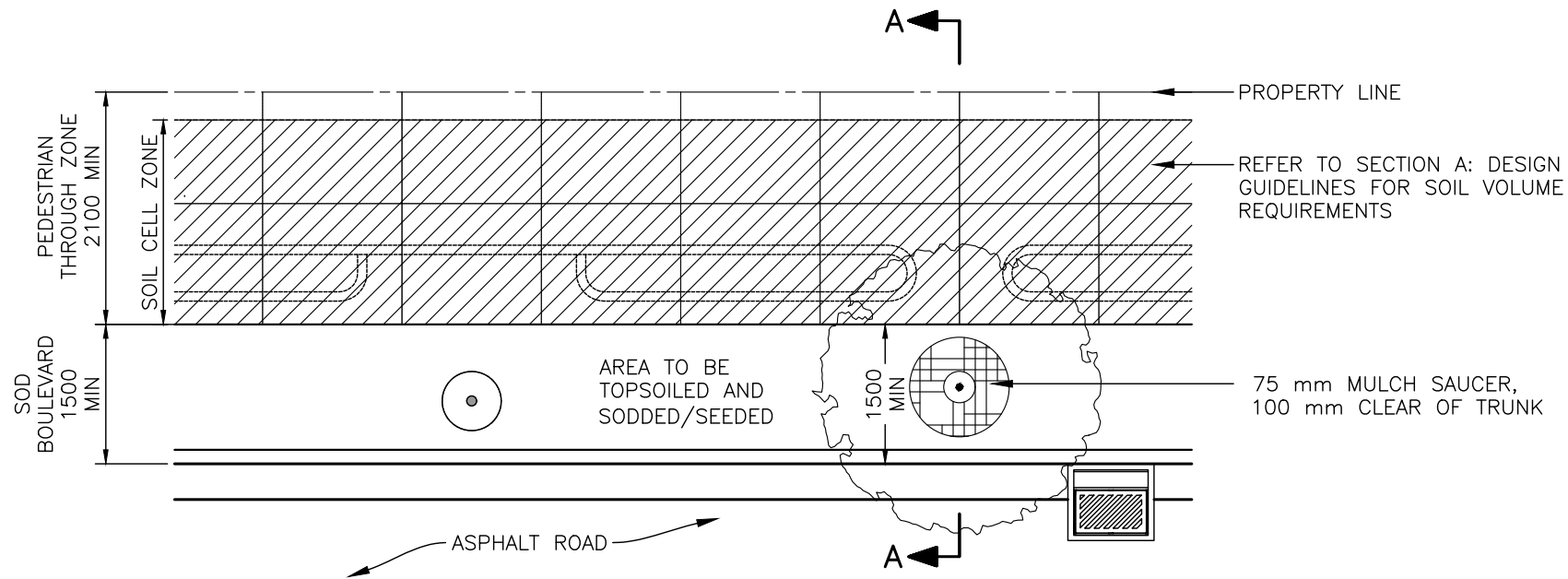

PLAN
SCALE 1:75

NOTES:

1. WORK WITHIN 2 m OF UTILITY POLES REQUIRES NON-DESTRUCTIVE HOLDING PLANS STAMPED BY AN ENGINEER LICENSED TO WORK IN NS
2. SOIL CELL SYSTEM, GEOTEXTILE, GEOGRID, AND GRANULAR BASE TO BE INSTALLED AS PER MFR SPEC
3. REFER TO SECTION A: DESIGN GUIDELINES, FOR SOIL VOLUME REQUIREMENTS.

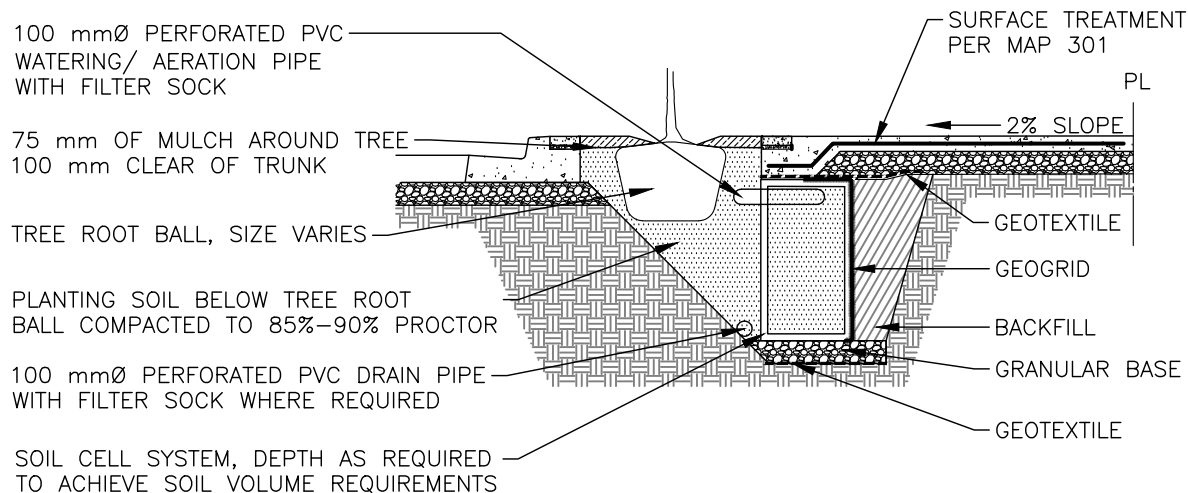

SECTION A-A
SCALE 1:50

HALIFAX

STANDARD DETAIL

TREE IN SOD BOULEVARD
WITH SOIL CELLS

DATE: 2021	REFERENCE	APPROVED
SCALE: AS NOTED		FIG No.: HRM 188

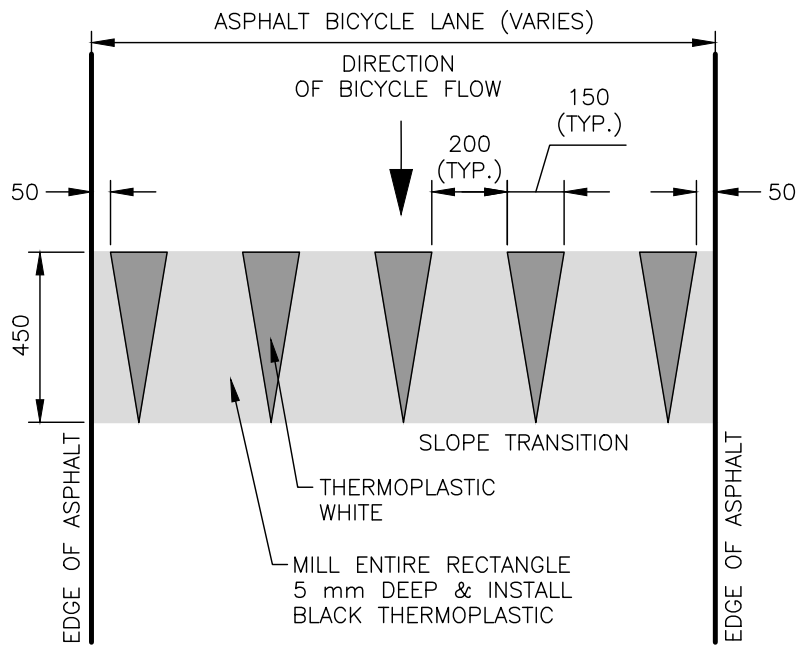

NOTES:

- TO IDENTIFY SLOPE ARROWS POINT UP AND ONLY ON LEADING EDGE.
- TO IDENTIFY YIELD CONDITION ARROWS POINT TOWARD YIELDING VEHICLE (BIKE).

SHARKS TEETH TRIANGLES

SCALE 1:20

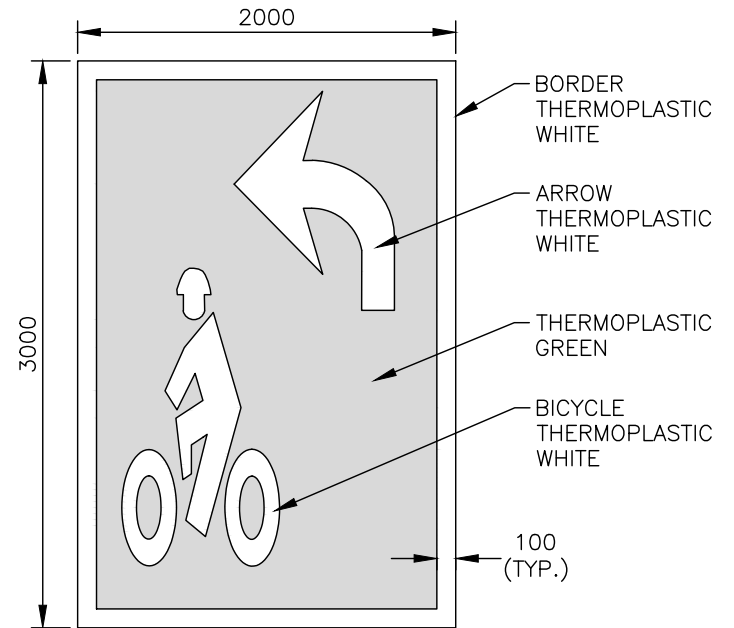

2 STAGE BICYCLE LEFT TURN BOX

SCALE 1:40

NOTES:

1. ALL DIMENSIONS SHOWN ARE IN MILLIMETRES.
2. FOR ALL THERMOPLASTIC PAVEMENT MARKINGS, CONTRACTOR TO MILL 5 mm DEEP BEFORE APPLYING THERMOPLASTIC SHEETS.

HALIFAX		
STANDARD DETAIL		
BICYCLE PAVEMENT MARKINGS		
DATE:	REFERENCE	APPROVED
2021		
SCALE:		FIG No.:
AS NOTED		HRM 189

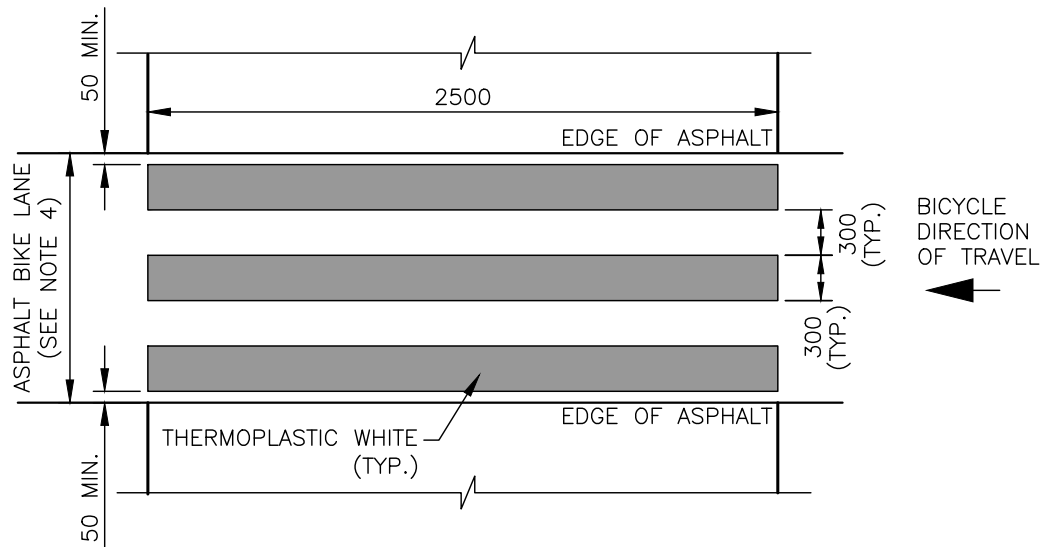
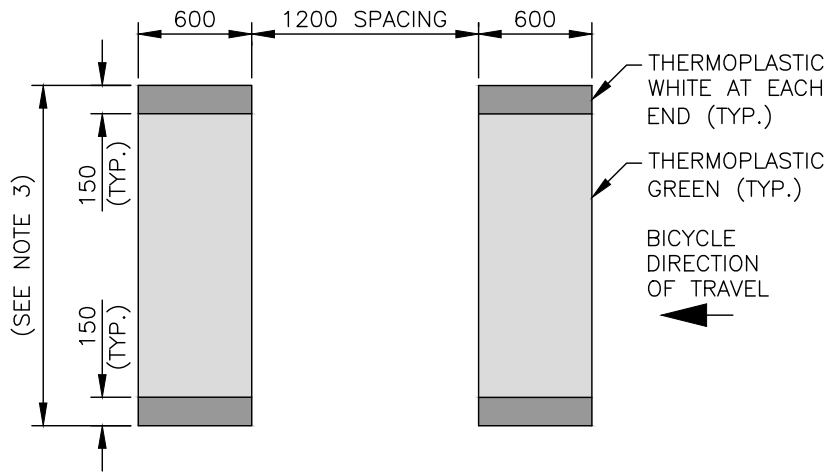

VEHICLE/BICYCLE ZEBRA CONFLICT MARKING

PEDESTRIAN CROSSING AT BIKE LANE

NOTES

1. ALL DIMENSIONS SHOWN ARE IN MILLIMETRES.
2. FOR ALL THERMOPLASTIC PAVEMENT MARKINGS, CONTRACTOR TO MILL 5 mm DEEP BEFORE APPLYING THERMOPLASTIC SHEETS.
3. CONFLICT MARKING WIDTH TO MATCH WIDTH OF BIKE LANE AND BUFFER.
4. PEDESTRIAN CONFLICT MARKING WIDTH TO MATCH WIDTH OF BIKE LANE.

HALIFAX

STANDARD DETAIL

BICYCLE LANE CONFLICT MARKINGS

DATE:	2021	REFERENCE	APPROVED
SCALE:	NTS		FIG No.: HRM 190