



DRC Meeting
Dennis Building
and Barrington &
George Site

17 Dec 2020

fathom





“Heritage and development are not mutually exclusive. Innovative and creative developers really see the potential of buildings like the Dennis Building.”

CBC News, 2014



Agenda

- 01 Introduction
- 02 Design
- 03 Requested Variances
- 04 Moving Forward

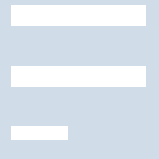

01 Introduction



A longstanding missing piece of the urban fabric of Barrington street. Fathom and Dexel seek to generate a design that repairs this fabric with a well articulated human scale streetscape rich in history and culture.



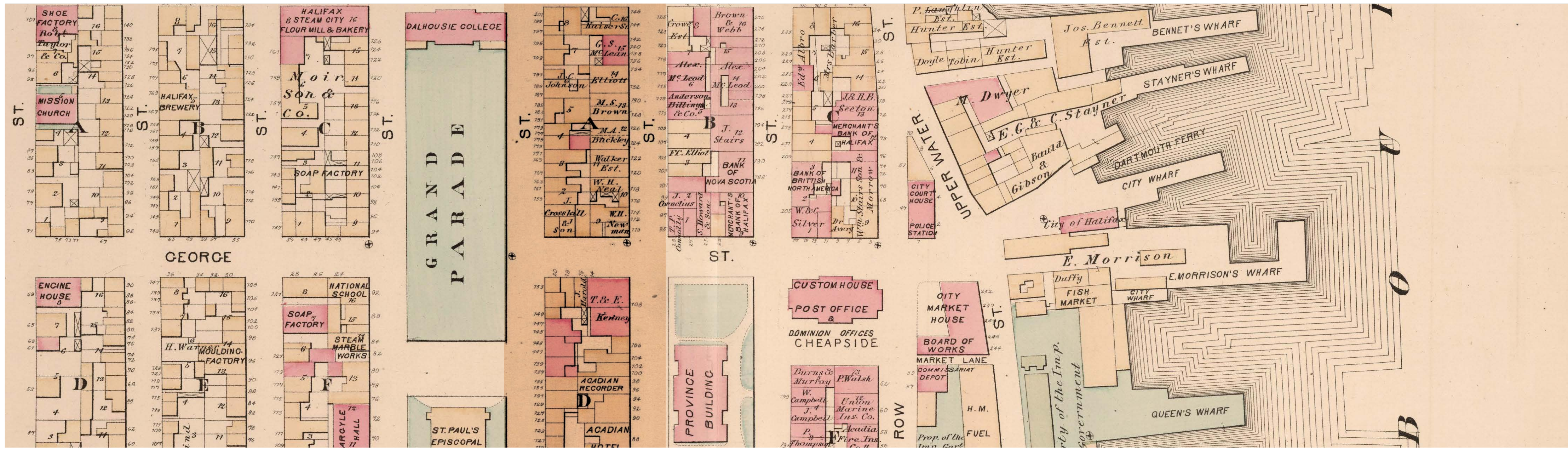

Barrington Street



Granville Street



fathom

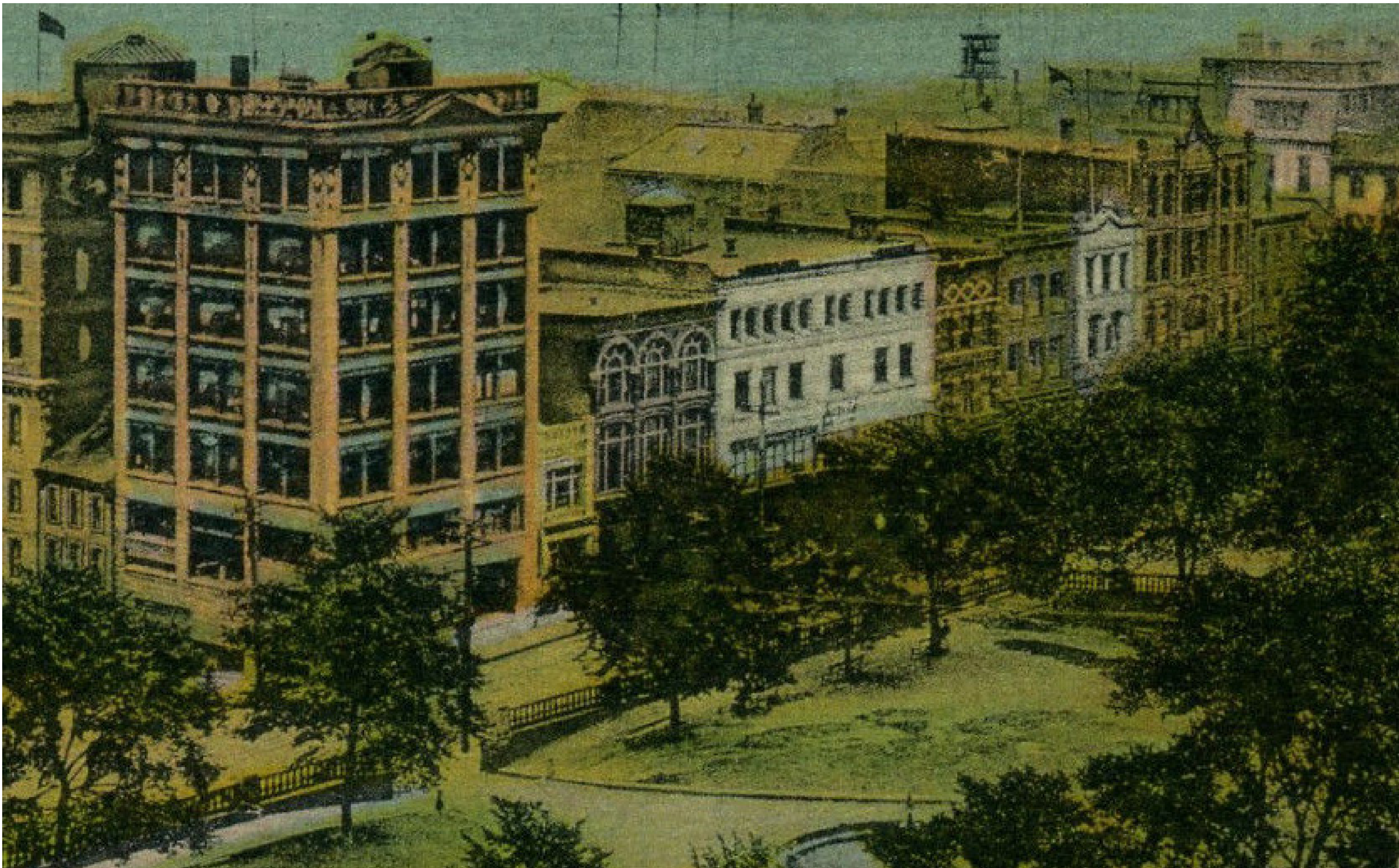



CRAGG BROS. CO., Ltd.

— HALIFAX, N. S. —

“THE CUTLERY HOUSE OF HALIFAX”

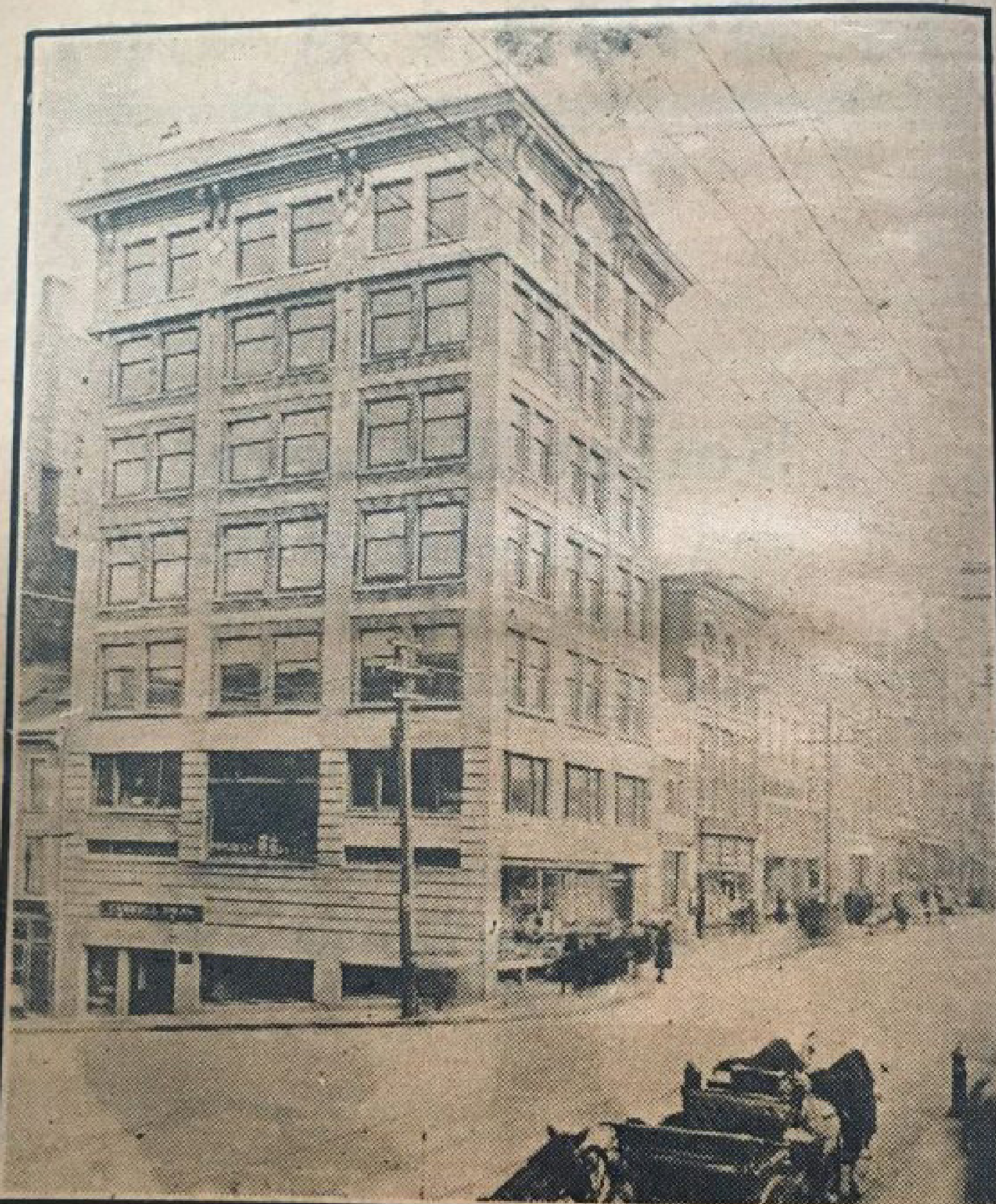

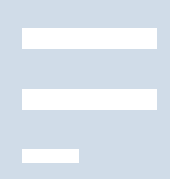

fathom



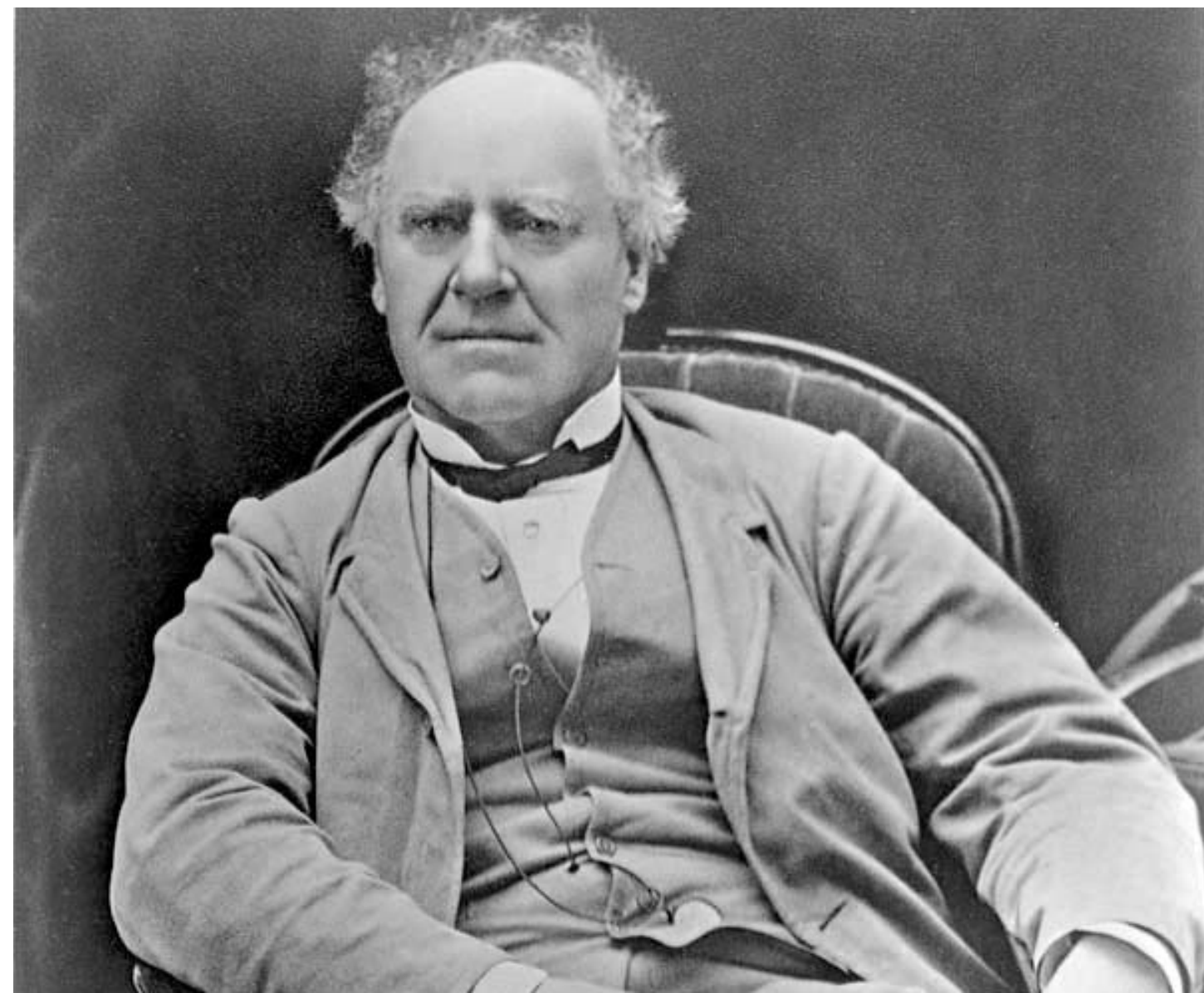

Early journalism

“Holland was able to present some innovative features in the *Acadian Recorder*. In February 1817 it became the first paper to print the debates of the assembly on a regular basis..”

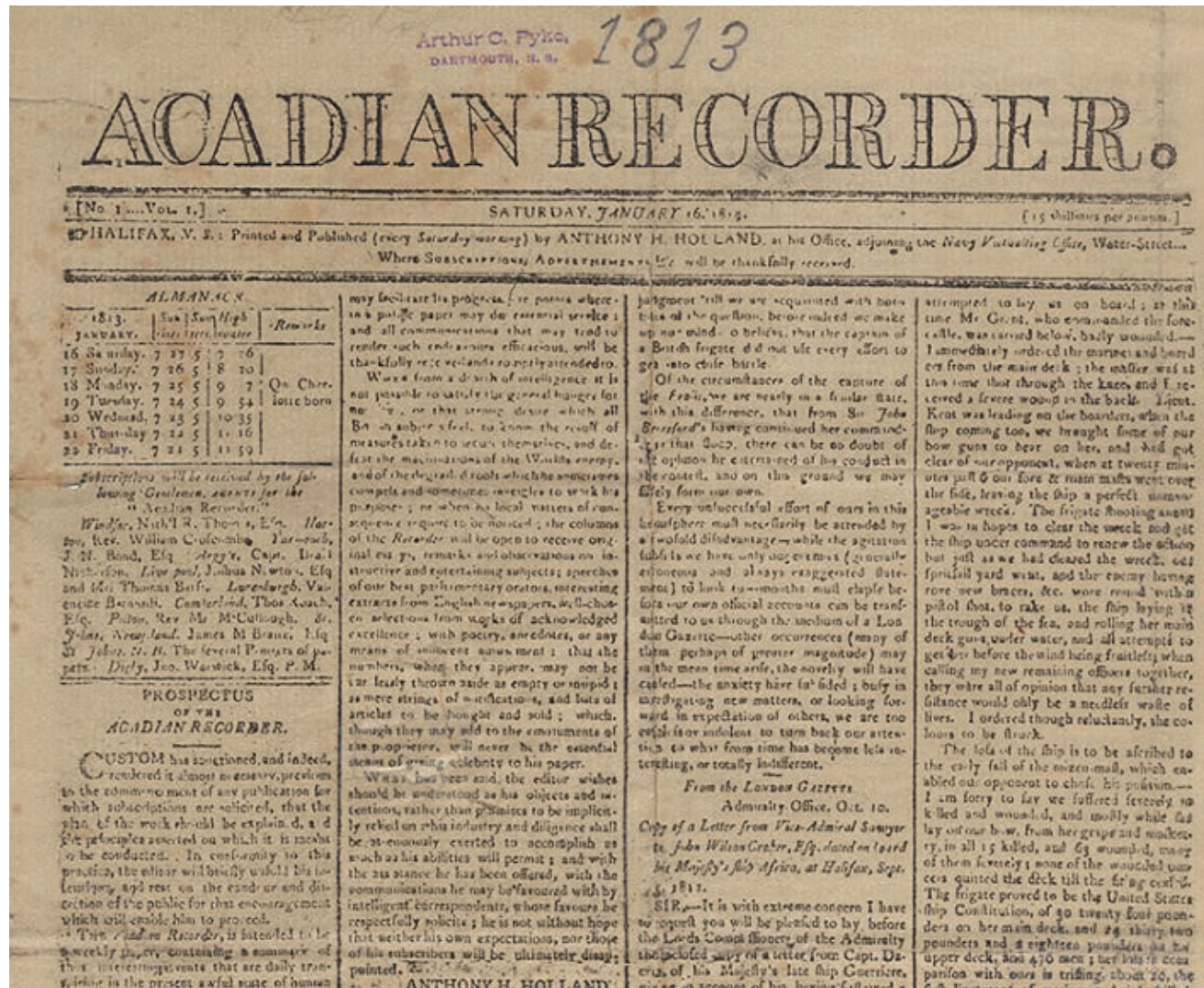

Key newspapers

Acadian Recorder, Halifax Herald, The Chronicle Herald

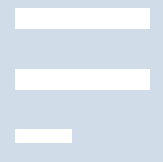

02 Design



Our team used the rich architectural and cultural history of the site to create a clear distinction between existing and contemporary architecture. The new architecture honoring the past without becomming a falsefied recreation of what was lost.



fathom





fathom



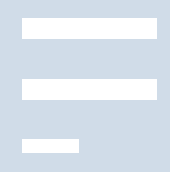

fathom





fathom



Barrington Street



fathom



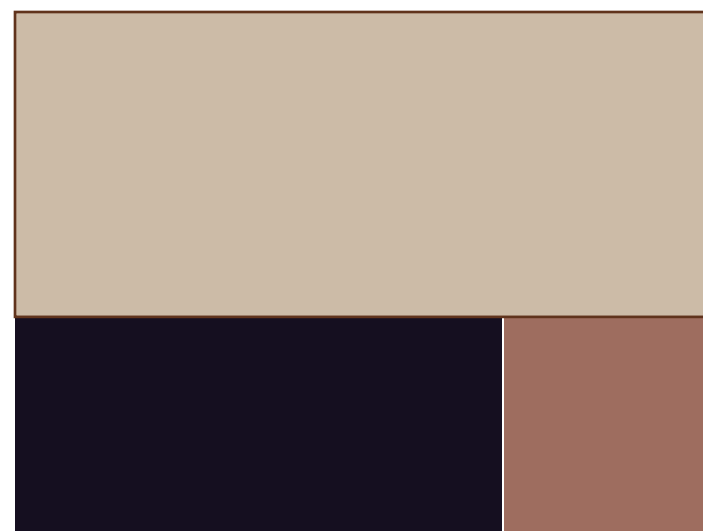

Brick / Cast Iron

Acadian Recorder
Existing Material Palette
of brick and cast iron to
be restored and cleaned
as required.



Granite / Copper

Dennis building existing
material Palette. Granite,
Copper, and Brick. to be
restored and cleaned as
required



Muntz Metal

Metal Alloy panels
will patina and age
with the building.



Masonry

Manufactured
sandstone as a
human scale light
toned material.

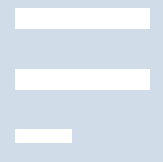

03 Requested Variances



Variance Summary



Variance Two: Streetwall Width

- Granville street perspective rendering.
- Historic details and returns are retained and articulated.
- Building elevations indicating width of streetwall reveals to highlight historic facade elements.



Variance Four: Land Uses at Grade

- Rendering at George Street and Granville Street
- Rendering of Granville Street
- Diagram of Granville Street showing streetwall ground floor height
- Diagram of Barrington and George Street corner showing streetwall ground floor height

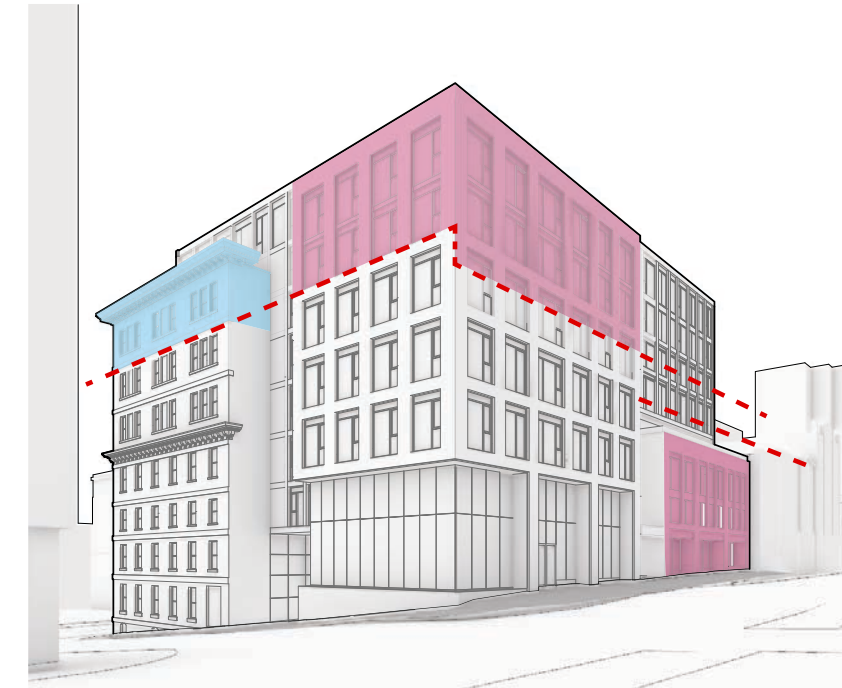

Variance One: Streetwall Height

- Building massing with requested streetwall height variance.
- i. Consistency with Downtown Halifax Schedule S-1 Design Manual
- ii. Transitional Block
- iii. Build Heritage & Urban Character



Variance Three: Maximum Height

- Rendering of Barrington and George Street corner
- Diagram showing floor levels of Dennis Building relative to new construction
- George Street elevation indicating the floor heights in addition are set be Dennis building existing floors
- Building cross-section showing integration of floor heights



Variance Five: Streetline Setback

- Granville street perspective rendering.
- Historic details and returns are retained and articulated.
- Building elevations indicating width of streetwall reveals to highlight historic facade elements.



Variance One: Streetwall height

The variance request is based on the following three rationales;

- i. Consistency with Downtown Halifax Schedule S-1 Design Manual
- ii. Transitional Block
- iii. Built Heritage / Urban Character



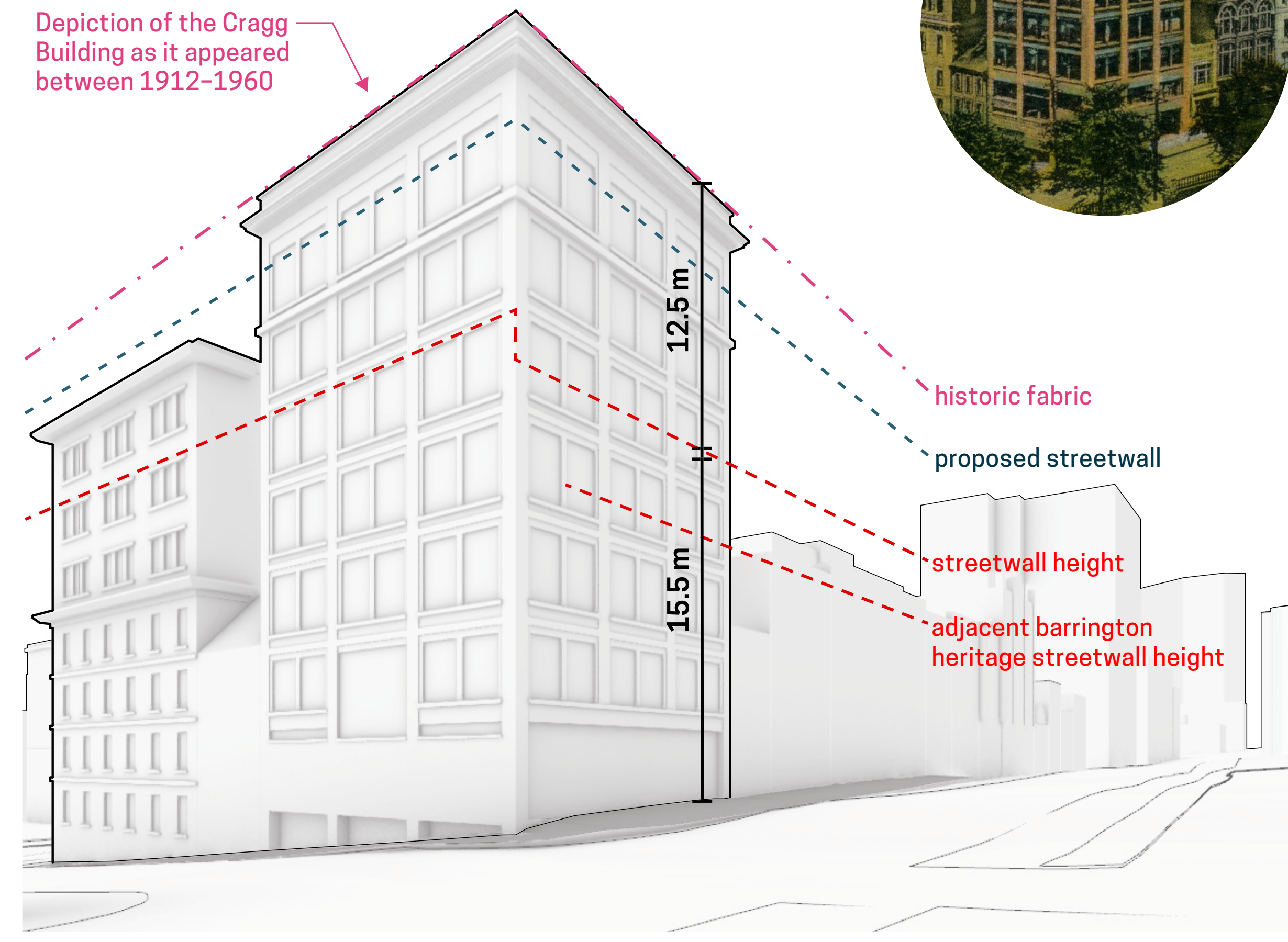
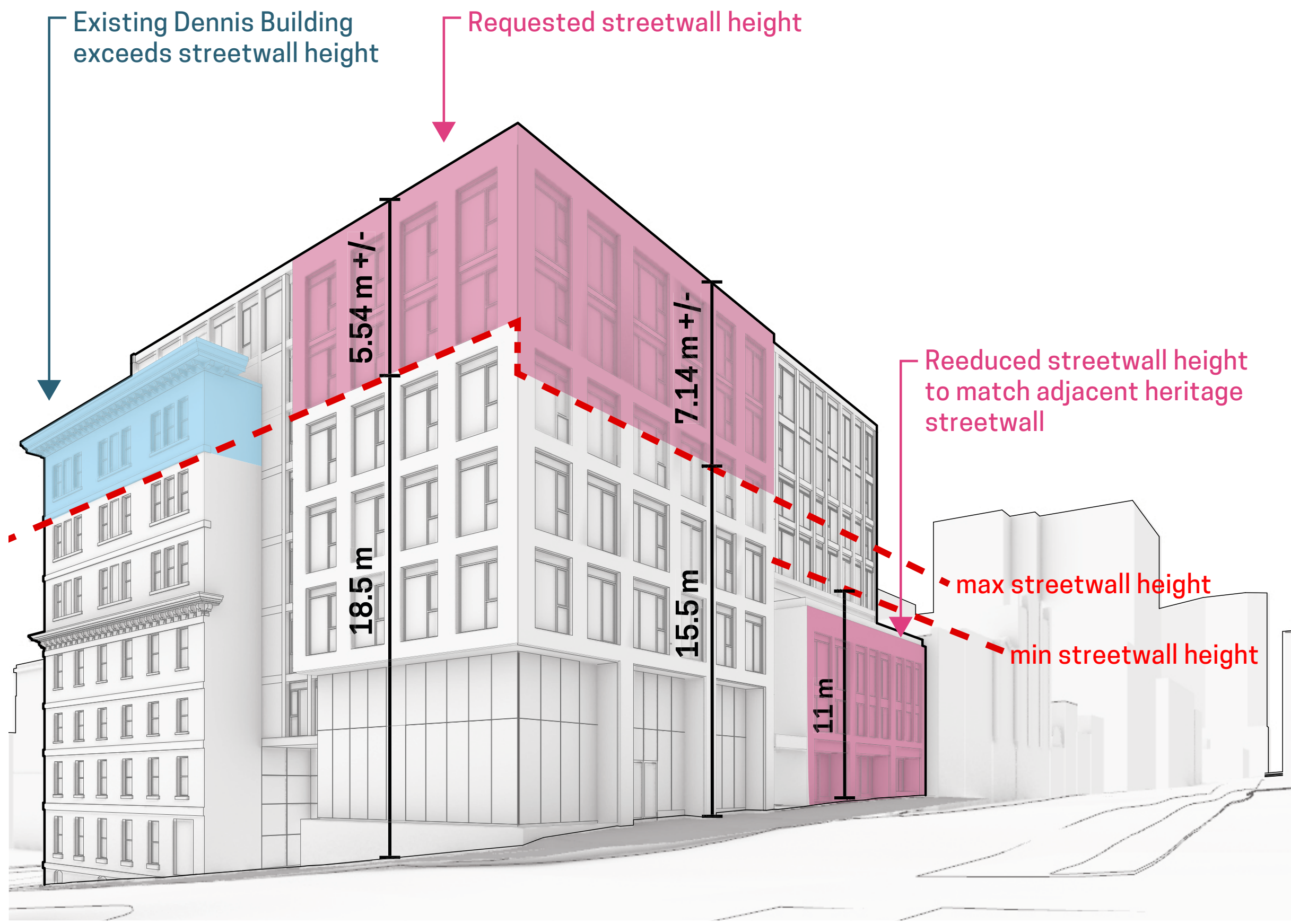

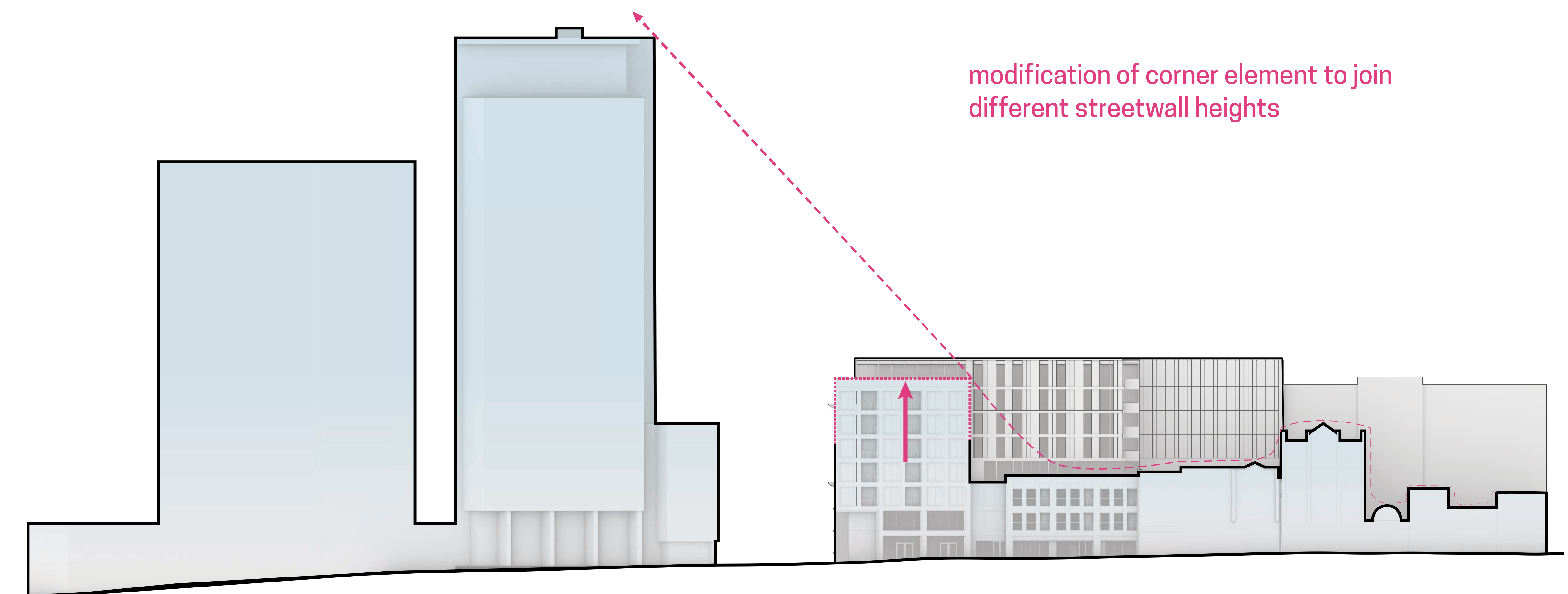

modification of corner element to join
different streetwall heights





Variance Two: Streetwall Width

The variance request is based on the following two rationales;

- i. Consistency with Downtown Halifax Schedule S-1 Design Manual
- ii. Built Heritage / Urban Character





Variance Five: Streetline setback

The variance request is based on the following two rationales;

- i. Consistency with Downtown Halifax Schedule S-1 Design Manual
- ii. Built Heritage / Urban Character



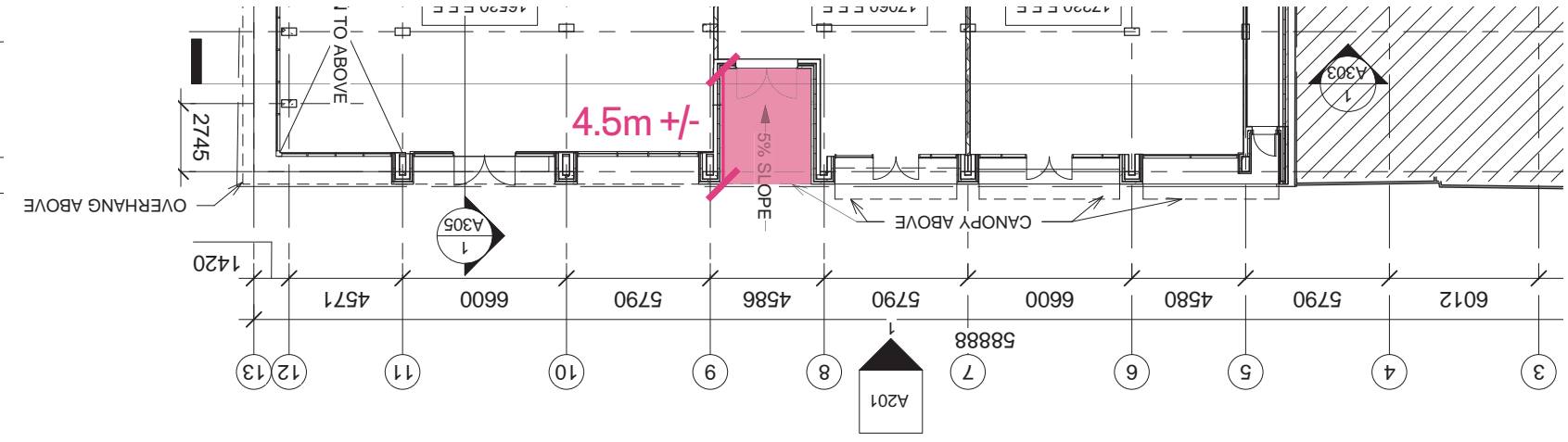
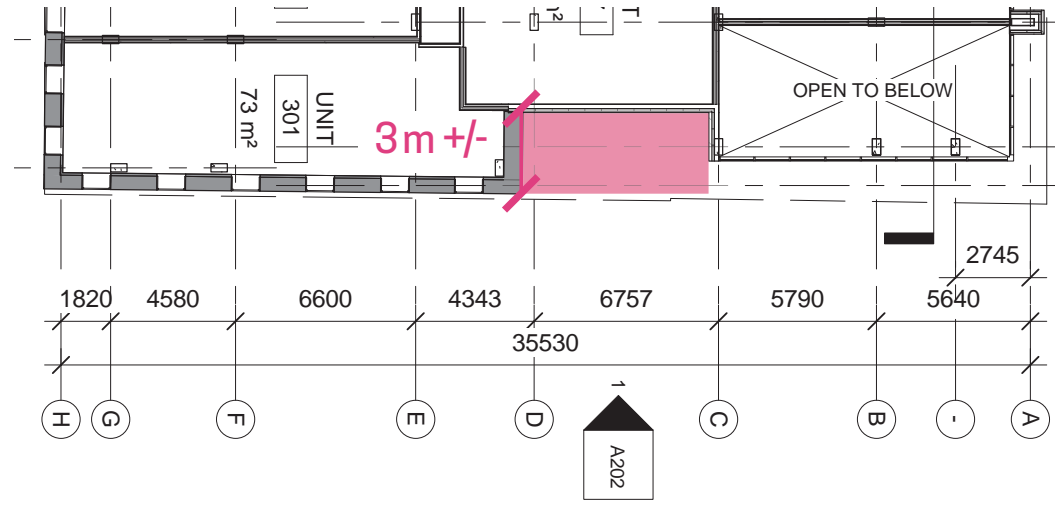

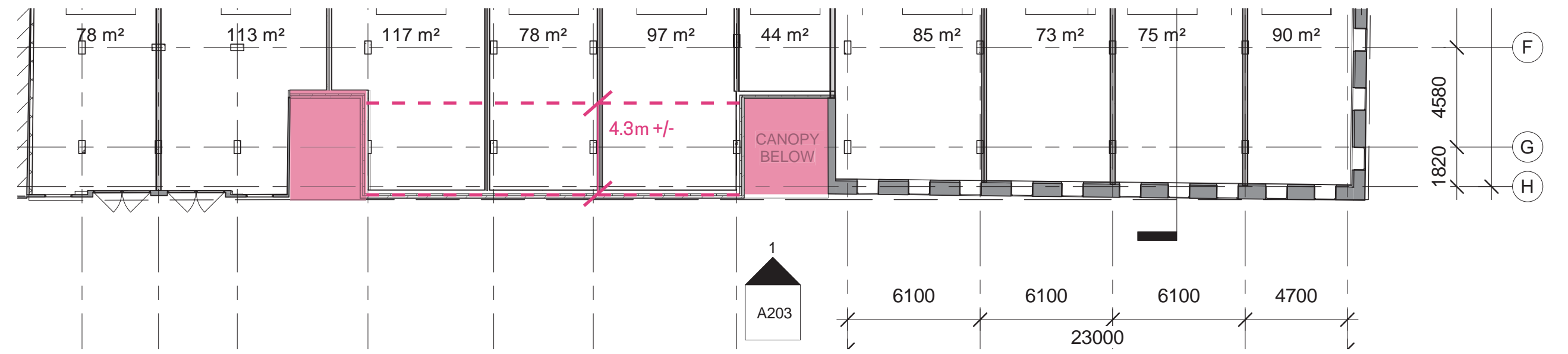

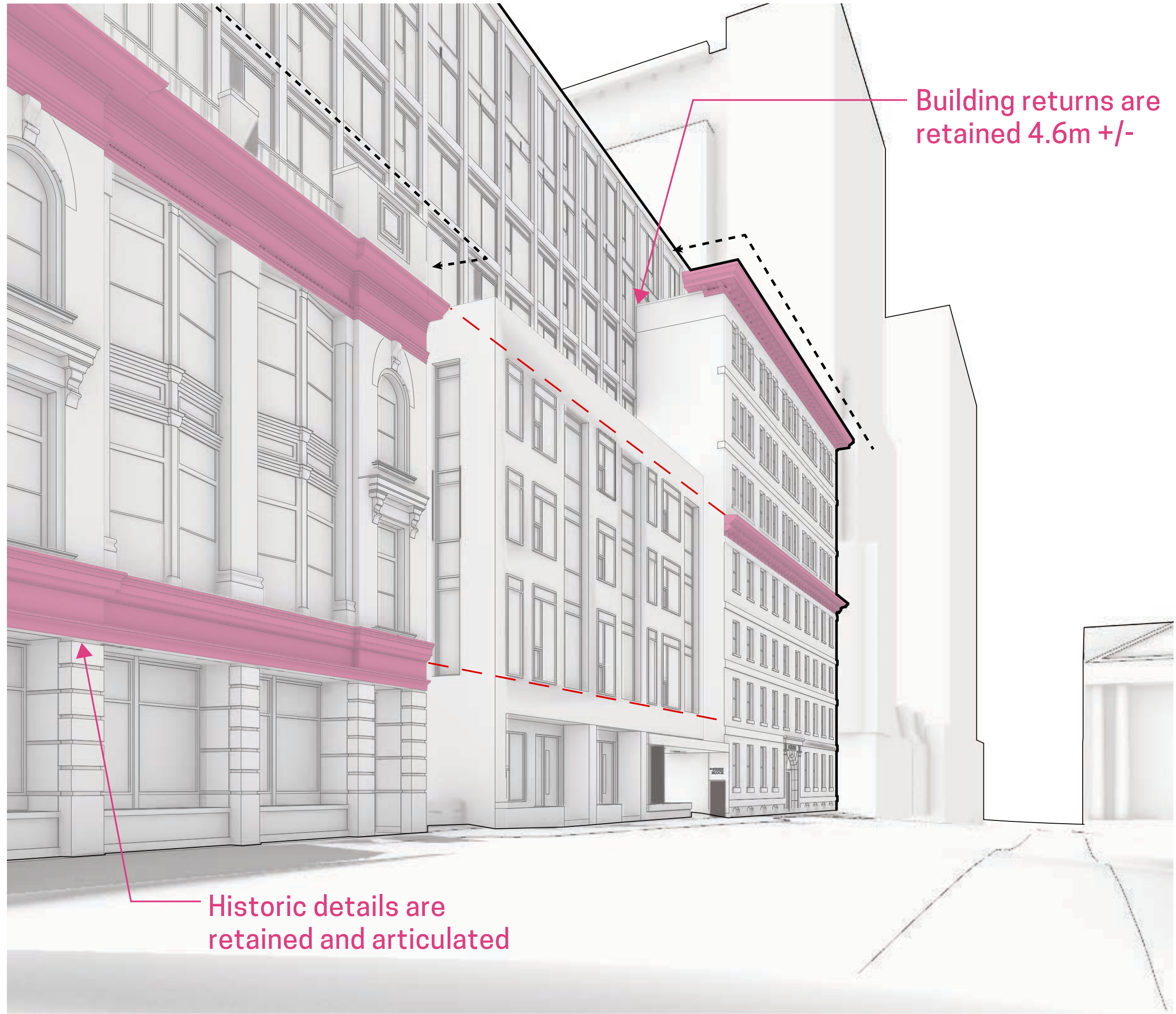



Variance Three: Building Height

The variance request is based on the following two rationales;

- i. Consistency with Downtown Halifax Schedule S-1 Design Manual
- ii. Built Heritage / Urban Character



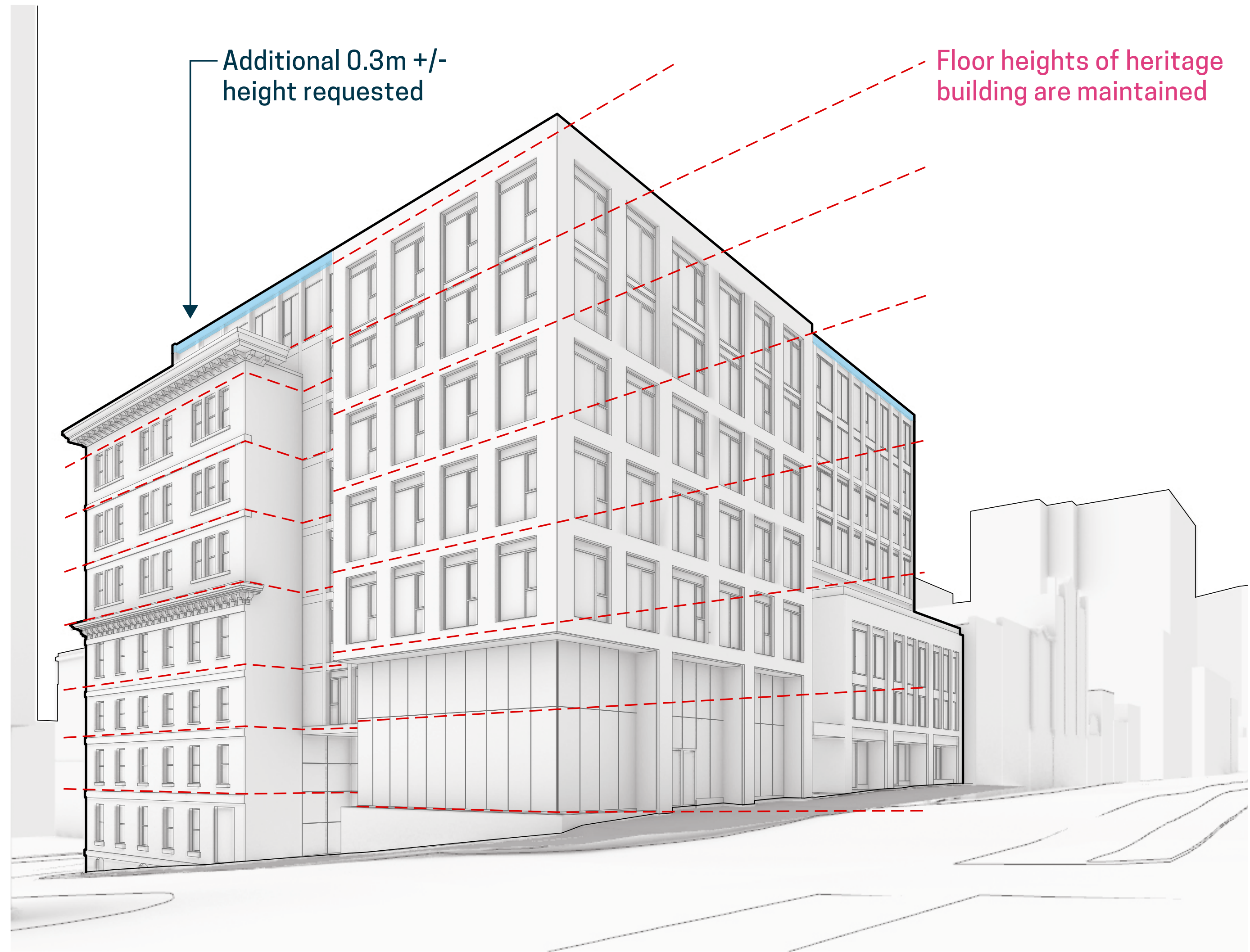

Additional 0.3m +/-
height requested

Floor heights of heritage
building are maintained





Variance Four: Land Use at Grade Floor to floor height

The variance request is based on the following two rationales;

- i. Consistency with Downtown Halifax Schedule S-1 Design Manual
- ii. Built Heritage / Urban Character



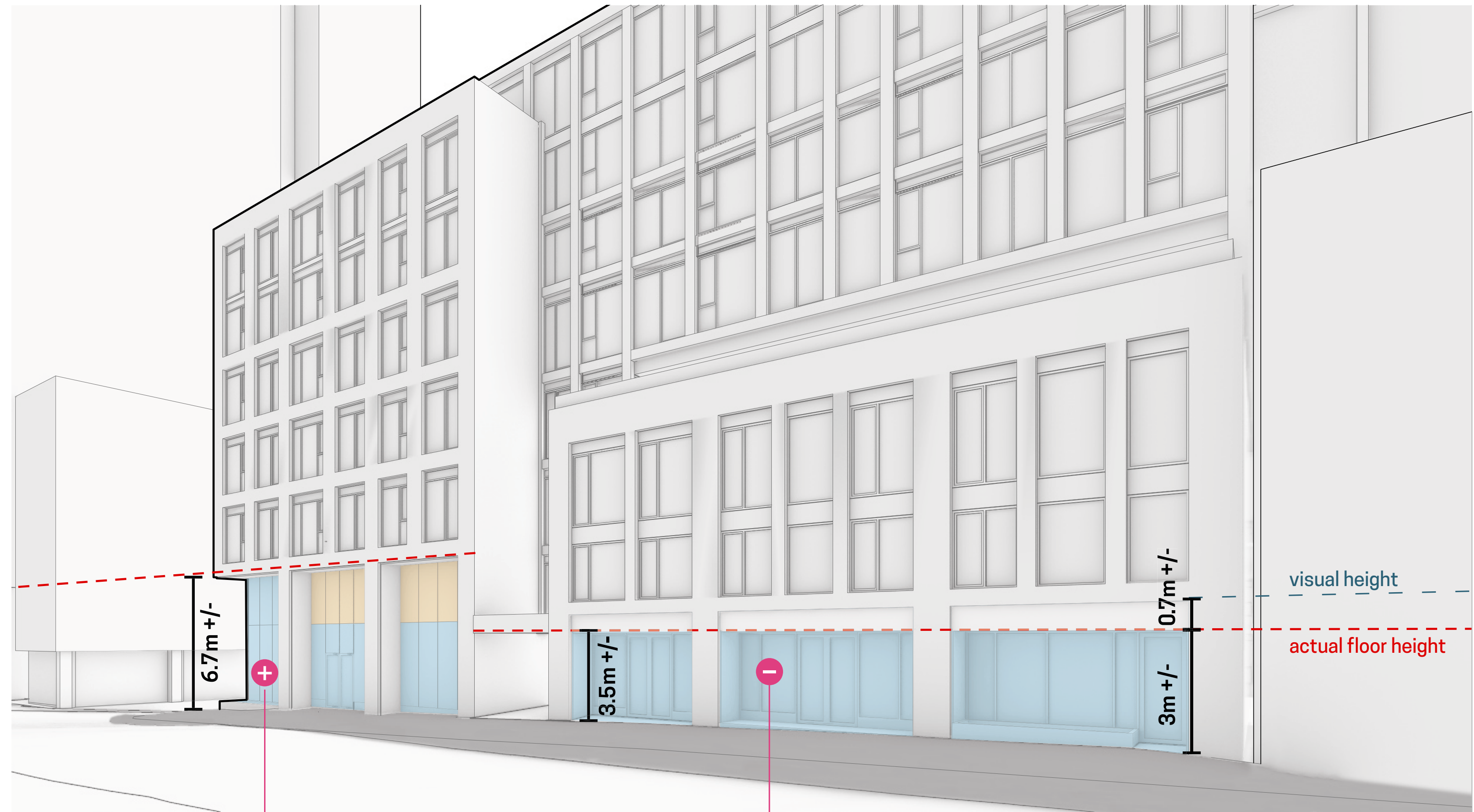

More than required,
double-height retail

Less than required,
openings mimic height requirement

residential
commercial



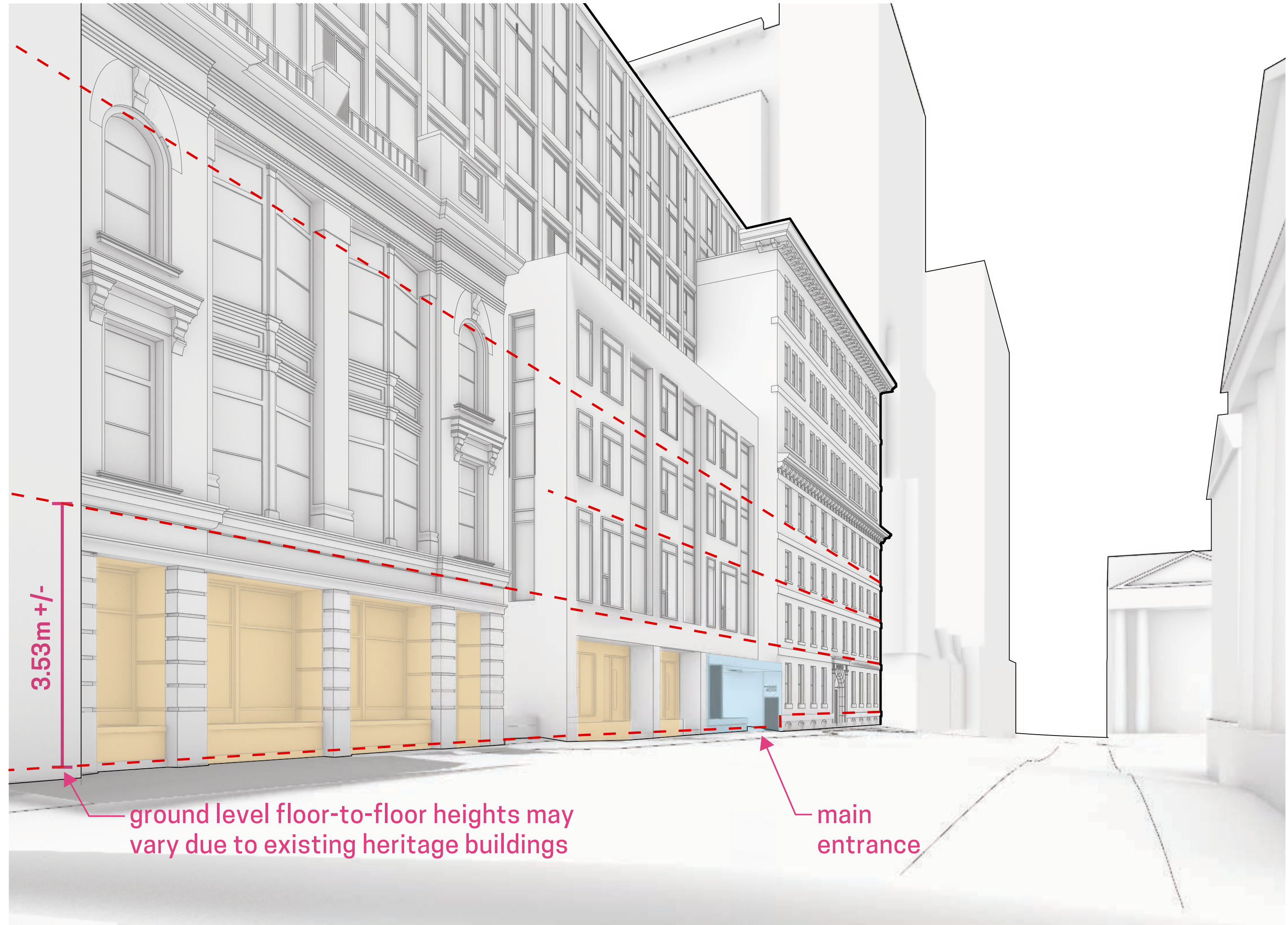

private
public



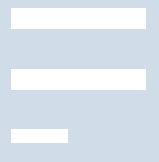

04 Moving Forward



From here our teams intend to activate streetscapes with interpretive content celebrating the rich history of this site. This will be reflected in interpretive panels, heritage distiction, and public art. Further to the public facing portions of the building the Brand, signage, wayfinding and interior design will also be integrated into a cohesive brand.



District

- newspaper as an institution
- site of the many newspapers:
*Acadian Recorder, Chronicle-Herald,
Mail-Star, Morning Herald, and Evening Mail*

P R E S S
B L O C K

George &
Granville

P R E S S | George &
B L O C K | Granville



THE SUITES AT PRESS BLOCK

A chronicle of press history in Nova Scotia.

Find out more →



THE SUITES AT PRESS BLOCK

A chronicle of press history in Nova Scotia.

Find out more →



Get your press pass to explore more

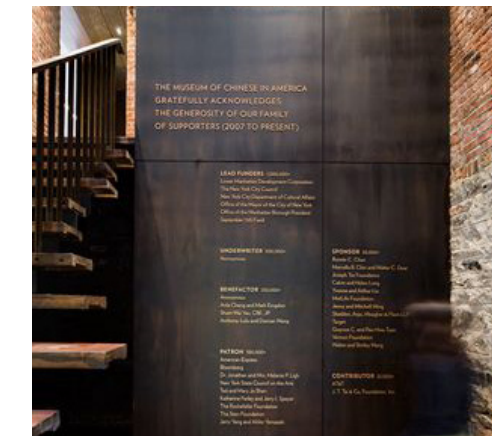

Be a part of journalism history



Live on Province House Square

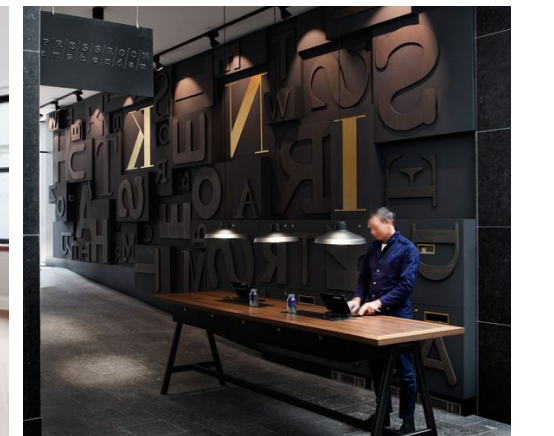

Amenities chronicle print history



"The floor-to-ceiling windows on all sides of the building, paired with 10-foot ceiling heights on every floor, created views of Halifax that would be difficult to attain in a new-construction high-rise."





fathom



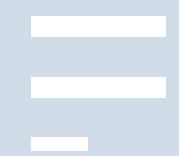
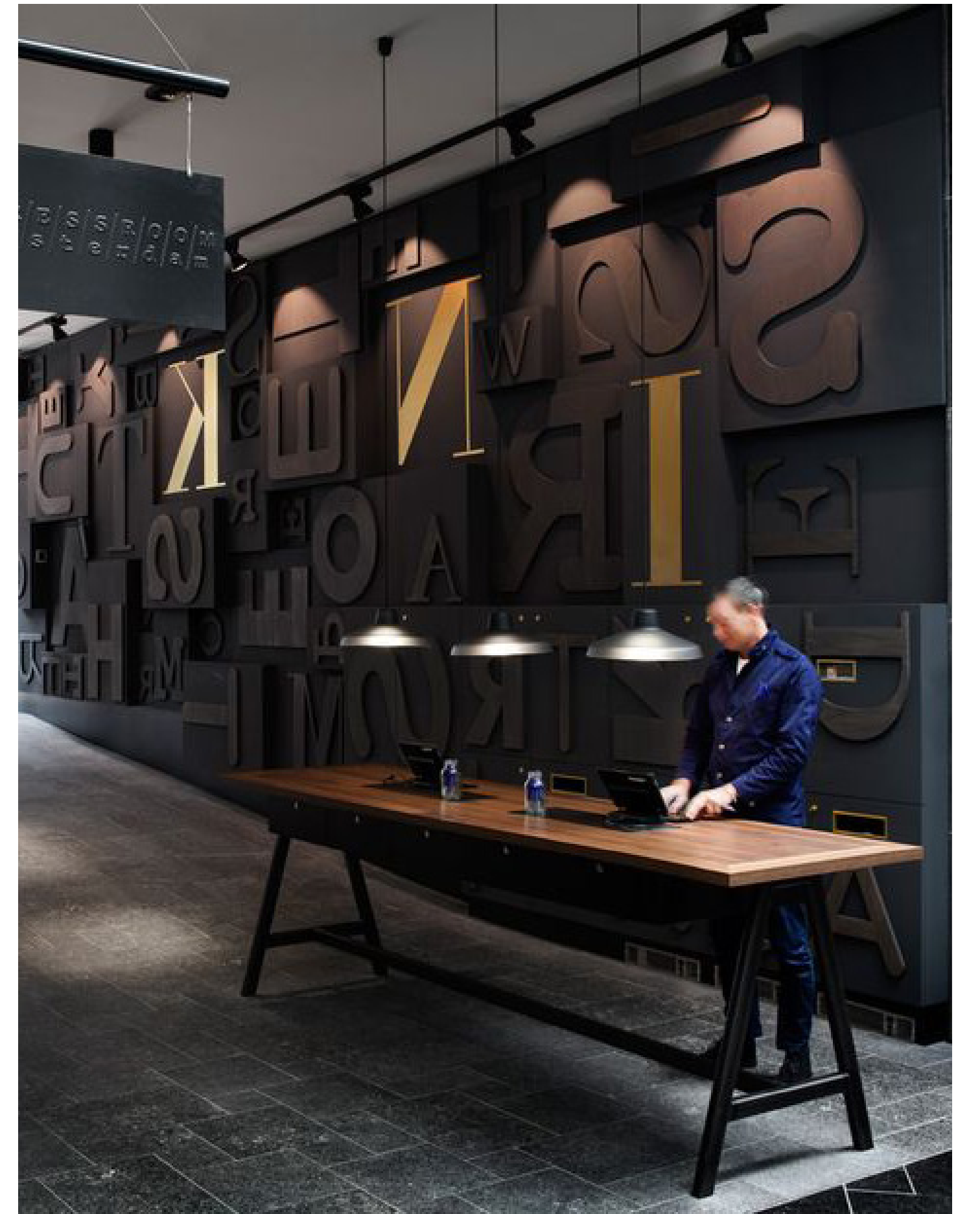

Overall look & feel



fathom





fathom

