

Sept 26, 2018

Aaron Murnaghan, MCIP, LPP
 PRINCIPAL PLANNER, HERITAGE
 HERITAGE OFFICER, PLANNING & DEVELOPMENT
 PO BOX 1749, HALIFAX NS B3J 3A5

Re: 2438 Gottingen Street - Shade and Wind Assessment (PID 00148791).

Dear Aaron;

The proposed 13-storey residential development project is located 2438 Gottingen Street with the lot penetrating through to Creighton Street (PID 00148791). The site sits just east of North Street, just across the street from the George Dixon Centre and next door to the 10-storey Sunrise Manor. The new proposed building will be located just behind Victoria Hall (See Fig.1).



The following assessment looks to interpret the likely wind impacts on surrounding properties and sidewalks as a result of the construction of the proposed development. Wind data, recorded at the local Shearwater Airport between 1953 and 2000, was assembled and analyzed using Windrose Pro 2.3 to understand the intensity, frequency, and direction of winds at the proposed site. The resulting diagram (Fig. 2) shows that the highest and most frequent annual wind speeds from the west and south and Fig 3. Shows this pattern in the context of the site.

Throughout the year, much of the stronger winds which could impact human thermal comfort come from the west (~13% of the time winds are greater than 5m/s), from the north and north-west (~12% of the time) and from the south and south-west (~9% of the time).

Wind changes in direction and intensity throughout the year. Strong winds (>20 mph) are usually associated with uncomfortable conditions for pedestrians. In Figure 4, the

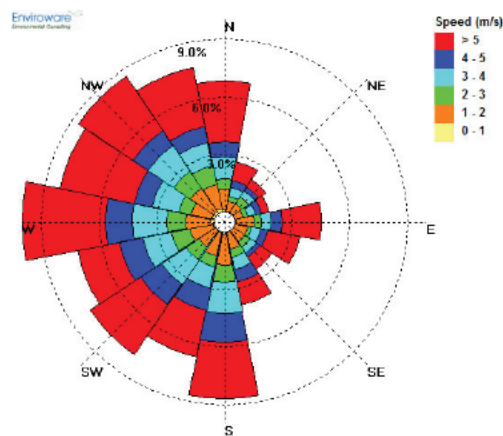

WindRose PRO
Figure 2. Wind Rose for Shearwater Airport. Annual wind diagram shows winds in the FROM direction.

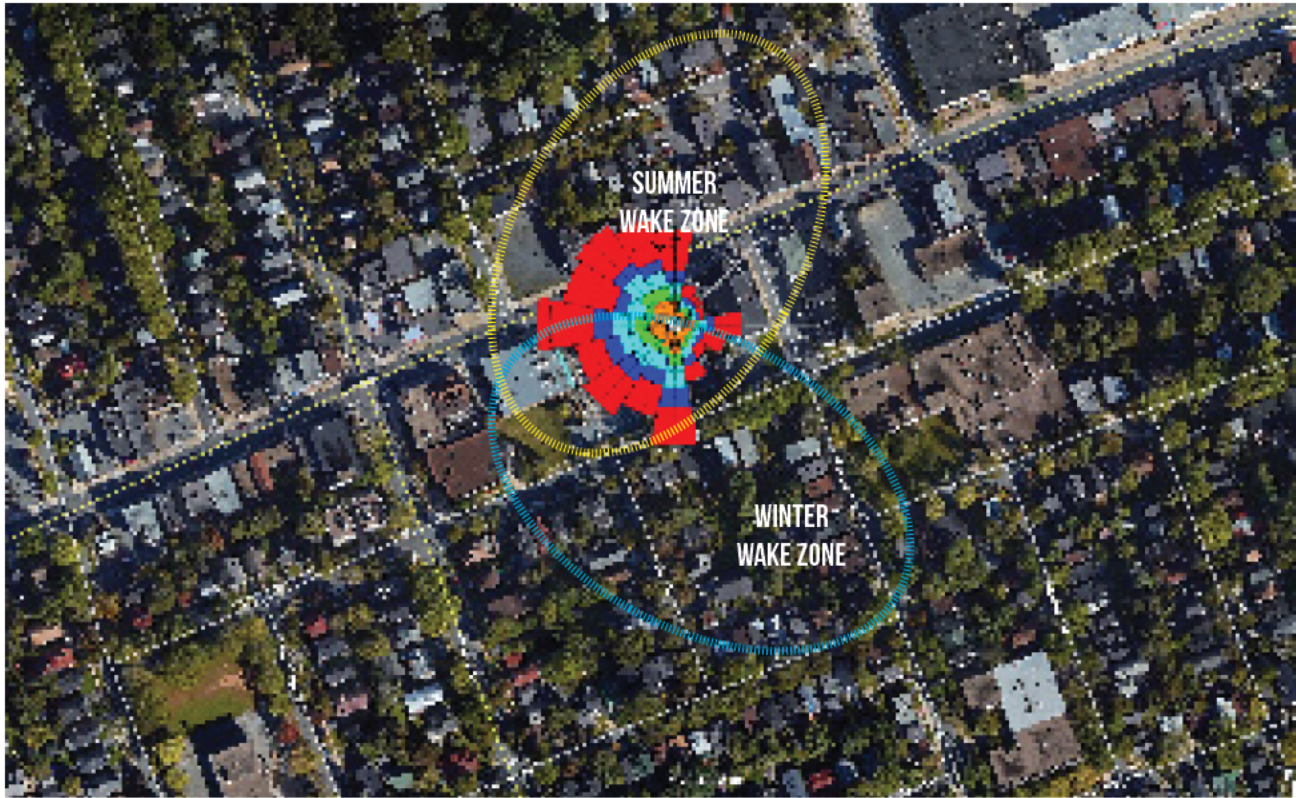

Figure 3. Wind Rose overlain on top of the proposed development site.

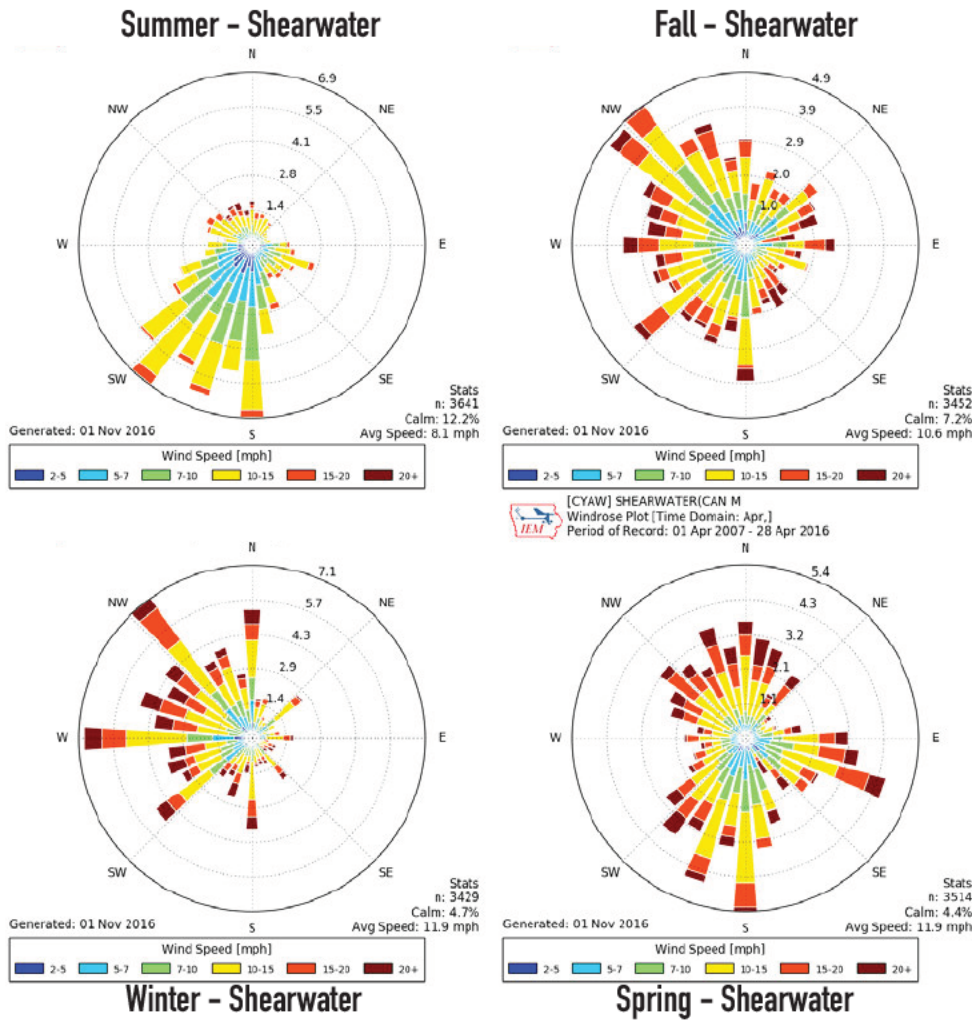
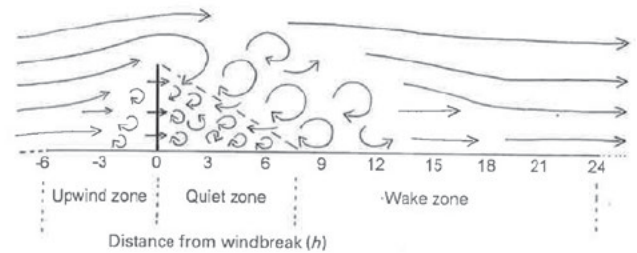

Figure 4. Seasonal Wind Direction for Shearwater Airport

strongest winds occur most frequently in the winter (from the west and north west) and spring (mostly from the west but occasionally from the north east). It is these winds that can cause uncomfortable thermal conditions in downtowns as a result of building design, though mature street trees can significantly reduce the impacts of strong winds around large buildings. The street trees on Gottingen Street are prolific across the street from this development but are sporadic on the south side of the street and on Creighton Street. The large trees that do exist provide good wind buffering capacity mostly in the summer but even into the winter months, the branches can reduce winds appreciably. Any street tree planting as part of this and future developments will improve the microclimate on the sidewalks in summer and winter conditions and every effort should be taken to preserve existing trees to mitigate wind conditions on the street.

During fall and winter months, strong winds blow predominantly from the north-west and west (See Fig 4). Throughout the spring strong winds can blow in many directions but predominantly from the north east (nor-easters), east and north directions. In the summer, winds predominantly originate from the south and south west, however, very little wind exceeds 20 mph.

The proposed development fills an empty parking lot on Creighton Street while preserving the Victoria Hall as it is today (mostly). Generally, most buildings in the neighbourhood range from 2-4 storeys, though just east of this site, the 10-storey Sunrise Manour extends for over 55m along Gottingen Street and it's south east orientation would definitely impact the thermal comfort on sidewalks on both Gottingen and Creighton Streets during the winter.



Zones with altered airflow caused by a windbreak. Vertical dimension is magnified for illustration. Vertical line indicates windbreak; h = height of windbreak. Large eddies = strong turbulence. Uninterrupted airflow in the open is to the left of the upwind zone, and to the right of the wake zone. Widths of zones are approximate. Based on several sources.

Figure 5. Windbreak Diagram

Urban Windbreak Impacts

As shown in Fig. 5 the new building will impact sidewalk conditions differently at different times of the year and at different sidewalk locations on both Gottingen or Creighton Streets. In the winter and fall, when it's coldest, both streets are aligned with the prevailing wind direction (north westerly), and in the summer, prevailing wind from the south and southwest.

Wake zones (downwind zones) for zero porosity structures (like a building) can extend 8-30 times the height of a structure. A typical 10-storey building can generate increased wind speeds between 250-900 metres on the downwind wake side (see Fig. 5). Beyond the wake zone, there is typically more turbulence and eddies as a result of more turbulent air. This can be characterized as being slightly more gusty winds with quiet periods interspersed with gusts of wind. Directly behind the windbreak, the quiet zone can extend from up to 8x the building height ($40m \times 8 = 320m$) on the downwind side. In this quiet zone, wind speeds can actually be reduced and street trees can play a big part in the wind reduction. At the edges of the building, wind speeds can increase as wind flows around the structure and accelerates. This can be even more pronounced when between two tall buildings creating a wind funnel effect.

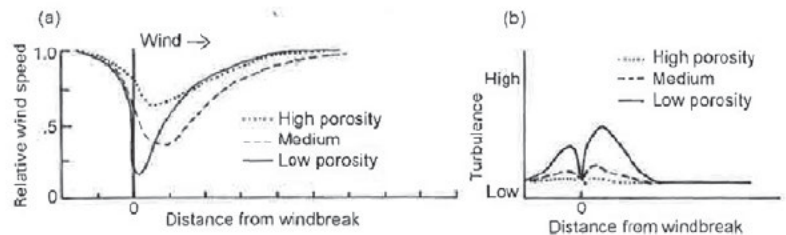

Effect of windbreak porosity on streamline and turbulent airflows. (a) Streamline airflow based on treebelts of different foliage densities; wind measurements at 1.4 m height. From Heisler & DeWalle (1988) with permission of Elsevier Science Publishers. (b) Generalized expected turbulence pattern based on Robinette (1972), Rosenberg et al. (1983), Heisler & DeWalle (1988), McNaughton (1988).

Figure 6. Porosity Diagram

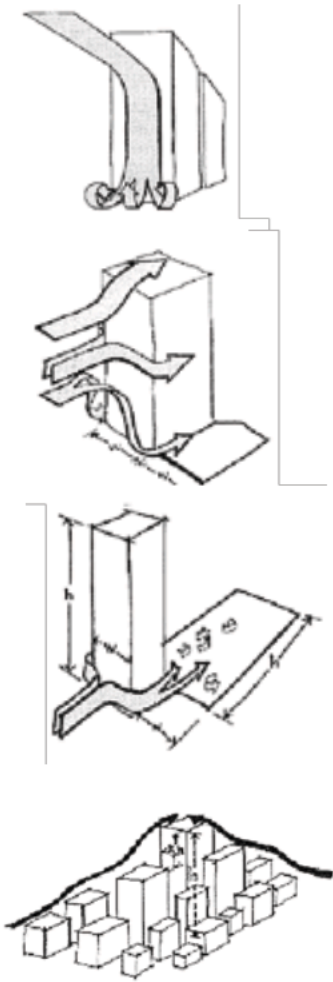

Wind Impacts from tall Buildings

There will be a number of impacts from the new building including:

1. **Downwash:** Wind speed increases with height so when a tower is exposed to wind, the pressure differential between the top and the bottom of tower forces the high pressure at the top down the windward face dramatically increasing pedestrian wind speeds. The taller the exposed face is, the higher the wind speed will be at the base. The stepback at the 3rd storey of the Creighton side of the new building will receive the bulk of this downwash while on Gottingen Street side, the stepback the existing Victoria Hall will buffer much of this downwash from the sidewalk on Gottingen. As a reference, a 30-storey building can cause up to 100% increase in wind speeds at the base unless downwash is mitigated by a podium.
2. **The corner effect:** at the windward (upwind) corners of buildings there can be unexpected increases in wind speeds as wind forces around the windward corners from high pressure on the windward face to low pressure on the lee side. Some of the ways to decrease this impact is to create pyramidal steps which increases the surface area of the edges. This has been designed into the proposed Building.
3. **The Wake Effect:** Wake is generally caused by both the downwash and corner effect. The greatest impact area occurs within an area of direct proportion to the tower height and width on the downwind side of the wind. Impacts are minimized by creating a stepback base on the building.
4. **Building Groups:** The effects that occur individually around buildings cannot be applied directly to groups of buildings. The cumulative effect of many clustered tall buildings, like in this situation, can create a wide range of different wind scenarios that must be modelled as a group to understand the cumulative impacts.

Pedestrian Comfort:

Pedestrian comfort and safety is an important factor to consider in the design of a

building and an area's built form, especially in a windier coastal city such as Halifax. The design of a building will impact how wind interacts at the ground level, impacting the pedestrian experience. The Beaufort scale is an empirical measure that relates wind speed to observed conditions on land and sea. The attached Beaufort scale is a general summary of how wind affects people and different activities, and distinguishes at what points wind speeds can become uncomfortable or dangerous.

Beaufort Scale

2-5 mph	calm
5-7 mph	light breeze
7-10 mph	gentle breeze
10-15 mph	moderate breeze
15-20 mph	fresh breeze
+20 mph	strong breeze

A building can impact both the wind speed and the wind turbulence at the pedestrian level. Wind turbulence not only creates uncomfortable environments through the rising of dust and other particles, it also decreases the temperature on the site. A properly designed building can mitigate some of the negative impacts of wind on the street level.

Seasonal Wind Impacts

Looking at the seasonal wind impacts (Fig. 4), in the winter and fall, the prevailing direction for strong winds (in excess of 20 mph) come from the northwest, west and north wind directions are. Approximately 48% of all winds come from the northwest. Winter winds are also stronger than those in the summer, with around fifteen percent of all winds reaching speeds above 20 mph. Strong winds only occur about 5% of the time in the north to west quadrant winter and about 3.5% of the time from the south to west quadrant. Gottingen Street and Creighton Street is aligned to the prevailing wind direction from the north-west meaning that winter winds can be accelerated through these corridors in the winter creating windy and cold conditions. The tower setback from both streets will reduce the impact compared with the tower pulled right up to both streets. These setbacks could make it slightly windier on Sunrise Manour in the winter. In the winter, both Gottingen and Creighton will be windier and less comfortable when winds comes from the north-west; however, this only occurs less than 5% of the time.

In the fall wind directions are generally the same as winter but with less wind speeds than the winter. During the winter and fall the north-west wind speeds on both streets will be increased, but the cumulative impact a new tower with the existing Sunrise Manour impacts cannot be determined without more detailed modelling. The setback at the third storey will mitigate much of these impacts. This impact could be further lessened by planting wind tolerant trees on both streets.

During the summer, the prevailing winds come from the south and southwest quadrant, approximately 85% of the time. There are very little winds that exceed 20 mph in the summer so the new building will have very little impact during the summer months except on very windy days. The orientation of Gottingen and Creighton (perpendicular to prevailing summer winds) will tend to have lesser impacts on sidewalk conditions in the summer. There may be some windier conditions noticeable in the George Dixon Park across the street in the summer.

In the spring, strong winds come from many directions with some of the most frequent coming from the north, northeast and even the easterly directions. During the spring this wind direction will have some impact when the winds come from the northeast. "Nor-easters" will create particularly windier conditions on Creighton Street and further to the south-west. Winds from these directions at high wind speeds only occur about 6% of the time. Still, the spring conditions will be the most pronounced of all the seasons as a result of the new building and about 5-6% of the time it will be windier and colder than it is today in and around Creighton Street.

COMFA Model (Brown and Gillespie, 1995)

Dr. Robert Brown of the University of Guelph developed the COMFA model to model human thermal comfort as a result of a number of variables including wind speed. Human thermal comfort is more pronounced during low-activity situations like sitting than during high-activity situations like running. The model is explained in the paper by Brown and LeBlanc (2003). Mr. LeBlanc was also the co-author with Dr. Brown in the 2008 ed. "Landscape Architectural Graphic Standards", Microclimate chapter. This model is the basis for the theoretical assessment of human thermal comfort changes as a result of the building explained below.

Wind Comfort Assessment

Changes in wind speed as a result of buildings vary depending on wind direction and building morphology. On both streets, 'streamlines' can occur where the wind is accelerated through the openings between Sunrise Manour and the new tower when the wind is oriented from the south-west. This orientation occurs in summertime but winds are generally much lower in the summer as well. When it does occur, it will be windier than today in George Dixon Park but the large trees in the park will deaden much of the strealine winds between the towers. It will also be windier on the back side of Victoria Hall as a result. The new building could result in increased uncomfortable conditions 3-4% of the time in the winter, 5-6% of the time in the spring and only 2-3% of the time in the summer. These reduced thermal comfort conditions are one of the trade-offs for intensification and increased density in the urban core and in the areas demarcated in the CentrePlan for growth.

Shade Study

The shade simulations were run at summer solstice (June 21), Equinox (Sept 21 and March 21), and winter solstice (Dec 21). During the summer solstice, there are about 1-2 extra hours of shade late in the afternoon on a portion of Gottingen Street and 1-2 hours of extra shade on Creighton Street early in the morning before 9am. Sunrise Manour is already shading both of these streets so the cumulative impact of the new tower will only have a small impact. During the equinox, the Gottingen sidewalk will have a small portion of sidewalk in shade for an extra 1-1.5 hours in the late afternoon (after 4) and 1-2 hours extra for a small portion of Creighton and Charles Street in the early morning before 10am. During the winter solstice, there will be very little impact on Creighton Street, but Gottingen Street in the vicinity of George Dixon will be in shade for an extra 4-5 hours in the deep of winter.

Summary

This new proposed 13-storey building will increase pedestrian discomfort in portions of Gottingen Street and Creighton Street at different times of the year. The winter will increase winds and shade in front of Victoria Hall creating more colder conditions for people on the street. The impacts on Creighton Street will be less pronounced but it will be windier and less comfortable to the south east of the new development when winds come from the north-west direction. The existing street trees on Gottingen Street will be important in mitigating wind impacts as a result of development and every effort should be made to preserve them during and after construction. Any new street trees on either street would help mitigate the impacts of taller buildings on the sidewalk conditions and HRM should make every effort to intensify the public urban forest program on the new planned density corridors of the Centre Plan. The design of the building with a 3 storey podium will significantly improve the impacts of the building on human thermal comfort on the street and surrounding neighborhoods.

If you have any questions, please contact me at your convenience.

Sincerely,



Robert LeBlanc, President
Ekistics Plan + Design

Gottingen Street Development

Shade Study for June 21

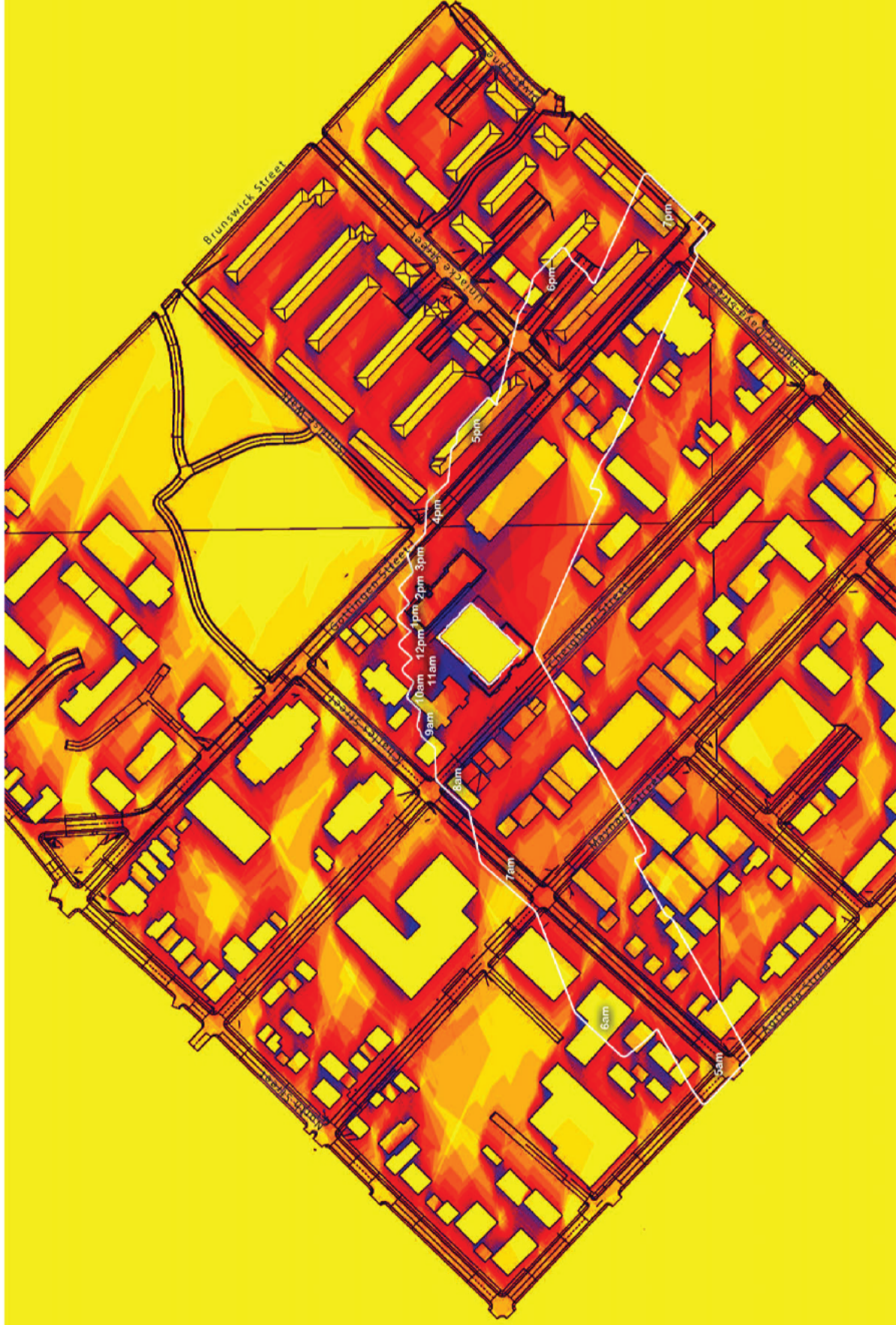

hours of shade

Gottingen Street Development

Shade Study for March & September 21

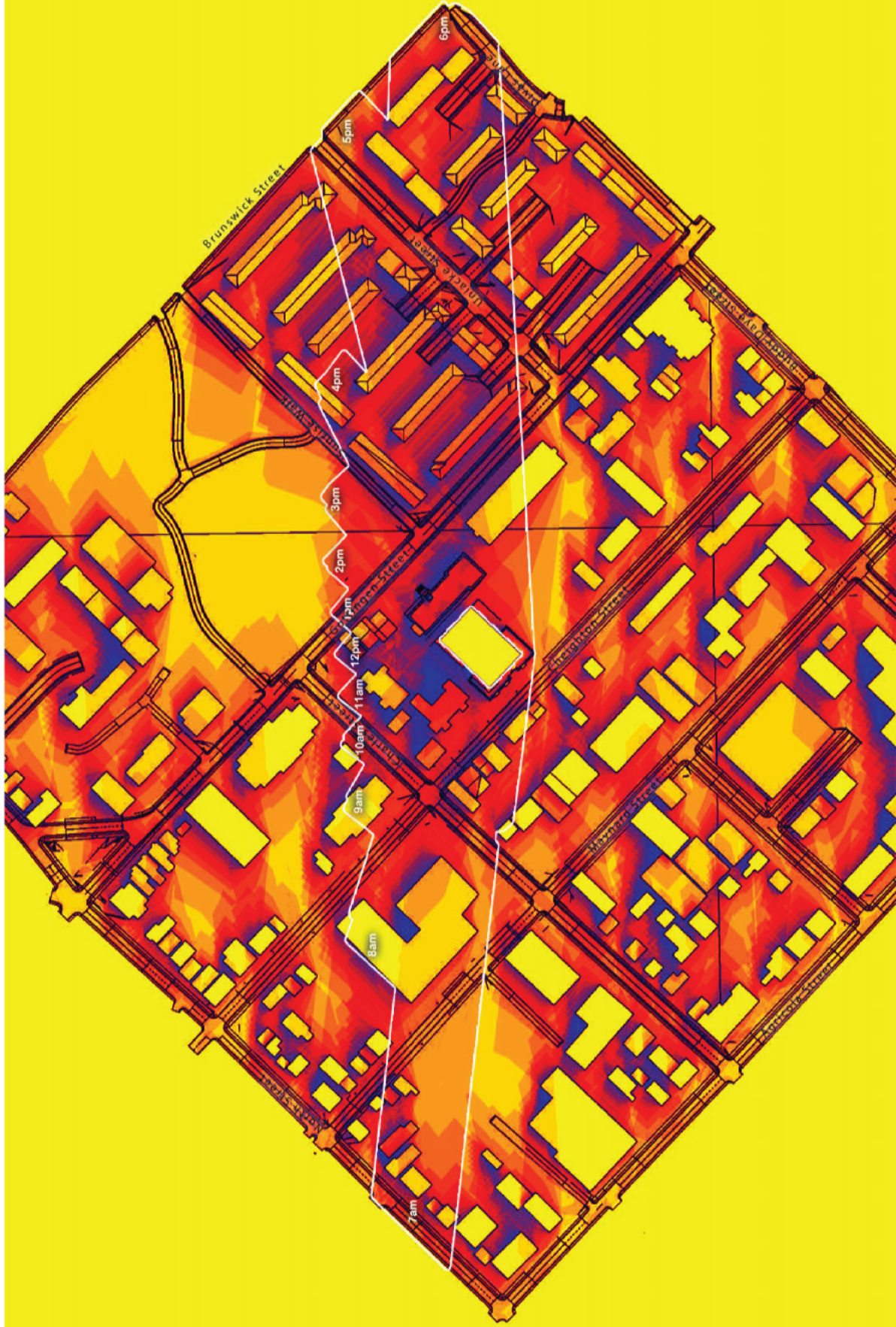

hours of shade

Gottingen Street Development

Shade Study for December 21

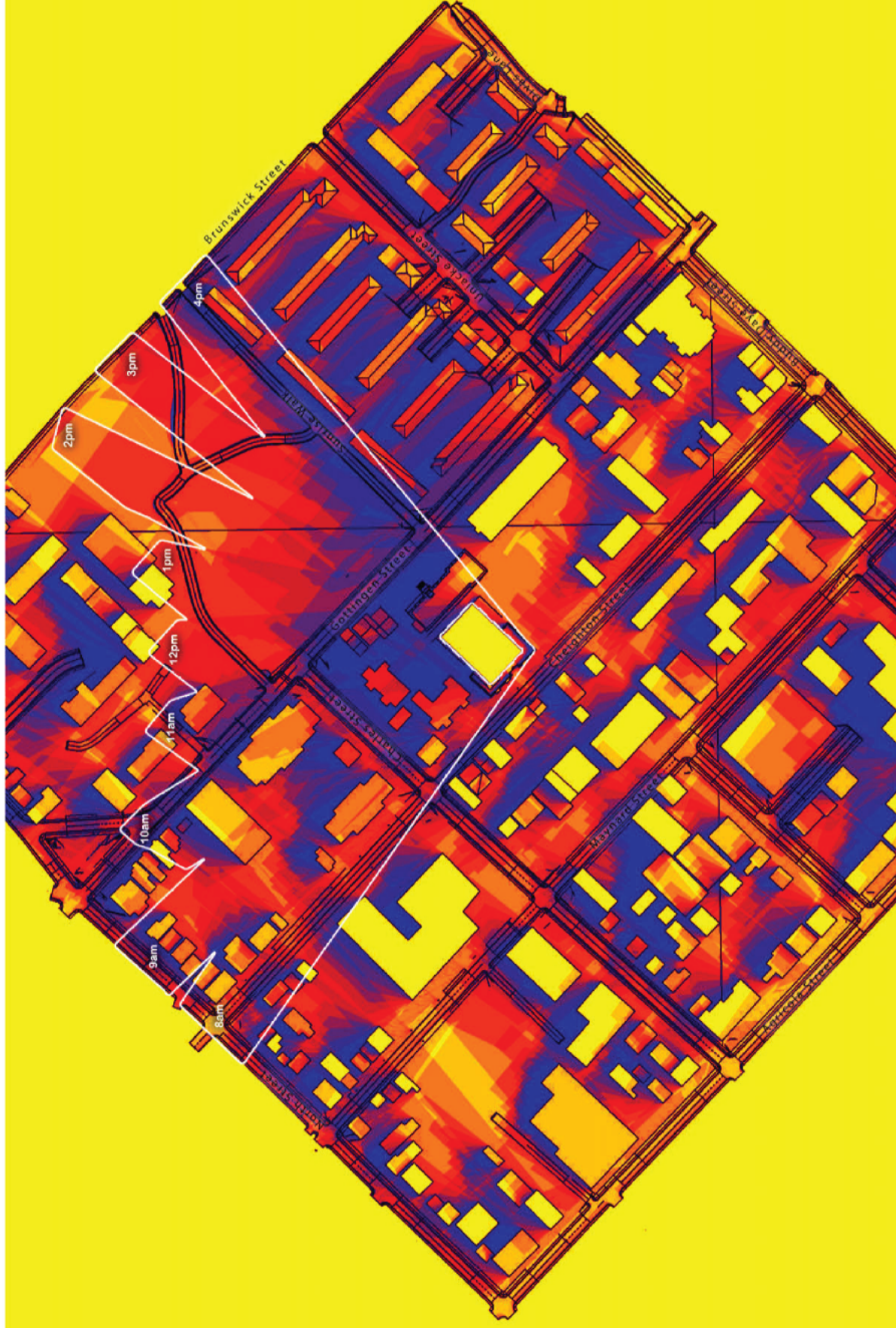

0 1 2 3 4 5 6 7 8 9 hours of shade